

EDWARD T. DEPP  
502-540-2348  
[edepp@dinslaw.com](mailto:edepp@dinslaw.com)

February 11, 2004

Thomas M. Dorman  
Executive Director  
Public Service Commission  
211 Sower Blvd.  
P. O. Box 615  
Frankfort, KY 40601

***Re: Joint Petition for Arbitration of NewSouth Communications Corp., NuVox Communications, Inc., KMC Telecom V, Inc., KMC Telecom III LLC, and Xspedius Communications, LLC on Behalf of Its Operating Subsidiaries, Xspedius Management Co. Switched Services, LLC, Xspedius Management Co. of Lexington, LLC, and Xspedius Management Co. of Louisville, LLC***

Dear Mr. Dorman:

I have enclosed for filing with the Commission an original and ten (10) copies of the Joint Petition for Arbitration for the above entities against BellSouth Telecommunications, Inc.

Thank you. If you have any questions, please call us.

Sincerely,

DINSMORE & SHOHL LLP

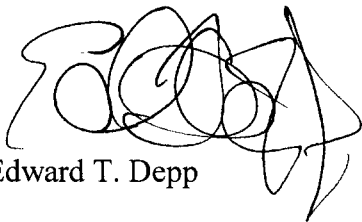
  
Edward T. Depp

ETD/bmt  
Enclosures

cc/Eric Soriano

88387v1  
28791-1

**BEFORE THE  
KENTUCKY PUBLIC SERVICE COMMISSION**

**In the Matter of** )  
 )  
**Joint Petition for Arbitration of** )  
 )  
**NEWSOUTH COMMUNICATIONS CORP.,** )  
**NUVOX COMMUNICATIONS, INC.** )  
**KMC TELECOM V, INC., KMC TELECOM** )  
**III LLC, and XSPEDIUS COMMUNICATIONS,** )  
**LLC on Behalf of its Operating** )  
**Subsidiaries XSPEDIUS MANAGEMENT CO.** )  
**SWITCHED SERVICES, LLC, XSPEDIUS** )  
**MANAGEMENT CO. OF LEXINGTON, LLC,** )  
**and XSPEDIUS MANAGEMENT CO. OF** )  
**LOUISVILLE, LLC** )  
 )  
**Of an Interconnection Agreement with** )  
**BellSouth Telecommunications, Inc.** )  
**Pursuant to Section 252(b) of the** )  
**Communications Act of 1934, as** )  
**Amended** )

---

**JOINT PETITION FOR ARBITRATION**

---

**NewSouth Communications Corp.** (“NewSouth”); **NuVox Communications, Inc.** (“NuVox”); **KMC Telecom V, Inc.** (“KMC V”) and **KMC Telecom III LLC** (“KMC III”) (collectively, “KMC”); and **Xspedius Communications, LLC** on behalf of its operating subsidiaries **Xspedius Management Co. Switched Services, LLC** (“Xspedius Switched”), **Xspedius Management Co. of Lexington, LLC** (“Xspedius Lexington”), and **Xspedius Management Co. of Louisville** (“Xspedius Louisville”) (collectively “Xspedius”) (collectively, the “Joint Petitioners” or “CLECs”), by their attorneys and pursuant to Section 252(b) of the

Communications Act of 1934, as amended (the “Communications Act”); 807 KAR 5:001, Rules of Procedure; and other applicable statutes, rules and regulations, and decisions, and hereby file with the Kentucky Public Service Commission (the “Commission”) this Joint Petition for Arbitration (the “Joint Petition”) seeking resolution of certain issues arising between the Joint Petitioners and BellSouth Telecommunications, Inc. (“BellSouth”) in the negotiation of an interconnection agreement. In support of this Joint Petition, the Joint Petitioners state as follows:

**I. DESIGNATED CONTACTS**

1. All communications, filings, and submissions in this proceeding, including but not limited to, correspondence, notices, inquiries, and orders, should be served upon the following designated contacts for the Joint Petitioners:

**For NewSouth:**

Jake E. Jennings, Senior Vice President,  
Regulatory Affairs and Carrier Relations  
Two North Main Street  
Greenville, South Carolina 29601  
Tel. (864) 672-5877  
Fax (864) 672-5105

**For NuVox:**

Bo Russell, Regional Vice President – Regulatory and Legal Affairs SE  
301 North Main Street, Suite 5000  
Greenville, South Carolina 29601  
Tel. (864) 331-7323  
Fax (864) 313-1236

**For KMC:**

Marva Brown Johnson, Senior Regulatory Policy Advisor  
1755 North Brown Road  
Lawrenceville, Georgia 30043  
Tel. (678) 985-6220  
Fax (678) 985-6213

**For Xspedius:**

James C. Falvey, Senior Vice President – Regulatory Affairs  
7125 Columbia Gateway Drive, Suite 200  
Columbia, Maryland 21046  
Tel. (301) 361-4298  
Fax (301) 361-7654

with a copy to:

John J. Heitmann  
Enrico C. Soriano  
Heather T. Hendrickson  
KELLEY DRYE & WARREN LLP  
1200 Nineteenth Street, N.W., Suite 500  
Washington, D.C. 20036  
Tel. (202) 955-9600  
Fax (202) 955-9792  
[jheitmann@kelledrye.com](mailto:jheitmann@kelledrye.com)  
[esoriano@kelleydrye.com](mailto:esoriano@kelleydrye.com)  
[hhendrickson@kelleydrye.com](mailto:hhendrickson@kelleydrye.com)

and to:

John E. Selent  
DINSMORE & SHOHL LLP  
1400 PNC Plaza  
500 West Jefferson St.  
Louisville, KY 40202  
Tel. 502-540-2300  
Fax 502-585-2207  
[john.selent@dinslaw.com](mailto:john.selent@dinslaw.com)

2. BellSouth's attorneys and lead negotiators are:

J. Philip Carver  
Rhona Reynolds  
Annamarie LeMoine  
BELLSOUTH TELECOMMUNICATIONS, INC.  
1155 Peachtree Street NE  
Atlanta, Georgia 30309-3610  
Tel. (404) 249-2000

James Tamplin  
Julie O’Kelley  
Shelley Decker  
BELL SOUTH TELECOMMUNICATIONS, INC.  
1155 Peachtree Street NE  
Atlanta, Georgia 30309-3610  
Tel. (404) 249-2000

## II. STATEMENT OF FACTS

3. BellSouth is an incumbent local exchange carrier (“ILEC”), as defined by the Communications Act. *See* 47 U.S.C. § 251(h). To the best of the Joint Petitioners’ knowledge, BellSouth’s executive offices are located at 1155 Peachtree Street NE, Atlanta, Georgia 30309-3610. Within its operating territory, including Kentucky, BellSouth has, at relevant times, been a dominant provider of telephone exchange service.

4. Pursuant to the Communications Act, BellSouth is required to provide to requesting telecommunications carriers, through negotiation or otherwise, interconnection, access to unbundled network elements (“UNEs”), collocation, number portability, dialing parity, access to rights-of-way, reciprocal compensation, and resale, among other things. *See* 47 U.S.C. §§ 251(b)-(c). The terms and conditions of interconnection must comply with the provisions of sections 251 and 252 of the Communications Act. *See* 47 U.S.C. § 251(c). Section 252(d) of the Communications Act governs the pricing of UNEs, interconnection, reciprocal compensation, and resale services.

5. Joint Petitioner NewSouth is a competitive local exchange carrier formed under the laws of the State of Delaware, and having its principal place of business at Two North Main Street, Greenville, South Carolina 29601. NewSouth currently provides or is authorized to provide voice and data, local, long distance, and bundled telecommunications services in several states. In Kentucky, NewSouth is authorized by the Commission to provide local exchange and

interexchange services pursuant to Computer ID No. 5013200, issued on February 28, 1999.

6. Joint Petitioner NuVox is a competitive local exchange carrier formed under the laws of the State of South Carolina, and having its principal place of business at 301 N. Main Street, Suite 5000, Greenville, SC. NuVox currently provides or is authorized to provide local and long distance telecommunications services in several states. In Kentucky, NuVox is authorized by the Commission to provide telecommunications services pursuant to Tariff Filing No. T62-0497, effective April 10, 2001.

7. Joint Petitioner KMC is a competitive local exchange carrier formed under the laws of the State of Delaware, and having its principal place of business at 1755 North Brown Road, Lawrenceville, GA 30043. KMC currently provides or is authorized to provide telecommunications services in several states. In Kentucky, KMC V is authorized by the Commission to provide local exchange and long distance services on July 28, 2000.

8. Joint Petitioners Xspedius Switched, Xspedius Lexington, and Xspedius Louisville are limited liability companies formed under the laws of the State of Delaware, and having their principal place of business at 5555 Winghaven Boulevard, Suite 300, O'Fallon, Missouri 63366. In Kentucky, Xspedius Switched is authorized to provide switched telecommunications services, pursuant to Docket No. T-63-0785. Likewise, Xspedius Lexington and Xspedius Louisville are authorized as Competitive Access Providers, pursuant to Docket Nos. T-63-0787 and T-63-0786, respectively.

9. Joint Petitioners previously entered into interconnection agreements with BellSouth which were subsequently approved by the Commission. These interconnection agreements have expired, although the Joint Petitioners and BellSouth have agreed to continue to operate pursuant to the rates, terms, and conditions of their respective interconnection

agreements until such time as their replacement interconnection agreements are approved by the Commission.

**10.** Prior to the expiration of their interconnection agreements, BellSouth provided to the Joint Petitioners requests for negotiation of a new interconnection agreement. For the purpose of establishing the statutory timeframes set forth in Section 252 of the Communications Act, the Joint Petitioners and BellSouth have agreed that negotiations began on September 6, 2003. Accordingly, the window for filing a formal request for arbitration under the Communications Act opened on January 17, 2004, and closes on February 11, 2004.

**11.** Subsequent to the Joint Petitioners' receipt of BellSouth's requests for negotiation, Joint Petitioners and BellSouth held numerous meetings, both in person and by telephone, to discuss the rates, terms, and conditions pursuant to which BellSouth would provide to Joint Petitioners interconnection, access to UNEs, collocation, and resale, among other things. As a result of these good faith negotiations, Joint Petitioners and BellSouth have reached agreement on many of the issues raised during the statutorily prescribed interconnection negotiation period. However, Joint Petitioners and BellSouth have not reached agreement on a number of other issues. Consequently, Joint Petitioners are filing this Joint Petition, pursuant to Section 252 of the Communications Act and other applicable law, to seek arbitration of the issues that remain unresolved.

**12.** The Joint Petitioners are filing a joint petition for arbitration as opposed to several individual petitions for arbitration because, in order to maximize limited resources, efficiency, and bargaining power, they have been negotiating with BellSouth as a group. Moreover, the vast majority of the issues that remain in dispute are common to each of the Joint Petitioners. Specifically, all the issues related to all the attachments, other than Attachment 3,

are shared in common by the Joint Petitioners. Of the 107 issues set for arbitration, only ten issues are not common among all parties and only six of those ten issues are single-party issues. No CLEC party takes a position adverse to the position taken by the other CLEC parties and, to the fullest extent possible, CLECs anticipate the use of a “team” witness approach. Because there are common questions of law and fact in this arbitration proceeding, separate filings and hearings would result in unwarranted expense to the parties and the Commission, as well as unnecessary delay, particularly considering the statutory deadline within which the Commission is charged with concluding this arbitration proceeding. Accordingly, the Joint Petitioners submit that, for reasons of administrative efficiency and economy, a joint petition and hearing is appropriate. Alternatively, should the Commission decide that separate petitions for arbitration should be filed by each of the Joint Petitioners, the Joint Petitioners respectfully request that the Commission (a) grant them adequate time to prepare and submit their individual petitions for arbitration, and (b) toll the statutory deadlines imposed by Section 252(b)(1) of the Communications Act for good cause.

### **III. JURISDICTION AND APPLICABLE LAW**

**13.** Under the Communications Act, parties to an interconnection negotiation have the right to petition the relevant state commission for arbitration of any open issue whenever negotiations between them fail to yield an agreement. *See* 47 U.S.C. § 252(b). Either party may seek arbitration during the period between the 135<sup>th</sup> day and the 160<sup>th</sup> day, inclusive, after the date the ILEC received the request for negotiation. *Id.*

**14.** Because the Joint Petitioners and BellSouth have agreed that, for the purpose of their arbitration, negotiations began on September 6, 2003, the statutory window for filing a formal request for arbitration opened on January 17, 2004, and will close on February 11,



2004. Accordingly, this Joint Petition is timely filed. Section 252(b)(4)(C) of the Communications Act requires that the Commission conclude the resolution of any unresolved issues within nine (9) months after the request for interconnection negotiation was initiated. 47 U.S.C. § 252(b)(4)(C). Consequently, unless the Joint Petitioners waive the statutory deadline, the Commission must conclude this arbitration no later than June 6, 2004.

**15.** The Federal Communications Commission (the “FCC”) established the appropriate standard for arbitration under Sections 251 and 252 of the Act in *Implementation of the Local Competition Provisions of the Telecommunications Act of 1996*, CC Docket No. 96-98, First Report and Order (rel. Aug. 8, 1996) (*Local Competition Order*). Pursuant to the *Local Competition Order*, the Commission must do the following in an arbitration: (1) ensure resolution and conditions satisfying Section 251 of the Communications Act, including the regulations promulgated by the FCC; and (2) establish rates for interconnection and UNEs according to Section 252(d) of the Act.

**16.** The Commission must make an affirmative determination that the rates, terms, and conditions that it prescribes in this arbitration proceeding for interconnection are consistent with the requirements of Section 251(b)-(c) and Section 252(d) of the Communications Act. Notably, Section 252(c)(3) of the Communications Act, which requires that an implementation schedule be prescribed, is inapplicable because the Joint Petitioners and BellSouth already have implemented interconnection arrangements pursuant to their existing interconnection agreements.

**17.** Section 251(b) of the Communications Act, 47 U.S.C. § 251(b), states that each local exchange carrier has the following duties:

- (1) the duty not to prohibit, and not to impose unreasonable or discriminatory conditions or limitations on, the resale of its telecommunications service;
- (2) the duty to provide, to the extent technically feasible, number portability in accordance with requirements prescribed by the FCC;
- (3) the duty to provide dialing parity to competing providers of telephone exchange service and telephone toll service, and the duty to permit all such providers to have nondiscriminatory access to telephone numbers, operator services, directory assistance, and directory listing, with no unreasonable dialing delays;
- (4) the duty to afford access to the poles, ducts, conduits, and rights-of-way of such carrier to competing providers of telecommunications services on rates, terms, and conditions that are consistent with Section 224 of the Act; and
- (5) the duty to establish reciprocal compensation arrangements for the transport and termination of telecommunications.

**18.** Section 251(c) of the Communications Act states that each incumbent local exchange carrier, such as BellSouth, has the following additional duties:

- (1) the duty to negotiate in good faith;
- (2) the duty to provide, for the facilities and equipment of any requesting telecommunications carrier, interconnection with the local exchange carrier's network for the transmission and routing of telephone exchange service and exchange access at any technically feasible point within the carrier's network that is at least equal in quality to that provided by the local exchange carrier to itself, or to any subsidiary, affiliate, or any other party to which the carrier provides interconnection on rates, terms and conditions that are just, reasonable and nondiscriminatory;
- (3) the duty to provide, to any requesting telecommunications carrier, nondiscriminatory access to network elements on an unbundled basis at any technically feasible point on rates, terms and conditions that are just, reasonable and nondiscriminatory and in such a manner that allows requesting carriers to combine such elements in order to provide such telecommunications service;
- (4) the duty to offer for resale at wholesale rates any telecommunications service that the carrier provides at retail to subscribers who are not telecommunications carriers and not to

prohibit, and not to impose unreasonable or discriminatory conditions or limitations on the resale of such services;

- (5) the duty to provide reasonable public notice of changes in the information necessary for the transmission and routing of services using that local exchange carrier's facilities or networks, as well as of any other changes that would affect the interoperability of those facilities and networks; and
- (6) the duty to provide, on rates, terms and conditions that are just, reasonable and nondiscriminatory, for physical collocation of equipment necessary for interconnection or access to unbundled network elements at the premises of the local exchange carrier, except that virtual collocation may be provided if the local exchange carrier demonstrates to the State commission that physical collocation is not practical for technical reasons or because of space limitations.

19. Section 252(d) of the Communications Act sets forth the applicable pricing standards for interconnection and network element charges, as well as for collocation, transport, and termination of traffic. Section 252(d)(1) of the Communications Act states, in pertinent part, that “determinations by a State commission of the just and reasonable rate for the interconnection of facilities and equipment . . . and the just and reasonable rate for network elements . . . shall be (i) based on the cost (determined by reference to a rate-of-return or other rate-based proceeding) of providing the interconnection or network element (whichever is applicable); and (ii) nondiscriminatory; and [(iii)] may include a reasonable profit.” 47 U.S.C. § 252(d)(1). Section 252(d)(2) of the Communications Act further states, in pertinent part, that “a State commission shall not consider the terms and conditions for reciprocal compensation [for transport and termination] to be just and reasonable unless (i) such terms and conditions provide for the mutual and reciprocal recovery by each carrier of costs associated with the transport and termination on each carrier's network facilities of calls that originate on the network facilities of another carrier; and (ii) such terms and conditions determine such costs on the basis of a

reasonable approximation of the additional costs of terminating such calls.” 47 U.S.C. § 252(d)(2).

#### IV. ARBITRATION ISSUES AND POSITIONS OF THE PARTIES

20. The unresolved issues between the Joint Petitioners and BellSouth, and the parties’ respective positions as to each unresolved issue, are detailed below (*see also* CLEC-BellSouth Joint Issues Matrix, which is attached hereto and incorporated herein by reference as *Exhibit 1*).<sup>1</sup> Due to the imminent close of the window for filing a formal request for arbitration, the Joint Petitioners are compelled to seek arbitration of a number of issues which remain under discussion between BellSouth and the Joint Petitioners. The Joint Petitioners remain hopeful that some or many of these issues will be resolved prior to hearing, either through continued negotiations or Commission mediation. Finally, while the parties have attempted to exhaustively identify all the disputed issues, additional issues may arise while the parties continue their interconnection negotiations. Accordingly, the Joint Petitioners reserve the right to amend,

---

<sup>1</sup> Issues identified are common among CLECs in all cases other than with respect to “Interconnection (Attachment 3)”, where each CLEC, instead of using the same attachment (as is the case with all other attachments, as well as the General Terms and Conditions) is using a CLEC-specific customized version derived from a common template. Thus, while there is a single version of the General Terms and Conditions, and the 11 attachments other than Attachment 3, there is a version of Attachment 3 for each CLEC. There is a high degree of commonality among these individual Attachment 3s and the issues raised with respect thereto. For Attachment 3 issues, section numbers are accompanied by indications of which CLEC’s Attachment 3 the section belongs to. Identical text associated with the same issue is sometimes accorded a different section number (e.g., with respect to Issue 3-1, identical text is Section 3.3.4 in each CLEC’s Attachment 3, other than Xspedius’s, where it is Section 3.3.3). Where section numbers are referenced from each CLEC’s Attachment 3, the issue is common to all CLECs (*as is the case with all issues outside of Attachment 3*). With respect to Attachment 3 issues, where no section is listed from a CLEC’s agreement, that indicates that the individual issue raised is not of concern for the specific CLEC (e.g., Issue 3-6 lists section references for KMC and NewSouth only; it is not an issue for NuVox and Xspedius). There are 14 Attachment 3 issues, 4 of which are common among all parties, 4 of which are common to some but not all parties, and 6 of which are common only to Xspedius and BellSouth. Notably, many of the Xspedius/BellSouth issues are associated with related and advanced settlement negotiations on outstanding disputes. It is anticipated that many of these issues likely would be resolved as part of a settlement. Abbreviations used in association with Attachment 3 section references are as follows: “KMC” for KMC, “NSC” for NewSouth, “NVX” for NuVox, and “XSP” for Xspedius.

supplement, or modify their Joint Petition and/or issues list in the event additional disputed issues are identified or existing disputed issues are modified during the course of negotiations. Attached hereto and incorporated herein by reference as *Exhibit 2* is a “composite” interconnection agreement, which highlights the remaining unresolved issues between the parties.

**21.** The parties have attempted, where possible, to arrive at mutually agreeable statements of the issues. Where a mutual agreement has been reached, the Joint Petition reflects the issues as mutually framed by the parties, as well as their relevant positions. However, in instances where the parties have failed to agree on the framing of the issues, the Joint Petition reflects the issues as framed by the Joint Petitioners and omits BellSouth’s position, as requested by BellSouth. In addition, where the parties have neither agreed or disagreed on the framing of certain issues, as of the date of this filing, the Joint Petition omits BellSouth’s position, as requested by BellSouth. It is the Joint Petitioners’ understanding, based on BellSouth’s representations, that BellSouth will either concur in Joint Petitioners’ statement of such issues or provide an alternative statement with its Response (wherein BellSouth will also provide its position). The Joint Petitioners and BellSouth have represented to each other that they will attempt to reach agreement on as many of the issues statements as possible in the near future and will provide the Commission with an updated Joint Issues Matrix as soon as practicable.

## GENERAL TERMS AND CONDITIONS

*Issue No. G-1 [Section 1.6]: What should be the effective date of future rate impacting amendments?*

**CLECS' POSITION:** Future amendments incorporating Commission-approved rates should be effective as of the effective date of the Commission order, if an amendment is requested within 30 calendar days of that date. Otherwise, such amendments should be effective 10 calendar days after request.

**BELLSOUTH'S POSITION:** Future amendments incorporating Commission-approved rates should be effective ten (10) calendar days after the date of the last signature executing the amendment.

*Issue No. G-2 [Section 1.7]: How should "End User" be defined?*

**CLECS' POSITION:** The term "End User" should be defined as "the customer of a Party".

**BELLSOUTH'S POSITION:** BellSouth will provide its position with its Response.

*Issue No. G-3 [Section 10.2]: Should the Agreement contain a general provision providing that BellSouth shall take financial responsibility for its own actions in causing, or contributing to unbillable or uncollectible CLEC revenue in addition to specific provisions set forth in Attachments 3 and 7?*

**CLECS' POSITION:** YES, BellSouth should be financially liable for causing, failing to prevent, or contributing to unbillable or uncollectible CLEC revenue. A general provision complements the specific provisions contained in Attachments 3 and 7.

**BELLSOUTH'S POSITION:** NO. The Parties have negotiated specific provisions in Attachments 3 and 7 addressing responsibility for billing records deficiencies.

***Issue No. G-4 [Section 10.4.1]:*** *What should be the limitation on each Party's liability in circumstances other than gross negligence or willful misconduct?*

**CLECs' POSITION:** In cases other than gross negligence and willful misconduct by the other party, or other specified exemptions as set forth in CLECs' proposed language, liability should be limited to an aggregate amount over the entire term equal to 7.5% of the aggregate fees, charges or other amounts paid or payable for any and all services provided or to be provided pursuant to the Agreement as of the day immediately preceding the date of assertion or filing of the applicable claim or suit. CLECs' proposal represents a hybrid between limitation of liability provisions typically found in commercial contracts between sophisticated buyers and sellers, in the absence of overwhelming market dominance by one party, and the effective elimination of liability provision proposed by BellSouth.

**BELLSOUTH'S POSITION:** The industry standard limitation of liability should apply, which limits the liability of the provisioning party to a credit for the actual cost of the services or functions not performed or improperly performed.

***Issue No. G-5 [Section 10.4.2]:*** *Should each Party be required to include specific liability-eliminating terms in all of its tariffs and End User contracts (past, present and future), and, to the extent that a Party does not or is unable to do so, should it be obligated to indemnify the other Party for liabilities not eliminated?*

**CLECs' POSITION:** NO, BellSouth should not be able to dictate the terms of service between CLEC and its End Users by, among other things, holding CLEC liable for failing to mirror BellSouth's limitation of liability and indemnification provisions in CLEC's End User tariffs and/or contracts. To the extent that a Party does not, or is unable to, include specific elimination-of-liability terms in all of its tariffs and End User contracts (past, present and future), and

provided that the non-inclusion of such terms is commercially reasonable, that Party should not be required to indemnify and reimburse the other Party for that portion of the loss that would have been limited had the first Party included in its tariffs and contracts the elimination-of-liability terms that such other Party included in its tariffs at the time of such loss.

**BELLSOUTH'S POSITION:** BellSouth will provide its position with its Response.

*Issue No. G-6 [Section 10.4.4]: Should limitation on liability for indirect, incidental or consequential damages be construed to preclude liability for claims or suits for damages incurred by CLEC's (or BellSouth's) End Users to the extent such damages result directly and in a reasonably foreseeable manner from BellSouth's (or CLEC's) performance obligations set forth in the Agreement?*

**CLECs' POSITION:** NO, the Agreement, by its nature, contemplates that End Users will be served via the exchange of traffic through interconnection arrangements and through the use of UNEs and Other Services purchased. Damages to End Users that result directly and in a reasonably foreseeable manner from BellSouth's (or CLEC's) performance of obligations set forth in the Agreement that were not and are not directly and proximately caused by or are the result of CLEC's (or BellSouth's) failure to act at all relevant times in a commercially reasonable manner in compliance with CLEC's (or BellSouth's) duties of mitigation with respect to such damage should be considered direct under the Agreement for simple negligence purposes.

**BELLSOUTH'S POSITION:** BellSouth will provide its position with its Response.

*Issue No. G-7 [Section 10.5]: What should the indemnification obligations of the parties be under this Agreement?*

**CLECs' POSITION:** The Party providing service under the Agreement should be indemnified, defended and held harmless by the Party receiving services against any claim for libel, slander or



invasion of privacy arising from the content of the receiving Party's own communications. Similarly, the Party receiving services under the Agreement should be indemnified, defended and held harmless by the Party providing services against any claims, loss or damage to the extent arising from: (1) the providing Party's failure to abide by Applicable Law, or (2) injuries or damages arising out of or in connection with this Agreement to the extent caused by the providing Party's negligence, gross negligence or willful misconduct.

**BELLSOUTH'S POSITION:** The Party receiving services should indemnify the party providing services from (1) any claim loss or damages from claims for libel, slander or invasion of privacy arising from the content of the receiving party's own communications, or (2) any claim, loss or damage claimed by the end user of the party receiving services arising out of the Agreement.

*Issue No. G-8 [Section 11.1]: What language should be included in the Agreement regarding a Party's use of the other Party's name, service marks and trademarks?*

**CLECS' POSITION:** Given the complexity of and variability in intellectual property law, this nine-state Agreement should simply state that no patent, copyright, trademark or other proprietary right is licensed, granted or otherwise transferred by the Agreement and that a Party's use of the other Party's name, service mark and trademark should be in accordance with Applicable Law. The Commission should not attempt to prejudge intellectual property law issues, which at BellSouth's insistence, the Parties have agreed are best left to adjudication by courts of law (*see* GTC, Sec. 11.5).

**BELLSOUTH'S POSITION:** BellSouth will provide its position with its Response.

*Issue No. G-9 [Section 13.1]: Should a court of law be included among the venues at which a Party may seek dispute resolution under the Agreement?*

**CLECs' POSITION:** YES, either Party should be able to petition the Commission, the FCC or a court of law for resolution of a dispute. Given the difficulties experienced in achieving efficient regional dispute resolution, and the ongoing debate as to whether state commissions have jurisdiction to enforce agreements (CLECs do not dispute that authority) and as to whether the FCC will engage in such enforcement (or not), no legitimate dispute resolution venue should be foreclosed. There is no question that courts of law have jurisdiction to entertain such disputes (*see* GTC, Sec. 11.5); indeed, in certain instances, they may be better equipped to adjudicate a dispute and may provide a more efficient alternative to litigating in up to 9 different jurisdictions or to waiting for the FCC to decide whether it will or won't accept an enforcement role given the particular facts.

**BELLSOUTH'S POSITION:** BellSouth will provide its position with its Response.

*Issue No. G-10 [Section 17.4]: (A) How much notice should be given by a Party requesting a change of law amendment? (B) How much time must elapse before a Party may seek dispute resolution pursuant to the dispute resolution procedures of the agreement, absent successful negotiation of and agreement by the Parties on such an amendment?*

**CLECs' POSITION:** (A) The Party requesting renegotiation should give 15 calendar days notice.

(B) In the event that changes to the Agreement necessitated by a change of law are not renegotiated within 45 days after notice of renegotiation, either Party may invoke the Dispute Resolution procedures of the agreement, as it deems appropriate. The 45 day period is

not a deadline. Rather, it establishes a reasonable minimum time frame during which the Parties must attempt to negotiate an amendment without resorting to dispute resolution. After 45 days have passed, each Party should use discretion and good judgment prior to resorting to Dispute Resolution, as with respect to some amendments, it may take months to sort through the issues and complete a good faith attempt at reaching resolution without intervention.

**BELLSOUTH’S POSITION:** BellSouth will provide its position with its Response.

*Issue No. G-11 [Sections 19, 19.1]: For the purpose of bankruptcy law, should the Agreement be considered indivisible?*

**CLECs’ POSITION:** NO, it is neither necessary nor proper to amalgamate or pre-decide bankruptcy law in the context of this Agreement. All provisions of the Agreement were not negotiated as a “single whole” or as a “single transaction” and not all of the provisions or obligations set forth therein are “interdependent”. BellSouth’s proposed language impermissibly subverts, the requirements of section 252(i) of the Communications Act, FCC Rule 51.809, and Section 17.1 of the General Terms and Conditions.

**BELLSOUTH’S POSITION:** YES. The parties have negotiated this agreement as a whole and do not consider each attachment to be a separate contract, divisible from the general terms and conditions, and every other applicable attachment.

*Issue No. G-12 [Section 32.2]: Should the Agreement explicitly state that all existing state and federal laws, rules, regulations, and decisions apply unless otherwise specifically agreed to by the Parties?*

**CLECs’ POSITION:** YES, nothing in the Agreement should be construed to limit a Party’s rights or exempt a Party from obligations under Applicable Law, as defined in the Agreement, except

in such cases where the Parties have explicitly agreed to a limitation or exemption. This is a basic legal tenet and is consistent with both federal and Georgia law (agreed to by the parties), and it should be explicitly stated in the Agreement in order to avoid unnecessary disputes and litigation that has plagued the Parties in the past.

**BELLSOUTH’S POSITION:** This agreement constitutes the contractual obligations of the parties to each other and should not be subject to further negotiation subsequent to being fully negotiated and arbitrated.

*Issue No. G-13 [Section 32.3]: How should the Parties deal with non-negotiated deviations from the state Commission-approved rates in the rate sheets attached to the Agreement?*

**CLECs’ POSITION:** Any non-negotiated deviations from ordered rates should be corrected by retroactive true-up to the effective date of the Agreement within 30 calendar days of the date the error was identified by either Party.

**BELLSOUTH’S POSITION:** Any non-negotiated deviations from ordered rates should be changed by amendment of the agreement upon discovery by a party and should be applied prospectively regardless of whether the rate increases or decreases as a result of such amendment.

*Issue No. G-14 [Section 34.2]: Can either Party require, as a prerequisite to performance of its obligations under the Agreement, that the other Party adhere to any requirement other than those expressly stipulated in the Agreement or mandated by Applicable Law?*

**CLECs’ POSITION:** NO, the Parties should not be permitted to hold performance hostage to terms not included in the Agreement and not mandated by Applicable Law. More specifically, neither Party should, as a condition or prerequisite to such Party’s performance of its obligations under the Agreement, impose or insist upon the other Party’s (or any of its End Users’) performance of its obligations under the Agreement.

adherence to any requirement or obligation other than as expressly stipulated in this Agreement or as otherwise mandated by Applicable Law.

**BELLSOUTH'S POSITION:** YES. The Parties are free to negotiate with each other as they may with third parties. Neither Party should use this Agreement to interfere with a third party's contractual rights and obligations.

***Issue No. G-15 [Section 45.2]:** If BellSouth changes a provision of one or more of its Guides that would cause CLEC to incur a material cost or expense to implement the change, should the CLEC notify BellSouth, in writing, if it does not agree to the change?*

**CLECs' POSITION:** NO, if the contemplated change to one or more of BellSouth's Guides would cause CLEC to incur a material cost or expense to implement the change, BellSouth and CLEC should negotiate an amendment to the Agreement to incorporate such change.

**BELLSOUTH'S POSITION:** YES. BellSouth's Guides apply to all CLEC's equally. If BellSouth allows a CLEC the right to opt out of the requirements of a Guide, the CLEC should notify BellSouth of its decision to do so.

***Issue No. G-16 [Section 45.3]:** Should the obligations set forth in the Agreement be impacted by unreasonable and/or discriminatory revisions to BellSouth tariffs?*

**CLECs' POSITION:** NO, unreasonable and/or discriminatory revisions to BellSouth's tariffs should not affect the obligations set forth in the Agreement. Specifically, to the extent that tariff changes are inconsistent with the provisions of the Agreement, or are unreasonable or discriminatory, they should not supersede the Agreement. Such changes may only become part of the Agreement by written amendment negotiated and/or arbitrated by the Parties.

**BELLSOUTH'S POSITION:** BellSouth will provide its position with its Response.

**RESALE (ATTACHMENT 1)**

*Issue No. 1-1 [Section 3.19]: How much advance notice must BellSouth give CLEC before discontinuing a service or increasing the price of a service.*

**CLECS' POSITION:** BellSouth must provide electronically to CLEC forty-five (45) days advance notice of changes to the prices, terms or conditions of services available for Resale, including but not limited to, discontinuances and price increases.

**BELLSOUTH'S POSITION:** If a CLEC is under a Commission requirement to provide notice to its end users of price increases or discontinuance of services, BellSouth should provide 10 days notice prior to the CLEC's obligation to provide notice to its end users.

*Issue No. 1-2 [Section 11.6.6]: For the purpose of connecting to BellSouth's TOPS platform, should CLEC be entitled to purchase from BellSouth transport facilities and trunks at TELRIC-compliant rates where such transport facilities and trunks are available as UNEs?*

**CLECS' POSITION:** YES, for the purpose of connecting to BellSouth's TOPS, CLEC should be entitled to purchase from BellSouth transport facilities or trunks at TELRIC rates where such transport facilities and trunks are available as UNEs.

**BELLSOUTH'S POSITION:** BellSouth will provide its position with its Response.

## NETWORK ELEMENTS (ATTACHMENT 2)

*Issue No. 2-1 [Section 1.1]: (A) To what extent shall obligations set forth in FCC rules and orders and Commission rules and orders apply? (B) To the extent that there is a conflict between Attachment 2 and any other provision of the Agreement, should the provisions in Attachment 2 control?*

**CLECs' POSITION:** (A) In general, Attachment 2 is not intended to eliminate obligations set forth in FCC rules and orders and Commission rules and orders. However, to the extent obligations are addressed in the text of Attachment 2 and that text conflicts with obligations set forth in FCC rules and orders and Commission rules and orders, the text of Attachment 2 should prevail. Conversely, to the extent obligations set forth in FCC rules and orders and Commission rules and orders are not addressed in Attachment 2, those obligations should apply unless the text of Attachment 2 expressly states that a particular obligation does not apply.

(B) NO, CLECs are unaware of any conflicts between Attachment 2 and any other provision of the Agreement. Any conflicts that may arise or be alleged in the future should be addressed and evaluated on a case-by-case basis.

**BELLSOUTH'S POSITION:** BellSouth will provide its position with its Response.

*Issue No. 2-2 [Section 1.2]: (A) Should the Agreement contain a paraphrased version of a rule regarding CLEC obligations in lieu of direct references to rules governing both Parties' obligations? (B) Should references to FCC rules be construed as including or excluding relevant text from the FCC's Triennial Review Order?*

**CLECs' POSITION:** (A) NO, the Agreement should contain direct references to rules governing both Parties' obligations. (B) Direct references to FCC rules should be construed to include relevant text from the FCC's *Triennial Review Order*.

**BELLSOUTH’S POSITION:** BellSouth will provide its position with its Response.

*Issue No. 2-3 [Section 1.4.1]: Should the provision regarding the effective billing date for Conversions explicitly state that agreement to it by CLECs is made without admission or prejudice with respect to pre-existing disputes regarding this issue?*

**CLECs’ POSITION:** YES, given that the text of this provision represents a negotiated resolution to a controversial issue that has no intended retroactive effect on ongoing disputes between the Parties, it is appropriate to include such a disclaimer in the provision.

**BELLSOUTH’S POSITION:** BellSouth will provide its position with its Response.

*Issue No. 2-4 [Section 1.4.3]: (A) Should CLEC be required to submit a BFR/NBR to convert a UNE or Combination (or part thereof) to Other Services or tariffed BellSouth access services? (B) In the event of such conversion, what rates should apply?*

**CLECs’ POSITION:** (A) NO, CLEC should be allowed to submit an LSR or ASR, as appropriate. (B) For such conversion, the non-recurring charges should be as set forth in Exhibit A of Attachment 2 or the relevant tariff, as appropriate. In addition, such charges should be commensurate with the work required to effectuate the conversion (cross connect only, billing change/records update only, etc.).

**BELLSOUTH’S POSITION:** BellSouth will provide its position with its Response.



***Issue No. 2-5 [Section 1.5]:*** (A) In the event UNEs or Combinations are no longer offered pursuant to, or are not in compliance with, the terms set forth in this Agreement, which Party should bear the obligation of identifying those service arrangements? (B) What recourse may BellSouth take if CLEC does not submit a rearrange or disconnect order within 30 days? (C) What rates, terms and conditions should apply in the event of a termination, re-termination, or physical rearrangements of circuits?

**CLECs' POSITION:** (A) In the event UNEs or Combinations are no longer offered pursuant to, or are not in compliance with, the terms set forth in the Agreement, it should be BellSouth's obligation to identify the specific service arrangements that it insists be transitioned to other services pursuant to Attachment 2.

(B) If CLEC does not submit a rearrange or disconnect order within 30 days, BellSouth may disconnect such arrangements or services without further notice, provided that CLEC has not notified BellSouth of a dispute regarding the identification of specific service arrangements as being no longer offered pursuant to, or are not in compliance with, the terms set forth in the Agreement.

(C) For arrangements that require a re-termination or other physical rearrangement of circuits to comply with the terms of the Agreement, non-recurring charges for the applicable UNE or cross connect from Exhibit A of Attachment 2 should apply. Disconnect charges should not apply to services that are being physically rearranged or re-terminated.

**BELLSOUTH'S POSITION:** BellSouth will provide its position with its Response.

***Issue No. 2-6 [Section 1.5.1]:*** Should BellSouth be entitled to impose limitations on CLEC use of UNEs not permitted by Applicable Law?

**CLECs' POSITION:** NO, unless permitted under Applicable Law, BellSouth may not impose limitations on CLEC's ability to access and use UNEs.

**BELLSOUTH'S POSITION:** BellSouth will provide its position with its Response.

*Issue No. 2-7 [Section 1.6.1]: What rates, terms and conditions should apply for Routine Network Modifications pursuant to 47 C.F.R. § 51.319(a)(8) and (e)(5)?*

**CLECs' POSITION:** If BellSouth has anticipated such Routine Network Modifications and performs them during normal operations, then BellSouth should perform such Routine Network Modifications at no additional charge. If BellSouth has not anticipated a requested or necessary network modification as being a Routine Network Modification and, as such, has not recovered the costs of such Routine Network Modifications in the rates set forth in Exhibit A of Attachment 2, then BellSouth should notify CLEC of the required Routine Network Modification and should request that CLEC submit a Service Inquiry to have the work performed. Each *unique* request should be handled as a project on an individual case basis. BellSouth should provide a TELRIC-compliant price quote for the request, and upon receipt of a firm order from CLEC, BellSouth should perform the Routine Network Modification.

**BELLSOUTH'S POSITION:** BellSouth will provide its position with its Response.

*Issue No. 2-8 [Section 1.7]: Should BellSouth be required to commingle UNEs or Combinations with any service, network element or other offering that it is obligated to make available pursuant to Section 271 of the Act?*

**CLECs' POSITION:** YES, BellSouth should be required to commingle UNEs or Combinations with any service, network element, or other offering that it is obligated to make available pursuant to Section 271 of the Act.

**BELLSOUTH'S POSITION:** BellSouth will provide its position with its Response.

***Issue No. 2-9 [Section 1.8.3]:*** *When multiplexing equipment is attached to a commingled circuit, should the multiplexing equipment be billed per the jurisdictional authorization (Agreement or tariff) of the lower or higher bandwidth service?*

**CLECs' POSITION:** When multiplexing equipment is attached to a commingled circuit, the multiplexing equipment should be billed from the same jurisdictional authorization (Agreement or tariff) as the lower bandwidth service.

**BELLSOUTH'S POSITION:** BellSouth will provide its position with its Response.

***Issue No. 2-10 [Section 1.9.4]:*** *Should the recurring charges for UNEs, Combinations and Other Services be prorated based upon the number of days that the UNEs are in service?*

**CLECs' POSITION:** YES, the recurring charges for UNEs, Combinations, and Other Services should be prorated based upon the number of days that the UNEs, Combinations, and Other Services are in service.

**BELLSOUTH'S POSITION:** BellSouth will provide its position with its Response.

***Issue No. 2-11 [Section 2.1.1]:*** *Are the types of loops that BellSouth, pursuant to FCC Rule 319(a), is required to provide to CLEC limited to those that are (a) currently available and set forth in the Agreement or (b) set forth in the Agreement?*

**CLECs' POSITION:** The types of loops that BellSouth is required to provide to CLEC, pursuant to FCC Rule 319(a), should be limited to those that BellSouth currently offers and is required to unbundle as set forth in the Agreement. Other loop-types that may be developed and may be subject to FCC Rule 319(a) will be incorporated into the Agreement by amendment or the BFR process.

**BELLSOUTH'S POSITION:** BellSouth will provide its position with its Response.

*Issue No. 2-12 [Section 2.1.1.1]: Should the Agreement include a provision declaring that facilities that terminate to another carrier's switch or premises, a cell site, Mobile Switching Center or base station do not constitute loops?*

**CLECS' POSITION:** NO, the Agreement should not include a provision declaring that facilities that terminate to another carrier's switch or premises, a cell site, Mobile Switching Center, or base station do not constitute loops. Such a provision would be inconsistent with the FCC's Triennial Review Order.

**BELLSOUTH'S POSITION:** BellSouth will provide its position with its Response.

*Issue No. 2-13 [Section 2.1.1.2]: Should the Agreement require CLEC to purchase the entire bandwidth of a Loop, even in cases where such purchase is not required by Applicable Law?*

**CLECS' POSITION:** NO, CLEC should not be required to purchase the entire bandwidth of a Loop, except where required by Applicable Law.

**BELLSOUTH'S POSITION:** BellSouth will provide its position with its Response.

*Issue No. 2-14 [Sections 2.1.2, 2.1.2.1, 2.1.2.2]: (A) Should the Agreement contain provisions categorizing loops as either mass market loops or enterprise market loops? (B) If so, what should such provisions say?*

**CLECS' POSITION:** (A) YES, the Agreement should contain provisions categorizing loops as either mass market loops or enterprise market loops.

(B) Such provisions should state that there are two categories of UNE loops, namely, Mass Market Loops and Enterprise Loops. The provisions should further define Mass Market Loops as loops that deliver narrowband service, such as POTS, facsimile services and

DS0 level services as well as broadband services such as DSL services to residential and very small business customers. In addition, there should be a provision listing the three types of Mass Market Loops: copper loops, fiber-to-the-home loops, and hybrid fiber/copper loops. The provision should define Enterprise Market Loops as loops that deliver narrowband and broadband services to small, medium and large-sized businesses. Similarly, there should be a provision setting forth that Enterprise Loops, including DS1, DS-3/STS loops, and dark fiber loops are not subject to any of the restrictions applicable to Mass Market Loops, regardless of the transmission medium over which they are provided.

**BELLSOUTH'S POSITION:** BellSouth will provide its position with its Response.

*Issue No. 2-15 [Section 2.2.3]: Is unbundling relief provided under FCC Rule 319(a)(3) applicable to Fiber-to-the-Home Loops deployed prior to October 2, 2003?*

**CLECs' POSITION:** NO, the unbundling relief provided under FCC Rule 319(a)(3) is only applicable to Fiber-to-the-Home Loops deployed on or after October 2, 2003 (the effective date of the FCC's Triennial Review Order).

**BELLSOUTH'S POSITION:** BellSouth will provide its position with its Response.

*Issue No. 2-16 [Section 2.3.3]: How should Dark Fiber Loops be defined?*

**CLECs' POSITION:** Dark Fiber Loop should be defined as fiber within an existing fiber optic cable that has not been activated through the use of optronics to render it capable of carrying communications services that extends from the demarcation point at an End User's premises to the BellSouth central office.

**BELLSOUTH'S POSITION:** BellSouth will provide its position with its Response.

*Issue No. 2-17 [Sections 2.4.3, 2.4.4]: What rates should apply to testing and dispatch performed by BellSouth in response to a CLEC trouble report and in order to confirm the working status of a UNE Loop?*

**CLECS' POSITION:** TELRIC-compliant rates to be approved by the Commission and incorporated in Exhibit A of Attachment 2 should apply to testing and dispatch performed by BellSouth in response to a CLEC trouble report and in order to confirm the working status of a UNE Loop.

**BELLSOUTH'S POSITION:** BellSouth will provide its position with its Response.

*Issue No. 2-18 [Section 2.12.1]: (A) How should line conditioning be defined in the Agreement? (B) What should BellSouth's obligations be with respect to line conditioning?*

**CLECS' POSITION:** (A) Line Conditioning should be defined in the Agreement as set forth in FCC Rule 47 CFR 51.319 (a)(1)(iii)(A). (B) BellSouth should perform line conditioning in accordance with FCC Rule 47 C.F.R. 51.319 (a)(1)(iii). Insofar as it is technically feasible, BellSouth should test and report troubles for all the features, functions, and capabilities of conditioned copper lines, and may not restrict its testing to voice transmission only.

**BELLSOUTH'S POSITION:** BellSouth will provide its position with its Response.

*Issue No. 2-19 [Section 2.12.2]: Should the Agreement contain specific provisions limiting the availability of Line Conditioning to copper loops of 18,000 feet or less?*

**CLECS' POSITION:** NO, the agreement should not contain specific provisions limiting the availability of Line Conditioning to copper loops of 18,000 feet or less in length.

**BELLSOUTH'S POSITION:** BellSouth will provide its position with its Response.

***Issue No. 2-20 [Sections 2.12.3, 2.12.4]: Under what rates, terms and conditions should BellSouth be required to perform Line Conditioning to remove bridged taps?***

**CLECs' POSITION:** Any copper loop being ordered by CLEC which has over 6,000 feet of combined bridged tap will be modified, upon request from CLEC, so that the loop will have a maximum of 6,000 feet of bridged tap. This modification will be performed at no additional charge to CLEC. Line conditioning orders that require the removal of other bridged tap should be performed at the rates set forth in Exhibit A of Attachment 2.

**BELLSOUTH'S POSITION:** BellSouth will provide its position with its Response.

***Issue No. 2-21 [Section 2.12.6]: (A) Should the Agreement contain a provision barring Line Conditioning that would result in the modification of a Loop in such a way that it no longer meets technical parameters of the original Loop? (B) If not, should the resulting modified Loop be maintained as a non-service-specific Unbundled Copper Loop?***

**CLECs' POSITION:** (A) NO, CLEC should not be barred from requesting Line Conditioning that would result in the modification of a Loop in such a way that it no longer meets the technical parameters of the original Loop. (B) YES, the resulting modified Loop should be maintained as a non-service-specific Unbundled Copper Loop.

**BELLSOUTH'S POSITION:** BellSouth will provide its position with its Response.

***Issue No. 2-22 [Section 2.14.3.1.1]: Should BellSouth be required to allow CLEC to connect its Loops directly to BellSouth's multi-line residential NID enclosures that have spare terminations available?***

**CLECs' POSITION:** YES, the Commission should order BellSouth to allow CLEC to connect its Loops directly to BellSouth's multi-line residential NID enclosures that have spare terminations available.

**BELLSOUTH'S POSITION:** BellSouth will provide its position with its Response.

*Issue No. 2-23 [Sections 2.16.2.2, 2.16.2.3.1-5, 2.16.2.3.7-12]: (A) Should the provisions relating to BellSouth's obligation to provide Unbundled Network Terminating Wire (UNTW) apply to CLEC, as well?*

*(B) Should the obligation to provide UNTW apply when such premise wiring is leased? (2.16.2.2, 2.16.2.3.1)*

*(C) Should the obligation to provide access to UNTW be limited to existing UNTW? (2.16.2.3.2)*

*(D) Should CLECs have to agree to language that requires them to "ensure" that a customer that has asked to switch service to CLEC is already no longer using another carrier's service on that pair – or – will language obligating CLEC to use commercially reasonable efforts to access only an "available pair" suffice? (2.16.2.3.5)*

*(E) Should a time limit be placed on the obligation to reimburse costs associated with removing access terminals and restoring the property to its original state (per request of property owner)? (2.16.2.3.7)*

**CLECs' POSITION:** (A) NO, CLECs have expressly notified BellSouth that they are at the present time unwilling to negotiate such access to UNTW as CLECs have no legal obligation to make UNEs available to, or otherwise unbundle UNTW for, BellSouth.

(B) YES, BellSouth's legal obligation to provide UNTW applies even where the premises wiring is leased.

(C) NO, to the extent BellSouth would install new or additional UNTW beyond existing UNTW upon request from one of its own End Users, or is otherwise required to do so in order to comply with FCC or Commission rules and orders, BellSouth should be obligated to provide access to such new or additional UNTW beyond existing UNTW.



(D) CLEC should not be required to “ensure” that a customer that has asked to switch service to CLEC is no longer using another carrier’s service on a particular pair. Rather, a provision obligating CLEC to use commercially reasonable efforts to access only an “available pair” should be sufficient.

(E) YES, there should be a time limit on reimbursement obligations. Specifically, CLEC should be responsible for costs associated with removing access terminals and restoring the property to its original state only when the property owner objects to and demands removal of access terminal installations that are in progress or within thirty (30) calendar days of completion.

**BELLSOUTH’S POSITION:** BellSouth will provide its position with its Response.

*Issue No. 2-24 [Section 2.17.3.5]: Should BellSouth be required to provide access to Dark Fiber Loops for test access and testing at any technically feasible point?*

**CLECS’ POSITION:** YES, BellSouth should be required to provide access to Dark Fiber Loops for test access and testing at any technically feasible point, the termination point within a serving wire center, and CLEC’s End User’s premises.

**BELLSOUTH’S POSITION:** BellSouth will provide its position with its Response.

*Issue No. 2-25 [Section 2.18.1.4]: Under what circumstances should BellSouth provide CLEC Loop Makeup information?*

**CLECS’ POSITION:** BellSouth should provide CLEC Loop Makeup information on a particular loop upon request by CLEC. Such access should not be contingent upon receipt of an LOA from a third party carrier.

**BELLSOUTH’S POSITION:** BellSouth will provide its position with its Response.

*Issue No. 2-26 [Section 3.6.5]: When Line Sharing is provisioned, what provisions should apply when BellSouth receives a voice trouble and isolates the trouble to a physical collocation arrangement belonging to CLEC?*

**CLECs' POSITION:** When Line Sharing is provisioned, the following provisions should apply when BellSouth receives a voice trouble and isolates the trouble to a physical collocation arrangement belonging to CLEC: When BellSouth receives a voice trouble and isolates the trouble to the physical collocation arrangement belonging to CLEC, BellSouth should notify CLEC. CLEC should respond by providing at least one (1) but no more than two (2) verbal CFA pair changes to BellSouth in an attempt to resolve the voice trouble. In the event a CFA pair change resolves the voice trouble, CLEC should provide BellSouth an LSR with the new CFA pair information within twenty-four (24) hours (excluding Saturdays, Sundays and Holidays) of receiving notification from BellSouth of such resolution. No charges should apply for submission of such LSR. If CLEC fails to respond to a BellSouth request for verbal CFA pair changes within twenty-four (24) hours (excluding Saturdays, Sundays and Holidays) of CLEC's Maintenance Service Center receiving notification from BellSouth, BellSouth may suspend CLEC's access to the High Frequency Spectrum on such Loop.

**BELLSOUTH'S POSITION:** BellSouth will provide its position with its Response.

*Issue No. 2-27 [Section 3.10.3]: What should be CLEC's indemnification obligations under a line splitting arrangement?*

**CLECs' POSITION:** If CLEC is purchasing line splitting, and it is not the data provider, CLEC should indemnify, defend and hold harmless BellSouth from and against any claims, losses, actions, causes of action, suits, demands, damages, injury, and costs (including reasonable attorney fees) reasonably arising or resulting from the actions taken by the data provider in

connection with the line splitting arrangement, except to the extent caused by BellSouth's gross negligence or willful misconduct.

**BELLSOUTH'S POSITION:** BellSouth will provide its position with its Response.

*Issue No. 2-28 [Section 3.10.4]: (A) In cases where CLEC purchases UNEs from BellSouth, should BellSouth be required not to refuse to provide DSL transport or DSL services (of any kind) to CLEC and its End Users, unless BellSouth has been expressly permitted to do so by the Commission?*

*(B) Where BellSouth provides such transport or services to CLEC and its End Users, should BellSouth be required to do so without charge until such time as it produces an amendment proposal and the Parties amend this Agreement to incorporate terms that are no less favorable, in any respect, than the rates, terms and conditions pursuant to which BellSouth provides such transport and services to any other entity?*

**CLECs' POSITION:** (A) YES, in cases where CLEC purchases UNEs from BellSouth, BellSouth should not refuse to provide DSL transport or DSL services (of any kind) to CLEC and its End Users, unless BellSouth has been expressly permitted to do so by the Commission.

(B) YES, where BellSouth provides such transport or services to CLEC and its End Users, BellSouth should be required to do so without charge until such time as it produces an amendment proposal and the Parties amend this Agreement to incorporate terms that are no less favorable, in any respect, than the rates, terms and conditions pursuant to which BellSouth provides such transport and services to any other entity.

**BELLSOUTH'S POSITION:** BellSouth will provide its position with its Response.

***Issue No. 2-29 [Section 4.2.2]: (A) Should BellSouth be entitled to a greater limitation on its duty to unbundle Local Circuit Switching than currently prescribed by the FCC?***

***(B) Should the Agreement include a provision that requires CLEC to do something prior to the Effective Date?***

**CLECs' POSITION:** (A) NO, the limitations imposed on BellSouth's duty to unbundle Local Circuit Switching should be consistent with the limitations prescribed by the FCC.

(B) NO, to the extent the Effective Date is later than April 1, 2004, CLEC should not be required to submit orders to terminate, prior to the Effective Date, unbundled local circuit switching for CLEC when CLEC serves an End User with a DS1 or higher capacity Loop prior to the Effective Date.

**BELLSOUTH'S POSITION:** BellSouth will provide its position with its Response.

***Issue No. 2-30 [Section 4.5.5]: Should CLEC be entitled to purchase transport facilities and trunks used to connect to BellSouth's TOPS at TELRIC-compliant rates?***

**CLECs' POSITION:** YES, CLEC should be entitled to purchase transport facilities and trunks used to connect to BellSouth's TOPS at TELRIC-compliant rates.

**BELLSOUTH'S POSITION:** BellSouth will provide its position with its Response.

***Issue No. 2-31 [Section 5.2.4]: Under what conditions, if any, may BellSouth deny or delay a CLEC request to convert a circuit to a high capacity EEL?***

**CLECs' POSITION:** BellSouth may not deny or delay CLEC's request for a high-capacity EEL based upon its own assessment of compliance with eligibility criteria. However, BellSouth may notify CLEC when it detects an order that it does not believe complies with the eligibility criteria. CLEC will then have the option of proceeding with, modifying or canceling such order.

**BELLSOUTH’S POSITION:** BellSouth will provide its position with its Response.

*Issue No. 2-32 [Sections 5.2.5.2.1-7]: Should the high capacity EEL eligibility criteria use the term “customer”, as used in the FCC’s rules, or “End User”?*

**CLECs’ POSITION:** The high capacity EEL eligibility criteria should be consistent with those set forth in the FCC’s rules and should use the term “customer”, as used in the FCC’s rules. Use of the term “End User” may result in a deviation from the FCC rules to which CLECs are unwilling to agree.

**BELLSOUTH’S POSITION:** BellSouth will provide its position with its Response.

*Issue No. 2-33 [Sections 5.2.6, 5.2.6.1, 5.2.6.2, 5.2.6.2.1, 5.2.6.2.3]: (A) How often, and under what circumstances, should BellSouth be able to audit CLEC’s records to verify compliance with the high capacity EEL service eligibility criteria?*

*(B) Should there be a notice requirement for BellSouth to conduct an audit and what should the notice include?*

*(C) Who should conduct the audit and how should the audit be performed?*

**CLECs’ POSITION:** (A) BellSouth may, no more frequently than on an annual basis, and only based upon cause, conduct a limited audit of CLEC’s records in order to verify compliance with the high capacity EEL service eligibility criteria.

(B) YES, to invoke its limited right to audit, BellSouth should send a Notice of Audit to CLEC, identifying the particular circuits for which BellSouth alleges non-compliance and the cause upon which BellSouth rests its allegations. The Notice of Audit should also include all supporting documentation upon which BellSouth establishes the cause that forms the basis of BellSouth’s allegations of noncompliance. Such Notice of Audit should be delivered to

CLEC with all supporting documentation no less than thirty (30) days prior to the date upon which BellSouth seeks to commence an audit.

(C) The audit should be conducted by a third party independent auditor mutually agreed-upon by the Parties and retained and paid for by BellSouth. The audit should commence at a mutually agreeable location (or locations) no sooner than thirty (30) days after the parties have reached agreement on the auditor. In addition, the audit should be performed in accordance with the standards established by the American Institute for Certified Public Accountants (AICPA) which will require the auditor to perform an “examination engagement” and issue an opinion regarding CLEC’s compliance with the high capacity EEL eligibility criteria. AICPA standards and other requirements related to determining the independence of an auditor will govern the audit of requesting carrier compliance. The concept of materiality should govern this audit; the independent auditor’s report should conclude whether or the extent to which CLEC complied in all material respects with the applicable service eligibility criteria. Consistent with standard auditing practices, such audits should require compliance testing designed by the independent auditor, which typically includes an examination of a sample selected in accordance with the independent auditor’s judgment.

**BELLSOUTH’S POSITION:** BellSouth will provide its position with its Response.

*Issue No. 2-34 [Section 5.2.8]: When should CLEC be required to reimburse BellSouth for the cost of the independent auditor?*

**CLECS’ POSITION:** As expressly set forth in the FCC’s Triennial Review Order, in the event the auditor’s report concludes that CLEC did not comply in all material respects with the service eligibility criteria, CLEC shall reimburse BellSouth for the cost of the independent auditor.

**BELLSOUTH’S POSITION:** BellSouth will provide its position with its Response.

*Issue No. 2-35 [Section 6.1.1]: How should Dedicated Transport be defined?*

**CLECs' POSITION:** Dedicated Transport should be defined as set forth in 47 C.F.R. 319(e). The definition should also encompass the FCC's definition articulated in the Triennial Review Order, to wit: "Dedicated Transport is defined as BellSouth's interoffice transmission facilities, dedicated to a particular customer or carrier that CLEC uses for transmission between wire centers or switches owned by BellSouth and to the extent that BellSouth has local switching equipment, as defined by the FCC's rules, "reverse collocated" in a non-incumbent LEC premises, the transmission path from this point back to the BellSouth wire center shall be unbundled as transport between incumbent LEC switches or wire centers to the extent specified in part 51 of the FCC's rules within the same LATA."

**BELLSOUTH'S POSITION:** BellSouth will provide its position with its Response.

*Issue No. 2-36 [Section 6.1.1.1]: How should Dark Fiber Transport be defined?*

**CLECs' POSITION:** Dark Fiber Transport should be defined as set forth in FCC Rule 47 CFR 319(e).

**BELLSOUTH'S POSITION:** BellSouth will provide its position with its Response.

*Issue No. 2-37 [Section 6.4.2]: What terms should govern CLEC access to test and splice Dark Fiber Transport?*

**CLECs' POSITION:** CLEC should be able to splice and test Dark Fiber Transport obtained from BellSouth at any technically feasible point, using CLEC or CLEC-designated personnel. BellSouth must provide appropriate interfaces to allow splicing and testing of Dark Fiber.

**BELLSOUTH'S POSITION:** BellSouth will provide its position with its Response.

*Issue No. 2-38 [Sections 7.2, 7.3]: Should BellSouth's obligation to provide signaling link transport and SS7 interconnection at TELRIC-based rates be limited to circumstances in which BellSouth is required to provide and is providing to CLEC unbundled access to Local Circuit Switching?*

**CLECs' POSITION:** NO, BellSouth's obligation to provide signaling link transport and SS7 interconnection at TELRIC-based rates should not be limited to circumstances in which BellSouth is required to provide and is providing to CLEC unbundled access to Local Circuit Switching.

**BELLSOUTH'S POSITION:** BellSouth will provide its position with its Response.

*Issue No. 2-39 [Sections 7.4]: Should the Parties be obligated to perform CNAM queries and pass such information on all calls exchanged between them, regardless of whether that would require BellSouth to query a third party database provider?*

**CLECs' POSITION:** YES, the Parties should be obligated to perform CNAM queries and pass such information on all calls exchanged between them, regardless of whether that would require BellSouth to query a third party database provider.

**BELLSOUTH'S POSITION:** BellSouth will provide its position with its Response.

*Issue No. 2-40 [Sections 9.3.5]: Should LIDB charges be subject to application of jurisdictional factors?*

**CLECs' POSITION:** No, LIDB charges should not be subject to application of jurisdictional factors.

**BELLSOUTH'S POSITION:** BellSouth will provide its position with its Response.



*Issue No. 2-41 [Sections 14.1]: What terms should govern BellSouth's obligation to provide access to OSS?*

**CLECs' POSITION:** BellSouth must provide CLEC with nondiscriminatory access to operations support systems on an unbundled basis, in accordance with 47 CFR 51.319(g) and as set forth in Attachment 6. Operations support system ("OSS") functions consist of pre-ordering, ordering, provisioning, maintenance and repair, and billing functions supported by BellSouth's databases and information. BellSouth, as part of its duty to provide access to the pre-ordering function, must provide CLEC with nondiscriminatory access to the same detailed information about the loop that is available to BellSouth.

**BELLSOUTH'S POSITION:** BellSouth will provide its position with its Response.

### **INTERCONNECTION (ATTACHMENT 3)**

*Issue No. 3-1 [Section 3.3.4 (KMC, NSC, NVX), 3.3.3 XSP]: Should CLEC be permitted to connect to BellSouth's switch via a Cross Connect or any other technically feasible means of interconnection?*

**CLECs' POSITION:** YES, in the event that a Party's Point of Presence is located within any serving wire center (*i.e.*, switch location), such Party may interconnect to the other Party's switch via a Cross Connect or any other technically feasible means of interconnection.

**BELLSOUTH'S POSITION:** BellSouth will provide its position with its Response.

**Issue No. 3-2 [Section 9.6 (KMC), 9.6/7 (NSC), 9.6 (NVX, XSP)]:** (A) Should BellSouth be required to provide upon request, for any trunk group outage that has occurred 3 or more times in a 60 day period, a written root cause analysis report? (B) What target interval should apply for the delivery of such reports, as well as for those for global outages?

**CLECs' POSITION:** (A) YES, upon request, BellSouth should provide a written root cause analysis report for all global outages, and for any trunk group outage that has occurred 3 or more times in a 60 day period. (B) BellSouth should use best efforts to provide global outage and trunk group outage root cause analysis reports within five (5) business days of request.

**BELLSOUTH'S POSITION:** BellSouth will provide its position with its Response.

**Issue No. 3-3 [Section 10.9.5 (KMC), 10.7.4 (NSC), 10.7.4 (NVX), 10.12.4 (XSP)]:** What provisions should apply regarding records exchange necessary for the billing and collection of access revenues?

**CLECs' POSITION:** In the event that either Party fails to provide accurate switched access detailed usage data to the other Party *within 90 days* after the recording date and the receiving Party is unable to bill and/or collect access revenues due to the sending Party's failure to provide such data within said time period, then the Party failing to send the specified data should be liable to the other Party in an amount equal to the unbillable or uncollectible revenues.

**BELLSOUTH'S POSITION:** BellSouth will provide its position with its Response.

***Issue No. 3-4 [Section 10.10.6 (KMC), 10.8.6 (NSC), 10.8.6 (NVX), 10.13.5 (XSP)]: Under what terms should CLEC be obligated to reimburse BellSouth for amounts BellSouth pays to third party carriers that terminate BellSouth transited/CLEC originated traffic?***

**CLECS' POSITION:** In the event that a terminating third party carrier imposes on BellSouth any charges or costs for the delivery of Transit Traffic originated by CLEC, CLEC should reimburse BellSouth for all charges paid by BellSouth, which BellSouth is contractually obligated to pay. BellSouth should diligently review, dispute and pay such third party invoices (or equivalent) in a manner that is at parity with its own practices for reviewing, disputing and paying such invoices (or equivalent) when no similar reimbursement provision applies.

**BELLSOUTH'S POSITION:** BellSouth will provide its position with its Response.

***Issue No. 3-5 [Section 10.7.4.2 (KMC), 10.5.5.2 (NSC), 10.5.6.2 (NVX)]: While a dispute over jurisdictional factors is pending, should factors reported by the originating party remain in place, unless the parties mutually agree otherwise?***

**CLECS' POSITION:** YES, in the event that negotiations and audits fail to resolve disputes between the Parties, either Party may seek Dispute Resolution as set forth in the General Terms and Conditions. While such a dispute is pending, factors reported by the originating Party should remain in place, unless the Parties mutually agree otherwise.

**BELLSOUTH'S POSITION:** BellSouth will provide its position with its Response.

***Issue No. 3-6 [Section 10.10. 1 (KMC), 10.8.1 (NSC)]:***  
*Should BellSouth be able to impose upon CLEC a Tandem Intermediary Charge for the transport and termination of Local Transit Traffic and ISP-Bound Transit Traffic?*

**CLECs' POSITION:** NO, BellSouth should not be permitted to impose upon CLEC a Tandem Intermediary Charge (“TIC”) for the transport and termination of Local Transit Traffic and ISP-Bound Transit Traffic. The TIC is a non-TELRIC based additive charge which exploits BellSouth’s market power and is discriminatory.

**BELLSOUTH’S POSITION:** BellSouth will provide its position with its Response.

***Issue No. 3-7 [Section 10.1 (KMC),10.1 (XSP)]:*** *Should CLEC be entitled to symmetrical reciprocal compensation for the transport and termination of Local Traffic at the tandem interconnection rate?*

**CLECs' POSITION:** YES, CLEC should be entitled to bill, and BellSouth should be obligated to pay, reciprocal compensation for the transport and termination of Local Traffic to CLEC at a symmetrical tandem interconnection rate, inclusive of end office switching, tandem switching, and transport.

**BELLSOUTH’S POSITION:** BellSouth will provide its position with its Response.

***Issue No. 3-8 [Section 10.2, 10.2.1 (KMC), 10.2, 10.3 (XSP)]:*** *Should compensation for the transport and termination of ISP-bound Traffic be subject to a cap?*

**CLECs' POSITION:** NO, compensation caps set in the FCC’s remanded *ISP Order on Remand* do not extend beyond 2003.

**BELLSOUTH’S POSITION:** BellSouth will provide its position with its Response.

*Issue No. 3-9 [Section 2.1.12 (XSP)]: How should Local Traffic be defined?*

**CLECS' POSITION:** Local Traffic should be defined as any telephone call that originates in one exchange and is terminated in either the same exchange, or other mandatory local calling area associated with the originating exchange (e.g., mandatory Extended Area Service) as defined and specified in Section A3 of BellSouth's GSST. Designation of Local Traffic should not be dependent on the type of switching technology used to switch and terminate such Local Traffic, including use of frame switching. Local Traffic includes any cross boundary, intrastate, interLATA or interstate, interLATA calls established as a local call by the ruling regulatory body.

**BELLSOUTH'S POSITION:** BellSouth will provide its position with its Response.

*Issue No. 3-10 [Section 3.2 (XSP), Ex. A (XSP)]: (A) Should BellSouth be required to provide CLEC with OCn level interconnection at TELRIC-compliant rates? (B) What should those rates be?*

**CLECS' POSITION:** (A) YES, OCn level interconnection is technically feasible and must be made available at TELRIC-compliant rates. (B) TELRIC compliant rates for OCn interconnection trunks and facilities should be set by the Commission.

**BELLSOUTH'S POSITION:** BellSouth will provide its position with its Response.

*Issue No. 3-11 [Sections 3.3.1, 3.3.2, 3.4.5, 10.10.2 (XSP)]: Should cost-based interconnection (i.e., TELRIC), be limited to the percentage of facilities used for "local" traffic?*

**CLECS' POSITION:** NO, cost-based interconnection should not be limited to the percentage of facilities used for "local" traffic ("PLF"). CLEC is entitled to cost based interconnection for telephone exchange and exchange access traffic.

**BELLSOUTH'S POSITION:** BellSouth will provide its position with its Response.

*Issue No. 3-12 [Section 4.5 (XSP)]: What rate should apply in the event that a rate is not set forth in Exhibit A?*

**CLECs' POSITION:** To the extent a rate associated with interconnection trunks and facilities is not set forth in Exhibit A of Attachment 3, and no Commission-approved rate has been set, the rate should be negotiated by the Parties.

**BELLSOUTH'S POSITION:** BellSouth will provide its position with its Response.

*Issue No. 3-13 [Section 4.6 (XSP)]: Should the costs of two-way interconnection trunks facilities be split (a) proportionally based on the percentage of traffic originated by each Party or (b) in half?*

**CLECs' POSITION:** For two-way trunk groups that carry only both Parties' non-transit and non-interLATA Switched Access Traffic, each Party should pay its proportionate share of the recurring charges for trunks and associated facilities and nonrecurring charges for additional trunks and associated facilities based on the percentage of the total traffic originated by that Party. The Parties should determine the applicable percentages twice per year based on the previous six months minutes of use billed by each Party. Each Party should pay its proportionate share of initial facilities based on the joint forecasts for circuits required by each Party.

**BELLSOUTH'S POSITION:** BellSouth will provide its position with its Response.

*Issue No. 3-14 [Sections 10.10.4, 10.10.5, 10.10.6, 10.10.7 (XSP)]: Should CLEC be permitted to bill BellSouth based on actual traffic measurements, in lieu of BellSouth-reported jurisdictional factors?*

**CLECs' POSITION:** YES, where CLEC has message recording technology that identifies the jurisdiction of traffic terminated as defined in the Agreement, CLEC should have the option of

using that information to bill BellSouth based upon actual measurements and jurisdictionalization, in lieu of factors reported by BellSouth.

**BELLSOUTH’S POSITION:** BellSouth will provide its position with its Response.

#### **COLLOCATION (ATTACHMENT 4)**

*Issue No. 4-1 [Section 3.9]: What definition of “Cross Connect” should be included in the Agreement?*

**CLECs’ POSITION:** The following definition of “Cross Connect” should be included in the Agreement: “A cross-connection (Cross Connect) is a cabling scheme between cabling runs subsystems, and equipment using patch cords or jumper wires that attach to connection hardware on each end, as defined and described by the FCC in its applicable rules and orders.” In addition to the FCC’s definition, the following language should be added for clarity: “A Cross Connect involved in the provision of services not associated with a collocation arrangement is not ordered but is a part of the provisioning of the service.”

**BELLSOUTH’S POSITION:** BellSouth will provide its position with its Response.

*Issue No. 4-2 [Sections 5.21.1, 5.21.2]: With respect to interference and impairment issues raised outside of the scope of the FCC Rule 51.233 (which relates to the deployment of Advanced Services equipment) what provisions should be included in the Agreement?*

**CLECs’ POSITION:** Provisions should be included to cover the installation and operation of any equipment or services that (1) significantly degrades (“significantly degrades” is as in the FCC rule applicable to Advanced Services); (2) endangers or damages the equipment or facilities of any other telecommunications carrier collocated in the Premises; or (3) knowingly and

unlawfully compromises the privacy of communications routed through the Premises; and (4) creates an unreasonable risk of injury or death to any individual or to the public.

The Agreement also should provide that if BellSouth reasonably determines that any equipment or facilities of CLEC violates the provisions of Section 5.21, BellSouth should provide written notice to CLEC requesting that CLEC cure the violation within forty-eight (48) hours of actual receipt of written notice or, at a minimum, to commence curative measures within twenty-four (24) hours and to exercise reasonable diligence to complete such measures as soon as possible thereafter.

The Agreement also should state that, with the exception of instances which pose an immediate and substantial threat of physical damage to property or injury or death to any person, disputes regarding the source of the risk, impairment, interference, or degradation should be resolved pursuant to the Dispute Resolution provisions set forth in the General Terms and Conditions.

**BELLSOUTH'S POSITION:** BellSouth will provide its position with its Response.

*Issue No. 4-3 [Section 8.1]: Where grandfathering is appropriate, which rates should apply?*

**CLECS' POSITION:** When rates have been “grandfathered,” the rates that will apply are those rates that were in effect prior to the Effective Date of the Agreement, unless application of such rates would be inconsistent with the underlying purpose for grandfathering.

**BELLSOUTH'S POSITION:** BellSouth will provide its position with its Response.



*Issue No. 4-4 [Section 8.4]: When should BellSouth commence billing of recurring charges for power?*

**CLECs' POSITION:** Billing for recurring charges for power provided by BellSouth should commence on the date upon which the primary and redundant connections from CLEC's equipment in the Collocation Space to the BellSouth power board or BDFB are installed.

**BELLSOUTH'S POSITION:** Billing for power provided by BellSouth should commence on the Space Acceptance Date or the Space Ready Date if a Space Acceptance inspection does not occur within 15 calendar days of the Space Ready Date.

*Issue No. 4-5 [Section 8.6]: Should CLEC be required to pay space preparation fees and charges with respect to collocations when it already has paid space preparation charges through ICB or NRC pricing?*

**CLECs' POSITION:** NO, space preparation fees should not apply when CLEC already has paid space preparation charges through previously billed ICB or non-recurring space preparation charges.

**BELLSOUTH'S POSITION:** BellSouth will provide its position with its Response.

*Issue No. 4-6 [Sections 8.11, 8.11.1, 8.12.2]: What rates should apply for BellSouth-supplied DC power?*

**CLECs' POSITION:** Applicable rates should vary depending on whether\_CLEC elects to be billed on a "fused amp" basis, by electing to remain (or install new collocations or augments) under the traditional collocation power billing method, or on a "used amp" basis, by electing to convert collocations to (or install new collocations or augments under) the power usage metering option set forth in Section 9 of Attachment 4. Under either billing method, there will be rates applicable to grandfathered collocations for which power plant infrastructure costs have been

prepaid under an ICB pricing or non-recurring charge arrangement, and there will be rates applicable where such grandfathering does not apply and power plant infrastructure is instead recovered via recurring charges, as currently set by the Commission.

Under the fused amp billing option, CLEC will be billed at the Commission's most recently approved fused amp recurring rate for DC power. However, if certain arrangements are grandfathered as a result of CLEC having paid installation costs under an ICB or non-recurring rate schedule for the collocation arrangement power installation, CLEC should only be billed the recurring rate for the DC power in effect prior to the Effective Date of this Agreement, or, if rates that excluded the infrastructure component had not been incorporated into the Parties' most recent Agreement, the most recent Commission approved rate that does not include an infrastructure component should apply.

Under the power usage metering option, recurring charges for DC power are subdivided into a power infrastructure component and an AC usage component (based on DC amps consumed). However, if certain arrangements are grandfathered as a result of CLEC having paid installation costs under an ICB or non-recurring rate schedule for the collocation arrangement power installation, CLEC should only be billed a recurring rate for the AC usage based on the most recent Commission approved rate exclusive of an infrastructure component (as set by the Commission).

**BELLSOUTH'S POSITION:** BellSouth will provide its position with its Response.

*Issue No. 4-7 [Section 9.1.1]: Under the fused amp billing option, how will recurring and non-recurring charges be applied and what should those charges be?*

**CLECs' POSITION:** Under the fused amp billing option, monthly recurring charges for -48V DC power should be assessed per fused amp per month in a manner consistent with Commission

orders and as set forth in Section 8 of Attachment 4 (*see* Issue 4-6 above). Non-recurring charges for –48V DC power distribution, should be as prescribed by the Commission.

**BELLSOUTH’S POSITION:** BellSouth will provide its position with its Response.

*Issue No. 4-8 [Sections 9.1.2, 9.1.3]: (A) Should CLEC be permitted to choose between a fused amp billing option and a power usage metering option in states other than and in addition to Tennessee (where the choice already is available)? (B) Under the power usage metering option, how will recurring and non-recurring charges be applied and what should those charges be?*

**CLECs’ POSITION:** (A) YES, CLEC should be permitted to choose between a fused amp billing option and a power usage metering option in states other than and in addition to Tennessee. (B) If CLEC chooses the power usage metering option, monthly recurring charges for -48V DC power will be assessed based on a consumption component and, if applicable, an infrastructure component, as set forth in Section 8 of Attachment 4 (*see* Issue 4-6 above). The Commission should ensure that its most recently approved recurring rates are apportioned appropriately into the consumption and infrastructure components. Nonrecurring charges for -48V DC power distribution should be as prescribed by the Commission.

**BELLSOUTH’S POSITION:** BellSouth will provide its position with its Response.

*Issue No. 4-9 [Sections 9.3]: For BellSouth-supplied AC power, should CLEC be entitled to choose between a fused amp billing option and a power usage metering option?*

**CLECs’ POSITION:** YES, where CLEC elects to install its own DC Power Plant, and BellSouth provides Alternating Current (AC) power to feed CLEC’s DC Power Plant, CLEC should have the option of choosing between fused amp billing and power usage metering options.

**BELLSOUTH’S POSITION:** BellSouth will provide its position with its Response.

*Issue No. 4-10 [Sections 13.6]: (A) Should BellSouth have the right to request the removal from BellSouth's Premises of a CLEC employee where the CLEC employee has not been found to have interfered with the property or personnel of BellSouth or another telecommunications carrier in a significant and material way? (B) In instances where interference caused by CLEC employee has not been found to have interfered with the property or personnel of BellSouth or another telecommunications carrier in a significant and material way, should the Parties be required to cooperate to ensure that appropriate remedial measures are taken that are less likely to have a significant impact on CLEC's daily operations?*

**CLECs' POSITION:** (A) NO, only in cases where CLEC employee is found interfering with the property or personnel of BellSouth or another telecommunications carrier in a significant and material way should BellSouth be entitled to request prompt removal and suspension of access from BellSouth's Premises for any employee of CLEC to whom BellSouth does not wish to grant access pursuant to an investigation to be conducted by BellSouth. (B) YES, in instances where interference caused by CLEC employee has not been found to have interfered with the property or personnel of BellSouth or another telecommunications carrier in a significant and material way, the Parties should be required to cooperate and communicate, to the extent circumstances permit, to ensure that the Parties may take appropriate remedial measures and so that CLEC personnel are not denied access for activity that does not have a significant and material impact and that would be more suitably addressed through disciplinary measures less likely to have a significant impact on CLEC's daily operations.

**BELLSOUTH'S POSITION:** BellSouth will provide its position with its Response.

## ORDERING (ATTACHMENT 6)

*Issue No. 6-1 [Section 2.5.1]: Should payment history be included in the CSR?*

**CLECs' POSITION:** YES, the subscribers' payment history should be included in the CSR to the extent authorized or required by the FCC, Commission or End User.

**BELLSOUTH'S POSITION:** NO, payment history should be maintained as confidential information and is not necessary in order for a CLEC to provision service to an end user. BellSouth's systems will not permit this information to be shared on an end user by end user or CLEC by CLEC basis.

*Issue No. 6-2 [Section 2.5.5]: Should CLEC have to provide BellSouth with access to CSRs within firm intervals?*

**CLECs' POSITION:** NO, CLEC is not required by law to commit to specific intervals, and does not have any automated system in place to handle CSR requests. Moreover, BellSouth refuses to commit to deliver CSRs within a firm interval. CLEC, however, will commit to use its best efforts to provide CSRs within an average of 5 business days of a valid request, subject to the same exclusions applicable to BST's delivery of CSRs.

**BELLSOUTH'S POSITION:** YES, BellSouth is required to provide CSRs to CLEC in intervals prescribed by this Commission which, if not met, require BellSouth to remit SEEMs penalties. If CLEC is not held to the same standard, the End User customer is impaired by being unable to receive the same service interval from all local service providers.

*Issue No. 6-3 [Sections 2.5.6.2, 2.5.6.3]: (A) What procedures should apply when one Party alleges, via written notice, that the other Party has engaged in unauthorized access to CSR information? (B) How should disputes over alleged unauthorized access to CSR information be handled under the Agreement?*

**CLECs' POSITION:** (A) Either Party, in the event it suspects that the other Party has accessed CSR information without having obtained the proper End User authorization, should send written notice to the other Party specifying the alleged noncompliance. The Party receiving the notice should be obligated to acknowledge receipt of the notice as soon as practicable, and provide appropriate proof of authorization within seven (7) days or provide notice that appropriate corrective measures have been taken or will be taken as soon as practicable.

(B) If one Party disputes the other Party's assertion of non-compliance, that Party should notify the other Party in writing of the basis for its assertion of compliance. If the receiving Party fails to provide the other Party with notice that appropriate corrective measures have been taken within a reasonable time or provide the other Party with proof sufficient to persuade the other Party that it erred in asserting the non-compliance, the requesting Party should proceed pursuant to the Dispute Resolution provisions set forth in the General Terms and Conditions and the Parties should cooperatively seek expedited resolution of the dispute. "Self help", in the form of suspension of access to ordering systems and discontinuance of service, is inappropriate and coercive. Moreover, it effectively denies one Party the ability to avail itself to the Dispute Resolution process otherwise agreed to by the Parties.

**BELLSOUTH'S POSITION:** (A) The Party receiving such notice should provide documentation within seven (7) business days to prove authorization.

(B) The Party providing notice of such impropriety should provide notice to the offending Party that additional applications for service may be refused, that any pending orders for service may not be completed, and/or that access to ordering systems may be suspended if such use is not corrected or ceased by the fifth (5<sup>th</sup>) calendar day following the date of the notice. In addition, the alleging Party may, at the same time, provide written notice to the person(s) designated by the other Party to receive notices of noncompliance that the alleging Party may terminate the provision of access to ordering systems to the other Party and may discontinue the provisioning of existing services if such use is not corrected or ceased by the tenth (10<sup>th</sup>) calendar day following the date of the initial notice. If the other Party disagrees with the alleging Party's allegations of unauthorized use, the other Party shall proceed pursuant to the dispute resolution provisions set forth in the General Terms and Conditions.

*Issue No. 6-4 [Section 2.6]: Should BellSouth be allowed to assess manual service order charges on CLEC orders for which BellSouth does not provide an electronic ordering option?*

**CLECs' POSITION:** NO, if, at any time, electronic interfaces are not available to make placement of an electronic LSR possible, CLEC must use the manual LSR process for the ordering of UNEs and Combinations. In such cases where CLEC does not willfully choose to use the manual LSR process, CLEC should be assessed the lower electronic LSR OSS rate.

**BELLSOUTH'S POSITION:** YES, BellSouth is not required to provide electronic ordering capability for every function. BellSouth has implemented the Change Control Process for CLEC requests to change BellSouth's OSS capabilities if CLEC is not satisfied with existing ordering capabilities.

*Issue No. 6-5 [Section 2.6.5]: What rate should apply for Service Data Advancement (a/k/a service expedites)?*

**CLECs' POSITION:** Rates for Service Date Advancement (a/k/a service expedites) related to UNEs, interconnection or collocation should be set consistent with TELRIC pricing principles.

**BELLSOUTH'S POSITION:** BellSouth is not required to provide expedited service pursuant to The Act. If BellSouth elects to offer expedite capability as an enhancement to a CLEC, BellSouth's tariffed rates for service date advancement should apply.

*Issue No. 6-6 [Section 2.6.25]: Should CLEC be required to deliver a FOC to BellSouth for purposes of porting a number within a firm interval?*

**CLECs' POSITION:** NO, CLEC is not required by law to commit to specific intervals, and does not have the necessary automated system in place to meet such requirements. Moreover, BellSouth refuses to commit to deliver FOCs within a firm interval. CLEC, however, subject to the same exclusions that apply to BellSouth's delivery of a FOC, is willing to commit to use best efforts to return a FOC to BellSouth, for purposes of porting a number, within an average of 5 business days, for noncomplex orders, after CLEC's receipt from BellSouth of a valid LSR.

**BELLSOUTH'S POSITION:** YES, BellSouth is required to provide FOCs to CLEC in intervals prescribed by this Commission, which if not met require BellSouth to remit SEEMs penalties. If CLEC is not held to the same standard, the End User customer is impaired by being unable to receive the same service interval from all Local service providers.

*Issue No. 6-7 [Section 2.6.26]: Should CLEC be required to provide Reject Responses to BellSouth within a firm interval?*

**CLECs' POSITION:** NO, CLEC is not required by law to commit to specific intervals, and does not have the necessary automated system in place to meet such requirements. Moreover,



BellSouth refuses to commit to deliver Reject Responses within a firm interval. CLEC, however, subject to the same exclusions that apply to BellSouth's delivery of Reject Responses, is willing to commit to use best efforts to return Reject Responses to BellSouth, for purposes of porting a number, within an average of 5 business days, for noncomplex orders, after CLEC's receipt from BellSouth of a valid LSR.

**BELLSOUTH'S POSITION:** YES, BellSouth is required to provide FOC Reject Responses to CLEC in intervals prescribed by this Commission which if not met require BellSouth to remit SEEMs penalties. If CLEC is not held to the same standard, the End User customer is impaired by being unable to receive the same service interval from all local service providers.

*Issue No. 6-8 [Section 2.7.10.4]: Should BellSouth be required to provide performance and maintenance history for circuits with chronic problems?*

**CLECS' POSITION:** YES, upon request from CLEC, BellSouth should disclose all available performance and maintenance history regarding the network element, service or facility subject to the chronic trouble ticket.

**BELLSOUTH'S POSITION:** NO, network performance and maintenance history is BellSouth's proprietary information.

*Issue No. 6-9 [Section 2.9.1]: Should charges for substantially similar OSS functions performed by the parties be reciprocal?*

**CLECS' POSITION:** YES, the Parties should bill each other OSS rates pursuant to the terms, conditions and rates for OSS as set forth in Exhibit A of Attachment 2 of the Agreement, for substantially similar OSS functions performed by the Parties.

**BELLSOUTH'S POSITION:** YES, but only for those functions that CLEC performs that are substantially similar to those performed by BellSouth and only if the CLEC performs the same OSS functions pursuant to the terms and conditions under which BellSouth bills CLEC for OSS, including FOC turnaround times the same as BellSouth's, due date intervals the same as BellSouth's and CSRs handled under the same terms and conditions under which BellSouth provides the CSRs to CLEC.

*Issue No. 6-10 [Section 3.1.1]: (A) Can Bellsouth make the porting of an End User to the CLEC contingent on either the CLEC having an operating, billing and/or collection arrangement with any third party carrier, including BellSouth Long Distance or the End User changing its PIC? (B) If not, should BellSouth be subject to liquidated damages for imposing such conditions?*

**CLECs' POSITION:** (A) NO, BellSouth is required by law to port a customer once the customer requests to be switched to another local service provider, regardless of any arrangement or agreement (or lack thereof) between CLEC and BellSouth Long Distance or another third party carrier. BellSouth's practice represents an anticompetitive leveraging of its ILEC status in favor of, and in collusion with, its Section 272 affiliate. More specifically, BellSouth may not condition its compliance with these obligations under the Agreement upon CLEC's or its End-Users' entry into any billing and/or collection arrangement, operational understanding, relationship or other arrangement with one or more of BellSouth's Affiliates, and/or any third party carrier.

(B) YES, liquidated damages are appropriate in this instance because it would be impossible or commercially impracticable to ascertain and fix the actual amount of damages as would be sustained by CLEC as a result of such action by BellSouth. A liquidated damage amount of \$1,000 per occurrence per day is a reasonable approximation of the damages likely to

be sustained by CLEC, upon the occurrence and during the continuance of any such breach. Liquidated damages should be in addition to and without prejudice to or limitation upon any other rights or remedies CLEC and/or any of its End Users may have under this Agreement and/or other applicable documents against BellSouth.

**BELLSOUTH'S POSITION:** (A) YES. If another carrier restricts the conditions under which that carrier's end user can retain a PIC, CLEC should be required to either comply with that carrier's requirements or transfer the end-user with another PIC. (B) NO, liquidated damages provisions are inappropriate.

*Issue No. 6-11 [Sections 3.1.2, 3.1.2.1]: (A) Should the mass migration of customer service arrangements resulting from mergers, acquisitions and asset transfers be accomplished by the submission of an electronic LSR or spreadsheet*

*(B) If so, what rates should apply?*

*(C) What should be the interval for such mass migrations of services?*

**CLECs' POSITION:** (A) YES, mass migration of customer service arrangements (e.g., UNEs, Combinations, resale) should be accomplished pursuant to submission of electronic LSR or, if mutually agreed to by the Parties, by submission of a spreadsheet in a mutually agreed-upon format. Until such time as an electronic LSR process is available, a spreadsheet containing all relevant information should be used.

(B) An electronic OSS charge should be assessed per service arrangement migrated. In addition, BellSouth should only charge CLEC a TELRIC-based records change charge, as set forth in Exhibit A of Attachment 2, for migrations of customers for which no physical re-termination of circuits must be performed. Similarly, BellSouth should only charge

CLEC a TELRIC-based charge, as set forth in Exhibit A of Attachment 2, for migrations of customers for which physical re-termination of circuits is required.

(C) Migrations should be completed within ten (10) calendar days of an LSR or spreadsheet submission.

**BELLSOUTH’S POSITION:** (A) No, each and every Merger, Acquisition and Asset Transfer is unique and requires project management and planning to ascertain the appropriate manner in which to accomplish the transfer, including how orders should be submitted. The vast array of services that may be the subject of such a transfer, under the agreement and both state and federal tariffs, necessitates that various forms of documentation may be required.

(B) The rates by necessity must be negotiated between the Parties based upon the particular services to be transferred and the work involved.

(C) No finite interval can be set to cover all potential situations. While shorter intervals can be committed to and met for small, simple projects, larger and more complex projects require much longer intervals and prioritization and cooperation between the Parties.

### **BILLING (ATTACHMENT 7)**

*Issue No. 7-1 [Section 1.1.3]: Should there be a time limit on the parties’ ability to engage in backbilling?*

**CLECs’ POSITION:** YES, bills for service should not be rendered more than ninety (90) calendar days have passed since the bill date on which those charges ordinarily would have been billed. Billed amounts for services rendered more than one (1) billing period prior to the Bill Date should be invalid unless the billing Party identifies such billing as “back-billing” on a line-item basis. Billing beyond (90) calendar days and up to a limit of six (6) months after the date upon which the bill ordinarily would have been issued may be allowed under the following

conditions: (1) charges connected with jointly provided services whereby meet point billing guidelines require either Party to rely on records provided by a third party and such records have not been provided in a timely manner; and (2) charges incorrectly billed due to erroneous information supplied by the non-billing Party.

**BELLSOUTH’S POSITION:** BellSouth will provide its position with its Response.

*Issue No. 7-2 [Section 1.2.2]: (A) What charges, if any, should be imposed for records changes made by the Parties to reflect changes in corporate names or other LEC identifiers such as OCN, CC, CIC and ACNA? (B) What intervals should apply to such changes?*

**CLECs’ POSITION:** (A) A Party should be entitled to make one (1) “LEC Change” (i.e., corporate name change, OCN, CC, CIC, ACNA change) per state in any twelve (12) month period without charge by the other Party for updating its databases, systems and records solely to reflect such change. For any additional LEC Changes, TELRIC compliant rates should be charged.

(B) “LEC Changes” should be accomplished in thirty (30) calendar days and should result in no delay or suspension of ordering or provisioning of any element or service provided pursuant to this Agreement, or access to any pre-order, order, provisioning, maintenance or repair interfaces. At the request of a Party, the other Party should establish a new BAN within ten (10) calendar days.

**BELLSOUTH’S POSITION:** BellSouth will provide its position with its Response.

*Issue No. 7-3 [Section 1.4]: When should payment of charges for service be due?*

**CLECs’ POSITION:** Payment of charges for services rendered should be due thirty (30) calendar days from receipt or website posting of a complete and fully readable bill or within thirty (30)

calendar days from receipt or website posting of a corrected or retransmitted bill in those cases where correction or retransmission is necessary for processing.

**BELLSOUTH’S POSITION:** Payment for services should be due on or before the next bill date (Payment Due Date) in immediately available funds.

*Issue No. 7-4 [Section 1.6]: (A) What interest rate should apply for late payments? (B) What fee should be assessed for returned checks?*

**CLECs’ POSITION:** (A) The interest rate that should apply for late payments is a uniform region-wide (1) percent per month. (B) In addition to any applicable late payment charges, a uniform region-wide \$20 fee for all returned checks should apply.

**BELLSOUTH’S POSITION:** (A) The applicable interest rate approved by each state Commission in BellSouth’s tariffs should apply. (B) The Commission approved rate from the GSST should apply or, in the absence of such, the amount permitted by state law.

*Issue No. 7-5 [Section 1.7.1]: What recourse should a Party have if it believes the other Party is engaging in prohibited, unlawful or improper use of its facilities or services, abuse of the facilities or noncompliance with the Agreement or applicable tariffs?*

**CLECs’ POSITION:** Each Party should have the right to suspend access to ordering systems for and to terminate particular services or access to facilities that are being used in an unlawful, improper or abusive manner. However, such remedial action should be limited to the services or facilities in question and such suspension or termination should not be imposed unilaterally by one Party over the other’s written objections to or denial of such accusations. In the event of such a dispute, “self help” should not supplant the Dispute Resolution process set forth in the Agreement.

**BELLSOUTH’S POSITION:** Each Party should have the right to suspend or terminate service in the event it believes the other party is engaging in one of these practices.

*Issue No. 7-6 [Section 1.7.2]: Should CLEC be required to calculate and pay past due amounts in addition to those specified in BellSouth’s notice of suspension or termination for nonpayment in order to avoid suspension or termination?*

**CLECs’ POSITION:** NO. If CLEC receives a notice of suspension or termination from BellSouth with a limited time to pay undisputed past due amounts, CLEC should, in order to avoid suspension or termination, be required to pay only the amount past due as of the date of the notice and as expressly and plainly indicated on the notice. Otherwise, CLEC will risk suspension or termination due to possible calculation and timing errors.

**BELLSOUTH’S POSITION:** BellSouth will provide its position with its Response.

*Issue No. 7-7 [Section 1.8.3]: How many months of billing should be used to determine the maximum amount of the deposit?*

**CLECs’ POSITION:** The amount of a deposit should not exceed two month’s estimated billing for new CLECs or one and one-half month’s actual billing for existing CLECs (based on average monthly billings for the most recent six (6) month period). The one and one-half month’s actual billing deposit limit for existing CLECs is reasonable given that balances can be predicted with reasonable accuracy and that significant portions of services are billed in advance.

**BELLSOUTH’S POSITION:** The average of two (2) months of actual billing for existing customers or estimated billing for new customers, which is consistent with the telecommunications industry’s standard and BellSouth’s practice with its end users.

*Issue No. 7-8 [Section 1.8.3.1]: Should the amount of the deposit BellSouth requires from CLEC be reduced by past due amounts owed by BellSouth to CLEC?*

**CLECS' POSITION:** YES, the amount of security due from an existing CLEC should be reduced by amounts due CLEC by BellSouth aged over thirty (30) calendar days. BellSouth may request additional security in an amount equal to such reduction once BellSouth demonstrates a good payment history, as defined in the deposit provisions of Attachment 7. This provision is appropriate given that the Agreement's deposit provisions are not reciprocal and that BellSouth's payment history with CLECs is often poor.

**BELLSOUTH'S POSITION:** NO, CLEC's remedy for addressing late payment by BellSouth should be suspension/termination of service or application of interest/late payment charges similar to BellSouth's remedy for addressing late payment by CLEC.

*Issue No. 7-9 [Section 1.8.6]: Should BellSouth be entitled to terminate service to CLEC pursuant to the process for termination due to non-payment if CLEC refuses to remit any deposit required by BellSouth within 30 calendar days?*

**CLECS' POSITION:** NO, BellSouth should have a right to terminate services to CLEC for failure to remit a deposit requested by BellSouth only in cases where (a) CLEC agrees that such a deposit is required by the Agreement, or (b) the Commission has ordered payment of such deposit. A dispute over a requested deposit should be addressed via the Agreement's Dispute Resolution provisions and not through "self-help".

**BELLSOUTH'S POSITION:** YES, thirty (30) calendar days is a commercially reasonable time period within which CLEC should have met its fiscal responsibilities.



*Issue No. 7-10 [Section 1.8.7]: What recourse should be available to either Party when the Parties are unable to agree on the need for or amount of a reasonable deposit?*

**CLECs' POSITION:** If the Parties are unable to agree on the need for or amount of a reasonable deposit, either Party should be able to file a petition for resolution of the dispute and both parties should cooperatively seek expedited resolution of such dispute.

**BELLSOUTH'S POSITION:** If CLEC does not agree with the amount or need for a deposit requested by BellSouth, CLEC may file a petition with the Commission for resolution of the dispute and BellSouth would cooperatively seek expedited resolution of such dispute. BellSouth shall not terminate service during the pendency of such a proceeding provided that CLEC posts a payment bond for the amount of the requested deposit during the pendency of the proceeding.

*Issue No. 7-11 [Section 1.8.9]: Under what conditions may BellSouth seek additional security deposit from CLEC?*

**CLECs' POSITION:** Subject to a standard of commercial reasonableness and the standards for deposits requirements set forth in Attachment 7, BellSouth may seek an additional deposit if a material change in the circumstances of CLEC so warrants and/or gross monthly billing has increased more than 25% beyond the level most recently used to determine the level of deposit. BellSouth should not be entitled to make such additional requests based solely on increased billing more frequently than once in any six (6) month period.

**BELLSOUTH'S POSITION:** BellSouth may seek additional security, subject to a standard of commercial reasonableness, if a material change in the circumstances of CLEC so warrants and/or gross monthly billing has increased beyond the level most recently used to determine the level of security deposit.

*Issue No. 7-12 [Section 1.9.1]: To whom should BellSouth be required to send notice of suspension for additional applications for service, pending applications for service and access to BellSouth's ordering systems?*

**CLECS' POSITION:** Notice of suspension for additional applications for service, pending applications for service, and access to BellSouth's ordering systems should be sent pursuant to the requirements of Attachment 7 and also should be sent via certified mail to the individual(s) listed in the Notices provision of the General Terms and Conditions.

**BELLSOUTH'S POSITION:** BellSouth will provide its position with its Response.

**BONA FIDE REQUEST/NEW BUSINESS REQUEST (BFR/NBR)**  
**(ATTACHMENT 11)**

*Issue No. 11-1 [Sections 1.5, 1.8.1, 1.9, 1.10]: (A) Should BellSouth be permitted to charge CLEC the full development costs associated with a BFR? (B) If so, how should these costs be recovered?*

**CLECS' POSITION:** (A) NO, charges associated with the development of a BFR should be apportioned among CLECs who may benefit from the UNE(s). (B) To the extent BellSouth can charge CLEC for the development costs associated with a BFR, such costs should be assessed through nonrecurring and recurring rates.

**BELLSOUTH'S POSITION:** (A) YES, BellSouth is entitled to recover its costs in provisioning services to CLEC. Since this is a unique request that CLEC is making, CLEC should bear the full development costs. (B) CLEC should be obligated to pay these costs upon request that BellSouth proceed.

## **V. PROCEDURAL MATTERS**

22. Section 252(b)(4)(c) of the Communications Act requires that, unless waived by the parties, the Commission should render a decision in this proceeding not later than nine (9) months after the date on which interconnection negotiations formally commenced which, in this case, is June 6, 2004. In order to allow the most expeditious conduct of this arbitration, the Joint Petitioners respectfully request that the Commission issue a procedural order as promptly as possible, establishing a schedule for discovery requests, prefiled testimony, prehearing conference, and the timing and conduct of the hearing in this matter.

## **VI. CONCLUSION**

23. BellSouth and the Joint Petitioners have, in good faith, attempted to arrive at a mutually acceptable interconnection agreement. While much progress has been made, numerous issues remain unresolved. Accordingly, the Joint Petitioners call upon the Commission to arbitrate the remaining unresolved issues.

WHEREFORE, the Joint Petitioners respectfully request that the Commission resolve the outstanding issues between the parties as set forth in this Joint Petition, resolve each such issue in favor of the Joint Petitioners, grant all the requests sought herein, and grant any other relief as the Commission may deem just and proper.

Respectfully submitted,

By: \_\_\_\_\_  
John E. Selent  
DINSMORE & SHOHL LLP  
1400 PNC Plaza  
500 West Jefferson St.  
Louisville, KY 40202  
Tel. 502-540-2300  
Fax 502-585-2207  
E-mail: [john.selent@dinslaw.com](mailto:john.selent@dinslaw.com)

John J. Heitmann  
Enrico C. Soriano  
Heather T. Hendrickson  
KELLEY DRYE & WARREN LLP  
1200 19th, N.W., Suite 500  
Washington, D.C. 20036  
Tel. (202) 955-9600  
Fax (202) 955-9792

*Counsel for the Joint Petitioners*

Dated: February 11, 2004

**CERTIFICATE OF SERVICE**

I, [NAME], do hereby certify that I have, on this [DATE] day of [DATE] 2004 caused to be served upon the following individuals, by first class U.S. mail, postage prepaid, a copy of the foregoing Joint Petition for Arbitration:

[CUSTOMIZE]

---

# **EXHIBIT 1**

## **MATRIX OF UNRESOLVED ISSUES**

# **EXHIBIT 2**

## **WORKING COPY OF COMPOSITE INTERCONNECTION AGREEMENT**

**AGREEMENT  
GENERAL TERMS AND CONDITIONS**

**(Note - The Parties agree to correct all section references upon finalization of the Agreement.)**

**THIS agreement (Agreement)** is made by and between BellSouth Telecommunications, Inc., (“BellSouth”), a Georgia corporation, and <<customer\_name>> (“<<customer\_short\_name>>”), a \_\_\_\_\_ corporation, and shall be effective on the Effective Date, as defined herein. This Agreement may refer to either BellSouth or <<customer\_short\_name>> or both as a “Party” or “Parties.”

**WITNESSETH**

**WHEREAS**, BellSouth is an incumbent local exchange telecommunications company authorized to provide telecommunications services in the states of Alabama, Florida, Georgia, Kentucky, Louisiana, Mississippi, North Carolina, South Carolina and Tennessee; and

**WHEREAS**, <<customer\_short\_name>> is or seeks to become a CLEC authorized to provide telecommunications services in the states of Alabama, Florida, Georgia, Kentucky, Louisiana, Mississippi, North Carolina, South Carolina, and Tennessee; and

**WHEREAS**, <<customer\_short\_name>> wishes to resell BellSouth’s telecommunications services and purchase network elements and other services, and, primarily in connection therewith, may wish to utilize collocation space as set forth in Attachment 4 of this Agreement); and

**WHEREAS**, the Parties wish to interconnect their facilities and exchange traffic pursuant to and consistent with the rights and obligations set forth in Sections 251 and 252 of the Act.

**NOW THEREFORE**, in consideration of the mutual agreements contained herein, BellSouth and <<customer\_short\_name>> agree as follows:

**1. Definitions**

1.1 The definitions set forth in this Section apply to the Agreement as a whole and both Parties’ conduct thereunder. Additional definitions are included in the various attachments to this Agreement. Unless the context clearly indicates otherwise, any term defined or used in the singular shall include the plural.

1.2 **Affiliate** is defined as a person that (directly or indirectly) owns or controls, is owned or controlled by, or is under common ownership or control with, another person. For purposes of this paragraph, the term “own” means to own an equity interest (or equivalent thereof) of more than 10 percent.



- 1.3 **Commission** is defined as the appropriate regulatory agency in each state of BellSouth's nine-state region (Alabama, Florida, Georgia, Kentucky, Louisiana, Mississippi, North Carolina, South Carolina, and Tennessee).
- 1.4 **Competitive Local Exchange Carrier (CLEC)** means a telephone company certified by the Commission to provide local exchange service within BellSouth's franchised area.
- 1.5 **Day** is defined to mean calendar day, unless otherwise expressly noted.
- 1.6 [Parties Disagree]
- [<<customer\_short\_name>> Version] **Effective Date** is defined as the date that the Agreement is effective and shall be ten (10) calendar days after the date of the last signature executing the Agreement. Non rate impacting future amendments will be effective as of the date of the last signature executing the amendment or as otherwise ordered in a FCC or Commission order or rule. Future amendments incorporating Commission-approved rates will be effective **as of the effective date of the Commission order, if an amendment is requested within thirty (30) calendar days of that date. Otherwise, such amendments shall be effective ten (10) calendar days after request.**
- [BellSouth Version] **Effective Date** is defined as the date that the Agreement is effective and shall be ten (10) calendar days after the date of the last signature executing the Agreement. Non rate impacting future amendments will be effective as of the date of the last signature executing the amendment or as otherwise ordered in a FCC or Commission order or rule. Future amendments incorporating Commission-approved rates will be effective **ten (10) calendar days after the date of the last signature executing the amendment.**
- 1.7 [Parties Disagree]
- [<<customer\_short\_name>> Version] **End User** means the **customer of a Party.**
- [BellSouth Version] **End User** means the **ultimate user of the Telecommunications Service.**
- 1.8 **FCC** means the Federal Communications Commission.
- 1.9 **General Terms and Conditions** means this document including all of the terms, provisions and conditions set forth herein.
- 1.10 **National Holiday** means New Year's Day, Martin Luther King Jr. Day, President's Day/Washington's Birthday, Memorial Day, Independence Day, Labor Day, Columbus Day, Veterans' Day, Thanksgiving Day, Christmas Day. In the calculation of intervals of less than ten (10) calendar days national holidays will be excluded.

- 1.11 **Project Management** means the BellSouth Professional Services organization.
- 1.12 **Telecommunications** means the transmission, between or among points specified by the user, of information of the user's choosing, without change in the form or content of the information as sent and received.
- 1.13 **Telecommunications Service** means the offering of telecommunications for a fee directly to the public, or to such classes of users as to be effectively available directly to the public, regardless of the facilities used.
- 1.14 **Telecommunications Act of 1996 ("1996 Act")** means Public Law 104-104 of the United States Congress effective February 8, 1996. The 1996 Act is part of the Communications Act of 1934 (47 U.S.C. Section 1 et. seq.) as amended ("the Act").
2. **CLEC Certification**
- 2.1 Prior to execution of this Agreement, BellSouth may request and <<customer\_short\_name>> agrees to provide BellSouth in writing <<customer\_short\_name>>'s CLEC certification for all states covered by this Agreement except Kentucky. BellSouth will file this Agreement with the appropriate Commission for approval.
- 2.2 To the extent <<customer\_short\_name>> is not certified as a CLEC in each state covered by this Agreement as of the execution hereof, <<customer\_short\_name>> will notify BellSouth in writing and provide CLEC certification when it becomes certified to operate in any other state covered by this Agreement. Upon notification, BellSouth will file this Agreement with the appropriate Commission for approval.
3. **Term of the Agreement**
- 3.1 The term of this Agreement shall be three and one half (3 ½) years, beginning on the Effective Date and shall apply to the BellSouth territory in the state(s) of Alabama, Florida, Georgia, Kentucky, Louisiana, Mississippi, North Carolina, South Carolina and Tennessee. Notwithstanding any prior agreement of the Parties, the rates, terms and conditions of this Agreement shall not be applied retroactively prior to the Effective Date.
- 3.2 The Parties agree that by no earlier than two hundred seventy (270) calendar days and no later than one hundred and eighty (180) calendar days prior to the expiration of this Agreement, they shall commence negotiations for a new agreement for a new agreement to be effective beginning on the expiration date of this Agreement ("Subsequent Agreement").
- 3.3 If, within one hundred and thirty-five (135) calendar days of the designated start date of the negotiation referred to in Section 3.2, above, the Parties are unable to satisfactorily negotiate new terms, conditions and prices for a Subsequent

Agreement, either Party may petition the Commission to establish appropriate terms, conditions and prices pursuant to 47 U.S.C. 252. The Parties agree that, in such event, they shall encourage the Commission to issue its order regarding the Subsequent Agreement no later than the expiration date of this Agreement. The Parties further agree that in the event the Commission does not issue its Arbitration order prior to the expiration date of this Agreement, or if the Parties continue beyond the expiration date of this Agreement to negotiate the Subsequent Agreement, the Subsequent Agreement ultimately ordered by the Commission, or negotiated by the Parties, will be effective upon the effective date set forth in the Subsequent Agreement.

3.4 Notwithstanding the foregoing and except as set forth in Section 3.4.1 below, in the event that, as of the date of the expiration of this Agreement and conversion of this Agreement to a month-to-month term, the Parties have not entered into a Subsequent Agreement and no arbitration proceeding has been filed in accordance with Section 252 of the Act, then either Party may terminate this Agreement upon sixty (60) calendar days notice to the other Party. In the event that BellSouth terminates this Agreement as provided above, BellSouth shall continue to offer services to <<customer\_short\_name>> pursuant to BellSouth's then current standard interconnection agreement or <<customer\_short\_name>> may exercise its rights under Section 252(i) of the Act. In the event that BellSouth's standard interconnection agreement becomes effective as between the Parties or <<customer\_short\_name>> adopts another agreement, the Parties may continue to negotiate a Subsequent Agreement, and the terms of such Subsequent Agreement shall be effective as of the effective date stated in such Subsequent Agreement.

3.4.1 If an arbitration proceeding has been filed in accordance with Section 252 of the Act and if the Commission does not issue its order prior to the expiration of this Agreement, this Agreement shall be deemed extended on a month-to-month basis until the Subsequent Agreement becomes effective. The terms of such Subsequent Agreement shall be effective as of the effective date stated in such Subsequent Agreement and shall not be applied retroactively to the expiration date of this Agreement unless the Parties agree otherwise. Neither Party shall refuse to provide services to the other Party during the negotiation of the Subsequent Agreement or the transition from this Agreement to the Subsequent Agreement.

#### 4. **Termination**

4.1 <<customer\_short\_name>> may terminate any network element, interconnection or other services provided under this Agreement upon thirty (30) calendar days written notice to BellSouth. In such cases, <<customer\_short\_name>>'s obligation to pay for such network element, interconnection or other services shall be limited to the amounts due provided up to and including the date of termination.

4.2 Upon notice of termination, the Parties agree to cooperate in an orderly and efficient transition to <<customer\_short\_name>> or another vendor and to exercise their best efforts to effect an orderly and efficient transition.

5. **Operational Support Systems**

5.1 <<customer\_short\_name>> shall pay charges for Operational Support Systems (OSS) as set forth in this Agreement in Attachment 1 and/or in Attachments 2, 3 and 5, as applicable.

6. **Parity**

6.1 When <<customer\_short\_name>> purchases services from BellSouth pursuant to Attachment 1 of this Agreement for the purposes of Resale to its End Users, such services shall be at least equal in quality, subject to the same conditions, and provided within the same provisioning time intervals that BellSouth provides to its Affiliates, subsidiaries and End Users. To the extent technically feasible, the quality of a Network Element, as well as the quality of the access to such Network Element provided by BellSouth to <<customer\_short\_name>> shall be at least equal in quality to that which BellSouth provides to itself, its Affiliates or any other Telecommunications carrier. The quality of the interconnection between the network of BellSouth and the network of <<customer\_short\_name>> shall be at a level that is at least equal to that which BellSouth provides itself, a subsidiary, an Affiliate, or any other party. The interconnection facilities shall be designed to meet the same technical criteria and service standards that are used within BellSouth's network and shall extend to a consideration of service quality as perceived by BellSouth's End Users and service quality as perceived by <<customer\_short\_name>> and its End Users.

7. **White Pages Directory Listings Requirements**

7.1 Listings. <<customer\_short\_name>> shall provide all new, changed and deleted listings on a timely basis and BellSouth or its agent will include <<customer\_short\_name>> residential and business customer listings in the appropriate White Pages (residential and business) or alphabetical directories in the geographic areas covered by this Interconnection Agreement in a nondiscriminatory manner and at parity. Directory listings will make no distinction between <<customer\_short\_name>> and BellSouth subscribers.

7.1.1 Rates. So long as <<customer\_short\_name>> provides subscriber listing information (SLI) to BellSouth in accordance with Section 7.2 below, BellSouth shall provide to <<customer\_short\_name>> one (1) primary White Pages listing per <<customer\_short\_name>> subscriber at no charge for the initial listing. Additions or changes to the initial subscriber White Pages listing shall incur a secondary service charge in accordance with Section A4.2 of BellSouth's GSST.

7.2 Procedures for Submitting <<customer\_short\_name>> SLI are found in The BellSouth Business Rules for Local Ordering located at <http://www.interconnection.bellsouth.com>.

- 7.2.1 <<customer\_short\_name>> authorizes BellSouth to release all <<customer\_short\_name>> SLI provided to BellSouth by <<customer\_short\_name>> to qualifying third parties via either license agreement or BellSouth's Directory Publishers Database Service (DPDS), GSST, Section A38.2, as the same may be amended from time to time. Such <<customer\_short\_name>> SLI shall be intermingled with BellSouth's own customer listings and listings of any other CLEC that has authorized a similar release of SLI.
- 7.2.2 No compensation shall be paid to <<customer\_short\_name>> for BellSouth's receipt of <<customer\_short\_name>> SLI, or for the subsequent release to third parties of such SLI. In addition, to the extent BellSouth incurs costs to modify its systems to enable the release of <<customer\_short\_name>>'s SLI, or costs on an ongoing basis to administer the release of <<customer\_short\_name>>'s SLI, <<customer\_short\_name>> shall pay to BellSouth its proportionate share of the reasonable costs associated therewith. At any time that costs may be incurred to administer the release of <<customer\_short\_name>>'s SLI, <<customer\_short\_name>> will be notified. If <<customer\_short\_name>> does not wish to pay its proportionate share of these reasonable costs, <<customer\_short\_name>> may instruct BellSouth that it does not wish to release its SLI to independent publishers, and <<customer\_short\_name>> shall amend this Agreement accordingly. <<customer\_short\_name>> will be liable for all costs incurred until the effective date of the amendment.
- 7.2.3 Neither BellSouth nor any agent shall be liable for the content or accuracy of any SLI provided by <<customer\_short\_name>> under this Agreement. Except to the extent caused by gross negligence or willfull misconduct by BellSouth, <<customer\_short\_name>> shall indemnify, hold harmless and defend BellSouth and its agents from and against any damages, losses, liabilities, demands, claims, suits, judgments, costs and expenses (including but not limited to reasonable attorneys' fees and expenses) arising from BellSouth's tariff obligations or otherwise and resulting from or arising out of any third party's claim of inaccurate <<customer\_short\_name>> listings or use of the SLI provided pursuant to this Agreement. BellSouth may forward to <<customer\_short\_name>> any complaints received by BellSouth relating to the accuracy or quality of <<customer\_short\_name>> listings.
- 7.2.4 BellSouth agrees to address any issue regarding a directory listing raised by a <<customer\_short\_name>> End User in the same manner that BellSouth does for BellSouth's Retail End Users.
- 7.2.5 Listings and subsequent updates will be released consistent with BellSouth system changes and/or update scheduling requirements.
- 7.3 Unlisted/Non-Published Subscribers. <<customer\_short\_name>> will be required to provide to BellSouth the names, addresses and telephone numbers of all <<customer\_short\_name>> customers who wish to be omitted from directories.

- 7.4 Inclusion of <<customer\_short\_name>> End Users in Directory Assistance Database. BellSouth will include and maintain <<customer\_short\_name>> subscriber listings in BellSouth's Directory Assistance databases at no recurring charge and <<customer\_short\_name>> shall provide such Directory Assistance listings to BellSouth at no recurring charge.
- 7.5 Listing Information Confidentiality. BellSouth will afford <<customer\_short\_name>>'s directory listing information the same level of confidentiality that BellSouth affords its own directory listing information.
- 7.6 Additional, Designer, Non-Listed and Non-Published Listings. BellSouth shall provide Additional, Designer, Non-Listed and Non-Published White Pages Listings to <<customer\_short\_name>>'s End Users under the same rates, terms and conditions as BellSouth makes such listings available to its own End Users. Where BellSouth charges its End Users for Additional, Designer, Non-Listed and Non-Published White Pages Listings, BellSouth shall publish such listings under the same rates, terms and conditions to <<customer\_short\_name>> for its Resale End Users subject to the applicable wholesale rates in Attachment 1.
- 7.7 Directories. BellSouth or its agent shall make available White Pages directories to <<customer\_short\_name>> subscribers at no charge or as specified in a separate agreement with BellSouth's agent.
- 7.7.1 Delivery. BellSouth or its agent shall deliver White Pages directories to <<customer\_short\_name>> End Users at parity with BellSouth's delivery of directories to its own End Users.
8. **Local Dialing Parity**
- 8.1 BellSouth shall provide local dialing parity as described in the Act and required by FCC rules, regulations and policies. <<customer\_short\_name>> End Users shall not have to dial any greater number of digits than BellSouth End Users to complete the same call. In addition, <<customer\_short\_name>> End Users shall experience at least the same service quality as BellSouth End Users in terms of post-dial delay, call completion rate and transmission quality.
9. **Court Ordered Requests for Call Detail Records and Other Subscriber Information**
- 9.1 Subpoenas Directed to BellSouth. Where BellSouth provides resold services or local switching for <<customer\_short\_name>>, BellSouth shall respond to subpoenas and court ordered requests delivered directly to BellSouth for the purpose of providing call detail records when the targeted telephone numbers belong to <<customer\_short\_name>> End Users. Billing for such requests will be generated by BellSouth and directed to the law enforcement agency initiating the request. BellSouth shall maintain such information for <<customer\_short\_name>> End Users for the same length of time it maintains such information for its own End Users.

9.2 Subpoenas Directed to <<customer\_short\_name>>. Where BellSouth is providing to <<customer\_short\_name>> Telecommunications Services for resale or providing to <<customer\_short\_name>> the local switching function, then <<customer\_short\_name>> agrees that in those cases where <<customer\_short\_name>> receives subpoenas or court ordered requests regarding targeted telephone numbers belonging to <<customer\_short\_name>> End Users, and where <<customer\_short\_name>> does not have the requested information, <<customer\_short\_name>> will advise the law enforcement agency initiating the request to redirect the subpoena or court ordered request to BellSouth for handling in accordance with 9.1 above.

9.3 In all other instances, where either Party receives a request for information involving the other Party's End User, the Party receiving the request will advise the law enforcement agency initiating the request to redirect such request to the other Party.

## 10. **Liability and Indemnification**

10.1 <<customer\_short\_name>> Liability. In the event that <<customer\_short\_name>> consists of two (2) or more separate entities as set forth in this Agreement and/or any Amendments hereto, all such entities that are Parties to this Agreement shall be jointly and severally liable for the obligations of <<customer\_short\_name>> under this Agreement.

10.2 [Parties Disagree]

[<<customer\_short\_name Version>>] **BellSouth shall take financial responsibility for its own actions in causing or contributing to unbillable or uncollectible <<customer\_short\_name>> revenue.**

[BellSouth Version] **No Section.**

10.3 Liability for Acts or Omissions of Third Parties. The Parties shall not be liable to each other for any act or omission of another Telecommunications company.

10.4 Limitation of Liability

10.4.1 [Parties Disagree]

[<<customer\_short\_name>> Version] **Except for any indemnification obligations of the Parties hereunder, with respect to any claim or suit, whether based in contract, tort or any other theory of legal liability, by either Party, any End User of either Party, or by any other person or entity, for damages associated with any of the services provided pursuant to or in connection with this Agreement, including but not limited to the installation, provision, preemption, termination, maintenance, repair or restoration of service, and, in any event, subject to the provisions of the remainder of this Section, each Party's liability shall be limited to and shall not exceed in aggregate amount over the entire term hereof an amount equal to seven-and-one half percent**

(7.5%) of the aggregate fees, charges or other amounts paid or payable to such Party for any and all services provided or to be provided by such Party pursuant to this Agreement as of the Day immediately preceding the date of assertion or filing of the applicable claim or suit; provided that the foregoing provisions shall not be deemed or construed as (A) imposing or allowing for any liability of either Party for (x) indirect, special or consequential damages as otherwise excluded pursuant to Section 10.4.4 below or (y) any other amount or nature of damages to the extent resulting directly and proximately from the claiming Party's failure to act at all relevant times in a commercially reasonable manner in compliance with such Party's duties of mitigation with respect to all applicable damages or (B) limiting either Party's right to recover appropriate refund(s) of or rebate(s) or credit(s) for fees, charges or other amounts paid at Agreement rates for services not performed or provided or otherwise failing to comply (with applicable refund, rebate or credit amounts measured by the diminution in value of services reasonably resulting from such noncompliance) with the applicable terms and conditions of this Agreement. Notwithstanding the foregoing, claims or suits for damages by either Party, any End User of either Party, or by any other person or entity, to the extent resulting from the gross negligence or willful misconduct of the other Party, shall not be subject to the foregoing limitation of liability.

[BellSouth Version] Except for any indemnification obligations of the Parties hereunder, and except in cases of the provisioning Party's gross negligence or willful misconduct, each Party's liability to the other for any loss, cost, claim, injury, liability or expense, including reasonable attorneys' fees relating to or arising out of any negligent act or omission in its performance of this Agreement, whether in contract or in tort, shall be limited to a credit for the actual cost of the services or functions not performed or improperly performed.

10.4.2

[Parties Disagree]

[<<customer\_short\_name>> Version] No Section.

[BellSouth Version] Limitations in Tariffs. A Party may, in its sole discretion, provide in its tariffs and contracts with its End Users and third parties that relate to any service, product or function provided or contemplated under this Agreement, that to the maximum extent permitted by Applicable Law, such Party shall not be liable to the End User or third party for (i) any loss relating to or arising out of this Agreement, whether in contract, tort or otherwise, that exceeds the amount such Party would have charged that applicable person for the service, product or function that gave rise to such loss and (ii) consequential damages. To the extent that a Party elects not to place in its tariffs or contracts such limitations of liability, and the other Party incurs a loss as a result thereof, such Party shall indemnify and reimburse the other Party for that portion of the loss that would have been



**limited had the first Party included in its tariffs and contracts the limitations of liability that such other Party included in its own tariffs at the time of such loss.**

10.4.3 Neither BellSouth nor <<customer\_short\_name>> shall be liable for physical damage to the other Party's premises, facilities and equipment or End User premises resulting from the furnishing of a service, including, but not limited to, the installation and removal of equipment or associated wiring, except to the extent caused by a Party's negligence, gross negligence or willful misconduct or by a Party's failure to ground properly a local loop after disconnection.

10.4.4 [Parties Disagree]

[<<customer\_short\_name>> Version] Nothing in this Section 10 shall limit a Party's obligation to indemnify or hold harmless the other Party set forth elsewhere in this Agreement. Except in cases of gross negligence or willful or intentional misconduct, under no circumstance shall a Party be responsible or liable for indirect, incidental, or consequential damages **provided that neither the foregoing nor any other provision of this Section 10 shall be deemed or construed as imposing any limitation on the liability of a Party for claims or suits for damages incurred by End Users of the other Party or by such other Party vis-à-vis its End Users to the extent such damages result directly and in a reasonably foreseeable manner from the first Party's performance of services hereunder and were not and are not directly and proximately caused by or the result of such Party's failure to act at all relevant times in a commercially reasonable manner in compliance with such Party's duties of mitigation with respect to such damage.** In connection with this limitation of liability, each Party recognizes that the other Party may, from time to time, provide advice, make recommendations, or supply other analyses related to the services or facilities described in this Agreement, and, while each Party shall use diligent efforts in this regard, the Parties acknowledge and agree that this limitation of liability shall apply to provision of such advice, recommendations, and analyses.

[BellSouth Version] Nothing in this Section 10 shall limit a Party's obligation to indemnify or hold harmless the other Party set forth elsewhere in this Agreement. Except in cases of gross negligence or willful or intentional misconduct, under no circumstance shall a Party be responsible or liable for indirect, incidental, or consequential damages. In connection with this limitation of liability, each Party recognizes that the other Party may, from time to time, provide advice, make recommendations, or supply other analyses related to the services or facilities described in this Agreement, and, while each Party shall use diligent efforts in this regard, the Parties acknowledge and agree that this limitation of liability shall apply to provision of such advice, recommendations, and analyses.

10.4.5 To the extent any specific provision of this Agreement purports to impose liability, or limitation of liability, on either Party different from or in conflict with the liability or limitation of liability set forth in this Section, then with respect to

the particular facts or circumstances covered by the more specific provision, the liability or limitation of liability contained in such specific provision shall apply. Nothing in this Section shall be interpreted to limit <<customer\_short\_name>>'s rights to remedies and/or claims provided or contemplated elsewhere in this Agreement.

## 10.5

[Parties Disagree]

[<<customer\_short\_name>> Version] Indemnification for Certain Claims. The Party providing services hereunder, its Affiliates and its parent company, shall be indemnified, defended and held harmless by the Party receiving services hereunder against any claim **for libel, slander or invasion of privacy arising from the content of the receiving Party's own communications. The Party receiving services hereunder, its Affiliates and its parent company, shall be indemnified, defended and held harmless by the Party providing services hereunder against any claim, loss or damage to the extent arising from (1) the providing Party's failure to abide by Applicable Law, or (2) injuries or damages arising out of or in connection with this Agreement to the extent caused by the providing Party's negligence, gross negligence or willful misconduct.**

[BellSouth Version] Indemnification for Certain Claims. The Party providing services hereunder, its Affiliates and its parent company, shall be indemnified, defended and held harmless by the Party receiving services hereunder against any claim, **loss or damage arising from the receiving Party's use of the services provided under this Agreement pertaining to (1) claims for libel, slander or invasion of privacy arising from the content of the receiving Party's own communications, or (2) any claim, loss or damage claimed by the End User of the Party receiving services arising from such company's use or reliance on the providing Party's services, actions, duties, or obligations** arising out of this Agreement.

### 10.5.1

Promptly after receipt of notice of the commencement of, or of any definite and colorable written claim or written threat as to the commencement of any action or proceeding relating to a matter or matters for which a Party may seek indemnification pursuant to this Section 10.5.1, such Party (the "Indemnified Party") shall promptly give written notice to the other Party (the "Indemnifying Party") of the action or proceeding so commenced (or claimed or threatened for commencement as aforesaid), whereupon the Indemnifying Party shall, be obligated (unless the Indemnified Party shall have otherwise waived such obligation in its sole and absolute discretion by its written election to maintain its own defense, subject, in such event and in all respects, to the exemptions from and limitations applicable to the Indemnifying Party's liability as provided in the final sentence of this Section 10.5.1) to assume the defense thereof at its sole cost and expense using counsel selected by the Indemnifying Party and reasonably acceptable to the Indemnified Party in its reasonable and good faith business

judgment; provided that, the Parties hereby acknowledge and agree that the failure by an Indemnified Party to notify the Indemnifying Party as to a claim or the commencement (or written claim or threat of commencement) of any action or proceeding as aforesaid shall not relieve the Indemnifying Party of any liability it may have to the Indemnified Party with respect thereto, except and to the extent that the Indemnifying Party shall have actually and demonstrably incurred material prejudice, or suffered forfeiture of material substantive defenses or claims, resulting directly and exclusively from the failure to so notify. From and after assumption by an Indemnifying Party of the defense of any such pending (or claimed or threatened, as above) claim, action or proceeding, the Indemnified Party shall cooperate in a good faith and commercially-reasonable manner with the Indemnifying Party's reasonable requests for assistance or information relating to such action or proceeding, at the Indemnifying Party's sole cost and expense. The Indemnified Party shall retain the right to participate in the investigation and defense of such action or proceeding, with separate counsel chosen and paid for by the Indemnified Party. Unless the Indemnified Party shall have elected in its sole and absolute discretion to waive any further right to be indemnified with respect to any such action, proceeding or claim the Indemnified Party's counsel shall not unreasonably interfere with the defense by the Indemnifying Party and its counsel, and, absent a good faith and commercially reasonable basis therefore, as communicated in writing to the Indemnifying Party in reasonable detail, the Indemnified Party's counsel shall not raise any claims, defenses, or objections or otherwise take a course of action in representation of the Indemnified Party when such course of action would unreasonably conflict with a course of action or inaction chosen by the Indemnifying Party. An Indemnifying Party shall not be liable under this Section 10.5.1 for settlements or compromises by the Indemnified Party of any claim, action or proceeding commenced (or claimed or threatened for commencement as aforesaid) as described in this Section 10.5.1 unless the Indemnifying Party shall have previously consented in writing thereto (such consent not to be unreasonably withheld, conditioned or delayed) or unless the Indemnifying Party has been given notice and reasonable opportunity to defend such claim, action or proceeding and has failed to promptly undertake the defense.

10.6 Disclaimer. EXCEPT AS SPECIFICALLY PROVIDED TO THE CONTRARY IN THIS AGREEMENT INCLUDING ALL ATTACHMENTS AND EXHIBITS HERETO AND ANY APPLICABLE SERVICE QUALITY STANDARDS, MEASURES, ASSURANCES AND ASSOCIATED REMEDIES ORDERED BY THE FCC OR COMMISSION, NEITHER PARTY MAKES ANY REPRESENTATIONS OR WARRANTIES TO THE OTHER PARTY CONCERNING THE SPECIFIC QUALITY OF ANY SERVICES, OR FACILITIES PROVIDED UNDER THIS AGREEMENT. THE PARTIES DISCLAIM, WITHOUT LIMITATION, ANY WARRANTY OR GUARANTEE OF MERCHANTABILITY OR FITNESS FOR A PARTICULAR PURPOSE, ARISING FROM COURSE OF PERFORMANCE, COURSE OF DEALING, OR FROM USAGES OF TRADE.

## 11. Intellectual Property Rights and Indemnification

### 11.1 [Parties Disagree]

[<<customer\_short\_name>> Version] No License. No patent, copyright, trademark or other proprietary right is licensed, granted or otherwise transferred by this Agreement. **A Party's use of the other Party's name, service marks and trademarks shall be in accordance with Applicable Law.**

[BellSouth Version] No License. No patent, copyright, trademark or other proprietary right is licensed, granted or otherwise transferred by this Agreement. **The Parties are strictly prohibited from any use, including but not limited to, in the selling, marketing, promoting or advertising of telecommunications services, of any name, service mark, logo or trademark (collectively, the "Marks") of the Other Party. The Marks include those Marks owned directly by a Party or its Affiliate(s) and those Marks that a Party has a legal and valid license to use. Notwithstanding the foregoing, <<customer\_short\_name>> may make factual references to the BellSouth name as necessary to respond to direct inquiries from customers or potential customers regarding the source of the underlying services or the identity of repair technicians. The Parties acknowledge that they are separate and distinct and that each provides a separate and distinct service and agree that neither Party may, expressly or impliedly, state, advertise or market that it is or offers the same service as the other Party or engage in any other activity that may result in a likelihood of confusion between its own service and the service of the Other Party.**

11.2 Ownership of Intellectual Property. Any intellectual property that originates from or is developed by a Party shall remain the exclusive property of that Party. Except for a limited, non-assignable, non-exclusive, non-transferable license to use patents or copyrights to the extent necessary for the Parties to use any facilities or equipment (including software) or to receive any service solely as provided under this Agreement, no license in patent, copyright, trademark or trade secret, or other proprietary or intellectual property right, now or hereafter owned, controlled or licensable by a Party, is granted to the other Party. Neither shall it be implied nor arise by estoppel. Any trademark, copyright or other proprietary notices appearing on software or documents provided by one Party to the other Party for the receiving Party's internal use, shall not be removed provided that such notices are neither visible to nor detectable by the receiving Party's End Users. It is the responsibility of each Party to ensure at no additional cost to the other Party that it has obtained any necessary licenses in relation to intellectual property of third Parties used in its network that may be required to enable the other Party to use any facilities or equipment (including software), to receive any service, or to perform its respective obligations under this Agreement.

11.3 Indemnification. The Party providing a service pursuant to this Agreement will defend the Party receiving such service or data provided as a result of such

service against claims of infringement arising solely from the use by the receiving Party of such service in the manner contemplated under this Agreement and will indemnify and hold harmless the receiving Party from and against any loss, cost, expense or liability associated with claims.

- 11.4 Claim of Infringement. In the event that use of any facilities or equipment (including software), becomes, or in the reasonable judgment of the Party who owns the affected network is likely to become, the subject of a claim, action, suit, or proceeding based on intellectual property infringement, then said Party shall promptly and at its sole expense:
- 11.4.1 modify or replace the applicable facilities or equipment (including software) while maintaining form and function, or
- 11.4.2 obtain a license sufficient to allow such use to continue, or
- 11.4.3 in the event that the actions contemplated by Section 11.4.1 or 11.4.2 are commercially unreasonable, then said Party may terminate, upon reasonable notice, this contract with respect to use of, or services provided through use of, the affected facilities or equipment (including software), but solely to the extent required to avoid the infringement claim.
- 11.4.4 Neither Party's obligations under this Section shall apply to the extent the infringement is caused by: (i) modification of the facilities or equipment (including software) by the indemnitee; (ii) use by the indemnitee of the facilities or equipment (including software) in combination with equipment or facilities (including software) not provided or authorized by the indemnitor, provided the facilities or equipment (including software) would not be infringing if used alone; (iii) conformance to specifications of the indemnitee which would necessarily result in infringement; or (iv) continued use by the indemnitee of the affected facilities or equipment (including software) after being placed on notice to discontinue use as set forth herein.
- 11.4.5 The foregoing shall constitute the Parties' sole and exclusive remedies and obligations with respect to a third party claim of intellectual property infringement arising out of the conduct of business under this Agreement.
- 11.5 Dispute Resolution. Any claim arising under this Section shall be excluded from the dispute resolution procedures set forth in Section 13 below and shall be brought in a court of competent jurisdiction.

## 12. **Proprietary and Confidential Information**

- 12.1 Proprietary and Confidential Information. It may be necessary for BellSouth and <<customer\_short\_name>>, each as the "Discloser," to provide to the other Party, as "Recipient," certain proprietary and confidential information (including trade secret information) including but not limited to technical, financial, marketing, staffing and business plans and information, strategic information, proposals,

request for proposals, specifications, drawings, maps, prices, costs, costing methodologies, procedures, processes, business systems, software programs, techniques, customer account data, call detail records and like information (collectively the "Information"). All such Information conveyed in writing or other tangible form shall be clearly marked with a confidential or proprietary legend. Information conveyed orally by the Discloser to Recipient shall be designated as proprietary and confidential at the time of such oral conveyance, shall be reduced to writing by the Discloser within forty-five (45) calendar days thereafter, and shall be clearly marked with a confidential or proprietary legend.

- 12.1.1 Each Party shall have the right to correct an inadvertent failure to identify information as Confidential Information by giving written notification within forty-five (45) calendar days after the information is disclosed. The Recipient shall, from that time forward, treat such information as Confidential Information subject to the provisions of this Section 12.
- 12.2 Use and Protection of Information. Recipient agrees to protect such Information of the Discloser provided to Recipient from whatever source from distribution, disclosure or dissemination to anyone except employees of Recipient with a need to know such Information solely in conjunction with Recipient's analysis of the Information and for no other purpose except as authorized herein or as otherwise authorized in writing by the Discloser. Recipient will not make any of any kind of the Information inspected by it. The Recipient will use the same standard of care to protect Information received as they would use to protect their own confidential and proprietary Information. Upon request the Information will be returned by the Recipient to the Discloser within thirty (30) calendar days of completion of any use.
- 12.3 Exceptions. Recipient will not have an obligation to protect any portion of the Information which:
  - 12.3.1 (a) is made publicly available by the Discloser or lawfully by a nonparty to this Agreement; (b) is lawfully obtained by Recipient from any source other than Discloser; (c) is previously known to Recipient without an obligation to keep it confidential; or (d) is released from the terms of this Agreement by Discloser upon written notice to Recipient.
- 12.4 Recipient agrees to use the Information solely for the purposes of negotiations pursuant to 47 U.S.C. 251 or in performing its obligations under this Agreement and for no other entity or purpose, except as may be otherwise agreed to in writing by the Parties. Nothing herein shall prohibit Recipient from providing information requested by the FCC or a state regulatory agency with jurisdiction over this matter, or to support a request for arbitration or an allegation of failure to negotiate in good faith.
- 12.5 Recipient agrees not to publish or use the Information for any advertising, sales or marketing promotions, press releases, or publicity matters that refer either directly

or indirectly to the Information or to the Discloser or any of its affiliated companies.

- 12.6 The disclosure of Information neither grants nor implies any license to the Recipient under any trademark, patent, copyright, application or other intellectual property right that is now or may hereafter be owned by the Discloser.
- 12.7 Survival of Confidentiality Obligations. The Parties' rights and obligations under this Section 12 shall survive and continue in effect until two (2) years after the expiration or termination date of this Agreement with regard to all Information exchanged during the term of this Agreement. Thereafter, the Parties' rights and obligations hereunder survive and continue in effect with respect to any Information that is a trade secret under applicable law.

### 13. **Resolution of Disputes**

#### 13.1 [Parties Disagree]

[<<customer\_short\_name>> Version] Except as otherwise stated in this Agreement, the Parties agree that if any dispute arises as to the interpretation of any provision of this Agreement or as to the proper implementation of this Agreement, either Party may petition the FCC, the Commission **or a court of law** for a resolution of the dispute. Either Party may seek expedited resolution by the Commission, and may request that resolution occur in no event later than sixty (60) calendar days from the date of submission of such dispute. The other Party will not object to such expedited resolution of a dispute. If the FCC or Commission appoints an expert(s) or other facilitator(s) to assist in its decision making, each party shall pay half of the fees and expenses so incurred to the extent the FCC or the Commission requires the Parties to bear such fees and expenses. Each Party reserves any rights it may have to seek judicial review of any ruling made by the FCC, the Commission **or a court of law** concerning this Agreement. Until the dispute is finally resolved, each Party shall continue to perform its obligations under this Agreement, unless the issue as to how or whether there is an obligation to perform is the basis of the dispute, and shall continue to provide all services and payments as prior to the dispute provided however, that neither Party shall be required to act in any unlawful fashion.

[BellSouth Version] Except as otherwise stated in this Agreement, the Parties agree that if any dispute arises as to the interpretation of any provision of this Agreement or as to the proper implementation of this Agreement, either Party may petition the FCC or the Commission for a resolution of the dispute. Either Party may seek expedited resolution by the Commission, and may request that resolution occur in no event later than sixty (60) calendar days from the date of submission of such dispute. The other Party will not object to such expedited resolution of a dispute. If the FCC or Commission appoints an expert(s) or other facilitator(s) to assist in its decision making, each party shall pay half of the fees and expenses so incurred to the extent the FCC or the Commission requires the

Parties to bear such fees and expenses. Each Party reserves any rights it may have to seek judicial review of any ruling made by the FCC or the Commission concerning this Agreement. Until the dispute is finally resolved, each Party shall continue to perform its obligations under this Agreement, unless the issue as to how or whether there is an obligation to perform is the basis of the dispute, and shall continue to provide all services and payments as prior to the dispute provided however, that neither Party shall be required to act in any unlawful fashion.

14. **Taxes**

14.1 Definition. For purposes of this Section, the terms “taxes” and “fees” shall include but not be limited to federal, state or local sales, use, excise, gross receipts or other taxes or tax-like fees of whatever nature and however designated (including tariff surcharges and any fees, charges or other payments, contractual or otherwise, for the use of public streets or rights of way, whether designated as franchise fees or otherwise) imposed, or sought to be imposed, on or with respect to the services furnished hereunder or measured by the charges or payments therefore, excluding any taxes levied on income.

14.2 Taxes and Fees Imposed Directly On Either Providing Party or Purchasing Party.

14.2.1 Taxes and fees imposed on the providing Party, which are not permitted or required to be passed on by the providing Party to its customer, shall be borne and paid by the providing Party.

14.2.2 Taxes and fees imposed on the purchasing Party, which are not required to be collected and/or remitted by the providing Party, shall be borne and paid by the purchasing Party.

14.3 Taxes and Fees Imposed on Purchasing Party But Collected And Remitted By Providing Party.

14.3.1 Taxes and fees imposed on the purchasing Party shall be borne by the purchasing Party, even if the obligation to collect and/or remit such taxes or fees is placed on the providing Party.

14.3.2 To the extent permitted by applicable law, any such taxes and/or fees shall be shown as separate items on applicable billing documents between the Parties. Notwithstanding the foregoing, the purchasing Party shall remain liable for any such taxes and fees regardless of whether they are actually billed by the providing Party at the time that the respective service is billed.

14.3.3 If the purchasing Party determines that in its opinion any such taxes or fees are not payable, the providing Party shall not bill such taxes or fees to the purchasing Party if the purchasing Party provides written certification, reasonably satisfactory to the providing Party, stating that it is exempt or otherwise not subject to the tax or fee, setting forth the basis therefor, and satisfying any other



requirements under applicable law. If any authority seeks to collect any such tax or fee that the purchasing Party has determined and certified not to be payable, or any such tax or fee that was not billed by the providing Party, the purchasing Party may contest the same in good faith, at its own expense. In any such contest, the purchasing Party shall promptly furnish the providing Party with copies of all filings in any proceeding, protest, or legal challenge, all rulings issued in connection therewith, and all correspondence between the purchasing Party and the taxing authority.

- 14.3.4 In the event that all or any portion of an amount sought to be collected must be paid in order to contest the imposition of any such tax or fee, or to avoid the existence of a lien on the assets of the providing Party during the pendency of such contest, the purchasing Party shall be responsible for such payment and shall be entitled to the benefit of any refund or recovery.
- 14.3.5 If it is ultimately determined that any additional amount of such a tax or fee is due to the imposing authority, the purchasing Party shall pay such additional amount, including any interest and penalties thereon.
- 14.3.6 Notwithstanding any provision to the contrary, the purchasing Party shall protect, indemnify and hold harmless (and defend at the purchasing Party's expense) the providing Party from and against any such tax or fee, interest or penalties thereon, or other charges or payable expenses (including reasonable attorney fees) with respect thereto, which are incurred by the providing Party in connection with any claim for or contest of any such tax or fee.
- 14.3.7 Each Party shall notify the other Party in writing of any assessment, proposed assessment or other claim for any additional amount of such a tax or fee by a taxing authority; such notice to be provided, if possible, at least ten (10) calendar days prior to the date by which a response, protest or other appeal must be filed, but in no event later than thirty (30) calendar days after receipt of such assessment, proposed assessment or claim.
- 14.4 Taxes and Fees Imposed on Providing Party But Passed On To Purchasing Party.
- 14.4.1 Taxes and fees imposed on the providing Party, which are permitted or required to be passed on by the providing Party to its customer, shall be borne by the purchasing Party.
- 14.4.2 To the extent permitted by applicable law, any such taxes and/or fees shall be shown as separate items on applicable billing documents between the Parties. Notwithstanding the foregoing, the purchasing Party shall remain liable for any such taxes and fees regardless of whether they are actually billed by the providing Party at the time that the respective service is billed. The Parties agree to use good faith efforts to bill taxes promptly.
- 14.4.3 If the purchasing Party disagrees with the providing Party's determination as to the application or basis for any such tax or fee, the Parties shall consult with

respect to the imposition and billing of such tax or fee. Notwithstanding the foregoing, the providing Party shall retain ultimate responsibility for determining whether and to what extent any such taxes or fees are applicable, and the purchasing Party shall abide by such determination and pay such taxes or fees to the providing Party. The purchasing Party shall retain the right to contest, or to have the providing Party contest on its behalf, the imposition of such taxes and fees; provided however, that any such contest undertaken by or at the request of the purchasing Party shall be at the purchasing Party's expense.

- 14.4.4 In the event that all or any portion of an amount sought to be collected must be paid in order to contest the imposition of any such tax or fee, or to avoid the existence of a lien on the assets of the providing Party during the pendency of such contest, the purchasing Party shall be responsible for such payment and shall be entitled to the benefit of any refund or recovery.
- 14.4.5 If it is ultimately determined that any additional amount of such a tax or fee is due to the imposing authority, the purchasing Party shall pay such additional amount, including any interest and penalties thereon.
- 14.4.6 Notwithstanding any provision to the contrary, the purchasing Party shall protect, indemnify and hold harmless (and defend at the purchasing Party's expense) the providing Party from and against any such tax or fee, interest or penalties thereon, or other reasonable charges or payable expenses (including reasonable attorneys' fees) with respect thereto, which are incurred by the providing Party in connection with any claim for or contest of any such tax or fee.
- 14.4.7 Each Party shall notify the other Party in writing of any assessment, proposed assessment or other claim for any additional amount of such a tax or fee by a taxing authority; such notice to be provided, if possible, at least ten (10) calendar days prior to the date by which a response, protest or other appeal must be filed, but in no event later than thirty (30) calendar days after receipt of such assessment, proposed assessment or claim.
- 14.5 Mutual Cooperation. In any contest of a tax or fee by one Party, the other Party shall cooperate fully by providing records, testimony and such additional information or assistance as may reasonably be necessary to pursue the contest. Further, the other Party shall be reimbursed for any reasonable and necessary out-of-pocket copying and travel expenses incurred in assisting in such contest.

## 15. **Network Maintenance and Management**

- 15.1 The Parties shall work cooperatively to implement this Agreement. The Parties shall exchange appropriate information (e.g., maintenance contact numbers, network information, information required to comply with law enforcement and other security agencies of the Government, etc.) as reasonably required to implement and perform this Agreement.

15.2 Each Party hereto shall design, maintain and operate their respective networks as necessary to ensure that the other Party hereto receives service quality which is consistent with generally accepted industry standards at least at parity with the network service quality given to itself, its Affiliates, its End Users or any other Telecommunications Carrier.

15.3 BellSouth agrees to provide <<customer\_short\_name>> prior notice consistent with applicable FCC rules and the Act of changes in information or technical specifications necessary for the transmission and routing of services using BellSouth's facilities or networks, as well as other changes that affect the interoperability of those respective facilities and networks.

## 16. **Force Majeure**

16.1 In the event performance of this Agreement, or any obligation hereunder, is either directly or indirectly prevented, restricted, or interfered with by reason of fire, flood, earthquake or like acts of God, wars, revolution, civil commotion, explosion, acts of public enemy, embargo, acts of the government in its sovereign capacity, labor difficulties, including without limitation, strikes, slowdowns, picketing, or boycotts, unavailability of equipment from vendor, changes requested by <<customer\_short\_name>>, or any other circumstances beyond the reasonable control and without the fault or negligence of the Party affected, the Party affected, upon giving prompt notice to the other Party, shall be excused from such performance on a day-to-day basis to the extent of such prevention, restriction, or interference (and the other Party shall likewise be excused from performance of its obligations on a day-to-day basis until the delay, restriction or interference has ceased); provided, however, that the Party so affected shall use diligent efforts to avoid or remove such causes of non-performance and both Parties shall proceed whenever such causes are removed or cease.

## 17. **Modification of Agreement**

17.1 BellSouth shall make available, pursuant to 47 USC § 252(i) and the FCC rules and regulations regarding such availability, to <<customer\_short\_name>> any interconnection, service, or network element provided under any other agreement filed and approved pursuant to 47 USC § 252, provided a minimum of six (6) months remains on the term of such agreement. The Parties shall adopt all rates, terms and conditions concerning such interconnection, service or network element and any other rates, terms and conditions that are legitimately related to or were negotiated in exchange for or in conjunction with the interconnection, service or network element being adopted. The adopted interconnection, service, or network element and agreement may be adopted for any BellSouth state, provided it is applicable to that state and provided that <<customer\_short\_name>> may not adopt an interconnection, service, or network element from an agreement that would result in the co-mingling of state specific and regional OSS rates in the same agreement. The term of the adopted agreement or provisions shall expire on the same date as set forth in the agreement that was adopted or from which certain provisions were adopted.

17.2 If <<customer\_short\_name>> changes its name or makes changes to its company structure that affects the identity of <<customer\_short\_name>> due to a merger, acquisition, transfer or any other reason, it is the responsibility of <<customer\_short\_name>> to notify BellSouth of said change and request that an amendment to this Agreement, if necessary, be executed to reflect said change.

17.3 No modification, amendment, supplement to, or waiver of the Agreement or any of its provisions shall be effective and binding upon the Parties unless it is made in writing and duly signed by the Parties.

17.4 [Parties Disagree]

[<<customer\_short\_name>> Version] In the event that any (1) effective legislative, regulatory, judicial or other legal action or (2) obligation or commitment regarding interconnection, resale or access to network elements which obligation or commitment expressly applies generically to all CLECs made by BellSouth to any state or federal regulatory authority or the U.S. Department of Justice (“Governmental Body”) in connection with any merger or regulatory proceeding regarding BellSouth’s obligations under the Act,) materially affects any material terms of this Agreement, or the ability of <<customer\_short\_name>> or BellSouth to perform any material terms of this Agreement, <<customer\_short\_name>> or BellSouth may, on **fifteen (15)** calendar days’ written notice, require that such terms be renegotiated, and the Parties shall renegotiate in good faith such mutually acceptable new terms as may be required. In the event that such new terms are not renegotiated within **forty-five (45)** calendar days after such notice, the Dispute may at any time thereafter be resolved in accordance with the Dispute Resolution procedure set forth in this Agreement.

[BellSouth Version] In the event that any (1) effective legislative, regulatory, judicial or other legal action or (2) obligation or commitment regarding interconnection, resale or access to network elements which obligation or commitment expressly applies generically to all CLECs made by BellSouth to any state or federal regulatory authority or the U.S. Department of Justice (“Governmental Body”) in connection with any merger or regulatory proceeding regarding BellSouth’s obligations under the Act,) materially affects any material terms of this Agreement, or the ability of <<customer\_short\_name>> or BellSouth to perform any material terms of this Agreement, <<customer\_short\_name>> or BellSouth may, on **thirty (30)** calendar days’ written notice, require that such terms be renegotiated, and the Parties shall renegotiate in good faith such mutually acceptable new terms as may be required. In the event that such new terms are not renegotiated within **ninety (90)** calendar days after such notice, the Dispute may at any time thereafter be resolved in accordance with the Dispute Resolution procedure set forth in this Agreement.

18. **Non-Waiver of Legal Rights**

- 18.1 Execution of this Agreement by either Party does not confirm or imply that the executing Party agrees with any decision(s) issued pursuant to the Telecommunications Act of 1996. Neither Party waives its rights to appeal or otherwise challenge any such decision(s) and each Party reserves all of its rights to pursue any and all legal and/or equitable remedies, including appeals of any such decision(s).
19. [Parties Disagree]  
[<<customer\_short\_name>> Version] No Section.  
[BellSouth Version] Indivisibility
- 19.1 [Parties Disagree]  
[<<customer\_short\_name>> Version] No Section.  
[BellSouth Version] **Subject to the provisions of Section 20, the Parties intend that this Agreement be indivisible and nonseverable, and each of the Parties acknowledges that it has assented to all of the covenants and promises in this Agreement as a single whole and that all of such covenants and promises, taken as a whole, constitute the essence of the contract. Without limiting the generality of the foregoing, each of the Parties acknowledges that any provision by BellSouth of space for collocation under this Agreement as set forth in Attachment 4 is governed by the other applicable attachments to this Agreement. The Parties further acknowledge that this Agreement is intended to constitute a single transaction, and that the obligations of the Parties under this Agreement are interdependent.**
20. **Severability**
- 20.1 If any provision of this Agreement, or part thereof, shall be held to be invalid or unenforceable in any respect, such invalidity or unenforceability shall not invalidate the entire Agreement, unless such construction would be unreasonable. The Agreement shall be construed as if it did not contain the invalid or unenforceable provision or provisions, and the rights and obligations of each Party shall be construed and enforced accordingly. Provided, however, that in the event such invalid or unenforceable provision or provisions are essential elements of this Agreement and substantially impair the rights or obligations of either Party, the Parties shall promptly negotiate a replacement provision or provisions. In the event the Parties are unable to mutually negotiate such replacement language, either Party may elect to pursue the dispute resolution process set forth in Section 13 above.
21. **No Waiver**
- 21.1 A failure or delay of either Party to enforce any of the provisions hereof, to exercise any option which is herein provided, or to require performance of any of the provisions hereof shall in no way be construed to be a waiver of such

provisions or options, and each Party, notwithstanding such failure, shall have the right thereafter to insist upon the performance of any and all of the provisions of this Agreement.

22. **Governing Law**

22.1 Where applicable, this Agreement shall be governed by and construed in accordance with federal and state substantive telecommunications law, including rules and regulations of the FCC and appropriate Commission. In all other respects, this Agreement shall be governed by and construed and enforced in accordance with the laws of the State of Georgia without regard to its conflict of laws principles.

23. **Assignments**

23.1 Except as provided herein, any assignment by either Party to any non-affiliated entity of any right, obligation or duty, or of any other interest hereunder, in whole or in part, without the prior written consent of the other Party shall be void. A Party may assign this Agreement or any right, obligation, duty or other interest hereunder to an Affiliate of the Party or to an entity purchasing all or substantially all of the Party's assets without the consent of the other Party; provided, however, that the assigning Party shall notify the other Party in writing of such assignment thirty (30) calendar days prior to the Effective Date thereof and, provided further, if the assignee is an assignee of <<customer\_short\_name>>, the assignee must provide evidence of Commission CLEC certification. The Parties shall amend this Agreement to reflect such assignments and shall work cooperatively to implement any changes required due to such assignment. All obligations and duties of any Party under this Agreement shall be binding on all successors in interest and assigns of such Party. No assignment or delegation hereof shall relieve the assignor of its obligations under this Agreement in the event that the assignee fails to perform such obligations. Notwithstanding anything to the contrary in this Section and unless the Parties agree otherwise, <<customer\_short\_name>> shall not assign this Agreement to any Affiliate or non-affiliated entity unless either (1) <<customer\_short\_name>> pays all bills, past due and current, under this Agreement, or (2) <<customer\_short\_name>>'s assignee expressly assumes liability for payment of such bills.

24. **Notices**

24.1 Every notice, consent, approval, or other communications required or contemplated by this Agreement shall be in writing and shall be delivered by hand, by overnight courier or by U.S. Mail postage prepaid, addressed to:

**BellSouth Telecommunications, Inc.**

BellSouth Local Contract Manager  
600 North 19<sup>th</sup> Street, 8<sup>th</sup> floor  
Birmingham, Alabama 35203

and

ICS Attorney  
Suite 4300  
675 W. Peachtree St.  
Atlanta, GA 30375

<<customer\_name>>

\_\_\_\_\_  
\_\_\_\_\_  
\_\_\_\_\_

24.2 Unless otherwise provided in this Agreement, notice by mail shall be effective on the date it is officially recorded as delivered by return receipt or equivalent, and in the absence of such record of delivery, it shall be presumed to have been delivered the fifth (5<sup>th</sup>) calendar day, or next business day after the fifth (5<sup>th</sup>) calendar day, after it was deposited in the mail. Notice by overnight courier shall be effective on the date it was delivered, except that notice delivered on a non-business day shall be deemed effective on the next business day.

24.3 Subject to Section 45.2 below, BellSouth will post changes to business processes and policies, notices of new service offerings, and changes to service offerings not requiring an amendment to this Agreement, notices required to be posted to BellSouth's web site, and any other information of general applicability to <<customer\_short\_name>>.

25. **Rule of Construction**

25.1 No rule of construction requiring interpretation against the drafting Party hereof shall apply in the interpretation of this Agreement.

26. **Headings of No Force or Effect**

26.1 The headings of Articles and Sections of this Agreement are for convenience of reference only, and shall in no way define, modify or restrict the meaning or interpretation of the terms or provisions of this Agreement.

27. **Cooperation in Preventing End User Fraud**

27.1 The Parties agree to cooperate fully with one another to investigate, minimize, prevent and take action in cases of fraud by an End User involving the provision of services to <<customer\_short\_name>> under this Agreement.

28. **Revenue Protection**

28.1 BellSouth shall make available to <<customer\_short\_name>> fraud prevention or revenue protection features, including prevention, detection, or control functionality embedded within any of the Network Elements or services provided pursuant to this Agreement. These features include switch functions such as screening codes and call blocking of international, 900 and 976 numbers. To the extent separate charges apply for such features, the charges will be set forth in the appropriate attachment to this Agreement or will be negotiated between the Parties and added to this Agreement via an amendment at such time as <<customer\_short\_name>> requests the features.

29. **Law Enforcement Interface**

29.1 Both Parties shall work cooperatively to comply with all legal or regulatory requirements related to number recording devices, including, for example, orders related to trap and trace and wire taps.

30. **Multiple Counterparts**

30.1 This Agreement may be executed in multiple counterparts, each of which shall be deemed an original, but all of which shall together constitute but one and the same document.

31. **Filing of Agreement**

31.1 Upon execution of this Agreement BellSouth shall file the Agreement with the appropriate state regulatory agency pursuant to the requirements of Section 252 of the Act. Notwithstanding the foregoing, this Agreement shall not be submitted for approval by the appropriate state regulatory agency unless and until such time as <<customer\_short\_name>> is duly certified as a local exchange carrier in such state, except as otherwise required by a Commission.

32. **Compliance with Applicable Law**

32.1 Each Party shall comply at its own expense with all applicable federal, state, and local statutes, laws, rules, regulations, codes, effective orders, injunctions, judgments and binding decisions, awards and decrees that relate to its obligations under this Agreement (“Applicable Law”).

32.2 [Parties Disagree]

[<<customer\_short\_name>> Version] **Nothing in this Agreement shall be construed to limit a Party’s rights or exempt a Party from obligations under Applicable Law, except in such cases where the Parties have explicitly agreed to a limitation or exemption. Silence shall not be construed to be such a limitation or exemption with respect to any aspect, no matter how discrete, of Applicable Law.**



**[BellSouth Version]** This Agreement is intended to memorialize the Parties' mutual agreement with respect to their obligations under the Act and applicable FCC and Commission rules and orders. Any reference to the Parties complying with applicable FCC and Commission orders is not intended to expand on the obligations of the Parties as set forth herein.

32.3

[Parties Disagree]

**[<<customer\_short\_name>> Version]** The rates contained in this Agreement shall be in compliance with Applicable Law. Where a Commission has adopted rates for network elements or services provided under this Agreement, as of the Effective Date, it is the intent of the Parties that the rate exhibits incorporated into this Agreement will be those rates. Errors in rate sheets will be corrected by **retroactive true-up to the Effective Date within thirty (30) calendar days.**

**[BellSouth Version]** Where a Commission has adopted rates for network elements or services provided under this Agreement, as of the Effective Date, it is the intent of the Parties that the rate exhibits incorporated into this Agreement will be those rates, unless otherwise negotiated by the Parties. Upon request of either Party, errors in rate sheets will be corrected **prospectively by amendments to this Agreement.**

33.

### **Necessary Approvals**

33.1

Each Party shall be responsible for obtaining and keeping in effect all approvals from, and rights granted by, governmental authorities, building and property owners, other carriers, and any other persons that may be required in connection with the performance of its obligations under this Agreement. Each Party shall reasonably cooperate with the other Party in obtaining and maintaining any required approvals and rights for which such Party is responsible.

34.

### **Good Faith Performance**

34.1

Each Party shall act in good faith in its performance under this Agreement. Where notice, approval, consent, agreement or similar action by a Party is permitted or required by any provision of this Agreement (including without limitation, the obligation of the Parties to further negotiate the resolution of new or open issues under this Agreement), such action will not be unreasonably delayed, withheld or conditioned.

34.2

[Parties Disagree]

**[<<customer\_short\_name>> Version]** Neither Party shall, as a condition or prerequisite to such Party's performance of its obligations as otherwise provided herein, impose or insist upon the other Party's (or any of its End Users') adherence to any requirement or obligation other than as expressly stipulated in this Agreement or as otherwise mandated by Applicable Law.

[BellSouth Version] No Section.

35. **Independent Contracting Parties**

35.1 Each Party is an independent contractor, and has and hereby retains the right to exercise full control of and supervision over its own performance of its obligations under this Agreement, and retains full control over the employment, direction, compensation and discharge of its employees assisting in the performance of such obligations. Each Party shall be solely responsible for all matters relating to payment of such employees, including compliance with social security taxes, withholding taxes and all other regulations governing such matters. Subject to the limitations on liability and except as otherwise provided in this Agreement, each Party shall be responsible for (i) its own acts and performance of all obligations imposed by Applicable Law in connection with its activities, legal status and property, real or personal and, (ii) the acts of its own Affiliates, employees, agents and contractors during the performance of the Party's obligations hereunder.

36. **Subcontracting**

36.1 If any obligation is performed through a subcontractor, each Party shall remain fully responsible for the performance of this Agreement in accordance with its terms, including any obligations either Party performs through subcontractors, and each Party shall be solely responsible for payments due the Party's subcontractors. No contract, subcontract or other Agreement entered into by either Party with any third party in connection with the provision of any facilities or services provided herein, shall provide for any indemnity, guarantee or assumption of liability by, or other obligation of, the other Party to this Agreement with respect to such arrangement, except as consented to in writing by the other Party. No subcontractor shall be deemed a third party beneficiary for any purposes under this Agreement. Any subcontractor who gains access to CPNI or Confidential Information covered by this Agreement shall be required by the subcontracting Party to protect such CPNI or Confidential Information to the same extent that the subcontracting Party is required to protect the same under the terms of this Agreement.

37. **Labor Relations**

37.1 The Parties shall endeavor to minimize impairment of service to the other Party in the event of a labor dispute to the extent permitted by Applicable Law.

38. **Compliance with the Communications Assistance for Law Enforcement Act of 1994 ("CALEA")**

38.1 Each Party represents and warrants that any equipment, facilities or services provided to the other Party under this Agreement comply with CALEA. Each Party shall indemnify and hold the other Party harmless from any and all penalties imposed upon the other Party for such other Party's noncompliance.

39. **Customer Inquiries**

39.1 Calls About the Other Party's Products and Services. Each Party shall refer all questions regarding the other Party's services or products directly to the other Party at a telephone number specified by the other Party. Each Party shall ensure that all their representatives who receive inquiries regarding the other Party's services or products: (i) provide such numbers, if available to the personnel receiving the call, to callers who inquire about the other Party's services or products; (ii) do not in any way disparage or discriminate against the other Party, or its products or services; and (iii) do not provide information about their products or services during that same inquiry/subscriber contact, unless that information specifically is requested by the caller. Subject to the limitations of this Section, both Parties maintain the right to serve directly any End User within the service area of the other Party. Both Parties may directly market their own telecommunications products and services and in doing so may establish independent relationships with End Users of the other Party.

40. **Additional Fair Competition Requirements**

40.1 In the event that BellSouth transfers facilities or other assets to an Affiliate during the term of this Agreement, which are necessary in order for BellSouth to comply with its obligations under this Agreement, and BellSouth is required by law to continue to provide such interconnection, services or network elements under this Agreement even after such transfer, then such obligations hereunder shall survive and BellSouth shall continue to perform such obligations. In the event that BellSouth transfers facilities or other assets to an Affiliate during the term of this Agreement, which are necessary in order for BellSouth to comply with its obligations under this Agreement, and BellSouth is relieved of its obligations to provide such interconnection, services or network elements, but such Affiliate is required by law to perform such obligations to the extent that BellSouth was required to, then BellSouth shall be relieved of its obligations hereunder and such obligations shall survive and transfer to such Affiliate pursuant to the Assignment Section hereof.

40.2 BellSouth shall allow <<customer\_short\_name>>'s local exchange customers to select BellSouth for the provision of intraLATA toll services to the extent BellSouth makes such stand alone intraLATA services available to the general public on a nondiscriminatory basis.

40.3 Each Party shall protect the confidentiality of proprietary information of, and relating to, the other Party and its End Users or any other carrier. If either Party receives or obtains proprietary information from the other for the purposes of providing services under this agreement, such Party shall use such information only for such purpose and shall not use such information for its own marketing purpose.

41. **Posting of Agreements**

41.1 BellSouth shall post on its web site any BellSouth interconnection agreement between BellSouth and any third party no later than ten (10) calendar days after the approval of such agreement with the Commission.

42. **Nonexclusive Dealings**

42.1 This Agreement does not prevent either Party from providing or purchasing services to or from any other person.

43. **Rate True-Up**

43.1 This Section applies to Network Interconnection and/or Unbundled Network Elements and Other Services rates that are expressly subject to true-up under this Agreement.

43.2 The designated true-up rates shall be true-up, either up or down, based on final prices determined either by further agreement between the Parties, or by a final order of the Commission. The Parties shall implement the true-up by comparing the actual volumes and demand for each item, together with the designated true-up rates for each item, with the final prices determined for each item. Each Party shall keep its own records upon which the true-up can be based, and any final payment from one Party to the other shall be in an amount agreed upon by the Parties based on such records. In the event of any disagreement as between the records or the Parties regarding the amount of such true-up, the Parties shall submit the matter to the Dispute Resolution process in accordance with the provisions of Section 13 above of the General Terms and Conditions of this Agreement.

44. **Survival**

44.1 In no event shall the expiration or termination for any reason of this Agreement relieve either Party of any liability or obligation accruing in favor of the other Party in respect of acts or omissions occurring prior thereto. Any liabilities and all obligations of each Party under the provisions regarding indemnification, confidentiality of information, liability, and any other provisions of this Agreement that by their specific nature or express terms are contemplated to survive (or be performed) thereafter shall survive expiration or termination.

45. **Entire Agreement**

45.1 This Agreement means the General Terms and Conditions, the Attachments identified in Section 45.4 below, and subject to the limitations set forth in Section 45.2 all documents identified herein. This Agreement sets forth the entire understanding and supersedes prior agreements between the Parties relating to the subject matter contained in this Agreement and merges all prior discussions between them. Any orders placed under prior agreements between the Parties shall be governed by the terms of this Agreement. Any and all amounts and obligations owed for services provisioned or orders placed under prior agreements

between the Parties, related to the subject matter hereof, shall be due and owing under this Agreement and be governed by the terms and conditions of this Agreement as if such services or orders were provisioned or placed under this Agreement. Neither Party shall be bound by any definition, condition, provision, representation, warranty, covenant or promise other than as expressly stated in this Agreement or as is contemporaneously or subsequently set forth in writing and executed by a duly authorized officer or representative of the Party to be bound thereby.

45.2

[Parties Disagree]

[<<customer\_short\_name>> Version] Guides. The Parties acknowledge that certain provisions of this Agreement reference certain BellSouth documents and publications (collectively referred to herein as the "Guides"). All Guides referred to in this Agreement, are incorporated herein and made a part hereof by reference. To the extent that there is a conflict between a provision of a Guide and a provision of this Agreement, the provision of this Agreement shall prevail. BellSouth may, from time to time during the term hereof, change or alter said Guides (including replacing a Guide entirely with a successor Guide with a different name). The Parties agree that if the change or alteration was made to BellSouth's OSS interface Guides as a result of the Change Control Process (CCP), a revision to a generally accepted and implemented industry standard or guideline (e.g. Ordering Billing Forum (OBF), Telcordia guidelines, etc.), or other legal requirement directly affecting the Guides provided, if such legal requirement would be subject to the change of law provision in these General Terms and Conditions, the change to the Guide would not be applicable until this Agreement is amended to reflect the update to the Guide, or if <<customer\_short\_name>> agrees to such change or alteration, any such change or alteration shall become effective as specified in the terms of the notice to <<customer\_short\_name>> via the applicable Internet website posting. In all other cases, a change in a Guide which (1) alters, amends or conflicts with any term of this Agreement; (2) changes any charge or rate, or the application of any charge or rate, specified in this Agreement; (3) adds a new rate or rate element not previously specified in the Agreement; (4) causes <<customer\_short\_name>> to incur material cost or expense to implement the change or alteration; or (5) increases an interval set forth in this agreement, will not be effective with respect to <<customer\_short\_name>> until BellSouth and <<customer\_short\_name>> sign an amendment to this Agreement reflecting the changes described in items (1), (2), (3), (4) or (5). For purposes of item (4), a cost or expense shall be deemed material if it imposes a financial burden on <<customer\_short\_name>>, but shall not include costs associated with disseminating notice of the change or providing training regarding the change to employees. In addition, BellSouth will use its best efforts, upon <<customer\_short\_name>>'s request to BellSouth's Interconnection Services (ICS) website group at [wmag@bellsouth.com](mailto:wmag@bellsouth.com), to provide such notices via e-mail to the address specified by <<customer\_short\_name>>.

In the event that the Parties disagree as to whether any alteration or amendment described in this Section is effective as to <<customer\_short\_name>> pursuant to the requirements of this Section, either Party may, at its option, seek resolution of the dispute in accordance with the Dispute Resolution provisions in the General Terms and Conditions of this Agreement. In cases where there is a dispute with respect to any alteration or amendment described in this Section becoming effective as to <<customer\_short\_name>>, such alteration or amendment described in this Section shall not become effective as to <<customer\_short\_name>> until there is mutual agreement between the Parties that it should become effective or an order resulting from the Dispute Resolution process finding in favor of its becoming effective.

[BellSouth Version] Guides. The Parties acknowledge that certain provisions of this Agreement reference certain BellSouth documents and publications (collectively referred to herein as the "Guides"). All Guides referred to in this Agreement, are incorporated herein and made a part hereof by reference. To the extent that there is a conflict between a provision of a Guide and a provision of this Agreement, the provision of this Agreement shall prevail. BellSouth may, from time to time during the term hereof, change or alter said Guides (including replacing a Guide entirely with a successor Guide with a different name). The Parties agree that if the change or alteration was made to BellSouth's OSS interface Guides as a result of the Change Control Process (CCP), a revision to a generally accepted and implemented industry standard or guideline (e.g. Ordering Billing Forum (OBF), Telcordia guidelines, etc.), or other legal requirement directly affecting the Guides provided, if such legal requirement would be subject to the change of law provision in these General Terms and Conditions, the change to the Guide would not be applicable until this Agreement is amended to reflect the update to the Guide, or if <<customer\_short\_name>> agrees to such change or alteration, any such change or alteration shall become effective as specified in the terms of the notice to <<customer\_short\_name>> via the applicable Internet website posting. In all other cases, a change in a Guide which (1) alters, amends or conflicts with any term of this Agreement; (2) changes any charge or rate, or the application of any charge or rate, specified in this Agreement; (3) adds a new rate or rate element not previously specified in the Agreement; (4) causes <<customer\_short\_name>> to incur material cost or expense to implement the change or alteration; or (5) increases an interval set forth in this agreement, will not be effective with respect to <<customer\_short\_name>> until BellSouth and <<customer\_short\_name>> sign an amendment to this Agreement reflecting the changes described in items (1), (2), (3) or (5); **or unless <<customer\_short\_name>> fails to inform BellSouth in writing that it does not agree to such change or alteration within thirty (30) calendar days of notice of such change being given to <<customer\_short\_name>> for item (4).** For purposes of item (4), a cost or expense shall be deemed material if it imposes a financial burden on <<customer\_short\_name>>, but shall not include costs associated with disseminating notice of the change or providing training regarding the change to employees. In addition, BellSouth will use its best efforts, upon

<<customer\_short\_name>>'s request to BellSouth's Interconnection Services (ICS) website group at wmag@bellsouth.com, to provide such notices via e-mail to the address specified by <<customer\_short\_name>>.

In the event that the Parties disagree as to whether any alteration or amendment described in this Section is effective as to <<customer\_short\_name>> pursuant to the requirements of this Section, either Party may, at its option, seek resolution of the dispute in accordance with the Dispute Resolution provisions in the General Terms and Conditions of this Agreement. In cases where there is a dispute with respect to any alteration or amendment described in this Section becoming effective as to <<customer\_short\_name>>, such alteration or amendment described in this Section shall not become effective as to <<customer\_short\_name>> until there is mutual agreement between the Parties that it should become effective or an order resulting from the Dispute Resolution process finding in favor of its becoming effective.

45.3

[Parties Disagree]

[<<customer\_short\_name>> Version] In various provisions of this Agreement, the Parties have included references to tariffs filed by the Parties. If such tariff is referenced for the purposes of a service that is provisioned pursuant to such tariff, and there is a conflict between such referenced tariff provisions and this Agreement, the terms of the tariff shall control. If the service is provisioned pursuant to this Agreement but the tariff is referenced for a rate, an interval or another purpose, to the extent that there is a conflict between such referenced tariff provision and this Agreement, and except as otherwise set forth in this Agreement, the terms of this Agreement shall prevail. To the extent a Party alleges that changes made to such tariffs subsequent to the Effective Date are unreasonable and discriminatory, the Parties shall endeavor to negotiate a resolution and incorporate such resolution into this Agreement by written amendment. To the extent that the Parties are unable to reach such resolution or agree on an amendment, the dispute shall be resolved in accordance with the Dispute Resolution provisions set forth in Section 13 above.

[BellSouth Version] In various provisions of this Agreement, the Parties have included references to tariffs filed by the Parties. If such tariff is referenced for the purposes of a service that is provisioned pursuant to such tariff, and there is a conflict between such referenced tariff provisions and this Agreement, the terms of the tariff shall control. If the service is provisioned pursuant to this Agreement but the tariff is referenced for a rate, an interval or another purpose, to the extent that there is a conflict between such referenced tariff provision and this Agreement, and except as otherwise set forth in this Agreement, the terms of this Agreement shall prevail.

45.4

This Agreement includes eleven (11) Attachments with provisions for the following:

Resale

Network Elements and Other Services

Network Interconnection  
Collocation  
Access to Numbers and Number Portability  
Pre-Ordering, Ordering, Provisioning, Maintenance and Repair  
Billing  
Rights-of-Way, Conduits and Pole Attachments  
Performance Measurements  
BellSouth Disaster Recovery Plan  
Bona Fide Request/New Business Request Process

45.5 The following services are included as options for purchase by <<customer\_short\_name>> pursuant to the terms and conditions set forth in this Agreement. <<customer\_short\_name>> may elect to purchase said services by written request to its Local Contract Manager if applicable:

Optional Daily Usage File (ODUF)  
Enhanced Optional Daily Usage File (EODUF)  
Access Daily Usage File (ADUF)  
Line Information Database (LIDB) Storage  
Centralized Message Distribution Service (CMDS)  
Calling Name (CNAM)  
LNP Data Base Query Service



**KMC / NUVOX / NEWSOUTH / XSPEDIUS - BELLSOUTH ARBITRATION  
JOINT ISSUES/OPEN ITEMS MATRIX**

[AS OF 2/11/04]

ITEM No.	ISSUE #	§	UNRESOLVED ISSUE	CLEC POSITION	BELLSOUTH POSITION
<b>GT&amp;Cs (MAIN)</b>					
1	G-1	1.6	<i>What should be the effective date of future rate impacting amendments?</i>	Future amendments incorporating Commission-approved rates should be effective as of the effective date of the Commission order, if an amendment is requested within 30 calendar days of that date. Otherwise, such amendments should be effective 10 calendar days after request.	Future amendments incorporating Commission-approved rates should be effective ten (10) calendar days after the date of the last signature executing the amendment.
2	G-2	1.7	<i>How should "End User" be defined?</i>  [BellSouth will either concur in CLECs' statement of the issue or provide an alternative statement with its Response]	The term "End User" should be defined as "the customer of a Party".	BellSouth will provide its position with its Response.
3	G-3	10.2	<i>Should the agreement contain a general provision providing that BellSouth shall take financial responsibility for its own actions in causing, or contributing to unbillable or uncollectible CLEC revenue in addition to specific provisions set forth in Attachments 3 and 7?</i>	YES, BellSouth should be financially liable for causing, failing to prevent, or contributing to unbillable or uncollectible CLEC revenue. A general provision complements the specific provisions contained in Attachments 3 and 7.	NO. The Parties have negotiated specific provisions in Attachments 3 and 7 addressing responsibility for billing records deficiencies.

ITEM No.	ISSUE #	§	UNRESOLVED ISSUE	CLEC POSITION	BELL SOUTH POSITION
4	G-4	10.4.1	<i>What should be the limitation on each Party's liability in circumstances other than gross negligence or willful misconduct?</i>	In cases other than gross negligence and willful misconduct by the other party, or other specified exemptions as set forth in CLECs' proposed language, liability should be limited to an aggregate amount over the entire term equal to 7.5% of the aggregate fees, charges or other amounts paid or payable for any and all services provided or to be provided pursuant to the Agreement as of the day immediately preceding the date of assertion or filing of the applicable claim or suit. CLECs' proposal represents a hybrid between limitation of liability provisions typically found in commercial contracts between sophisticated buyers and sellers, in the absence of overwhelming market dominance by one party, and the effective elimination of liability provision proposed by BellSouth.	The industry standard limitation of liability should apply, which limits the liability of the provisioning party to a credit for the actual cost of the services or functions not performed or improperly performed.
5	G-5	10.4.2	<i>Should each Party be required to include specific liability-eliminating terms in all of its tariffs and End User contracts (past, present and future), and, to the extent that a Party does</i>	NO, BellSouth should not be able to dictate the terms of service between CLEC and its End Users by, among other things, holding CLEC liable for failing to mirror BellSouth's limitation of liability and indemnification provisions in CLEC's End User tariffs and/or contracts. To the extent	BellSouth Issue Statement: <i>If the CLEC elects not to place in its contracts with end users and/or tariffs standard industry limitations of liability, who should bear the risks that result from this business decision.</i>

ITEM No.	ISSUE #	§	UNRESOLVED ISSUE	CLEC POSITION	BELL SOUTH POSITION
			<p><i>not or is unable to do so, should it be obligated to indemnify the other Party for liabilities not eliminated?</i></p> <p>[BellSouth does not concur in this statement of the issue]</p>	<p>that a Party does not, or is unable to, include specific elimination-of-liability terms in all of its tariffs and End User contracts (past, present and future), and provided that the non-inclusion of such terms is commercially reasonable, that Party should not be required to indemnify and reimburse the other Party for that portion of the loss that would have been limited had the first Party included in its tariffs and contracts the elimination-of-liability terms that such other Party included in its tariffs at the time of such loss.</p>	<p>BellSouth Position: If a CLEC elects not to limit its liability to its end users/customers in accordance with industry norms, the CLEC should bear the risk of loss arising from that business decision.</p>
6	G-6	10.4.4	<p><i>Should limitation on liability for indirect, incidental or consequential damages be construed to preclude liability for claims or suits for damages incurred by CLEC's (or BellSouth's) End Users to the extent such damages result directly and in a reasonably foreseeable manner from BellSouth's (or CLEC's) performance obligations set forth in the Agreement?</i></p> <p>[BellSouth will either concur with CLECs' statement of the</p>	<p>NO, the Agreement, by its nature, contemplates that End Users will be served via the exchange of traffic through interconnection arrangements and through the use of UNEs and Other Services purchased. Damages to End Users that result directly and in a reasonably foreseeable manner from BellSouth's (or CLEC's) performance of obligations set forth in the Agreement that were not and are not directly and proximately caused by or are the result of CLEC's (or BellSouth's) failure to act at all relevant times in a commercially reasonable manner in compliance with CLEC's (or BellSouth's) duties of mitigation with respect to such damage should be considered direct under the Agreement for simple negligence</p>	<p>BellSouth will provide its position with its Response.</p>

ITEM No.	ISSUE #	§	UNRESOLVED ISSUE	CLEC POSITION	BELL SOUTH POSITION
			issue or provide an alternative statement with its Response]	purposes.	
7	G-7	10.5	<i>What should the indemnification obligations of the parties be under this Agreement?</i>	The Party providing service under the Agreement should be indemnified, defended and held harmless by the Party receiving services against any claim for libel, slander or invasion of privacy arising from the content of the receiving Party's own communications. Similarly, the Party receiving services under the Agreement should be indemnified, defended and held harmless by the Party providing services against any claims, loss or damage to the extent arising from: (1) the providing Party's failure to abide by Applicable Law, or (2) injuries or damages arising out of or in connection with this Agreement to the extent caused by the providing Party's negligence, gross negligence or willful misconduct.	The Party receiving services should indemnify the party providing services from (1) any claim loss or damages from claims for libel, slander or invasion of privacy arising from the content of the receiving party's own communications, or (2) any claim, loss or damage claimed by the end user of the Party receiving services arising out of the Agreement.
8	G-8	11.1	<i>What language should be included in the Agreement regarding a Party's use of the other Party's name, service marks and trademarks?</i>  [BellSouth will either concur with CLECs' statement of the issue or provide an alternative statement with its Response]	Given the complexity of and variability in intellectual property law, this nine-state Agreement should simply state that no patent, copyright, trademark or other proprietary right is licensed, granted or otherwise transferred by the Agreement and that a Party's use of the other Party's name, service mark and trademark should be in accordance with Applicable Law. The Commission should not attempt to prejudge intellectual property law issues, which at	BellSouth will provide its position with its Response.

ITEM No.	ISSUE #	§	UNRESOLVED ISSUE	CLEC POSITION	BELL SOUTH POSITION
				BellSouth's insistence, the Parties have agreed are best left to adjudication by courts of law (see, GTC, Sec. 11.5).	
9	G-9	13.1	<p><i>Should a court of law be included among the venues at which a Party may seek dispute resolution under the Agreement?</i></p> <p>[BellSouth does not concur in this statement of the issue]</p>	<p>YES, either Party should be able to petition the Commission, the FCC or a court of law for resolution of a dispute. Given the difficulties experienced in achieving efficient regional dispute resolution, and the ongoing debate as to whether state commissions have jurisdiction to enforce agreements (CLECs do not dispute that authority) and as to whether the FCC will engage in such enforcement (or not), no legitimate dispute resolution venue should be foreclosed. There is no question that courts of law have jurisdiction to entertain such disputes (see GTC, Sec. 11.5); indeed, in certain instances, they may be better equipped to adjudicate a dispute and may provide a more efficient alternative to litigating in up to 9 different jurisdictions or to waiting for the FCC to decide whether it will or won't accept an enforcement role given the particular facts.</p>	<p>BellSouth Issue Statement: <i>Should a party be allowed to take a dispute concerning the interpretation or implementation of any provision of the agreement to a Court of law for resolution without first exhausting its administrative remedies?</i></p> <p>BellSouth Position: This Commission or the FCC should resolve disputes as to the interpretation of the Agreement or as to the proper implementation of the Agreement. A party should be entitled to seek judicial review of any ruling made by the Commission or the FCC concerning this Agreement, but should not be entitled to take such disputes to a Court of law without first exhausting its administrative remedies.</p>
10	G-10	17.4	<p><i>(A) How much notice should be given by a Party requesting a change of law amendment?</i></p> <p><i>(B) How much time must elapse before a Party may</i></p>	<p>(A) The Party requesting renegotiation should give 15 calendar days notice.</p> <p>(B) In the event that changes to the Agreement necessitated by a change of law are not renegotiated within 45 days after notice of renegotiation, either Party may</p>	<p>BellSouth will provide its position with its Response.</p>

ITEM No.	ISSUE #	§	UNRESOLVED ISSUE	CLEC POSITION	BELL SOUTH POSITION
			<p><i>seek dispute resolution pursuant to the dispute resolution procedures of the agreement, absent successful negotiation of and agreement by the Parties on such an amendment?</i></p> <p>[BellSouth will either concur with CLECs' statement of the issue or provide an alternative statement with its Response]</p>	<p>invoke the Dispute Resolution procedures of the agreement, as it deems appropriate. The 45 day period is not a deadline. Rather, it establishes a reasonable minimum time frame during which the Parties must attempt to negotiate an amendment without resorting to dispute resolution. After 45 days have passed, each Party should use discretion and good judgment prior to resorting to Dispute Resolution, as with respect to some amendments, it may take months to sort through the issues and complete a good faith attempt at reaching resolution without intervention.</p>	
11	G-11	19, 19.1	<p><i>For the purpose of bankruptcy law, should the Agreement be considered indivisible?</i></p>	<p>NO, it is neither necessary nor proper to amalgamate or pre-decide bankruptcy law in the context of this Agreement. All provisions of the Agreement were not negotiated as a "single whole" or as a "single transaction" and not all of the provisions or obligations set forth therein are "interdependent". BellSouth's proposed language impermissibly subverts, the requirements of section 252(i) of the Communications Act, FCC Rule 51.809, and Section 17.1 of the General Terms and Conditions.</p>	<p>YES. The Parties have negotiated this agreement as a whole and do not consider each attachment to be a separate contract, divisible from the general terms and conditions, and every other applicable attachment.</p>
12	G-12	32.2	<p><i>Should the Agreement explicitly state that all existing state and federal laws, rules, regulations,</i></p>	<p>YES, nothing in the Agreement should be construed to limit a Party's rights or exempt a Party from obligations under Applicable Law, as defined in the Agreement, except in</p>	<p>This Agreement constitutes the contractual obligations of the Parties to each other and should not be subject to further negotiation subsequent to being</p>

ITEM No.	ISSUE #	§	UNRESOLVED ISSUE	CLEC POSITION	BELLSOUTH POSITION
			<i>and decisions apply unless otherwise specifically agreed to by the Parties?</i>	such cases where the Parties have explicitly agreed to a limitation or exemption. This is a basic legal tenet and is consistent with both federal and Georgia law (agreed to by the parties), and it should be explicitly stated in the Agreement in order to avoid unnecessary disputes and litigation that has plagued the Parties in the past.	fully negotiated and arbitrated.
13	G-13	32.3	<i>How should the Parties deal with non-negotiated deviations from the state Commission- approved rates in the rate sheets attached to the Agreement?</i>	Any non-negotiated deviations from ordered rates should be corrected by retroactive true-up to the effective date of the Agreement within 30 calendar days of the date the error was identified by either Party.	Any non-negotiated deviations from ordered rates should be changed by amendment of the agreement upon discovery by a party and should be applied prospectively regardless of whether the rate increases or decreases as a result of such amendment.
14	G-14	34.2	<i>Can either Party require, as a prerequisite to performance of its obligations under the Agreement, that the other Party adhere to any requirement other than those expressly stipulated in the Agreement or mandated by Applicable Law?</i>	NO, the Parties should not be permitted to hold performance hostage to terms not included in the Agreement and not mandated by Applicable Law. More specifically, neither Party should, as a condition or prerequisite to such Party's performance of its obligations under the Agreement, impose or insist upon the other Party's (or any of its End Users') adherence to any requirement or obligation other than as expressly stipulated in this Agreement or as otherwise mandated by Applicable Law.	YES. The Parties are free to negotiate with each other as they may with third parties. Neither Party should use this agreement to interfere with a third party's contractual rights and obligations.
15	G-15	45.2	<i>If BellSouth changes a provision of one or more of its Guides that would cause CLEC to incur a material</i>	NO, if the contemplated change to one or more of BellSouth's Guides would cause CLEC to incur a material cost or expense to implement the change, BellSouth and CLEC	YES. BellSouth's Guides apply to all CLEC's equally. If BellSouth allows a CLEC the right to opt out of the requirements of a Guide, the CLEC

ITEM No.	ISSUE #	§	UNRESOLVED ISSUE	CLEC POSITION	BELL SOUTH POSITION
			<i>cost or expense to implement the change, should the CLEC notify BellSouth, in writing, if it does not agree to the change?</i>	should negotiate an amendment to the Agreement to incorporate such change.	should notify BellSouth of its decision to do so.
16	G-16	45.3	<p><i>Should the obligations set forth in the Agreement be impacted by unreasonable and/or discriminatory revisions to BellSouth tariffs?</i></p> <p>[BellSouth does not concur in this statement of the issue]</p>	NO, unreasonable and/or discriminatory revisions to BellSouth’s tariffs should not affect the obligations set forth in the Agreement. Specifically, to the extent that tariff changes are inconsistent with the provisions of the Agreement, or are unreasonable or discriminatory, they should not supersede the Agreement. Such changes may only become part of the Agreement by written amendment negotiated and/or arbitrated by the Parties.	<p>BellSouth Issue Statement: <i>If a tariff is referenced in the Agreement, what effect should subsequent changes to the tariff have on the Agreement?</i></p> <p>BellSouth Position: If a service is purchased pursuant to a tariff that is referenced in the Agreement, the terms of that tariff at the time of the purchase should apply. This Commission already has procedures in place pursuant to which BellSouth may revise its tariffs, and pursuant to which a CLEC, or any other party, may object to such revisions. There should be no requirement that tariff revisions that occur after the Agreement becomes effective be incorporated into the Agreement by amendment.</p>
<b>RESALE (ATTACHMENT 1)</b>					
17	1-1	3.19	<i>How much advance notice must BellSouth give CLEC before discontinuing a service or increasing the price of a service?</i>	BellSouth must provide electronically to CLEC forty-five (45) days advance notice of changes to the prices, terms or conditions of services available for Resale, including but not limited to, discontinuances and price	If a CLEC is under a commission requirement to provide notice to its end users of price increases or discontinuance of services, BellSouth should provide 10 days notice prior to



ITEM No.	ISSUE #	§	UNRESOLVED ISSUE	CLEC POSITION	BELL SOUTH POSITION
				increases.	the CLEC's obligation to provide notice to its end users.
18	1-2	11.6.6	<p><i>For the purpose of connecting to BellSouth's TOPS platform, should CLEC be entitled to purchase from BellSouth transport facilities and trunks at TELRIC-compliant rates where such transport facilities and trunks are available as UNEs?</i></p> <p>[BellSouth does not concur in this statement of the issue]</p>	YES, for the purpose of connecting to BellSouth's TOPS, CLEC should be entitled to purchase from BellSouth transport facilities or trunks at TELRIC rates where such transport facilities and trunks are available as UNEs.	<p>BellSouth Issue Statement: <i>Should CLEC be entitled to purchase from BellSouth dedicated transport or trunks at TELRIC compliant rates to connect a BellSouth end office to BellSouth's TOPS or CLEC's operator service provider?</i></p> <p>BellSouth Position: No, dedicated transport or trunks to BellSouth's or CLEC's TOPS should be at tariffed rates.</p>
<b>NETWORK ELEMENTS (ATTACHMENT 2)</b>					
19	2-1	1.1	<p><i>(A) To what extent shall obligations set forth in FCC rules and orders and Commission rules and orders apply?</i></p> <p><i>(B) To the extent that there is a conflict between Attachment 2 and any other provision of the Agreement, should the provisions in Attachment 2 control?</i></p> <p>[BellSouth will either concur</p>	(A) In general, Attachment 2 is not intended to eliminate obligations set forth in FCC rules and orders and Commission rules and orders. However, to the extent obligations are addressed in the text of Attachment 2 and that text conflicts with obligations set forth in FCC rules and orders and Commission rules and orders, the text of Attachment 2 should prevail. Conversely, to the extent obligations set forth in FCC rules and orders and Commission rules and orders are not addressed in Attachment 2, those obligations should apply unless the text of Attachment 2 expressly states that a	BellSouth will provide its position with its Response.

ITEM No.	ISSUE #	§	UNRESOLVED ISSUE	CLEC POSITION	BELL SOUTH POSITION
			with CLECs' statement of the issue or provide an alternative statement with its Response]	particular obligation does not apply.  (B) NO, CLECs are unaware of any conflicts between Attachment 2 and any other provision of the Agreement. Any conflicts that may arise or be alleged in the future should be addressed and evaluated on a case-by-case basis.	
20	2-2	1.2	<p><i>(A) Should the Agreement contain a paraphrased version of a rule regarding CLEC obligations in lieu of direct references to rules governing both Parties' obligations?</i></p> <p><i>(B) Should references to FCC rules be construed as including or excluding relevant text from the FCC's Triennial Review Order?</i></p> <p>[BellSouth will either concur with CLECs' statement of the issue or provide an alternative statement with its Response]</p>	<p>(A) NO, the Agreement should contain direct references to rules governing both Parties' obligations.</p> <p>(B) Direct references to FCC rules should be construed to include relevant text from the FCC's <i>Triennial Review Order</i>.</p>	BellSouth will provide its position with its Response.
21	2-3	1.4.2	<i>Should the provision regarding the effective billing date for Conversions explicitly state that agreement to it by</i>	YES, given that the text of this provision represents a negotiated resolution to a controversial issue that has no intended retroactive effect on ongoing disputes between the Parties, it is appropriate to	BellSouth will provide its position with its Response.

ITEM No.	ISSUE #	§	UNRESOLVED ISSUE	CLEC POSITION	BELL SOUTH POSITION
			<p><i>CLECs is made without admission or prejudice with respect to pre-existing disputes regarding this issue?</i></p> <p>[BellSouth will either concur with CLECs' statement of the issue or provide an alternative statement with its Response]</p>	include such a disclaimer in the provision.	
22	2-4	1.4.3	<p><i>(A) Should CLEC be required to submit a BFR/NBR to convert a UNE or Combination (or part thereof) to Other Services or tariffed BellSouth access services?</i></p> <p><i>(B) In the event of such conversion, what rates should apply?</i></p> <p>[BellSouth will either concur with CLECs' statement of the issue or provide an alternative statement with its Response]</p>	<p>(A) NO, CLEC should be allowed to submit an LSR or ASR, as appropriate.</p> <p>(B) For such conversion, the non-recurring charges should be as set forth in Exhibit A of Attachment 2 or the relevant tariff, as appropriate. In addition, such charges should be commensurate with the work required to effectuate the conversion (cross connect only, billing change/records update only, etc.).</p>	BellSouth will provide its position with its Response.
23	2-5	1.5	<p><i>(A) In the event UNEs or Combinations are no longer offered pursuant to, or are not in compliance with, the terms set forth in this Agreement, which Party should bear the</i></p>	<p>(A) In the event UNEs or Combinations are no longer offered pursuant to, or are not in compliance with, the terms set forth in the Agreement, it should be BellSouth's obligation to identify the specific service arrangements that it insists be transitioned to other services pursuant to Attachment 2.</p>	BellSouth will provide its position with its Response.

ITEM No.	ISSUE #	§	UNRESOLVED ISSUE	CLEC POSITION	BELL SOUTH POSITION
			<p><i>obligation of identifying those service arrangements?</i></p> <p><i>(B) What recourse may BellSouth take if CLEC does not submit a rearrange or disconnect order within 30 days?</i></p> <p><i>(C) What rates, terms and conditions should apply in the event of a termination, re-termination, or physical rearrangements of circuits?</i></p> <p>[BellSouth will either concur with CLECs' statement of the issue or provide an alternative statement with its Response]</p>	<p>(B) If CLEC does not submit a rearrange or disconnect order within 30 days, BellSouth may disconnect such arrangements or services without further notice, provided that CLEC has not notified BellSouth of a dispute regarding the identification of specific service arrangements as being no longer offered pursuant to, or are not in compliance with, the terms set forth in the Agreement.</p> <p>(C) For arrangements that require a re-termination or other physical rearrangement of circuits to comply with the terms of the Agreement, non-recurring charges for the applicable UNE or cross connect from Exhibit A of Attachment 2 should apply. Disconnect charges should not apply to services that are being physically rearranged or re-terminated.</p>	
24	2-6	1.5.1	<p><i>Should BellSouth be entitled to impose limitations on CLEC use of UNEs not permitted by Applicable Law?</i></p> <p>[BellSouth will concur with CLECs' statement of the issue or provide an alternative statement with its Response]</p>	NO, unless permitted under Applicable Law, BellSouth may not impose limitations on CLEC's ability to access and use UNEs.	BellSouth will provide its position with its Response.

ITEM No.	ISSUE #	§	UNRESOLVED ISSUE	CLEC POSITION	BELL SOUTH POSITION
25	2-7	1.6.1	<p><i>What rates, terms and conditions should apply for Routine Network Modifications pursuant to 47 C.F.R. § 51.319(a)(8) and (e)(5)?</i></p> <p>[BellSouth will either concur with CLECs' statement of the issue or provide an alternative statement with its Response]</p>	<p>If BellSouth has anticipated such Routine Network Modifications and performs them during normal operations, then BellSouth should perform such Routine Network Modifications at no additional charge. If BellSouth has not anticipated a requested or necessary network modification as being a Routine Network Modification and, as such, has not recovered the costs of such Routine Network Modifications in the rates set forth in Exhibit A of Attachment 2, then BellSouth should notify CLEC of the required Routine Network Modification and should request that CLEC submit a Service Inquiry to have the work performed. Each <i>unique</i> request should be handled as a project on an individual case basis. BellSouth should provide a TELRIC-compliant price quote for the request, and upon receipt of a firm order from CLEC, BellSouth should perform the Routine Network Modification.</p>	<p>BellSouth will provide its position with its Response.</p>
26	2-8	1.7	<p><i>Should BellSouth be required to commingle UNEs or Combinations with any service, network element or other offering that it is obligated to make available pursuant to Section 271 of the Act?</i></p>	<p>YES, BellSouth should be required to commingle UNEs or Combinations with any service, network element, or other offering that it is obligated to make available pursuant to Section 271 of the Act.</p>	<p>BellSouth will provide its position with its Response.</p>

ITEM No.	ISSUE #	§	UNRESOLVED ISSUE	CLEC POSITION	BELL SOUTH POSITION
			[BellSouth will either concur with CLECs' statement of the issue or provide an alternative statement with its Response]		
27	2-9	1.8.3	<p><i>When multiplexing equipment is attached to a commingled circuit, should the multiplexing equipment be billed per the jurisdictional authorization (Agreement or tariff) of the lower or higher bandwidth service?</i></p> <p>[BellSouth will either concur in CLECs' statement of the issue or provide an alternative statement with its Response]</p>	When multiplexing equipment is attached to a commingled circuit, the multiplexing equipment should be billed from the same jurisdictional authorization (Agreement or tariff) as the lower bandwidth service.	BellSouth will provide its position with its Response.
28	2-10	1.9.4	<p><i>Should the recurring charges for UNEs, Combinations and Other Services be prorated based upon the number of days that the UNEs are in service?</i></p> <p>[BellSouth will either concur in CLECs' statement of the issue or provide an alternative statement with its Response]</p>	YES, the recurring charges for UNEs, Combinations, and Other Services should be prorated based upon the number of days that the UNEs, Combinations, and Other Services are in service.	BellSouth will provide its position with its Response.
29	2-11	2.1.1	<i>Are the types of loops that BellSouth, pursuant to FCC Rule 319(a), is</i>	The types of loops that BellSouth is required to provide to CLEC, pursuant to FCC Rule 319(a), should be limited to those	BellSouth will provide its position with its Response.

ITEM No.	ISSUE #	§	UNRESOLVED ISSUE	CLEC POSITION	BELL SOUTH POSITION
			<p><i>required to provide to CLEC limited to those that are (a) currently available and set forth in the Agreement or (b) set forth in the Agreement?</i></p> <p>[BellSouth will either concur in CLECs' statement of the issue or provide an alternative statement with its Response]</p>	<p>that BellSouth currently offers and is required to unbundle as set forth in the Agreement. Other loop-types that may be developed and may be subject to FCC Rule 319(a) will be incorporated into the Agreement by amendment or the BFR process.</p>	
30	2-12	2.1.1.1	<p><i>Should the Agreement include a provision declaring that facilities that terminate to another carrier's switch or premises, a cell site, Mobile Switching Center or base station do not constitute loops?</i></p> <p>[BellSouth will either concur in CLECs' statement of the issue or provide an alternative statement with its Response]</p>	<p>NO, the Agreement should not include a provision declaring that facilities that terminate to another carrier's switch or premises, a cell site, Mobile Switching Center, or base station do not constitute loops. Such a provision would be inconsistent with the FCC's Triennial Review Order.</p>	<p>BellSouth will provide its position with its Response.</p>
31	2-13	2.1.1.2	<p><i>Should the Agreement require CLEC to purchase the entire bandwidth of a Loop, even in cases where such purchase is not required by Applicable Law?</i></p>	<p>NO, CLEC should not be required to purchase the entire bandwidth of a Loop, except where required by Applicable Law.</p>	<p>BellSouth will provide its position with its Response.</p>

ITEM No.	ISSUE #	§	UNRESOLVED ISSUE	CLEC POSITION	BELL SOUTH POSITION
			[BellSouth will either concur in CLECs' statement of the issue or provide an alternative statement with its Response]		
32	2-14	2.1.2, 2.1.2.1, 2.1.2.2	<p><i>(A) Should the Agreement contain provisions categorizing loops as either mass market loops or enterprise market loops?</i></p> <p><i>(B) If so, what should such provisions say?</i></p> <p>[BellSouth will either concur in CLECs' statement of the issue or provide an alternative statement with its Response]</p>	<p>(A) YES, the Agreement should contain provisions categorizing loops as either mass market loops or enterprise market loops.</p> <p>(B) Such provisions should state that there are two categories of UNE loops, namely, Mass Market Loops and Enterprise Loops. The provisions should further define Mass Market Loops as loops that deliver narrow-band service, such as POTS, facsimile services and DS0 level services as well as broadband services such as DSL services to residential and very small business customers. In addition, there should be a provision listing the three types of Mass Market Loops: copper loops, fiber-to-the-home loops, and hybrid fiber/copper loops.</p> <p>The provision should define Enterprise Market Loops as loops that deliver narrow-band and broadband services to small, medium and large-sized businesses. Similarly, there should be a provision setting forth that Enterprise Loops, including DS1, DS-3/STS loops, and dark fiber loops are not subject to any of the restrictions applicable to Mass Market Loops, regardless of the transmission</p>	BellSouth will provide its position with its Response.



ITEM No.	ISSUE #	§	UNRESOLVED ISSUE	CLEC POSITION	BELLSOUTH POSITION
				medium over which they are provided.	
33	2-15	2.2.3	<p><i>Is unbundling relief provided under FCC Rule 319(a)(3) applicable to Fiber-to-the-Home Loops deployed prior to October 2, 2003?</i></p> <p>[BellSouth will either concur in CLECs' statement of the issue or provide an alternative statement with its Response]</p>	NO, the unbundling relief provided under FCC Rule 319(a)(3) is only applicable to Fiber-to-the-Home Loops deployed <u>on or after</u> October 2, 2003 (the effective date of the FCC's Triennial Review Order).	BellSouth will provide its position with its Response.
34	2-16	2.3.3	<p><i>How should Dark Fiber Loops be defined?</i></p> <p>[BellSouth will either concur in CLECs' statement of the issue or provide an alternative statement with its Response]</p>	Dark Fiber Loop should be defined as fiber within an existing fiber optic cable that has not been activated through the use of optronics to render it capable of carrying communications services that extends from the demarcation point at an End User's premises to the BellSouth central office.	BellSouth will provide its position with its Response.
35	2-17	2.4.3, 2.4.4	<p><i>What rates should apply to testing and dispatch performed by BellSouth in response to a CLEC trouble report and in order to confirm the working status of a UNE Loop?</i></p> <p>[BellSouth will either concur in CLECs' statement of the issue or provide an alternative statement with its Response]</p>	TELRIC-compliant rates to be approved by the Commission and incorporated in Exhibit A of Attachment 2 should apply to testing and dispatch performed by BellSouth in response to a CLEC trouble report and in order to confirm the working status of a UNE Loop.	BellSouth will provide its position with its Response.

ITEM No.	ISSUE #	§	UNRESOLVED ISSUE	CLEC POSITION	BELL SOUTH POSITION
36	2-18	2.12.1	<p><i>(A) How should line conditioning be defined in the Agreement?</i></p> <p><i>(B) What should BellSouth's obligations be with respect to line conditioning?</i></p> <p>[BellSouth will either concur in CLECs' statement of the issue or provide an alternative statement with its Response]</p>	<p>(A) Line Conditioning should be defined in the Agreement as set forth in FCC Rule 47 CFR 51.319 (a)(1)(iii)(A).</p> <p>(B) BellSouth should perform line conditioning in accordance with FCC Rule 47 C.F.R. 51.319 (a)(1)(iii). Insofar as it is technically feasible, BellSouth should test and report troubles for all the features, functions, and capabilities of conditioned copper lines, and may not restrict its testing to voice transmission only.</p>	BellSouth will provide its position with its Response.
37	2-19	2.12.2	<p><i>Should the Agreement contain specific provisions limiting the availability of Line Conditioning to copper loops of 18,000 feet or less?</i></p> <p>[BellSouth will either concur in CLECs' statement of the issue or provide an alternative statement with its Response]</p>	NO, the agreement should not contain specific provisions limiting the availability of Line Conditioning to copper loops of 18,000 feet or less in length.	BellSouth will provide its position with its Response.
38	2-20	2.12.3, 2.12.4	<p><i>Under what rates, terms and conditions should BellSouth be required to perform Line Conditioning to remove bridged taps?</i></p> <p>[BellSouth will either concur in CLECs' statement of the issue or</p>	Any copper loop being ordered by CLEC which has over 6,000 feet of combined bridged tap will be modified, upon request from CLEC, so that the loop will have a maximum of 6,000 feet of bridged tap. This modification will be performed at no additional charge to CLEC. Line	BellSouth will provide its position with its Response.

ITEM No.	ISSUE #	§	UNRESOLVED ISSUE	CLEC POSITION	BELL SOUTH POSITION
			provide an alternative statement with its Response]	conditioning orders that require the removal of other bridged tap should be performed at the rates set forth in Exhibit A of Attachment 2.	
39	2-21	2.12.6	<p><i>(A) Should the Agreement contain a provision barring Line Conditioning that would result in the modification of a Loop in such a way that it no longer meets technical parameters of the original Loop?</i></p> <p><i>(B) If not, should the resulting modified Loop be maintained as a non-service -specific Unbundled Copper Loop?</i></p> <p>[BellSouth will either concur in CLECs' statement of the issue or provide an alternative statement with its Response]</p>	<p>(A) NO, CLEC should not be barred from requesting Line Conditioning that would result in the modification of a Loop in such a way that it no longer meets the technical parameters of the original Loop.</p> <p>(B) YES, the resulting modified Loop should be maintained as a non-service-specific Unbundled Copper Loop.</p>	BellSouth will provide its position with its Response.
40	2-22	2.14.3.1.1	<i>Should BellSouth be required to allow CLEC to connect its Loops directly to BellSouth's multi-line residential NID enclosures that have spare terminations available?</i>	YES, the Commission should order BellSouth to allow CLEC to connect its Loops directly to BellSouth's multi-line residential NID enclosures that have spare terminations available.	BellSouth will provide its position with its Response.

ITEM No.	ISSUE #	§	UNRESOLVED ISSUE	CLEC POSITION	BELL SOUTH POSITION
			[BellSouth will either concur in CLECs' statement of the issue or provide an alternative statement with its Response]		
41	2-23	2.16.2.2, 2.16.2.3.1-5, 2.16.2.3.7-12	<p><i>(A) Should the provisions relating to BellSouth's obligation to provide Unbundled Network Terminating Wire (UNTW) apply to CLEC, as well?</i></p> <p><i>(B) Should the obligation to provide UNTW apply when such premise wiring is leased? (2.16.2.2, 2.16.2.3.1)</i></p> <p><i>(C) Should the obligation to provide access to UNTW be limited to existing UNTW? (2.16.2.3.2)</i></p> <p><i>(D) Should CLECs have to agree to language that requires them to "ensure" that a customer that has asked to switch service to CLEC is already no longer using another carrier's service on that pair – or – will language obligating CLEC to use commercially</i></p>	<p>(A) NO, CLECs have expressly notified BellSouth that they are at the present time unwilling to negotiate such access to UNTW as CLECs have no legal obligation to make UNEs available to, or otherwise unbundle UNTW for, BellSouth.</p> <p>(B) YES, BellSouth's legal obligation to provide UNTW applies even where the premises wiring is leased.</p> <p>(C) NO, to the extent BellSouth would install new or additional UNTW beyond existing UNTW upon request from one of its own End Users, or is otherwise required to do so in order to comply with FCC or Commission rules and orders, BellSouth should be obligated to provide access to such new or additional UNTW beyond existing UNTW.</p> <p>(D) CLEC should not be required to "ensure" that a customer that has asked to switch service to CLEC is no longer using another carrier's service on a particular pair. Rather, a provision obligating CLEC to use commercially reasonable efforts to access only an "available pair" should be</p>	BellSouth will provide its position with its Response.

ITEM No.	ISSUE #	§	UNRESOLVED ISSUE	CLEC POSITION	BELL SOUTH POSITION
			<p><i>reasonable efforts to access only an “available pair” suffice? (2.16.2.3.5)</i></p> <p><i>(E) Should a time limit be placed on the obligation to reimburse costs associated with removing access terminals and restoring the property to its original state (per request of property owner)? (2.16.2.3.7)</i></p> <p>[BellSouth will either concur in CLECs’ statement of the issue or provide an alternative statement with its Response]</p>	<p>sufficient.</p> <p>(E) YES, there should be a time limit on reimbursement obligations. Specifically, CLEC should be responsible for costs associated with removing access terminals and restoring the property to its original state only when the property owner objects to and demands removal of access terminal installations that are in progress or within thirty (30) calendar days of completion.</p>	
42	2-24	2.17.3.5	<p><i>Should BellSouth be required to provide access to Dark Fiber Loops for test access and testing at any technically feasible point?</i></p> <p>[BellSouth will either concur in CLECs’ statement of the issue or provide an alternative statement with its Response]</p>	<p>YES, BellSouth should be required to provide access to Dark Fiber Loops for test access and testing at any technically feasible point, the termination point within a serving wire center, and CLEC’s End User’s premises.</p>	<p>BellSouth will provide its position with its Response.</p>

ITEM No.	ISSUE #	§	UNRESOLVED ISSUE	CLEC POSITION	BELL SOUTH POSITION
43	2-25	2.18.1.4	<p><i>Under what circumstances should BellSouth provide CLEC Loop Makeup information?</i></p> <p>[BellSouth will either concur in CLECs' statement of the issue or provide an alternative statement with its Response]</p>	<p>BellSouth should provide CLEC Loop Makeup information on a particular loop upon request by CLEC. Such access should not be contingent upon receipt of an LOA from a third party carrier.</p>	<p>BellSouth will provide its position with its Response.</p>
44	2-26	3.6.5	<p><i>When Line Sharing is provisioned, what provisions should apply when BellSouth receives a voice trouble and isolates the trouble to a physical collocation arrangement belonging to CLEC?</i></p> <p>[BellSouth will either concur in CLECs' statement of the issue or provide an alternative statement with its Response]</p>	<p>When Line Sharing is provisioned, the following provisions should apply when BellSouth receives a voice trouble and isolates the trouble to a physical collocation arrangement belonging to CLEC: When BellSouth receives a voice trouble and isolates the trouble to the physical collocation arrangement belonging to CLEC, BellSouth should notify CLEC. CLEC should respond by providing at least one (1) but no more than two (2) verbal CFA pair changes to BellSouth in an attempt to resolve the voice trouble. In the event a CFA pair change resolves the voice trouble, CLEC should provide BellSouth an LSR with the new CFA pair information within twenty-four (24) hours (excluding Saturdays, Sundays and Holidays) of receiving notification from BellSouth of such resolution. No charges should apply for submission of such LSR. If CLEC fails to respond to a BellSouth request for verbal CFA pair changes within twenty-four (24)</p>	<p>BellSouth will provide its position with its Response.</p>

ITEM No.	ISSUE #	§	UNRESOLVED ISSUE	CLEC POSITION	BELL SOUTH POSITION
				hours (excluding Saturdays, Sundays and Holidays) of CLEC's Maintenance Service Center receiving notification from BellSouth, BellSouth may suspend CLEC's access to the High Frequency Spectrum on such Loop.	
45	2-27	3.10.3	<p><i>What should be CLEC's indemnification obligations under a line splitting arrangement?</i></p> <p>[BellSouth will either concur in CLECs' statement of the issue or provide an alternative statement with its Response]</p>	If CLEC is purchasing line splitting, and it is not the data provider, CLEC should indemnify, defend and hold harmless BellSouth from and against any claims, losses, actions, causes of action, suits, demands, damages, injury, and costs (including reasonable attorney fees) reasonably arising or resulting from the actions taken by the data provider in connection with the line splitting arrangement, except to the extent caused by BellSouth's gross negligence or willful misconduct.	BellSouth will provide its position with its Response.
46	2-28	3.10.4	<p><i>(A) In cases where CLEC purchases UNEs from BellSouth, should BellSouth be required not to refuse to provide DSL transport or DSL services (of any kind) to CLEC and its End Users, unless BellSouth has been expressly permitted to do so by the Commission?</i></p>	<p>(A) YES, in cases where CLEC purchases UNEs from BellSouth, BellSouth should not refuse to provide DSL transport or DSL services (of any kind) to CLEC and its End Users, unless BellSouth has been expressly permitted to do so by the Commission.</p> <p>(B) YES, where BellSouth provides such transport or services to CLEC and its End Users, BellSouth should be required to do so without charge until such time as it produces an amendment proposal and the</p>	BellSouth will provide its position with its Response.

ITEM No.	ISSUE #	§	UNRESOLVED ISSUE	CLEC POSITION	BELL SOUTH POSITION
			<p><i>(B) Where BellSouth provides such transport or services to CLEC and its End Users, should BellSouth be required to do so without charge until such time as it produces an amendment proposal and the Parties amend this Agreement to incorporate terms that are no less favorable, in any respect, than the rates, terms and conditions pursuant to which BellSouth provides such transport and services to any other entity?</i></p> <p>[BellSouth will either concur in CLECs' statement of the issue or provide an alternative statement with its Response]</p>	<p>Parties amend this Agreement to incorporate terms that are no less favorable, in any respect, than the rates, terms and conditions pursuant to which BellSouth provides such transport and services to any other entity.</p>	
47	2-29	4.2.2	<p><i>(A) Should BellSouth be entitled to a greater limitation on its duty to unbundle Local Circuit Switching than currently prescribed by the FCC?</i></p> <p><i>(B) Should the Agreement include a provision that requires CLEC to do</i></p>	<p>(A) NO, the limitations imposed on BellSouth's duty to unbundle Local Circuit Switching should be consistent with the limitations prescribed by the FCC.</p> <p>(B) NO, to the extent the Effective Date is later than April 1, 2004, CLEC should not be required to submit orders to terminate, prior to the Effective Date, unbundled local circuit switching for CLEC when CLEC</p>	<p>BellSouth will provide its position with its Response.</p>



ITEM No.	ISSUE #	§	UNRESOLVED ISSUE	CLEC POSITION	BELLSOUTH POSITION
			<p><i>something prior to the Effective Date?</i></p> <p>[BellSouth will either concur in CLECs' statement of the issue or provide an alternative statement with its Response]</p>	<p>serves an End User with a DS1 or higher capacity Loop prior to the Effective Date.</p>	
48	2-30	4.5.5	<p><i>Should CLEC be entitled to purchase transport facilities and trunks used to connect to BellSouth's TOPS at TELRIC-compliant rates?</i></p> <p>[BellSouth will either concur in CLECs' statement of the issue or provide an alternative statement with its Response]</p>	<p>YES, CLEC should be entitled to purchase transport facilities and trunks used to connect to BellSouth's TOPS at TELRIC-compliant rates.</p>	<p>BellSouth will provide its position with its Response.</p>
49	2-31	5.2.4	<p><i>Under what conditions, if any, may BellSouth deny or delay a CLEC request to convert a circuit to a high capacity EEL?</i></p> <p>[BellSouth will either concur in CLECs' statement of the issue or provide an alternative statement with its Response]</p>	<p>BellSouth may not deny or delay CLEC's request for a high-capacity EEL based upon its own assessment of compliance with eligibility criteria. However, BellSouth may notify CLEC when it detects an order that it does not believe complies with the eligibility criteria. CLEC will then have the option of proceeding with, modifying or canceling such order.</p>	<p>BellSouth will provide its position with its Response.</p>
50	2-32	5.2.5.2.1-7	<p><i>Should the high capacity EEL eligibility criteria use the term "customer", as used in the FCC's rules, or "End User"?</i></p>	<p>The high capacity EEL eligibility criteria should be consistent with those set forth in the FCC's rules and should use the term "customer", as used in the FCC's rules. Use of the term "End User" may result in a</p>	<p>BellSouth will provide its position with its Response.</p>

ITEM No.	ISSUE #	§	UNRESOLVED ISSUE	CLEC POSITION	BELL SOUTH POSITION
			[BellSouth will either concur in CLECs' statement of the issue or provide an alternative statement with its Response]	deviation from the FCC rules to which CLECs are unwilling to agree.	
51	2-33	5.2.6, 5.2.6.1, 5.2.6.2, 5.2.6.2.1, 5.2.6.2.3	<p><i>(A) How often, and under what circumstances, should BellSouth be able to audit CLEC's records to verify compliance with the high capacity EEL service eligibility criteria?</i></p> <p><i>(B) Should there be a notice requirement for BellSouth to conduct an audit and what should the notice include?</i></p> <p><i>(C) Who should conduct the audit and how should the audit be performed?</i></p> <p>[BellSouth will either concur in CLECs' statement of the issue or provide an alternative statement with its Response]</p>	<p>(A) BellSouth may, no more frequently than on an annual basis, and only based upon cause, conduct a limited audit of CLEC's records in order to verify compliance with the high capacity EEL service eligibility criteria.</p> <p>(B) YES, to invoke its limited right to audit, BellSouth should send a Notice of Audit to CLEC, identifying the particular circuits for which BellSouth alleges non-compliance and the cause upon which BellSouth rests its allegations. The Notice of Audit should also include all supporting documentation upon which BellSouth establishes the cause that forms the basis of BellSouth's allegations of noncompliance. Such Notice of Audit should be delivered to CLEC with all supporting documentation no less than thirty (30) days prior to the date upon which BellSouth seeks to commence an audit.</p> <p>(C) The audit should be conducted by a third party independent auditor mutually agreed-upon by the Parties and retained and paid for by BellSouth. The audit should</p>	BellSouth will provide its position with its Response.

ITEM No.	ISSUE #	§	UNRESOLVED ISSUE	CLEC POSITION	BELL SOUTH POSITION
				<p>commence at a mutually agreeable location (or locations) no sooner than thirty (30) days after the parties have reached agreement on the auditor. In addition, the audit should be performed in accordance with the standards established by the American Institute for Certified Public Accountants (AICPA) which will require the auditor to perform an “examination engagement” and issue an opinion regarding CLEC’s compliance with the high capacity EEL eligibility criteria. AICPA standards and other requirements related to determining the independence of an auditor will govern the audit of requesting carrier compliance. The concept of materiality should govern this audit; the independent auditor’s report should conclude whether or the extent to which CLEC complied in all material respects with the applicable service eligibility criteria. Consistent with standard auditing practices, such audits should require compliance testing designed by the independent auditor, which typically includes an examination of a sample selected in accordance with the independent auditor’s judgment.</p>	
52	2-34	5.2.8	<p><i>When should CLEC be required to reimburse BellSouth for the cost of the independent auditor?</i></p>	<p>As expressly set forth in the FCC’s Triennial Review Order, in the event the auditor’s report concludes that CLEC did not comply in all material respects with the</p>	<p>BellSouth will provide its position with its Response.</p>

ITEM No.	ISSUE #	§	UNRESOLVED ISSUE	CLEC POSITION	BELL SOUTH POSITION
			[BellSouth will either concur in CLECs' statement of the issue or provide an alternative statement with its Response]	service eligibility criteria, CLEC shall reimburse BellSouth for the cost of the independent auditor.	
53	2-35	6.1.1	<p><i>How should Dedicated Transport be defined?</i></p> <p>[BellSouth will either concur in CLECs' statement of the issue or provide an alternative statement with its Response]</p>	<p>Dedicated Transport should be defined as set forth in 47 C.F.R. 319(e). The definition should also encompass the FCC's definition articulated in the Triennial Review Order, to wit: "Dedicated Transport is defined as BellSouth's interoffice transmission facilities, dedicated to a particular customer or carrier that CLEC uses for transmission between wire centers or switches owned by BellSouth and to the extent that BellSouth has local switching equipment, as defined by the FCC's rules, "reverse collocated" in a non-incumbent LEC premises, the transmission path from this point back to the BellSouth wire center shall be unbundled as transport between incumbent LEC switches or wire centers to the extent specified in part 51 of the FCC's rules within the same LATA."</p>	BellSouth will provide its position with its Response.
54	2-36	6.1.1.1	<p><i>How should Dark Fiber Transport be defined?</i></p> <p>[BellSouth will either concur in CLECs' statement of the issue or provide an alternative statement with its Response]</p>	Dark Fiber Transport should be defined as set forth in FCC Rule 47 CFR 319(e).	BellSouth will provide its position with its Response.

ITEM No.	ISSUE #	§	UNRESOLVED ISSUE	CLEC POSITION	BELL SOUTH POSITION
55	2-37	6.4.2	<p><i>What terms should govern CLEC access to test and splice Dark Fiber Transport?</i></p> <p>[BellSouth will either concur in CLECs' statement of the issue or provide an alternative statement with its Response]</p>	<p>CLEC should be able to splice and test Dark Fiber Transport obtained from BellSouth at any technically feasible point, using CLEC or CLEC-designated personnel. BellSouth must provide appropriate interfaces to allow splicing and testing of Dark Fiber.</p>	<p>BellSouth will provide its position with its Response.</p>
56	2-38	7.2, 7.3	<p><i>Should BellSouth's obligation to provide signaling link transport and SS7 interconnection at TELRIC-based rates be limited to circumstances in which BellSouth is required to provide and is providing to CLEC unbundled access to Local Circuit Switching?</i></p> <p>[BellSouth will either concur in CLECs' statement of the issue or provide an alternative statement with its Response]</p>	<p>NO, BellSouth's obligation to provide signaling link transport and SS7 interconnection at TELRIC-based rates should not be limited to circumstances in which BellSouth is required to provide and is providing to CLEC unbundled access to Local Circuit Switching.</p>	<p>BellSouth will provide its position with its Response.</p>
57	2-39	7.4	<p><i>Should the Parties be obligated to perform CNAM queries and pass such information on all calls exchanged between them, regardless of whether that would require</i></p>	<p>YES, the Parties should be obligated to perform CNAM queries and pass such information on all calls exchanged between them, regardless of whether that would require BellSouth to query a third party database provider.</p>	<p>BellSouth will provide its position with its Response.</p>

ITEM No.	ISSUE #	§	UNRESOLVED ISSUE	CLEC POSITION	BELL SOUTH POSITION
			<p><i>BellSouth to query a third party database provider?</i></p> <p>[BellSouth will either concur in CLECs' statement of the issue or provide an alternative statement with its Response]</p>		
58	2-40	9.3.5	<p><i>Should LIDB charges be subject to application of jurisdictional factors?</i></p> <p>[BellSouth will either concur in CLECs' statement of the issue or provide an alternative statement with its Response]</p>	No, LIDB charges should not be subject to application of jurisdictional factors.	BellSouth will provide its position with its Response.
59	2-41	14.1	<p><i>What terms should govern BellSouth's obligation to provide access to OSS?</i></p> <p>[BellSouth will either concur in CLECs' statement of the issue or provide an alternative statement with its Response]</p>	BellSouth must provide CLEC with nondiscriminatory access to operations support systems on an unbundled basis, in accordance with 47 CFR 51.319(g) and as set forth in Attachment 6. Operations support system ("OSS") functions consist of pre-ordering, ordering, provisioning, maintenance and repair, and billing functions supported by BellSouth's databases and information. BellSouth, as part of its duty to provide access to the pre-ordering function, must provide CLEC with nondiscriminatory access to the same detailed information about the loop that is available to BellSouth.	BellSouth will provide its position with its Response.

ITEM No.	ISSUE #	§	UNRESOLVED ISSUE	CLEC POSITION	BELL SOUTH POSITION
<b>INTERCONNECTION (ATTACHMENT 3)</b>					
60	3-1	3.3.4 (KMC, NSC, NVX) 3.3.3 XSP)	<p><i>Should CLEC be permitted to connect to BellSouth's switch via a Cross Connect or any other technically feasible means of interconnection?</i></p> <p>[BellSouth will either concur in CLECs' statement of the issue or provide an alternative statement with its Response]</p>	<p>YES, in the event that a Party's Point of Presence is located within any serving wire center (i.e., switch location), such Party may interconnect to the other Party's switch via a Cross Connect or any other technically feasible means of interconnection.</p>	<p>BellSouth will provide its position with its Response.</p>
61	3-2	9.6 (KMC), 9.6 (NSC), 9.6 (NVX, XSP)	<p><i>(A) Should BellSouth be required to provide upon request, for any trunk group outage that has occurred 3 or more times in a 60 day period, a written root cause analysis report?</i></p> <p><i>(B) What target interval should apply for the delivery of such reports, as well as for those for global outages?</i></p> <p>[BellSouth will either concur in CLECs' statement of the issue or provide an alternative statement with its Response]</p>	<p>(A) YES, upon request, BellSouth should provide a written root cause analysis report for all global outages, and for any trunk group outage that has occurred 3 or more times in a 60 day period.</p> <p>(B) BellSouth should use best efforts to provide global outage and trunk group outage root cause analysis reports within five (5) business days of request.</p>	<p>BellSouth will provide its position with its Response.</p>
62	3-3	10.9.5 (KMC),	<p><i>What provisions should apply regarding records</i></p>	<p>In the event that either Party fails to provide accurate switched access detailed usage data</p>	<p>BellSouth will provide its position with its Response.</p>

ITEM No.	ISSUE #	§	UNRESOLVED ISSUE	CLEC POSITION	BELL SOUTH POSITION
		10.7.4 (NSC), 10.7.4 (NVX), 10.12.4 (XSP)	<i>exchange necessary for the billing and collection of access revenues?</i>  [BellSouth will either concur in CLECs' statement of the issue or provide an alternative statement with its Response]	to the other Party <i>within 90 days</i> after the recording date and the receiving Party is unable to bill and/or collect access revenues due to the sending Party's failure to provide such data within said time period, then the Party failing to send the specified data should be liable to the other Party in an amount equal to the unbillable or uncollectible revenues	
63	3-4	10.10.6 (KMC), 10.8.6 (NSC), 10.8.6 (NVX), 10.13.5 (XSP)	<i>Under what terms should CLEC be obligated to reimburse BellSouth for amounts BellSouth pays to third party carriers that terminate BellSouth transited/CLEC originated traffic?</i>  [BellSouth will either concur in CLECs' statement of the issue or provide an alternative statement with its Response]	In the event that a terminating third party carrier imposes on BellSouth any charges or costs for the delivery of Transit Traffic originated by CLEC, CLEC should reimburse BellSouth for all charges paid by BellSouth, which BellSouth is contractually obligated to pay.  BellSouth should diligently review, dispute and pay such third party invoices (or equivalent) in a manner that is at parity with its own practices for reviewing, disputing and paying such invoices (or equivalent) when no similar reimbursement provision applies.	BellSouth will provide its position with its Response.
64	3-5	10.7.4.2 (KMC), 10.5.5.2 (NSC), 10.5.6.2 (NVX)	<i>While a dispute over jurisdictional factors is pending, should factors reported by the originating party remain in place, unless the parties mutually agree otherwise?</i>	YES, in the event that negotiations and audits fail to resolve disputes between the Parties, either Party may seek Dispute Resolution as set forth in the General Terms and Conditions. While such a dispute is pending, factors reported by the originating Party should remain in place, unless the	BellSouth will provide its position with its Response.



ITEM No.	ISSUE #	§	UNRESOLVED ISSUE	CLEC POSITION	BELL SOUTH POSITION
			[BellSouth will either concur in CLECs' statement of the issue or provide an alternative statement with its Response]	Parties mutually agree otherwise.	
65	3-6	10.10.1 (KMC), 10.8.1 (NSC)	<p><i>Should BellSouth be able to impose upon CLEC a Tandem Intermediary Charge for the transport and termination of Local Transit Traffic and ISP-Bound Transit Traffic?</i></p> <p>[BellSouth will either concur in CLECs' statement of the issue or provide an alternative statement with its Response]</p>	NO, BellSouth should not be permitted to impose upon CLEC a Tandem Intermediary Charge ("TIC") for the transport and termination of Local Transit Traffic and ISP-Bound Transit Traffic. The TIC is a non-TELRIC based additive charge which exploits BellSouth's market power and is discriminatory.	BellSouth will provide its position with its Response.
66	3-7	10.1 (KMC), 10.1 (XSP)	<p><i>Should CLEC be entitled to symmetrical reciprocal compensation for the transport and termination of Local Traffic at the tandem interconnection rate?</i></p> <p>[BellSouth will either concur in CLECs' statement of the issue or provide an alternative statement with its Response]</p>	YES, CLEC should be entitled to bill, and BellSouth should be obligated to pay, reciprocal compensation for the transport and termination of Local Traffic to CLEC at a symmetrical tandem interconnection rate, inclusive of end office switching, tandem switching, and transport.	BellSouth will provide its position with its Response.
67	3-8	10.2, 10.2.1 (KMC), 10.2, 10.3	<p><i>Should compensation for the transport and termination of ISP-bound Traffic be subject to a cap?</i></p>	NO, compensation caps set in the FCC's remanded ISP Order on Remand do not extend beyond 2003.	BellSouth will provide its position with its Response.

ITEM No.	ISSUE #	§	UNRESOLVED ISSUE	CLEC POSITION	BELL SOUTH POSITION
		(XSP)	[BellSouth will either concur in CLECs' statement of the issue or provide an alternative statement with its Response]		
68	3-9	2.1.12 (XSP)	<p><i>How should Local Traffic be defined?</i></p> <p>[BellSouth will either concur in CLECs' statement of the issue or provide an alternative statement with its Response]</p>	Local Traffic should be defined as any telephone call that originates in one exchange and is terminated in either the same exchange, or other mandatory local calling area associated with the originating exchange (e.g., mandatory Extended Area Service) as defined and specified in Section A3 of BellSouth's GSST. Designation of Local Traffic should not be dependent on the type of switching technology used to switch and terminate such Local Traffic, including use of frame switching. Local Traffic includes any cross boundary, intrastate, interLATA or interstate, interLATA calls established as a local call by the ruling regulatory body.	
69	3-10	3.2 (XSP), Ex. A (XSP)	<p><i>(A) Should BellSouth be required to provide CLEC with OCn level interconnection at TELRIC-compliant rates?</i></p> <p><i>(B) What should those rates be?</i></p> <p>[BellSouth will either concur in</p>	<p>(A) YES, OCn level interconnection is technically feasible and must be made available at TELRIC-compliant rates.</p> <p>(B) TELRIC compliant rates for OCn interconnection trunks and facilities should be set by the Commission.</p>	BellSouth will provide its position with its Response.

ITEM No.	ISSUE #	§	UNRESOLVED ISSUE	CLEC POSITION	BELLSOUTH POSITION
			CLECs' statement of the issue or provide an alternative statement with its Response]		
70	3-11	3.3.1, 3.3.2, 3.4.5, 10.10.2 (XSP)	<i>Should cost-based interconnection (i.e., TELRIC), be limited to the percentage of facilities used for "local" traffic?</i>  [BellSouth will either concur in CLECs' statement of the issue or provide an alternative statement with its Response]	NO, cost-based interconnection should not be limited to the percentage of facilities used for "local" traffic ("PLF"). CLEC is entitled to cost based interconnection for telephone exchange and exchange access traffic.	BellSouth will provide its position with its Response.
71	3-12	4.5 (XSP)	<i>What rate should apply in the event that a rate is not set forth in Exhibit A?</i>  [BellSouth will either concur in CLECs' statement of the issue or provide an alternative statement with its Response]	To the extent a rate associated with interconnection trunks and facilities is not set forth in Exhibit A of Attachment 3, and no Commission-approved rate has been set, the rate should be negotiated by the Parties.	BellSouth will provide its position with its Response.
72	3-13	4.6 (XSP)	<i>Should the costs of two-way interconnection trunks facilities be split (a) proportionally based on the percentage of traffic originated by each Party or (b) in half?</i>  [BellSouth will either concur in CLECs' statement of the issue or provide an alternative statement with its Response]	For two-way trunk groups that carry only both Parties' non-transit and non-interLATA Switched Access Traffic, each Party should pay its proportionate share of the recurring charges for trunks and associated facilities and nonrecurring charges for additional trunks and associated facilities based on the percentage of the total traffic originated by that Party. The Parties should determine the applicable percentages twice per year based on the previous six months minutes of use billed	BellSouth will provide its position with its Response.

ITEM No.	ISSUE #	§	UNRESOLVED ISSUE	CLEC POSITION	BELL SOUTH POSITION
				by each Party. Each Party should pay its proportionate share of initial facilities based on the joint forecasts for circuits required by each Party.	
73	3-14	10.10.4, 10.10.5, 10.10.6, 10.10.7 (XSP)	<p><i>Should CLEC be permitted to bill BellSouth based on actual traffic measurements, in lieu of BellSouth-reported jurisdictional factors?</i></p> <p>[BellSouth will either concur in CLECs' statement of the issue or provide an alternative statement with its Response]</p>	YES, where CLEC has message recording technology that identifies the jurisdiction of traffic terminated as defined in the Agreement, CLEC should have the option of using that information to bill BellSouth based upon actual measurements and jurisdictionalization, in lieu of factors reported by BellSouth.	BellSouth will provide its position with its Response.
<b>COLLOCATION (ATTACHMENT 4)</b>					
74	4-1	3.9	<p><i>What definition of "Cross Connect" should be included in the Agreement?</i></p> <p>[BellSouth will either concur in CLECs' statement of the issue or provide an alternative statement with its Response]</p>	The following definition of "Cross Connect" should be included in the Agreement: "A cross-connection (Cross Connect) is a cabling scheme between cabling runs subsystems, and equipment using patch cords or jumper wires that attach to connection hardware on each end, as defined and described by the FCC in its applicable rules and orders." In addition to the FCC's definition, the following language should be added for clarity: "A Cross Connect involved in the provision of services not associated with a collocation arrangement is not ordered but is a part of the provisioning of the service."	BellSouth will provide its position with its Response.

ITEM No.	ISSUE #	§	UNRESOLVED ISSUE	CLEC POSITION	BELL SOUTH POSITION
75	4-2	5.21.1, 5.21.2	<i>With respect to interference and impairment issues raised outside of the scope of the FCC Rule 51.233 (which relates to the deployment of Advanced Services equipment) what provisions should be included in the Agreement?</i>	<p>Provisions should be included to cover the installation and operation of any equipment or services that (1) significantly degrades (“significantly degrades” is as in the FCC rule applicable to Advanced Services); (2) endangers or damages the equipment or facilities of any other telecommunications carrier collocated in the Premises; or (3) knowingly and unlawfully compromises the privacy of communications routed through the Premises; and (4) creates an unreasonable risk of injury or death to any individual or to the public.</p> <p>The Agreement also should provide that if BellSouth reasonably determines that any equipment or facilities of CLEC violates the provisions of Section 5.21, BellSouth should provide written notice to CLEC requesting that CLEC cure the violation within forty-eight (48) hours of actual receipt of written notice or, at a minimum, to commence curative measures within twenty-four (24) hours and to exercise reasonable diligence to complete such measures as soon as possible thereafter.</p> <p>The Agreement also should state that, with the exception of instances which pose an immediate and substantial threat of physical damage to property or injury or death to any</p>	BellSouth will provide its position with its Response.

ITEM No.	ISSUE #	§	UNRESOLVED ISSUE	CLEC POSITION	BELL SOUTH POSITION
				person, disputes regarding the source of the risk, impairment, interference, or degradation should be resolved pursuant to the Dispute Resolution provisions set forth in the General Terms and Conditions.	
76	4-3	8.1	<p><i>Where grandfathering is appropriate, which rates should apply?</i></p> <p>[BellSouth will either concur in CLECs' statement of the issue or provide an alternative statement with its Response]</p>	When rates have been "grandfathered," the rates that will apply are those rates that were in effect prior to the Effective Date of the Agreement, unless application of such rates would be inconsistent with the underlying purpose for grandfathering.	BellSouth will provide its position with its Response.
77	4-4	8.4	<p><i>When should BellSouth commence billing of recurring charges for power?</i></p> <p>[BellSouth will either concur in CLECs' statement of the issue or provide an alternative statement with its Response]</p>	Billing for recurring charges for power provided by BellSouth should commence on the date upon which the primary and redundant connections from CLEC's equipment in the Collocation Space to the BellSouth power board or BDFB are installed.	Billing for power provided by BellSouth should commence on the Space Acceptance Date or the Space Ready Date if a Space Acceptance inspection does not occur within 15 calendar days of the Space Ready Date.
78	4-5	8.6	<p><i>Should CLEC be required to pay space preparation fees and charges with respect to collocations when it already has paid space preparation charges through ICB or NRC pricing?</i></p>	NO, space preparation fees should not apply when CLEC already has paid space preparation charges through previously billed ICB or non-recurring space preparation charges.	BellSouth will provide its position with its Response.

ITEM No.	ISSUE #	§	UNRESOLVED ISSUE	CLEC POSITION	BELL SOUTH POSITION
			[BellSouth will either concur in CLECs' statement of the issue or provide an alternative statement with its Response]		
79	4-6	8.11, 8.11.1, 8.12.2	<p><i>What rates should apply for BellSouth-supplied DC power?</i></p> <p>[BellSouth will either concur in CLECs' statement of the issue or provide an alternative statement with its Response]</p>	<p>Applicable rates should vary depending on whether_CLEC elects to be billed on a “fused amp” basis, by electing to remain (or install new collocations or augments) under the traditional collocation power billing method, or on a “used amp” basis, by electing to convert collocations to (or install new collocations or augments under) the power usage metering option set forth in Section 9 of Attachment 4.</p> <p>Under either billing method, there will be rates applicable to grandfathered collocations for which power plant infrastructure costs have been prepaid under an ICB pricing or non-recurring charge arrangement, and there will be rates applicable where such grandfathering does not apply and power plant infrastructure is instead recovered via recurring charges, as currently set by the Commission.</p> <p>Under the fused amp billing option, CLEC will be billed at the Commission’s most recently approved fused amp recurring rate for DC power. However, if certain arrangements are grandfathered as a result</p>	BellSouth will provide its position with its Response.

ITEM No.	ISSUE #	§	UNRESOLVED ISSUE	CLEC POSITION	BELLSOUTH POSITION
				<p>of CLEC having paid installation costs under an ICB or non-recurring rate schedule for the collocation arrangement power installation, CLEC should only be billed the recurring rate for the DC power in effect prior to the Effective Date of this Agreement, or, if rates that excluded the infrastructure component had not been incorporated into the Parties' most recent Agreement, the most recent Commission approved rate that does not include an infrastructure component should apply.</p> <p>Under the power usage metering option, recurring charges for DC power are subdivided into a power infrastructure component and an AC usage component (based on DC amps consumed). However, if certain arrangements are grandfathered as a result of CLEC having paid installation costs under an ICB or non-recurring rate schedule for the collocation arrangement power installation, CLEC should only be billed a recurring rate for the AC usage based on the most recent Commission approved rate exclusive of an infrastructure component (as set by the Commission).</p>	
80	4-7	9.1.1	<i>Under the fused amp billing option, how will recurring and non-recurring charges be</i>	Under the fused amp billing option, monthly recurring charges for -48V DC power should be assessed per fused amp per month in a manner consistent with	BellSouth will provide its position with its Response.



ITEM No.	ISSUE #	§	UNRESOLVED ISSUE	CLEC POSITION	BELL SOUTH POSITION
			<p><i>applied and what should those charges be?</i></p> <p>[BellSouth will either concur in CLECs' statement of the issue or provide an alternative statement with its Response]</p>	<p>Commission orders and as set forth in Section 8 of Attachment 4 (see Issue 4-6 above).</p> <p>Non-recurring charges for -48V DC power distribution, should be as prescribed by the Commission.</p>	
81	4-8	9.1.2, 9.1.3	<p><i>(A) Should CLEC be permitted to choose between a fused amp billing option and a power usage metering option in states other than and in addition to Tennessee (where the choice already is available)?</i></p> <p><i>(B) Under the power usage metering option, how will recurring and non-recurring charges be applied and what should those charges be?</i></p> <p>[BellSouth will either concur in CLECs' statement of the issue or provide an alternative statement with its Response]</p>	<p>(A) YES, CLEC should be permitted to choose between a fused amp billing option and a power usage metering option in states other than and in addition to Tennessee.</p> <p>(B) If CLEC chooses the power usage metering option, monthly recurring charges for -48V DC power will be assessed based on a consumption component and, if applicable, an infrastructure component, as set forth in Section 8 of Attachment 4 (see Issue 4-6 above). The Commission should ensure that its most recently approved recurring rates are apportioned appropriately into the consumption and infrastructure components.</p> <p>Non-recurring charges for -48V DC power distribution should be as prescribed by the Commission.</p>	BellSouth will provide its position with its Response.
82	4-9	9.3	<p><i>For BellSouth-supplied AC power, should CLEC be entitled to choose between</i></p>	<p>YES, where CLEC elects to install its own DC Power Plant, and BellSouth provides Alternating Current (AC) power to feed</p>	BellSouth will provide its position with its Response.

ITEM No.	ISSUE #	§	UNRESOLVED ISSUE	CLEC POSITION	BELL SOUTH POSITION
			<p><i>a fused amp billing option and a power usage metering option?</i></p> <p>[BellSouth will either concur in CLECs' statement of the issue or provide an alternative statement with its Response]</p>	<p>CLEC's DC Power Plant, CLEC should have the option of choosing between fused amp billing and power usage metering options.</p>	
83	4-10	13.6	<p><i>(A) Should BellSouth have the right to request the removal from BellSouth's Premises of a CLEC employee where the CLEC employee has not been found to have interfered with the property or personnel of BellSouth or another telecommunications carrier in a significant and material way?</i></p> <p><i>(B) In instances where interference caused by CLEC employee has not been found to have interfered with the property or personnel of BellSouth or another telecommunications carrier in a significant and material way, should the</i></p>	<p>(A) NO, only in cases where CLEC employee is found interfering with the property or personnel of BellSouth or another telecommunications carrier in a significant and material way should BellSouth be entitled to request prompt removal and suspension of access from BellSouth's Premises for any employee of CLEC to whom BellSouth does not wish to grant access pursuant to an investigation to be conducted by BellSouth.</p> <p>(B) YES, in instances where interference caused by CLEC employee has not been found to have interfered with the property or personnel of BellSouth or another telecommunications carrier in a significant and material way, the Parties should be required to cooperate and communicate, to the extent circumstances permit, to ensure that the Parties may take appropriate remedial measures and so that CLEC personnel are not denied access for activity that does not have a significant and material</p>	<p>BellSouth will provide its position with its Response.</p>

ITEM No.	ISSUE #	§	UNRESOLVED ISSUE	CLEC POSITION	BELL SOUTH POSITION
			<p><i>Parties be required to cooperate to ensure that appropriate remedial measures are taken that are less likely to have a significant impact on CLEC's daily operations?</i></p> <p>[BellSouth will either concur in CLECs' statement of the issue or provide an alternative statement with its Response]</p>	<p>impact and that would be more suitably addressed through disciplinary measures less likely to have a significant impact on CLEC's daily operations.</p>	
<b>ORDERING (ATTACHMENT 6)</b>					
84	6-1	2.5.1	<p><i>Should payment history be included in the CSR?</i></p>	<p>YES, the subscribers' payment history should be included in the CSR to the extent authorized or required by the FCC, Commission or End User.</p>	<p>NO, payment history should be maintained as confidential information and is not necessary in order for a CLEC to provision service to an end user. BellSouth's systems will not permit this information to be shared on an end user by end user or CLEC by CLEC basis.</p>
85	6-2	2.5.5	<p><i>Should CLEC have to provide BellSouth with access to CSRs within firm intervals?</i></p>	<p>NO, CLEC is not required by law to commit to specific intervals, and does not have any automated system in place to handle CSR requests. Moreover, BellSouth refuses to commit to deliver CSRs within a firm interval. CLEC, however, will commit to use its best efforts to provide CSRs within an average of 5 business days of a valid request, subject to the same exclusions applicable to BST's delivery of CSRs.</p>	<p>YES, BellSouth is required to provide CSRs to CLEC in intervals prescribed by this Commission which, if not met, require BellSouth to remit SEEMs penalties. If CLEC is not held to the same standard, the End User customer is impaired by being unable to receive the same service interval from all local service providers.</p>

ITEM No.	ISSUE #	§	UNRESOLVED ISSUE	CLEC POSITION	BELL SOUTH POSITION
86	6-3	2.5.6.2, 2.5.6.3	<p><i>(A) What procedures should apply when one Party alleges, via written notice, that the other Party has engaged in unauthorized access to CSR information?</i></p> <p><i>(B) How should disputes over alleged unauthorized access to CSR information be handled under the Agreement?</i></p>	<p>(A) Either Party, in the event it suspects that the other Party has accessed CSR information without having obtained the proper End User authorization, should send written notice to the other Party specifying the alleged noncompliance. The Party receiving the notice should be obligated to acknowledge receipt of the notice as soon as practicable, and provide appropriate proof of authorization within seven (7) days or provide notice that appropriate corrective measures have been taken or will be taken as soon as practicable.</p> <p>(B) If one Party disputes the other Party's assertion of non-compliance, that Party should notify the other Party in writing of the basis for its assertion of compliance. If the receiving Party fails to provide the other Party with notice that appropriate corrective measures have been taken within a reasonable time or provide the other Party with proof sufficient to persuade the other Party that it erred in asserting the non-compliance, the requesting Party should proceed pursuant to the Dispute Resolution provisions set forth in the General Terms and Conditions and the Parties should cooperatively seek expedited resolution of the dispute. "Self help", in the form of suspension of access to ordering systems</p>	<p>(A) The Party receiving such notice should provide documentation within seven (7) business days to prove authorization.</p> <p>(B) The Party providing notice of such impropriety should provide notice to the offending Party that additional applications for service may be refused, that any pending orders for service may not be completed, and/or that access to ordering systems may be suspended if such use is not corrected or ceased by the fifth (5<sup>th</sup>) calendar day following the date of the notice. In addition, the alleging Party may, at the same time, provide written notice to the person(s) designated by the other Party to receive notices of noncompliance that the alleging Party may terminate the provision of access to ordering systems to the other Party and may discontinue the provisioning of existing services if such use is not corrected or ceased by the tenth (10<sup>th</sup>) calendar day following the date of the initial notice. If the other Party disagrees with the alleging Party's allegations of unauthorized use, the other Party shall proceed pursuant to the dispute resolution provisions set forth in the General Terms and Conditions.</p>

ITEM No.	ISSUE #	§	UNRESOLVED ISSUE	CLEC POSITION	BELLSOUTH POSITION
				and discontinuance of service, is inappropriate and coercive. Moreover, it effectively denies one Party the ability to avail itself to the Dispute Resolution process otherwise agreed to by the Parties.	
87	6-4	2.6	<i>Should BellSouth be allowed to assess manual service order charges on CLEC orders for which BellSouth does not provide an electronic ordering option?</i>	NO, if, at any time, electronic interfaces are not available to make placement of an electronic LSR possible, CLEC must use the manual LSR process for the ordering of UNEs and Combinations. In such cases where CLEC does not willfully choose to use the manual LSR process, CLEC should be assessed the lower electronic LSR OSS rate.	YES, BellSouth is not required to provide electronic ordering capability for every function. BellSouth has implemented the Change Control Process for CLEC requests to change BellSouth's OSS capabilities if CLEC is not satisfied with existing ordering capabilities.
88	6-5	2.6.5	<i>What rate should apply for Service Data Advancement (a/k/a service expedites)?</i>	Rates for Service Date Advancement (a/k/a service expedites) related to UNEs, interconnection or collocation should be set consistent with TELRIC pricing principles.	BellSouth is not required to provide expedited service pursuant to The Act. If BellSouth elects to offer expedite capability as an enhancement to a CLEC, BellSouth's tariffed rates for service date advancement should apply.
89	6-6	2.6.25	<i>Should CLEC be required to deliver a FOC to BellSouth for purposes of porting a number within a firm interval?</i>	NO, CLEC is not required by law to commit to specific intervals, and does not have the necessary automated system in place to meet such requirements. Moreover, BellSouth refuses to commit to deliver FOCs within a firm interval. CLEC, however, subject to the same exclusions that apply to BellSouth's delivery of a FOC, is willing to commit to use best efforts to return a FOC to BellSouth, for purposes of porting a number, within an average of 5	YES, BellSouth is required to provide FOCs to CLEC in intervals prescribed by this Commission, which if not met require BellSouth to remit SEEMs penalties. If CLEC is not held to the same standard, the End User customer is impaired by being unable to receive the same service interval from all Local service providers.

ITEM No.	ISSUE #	§	UNRESOLVED ISSUE	CLEC POSITION	BELLSOUTH POSITION
				business days, for noncomplex orders, after CLEC's receipt from BellSouth of a valid LSR.	
90	6-7	2.6.26	<i>Should CLEC be required to provide Reject Responses to BellSouth within a firm interval?</i>	NO, CLEC is not required by law to commit to specific intervals, and does not have the necessary automated system in place to meet such requirements. Moreover, BellSouth refuses to commit to deliver Reject Responses within a firm interval. CLEC, however, subject to the same exclusions that apply to BellSouth's delivery of Reject Responses, is willing to commit to use best efforts to return Reject Responses to BellSouth, for purposes of porting a number, within an average of 5 business days, for noncomplex orders, after CLEC's receipt from BellSouth of a valid LSR.	YES, BellSouth is required to provide FOC Reject Responses to CLEC in intervals prescribed by this Commission which if not met require BellSouth to remit SEEMs penalties. If CLEC is not held to the same standard, the End User customer is impaired by being unable to receive the same service interval from all Local service providers.
91	6-8	2.7.10.4	<i>Should BellSouth be required to provide performance and maintenance history for circuits with chronic problems?</i>	YES, upon request from CLEC, BellSouth should disclose all available performance and maintenance history regarding the network element, service or facility subject to the chronic trouble ticket.	NO, network performance and maintenance history is BellSouth's proprietary information.
92	6-9	2.9.1	<i>Should charges for substantially similar OSS functions performed by the parties be reciprocal?</i>	YES, the Parties should bill each other OSS rates pursuant to the terms, conditions and rates for OSS as set forth in Exhibit A of Attachment 2 of the Agreement, for substantially similar OSS functions performed by the Parties.	YES, but only for those functions that CLEC performs that are substantially similar to those performed by BellSouth and only if the CLEC performs the same OSS functions pursuant to the terms and conditions under which BellSouth bills CLEC for OSS, including FOC

ITEM No.	ISSUE #	§	UNRESOLVED ISSUE	CLEC POSITION	BELL SOUTH POSITION
					turnaround times the same as BellSouth's, due date intervals the same as BellSouth's and CSRs handled under the same terms and conditions under which BellSouth provides the CSRs to CLEC.
93	6-10	3.1.1	<p><i>(A) Can Bellsouth make the porting of an End User to the CLEC contingent on either the CLEC having an operating, billing and/or collection arrangement with any third party carrier, including BellSouth Long Distance or the End User changing its PIC?</i></p> <p><i>(B) If not, should BellSouth be subject to liquidated damages for imposing such conditions?</i></p>	<p>(A) NO, BellSouth is required by law to port a customer once the customer requests to be switched to another local service provider, regardless of any arrangement or agreement (or lack thereof) between CLEC and BellSouth Long Distance or another third party carrier. BellSouth's practice represents an anticompetitive leveraging of its ILEC status in favor of, and in collusion with, its Section 272 affiliate. More specifically, BellSouth may not condition its compliance with these obligations under the Agreement upon CLEC's or its End-Users' entry into any billing and/or collection arrangement, operational understanding, relationship or other arrangement with one or more of BellSouth's Affiliates, and/or any third party carrier.</p> <p>(B) YES, liquidated damages are appropriate in this instance because it would be impossible or commercially impracticable to ascertain and fix the actual amount of damages as would be sustained by CLEC as a result of such action by</p>	<p>(A) YES. If another carrier restricts the conditions under which that carrier's end user can retain a PIC, CLEC should be required to either comply with that carriers requirements or transfer the end-user with another PIC.</p> <p>(B) NO, liquidated damages provisions are inappropriate.</p>

ITEM No.	ISSUE #	§	UNRESOLVED ISSUE	CLEC POSITION	BELL SOUTH POSITION
				<p>BellSouth. A liquidated damage amount of \$1,000 per occurrence per day is a reasonable approximation of the damages likely to be sustained by CLEC, upon the occurrence and during the continuance of any such breach. Liquidated damages should be in addition to and without prejudice to or limitation upon any other rights or remedies CLEC and/or any of its End Users may have under this Agreement and/or other applicable documents against BellSouth.</p>	
94	6-11	3.1.2, 3.1.2.1	<p><i>(A) Should the mass migration of customer service arrangements resulting from mergers, acquisitions and asset transfers be accomplished by the submission of an electronic LSR or spreadsheet?</i></p> <p><i>(B) If so, what rates should apply?</i></p> <p><i>(C) What should be the interval for such mass migrations of services?</i></p>	<p>(A) YES, mass migration of customer service arrangements (e.g., UNEs, Combinations, resale) should be accomplished pursuant to submission of electronic LSR or, if mutually agreed to by the Parties, by submission of a spreadsheet in a mutually agreed-upon format. Until such time as an electronic LSR process is available, a spreadsheet containing all relevant information should be used.</p> <p>(B) An electronic OSS charge should be assessed per service arrangement migrated. In addition, BellSouth should only charge CLEC a TELRIC-based records change charge, as set forth in Exhibit A of Attachment 2, for migrations of customers for which no physical re-termination of circuits must be performed. Similarly,</p>	<p>(A) No, each and every Merger, Acquisition and Asset Transfer is unique and requires project management and planning to ascertain the appropriate manner in which to accomplish the transfer, including how orders should be submitted. The vast array of services that may be the subject of such a transfer, under the agreement and both state and federal tariffs, necessitates that various forms of documentation may be required.</p> <p>(B) The rates by necessity must be negotiated between the Parties based upon the particular services to be transferred and the work involved.</p> <p>(C) No finite interval can be set to cover all potential situations. While shorter intervals can be committed to</p>



ITEM No.	ISSUE #	§	UNRESOLVED ISSUE	CLEC POSITION	BELL SOUTH POSITION
				<p>BellSouth should only charge CLEC a TELRIC-based charge, as set forth in Exhibit A of Attachment 2, for migrations of customers for which physical re-termination of circuits is required.</p> <p>(C) Migrations should be completed within ten (10) calendar days of an LSR or spreadsheet submission.</p>	<p>and met for small, simple projects, larger and more complex projects require much longer intervals and prioritization and cooperation between the Parties.</p>
<b>BILLING (ATTACHMENT 7)</b>					
95	7-1	1.1.3	<p><i>Should there be a time limit on the parties' ability to engage in backbilling?</i></p> <p>[BellSouth does not concur in this statement of the issue]</p>	<p>YES, bills for service should not be rendered more than ninety (90) calendar days have passed since the bill date on which those charges ordinarily would have been billed. Billed amounts for services rendered more than one (1) billing period prior to the Bill Date should be invalid unless the billing Party identifies such billing as "back-billing" on a line-item basis. Billing beyond (90) calendar days and up to a limit of six (6) months after the date upon which the bill ordinarily would have been issued may be allowed under the following conditions: (1) charges connected with jointly provided services whereby meet point billing guidelines require either Party to rely on records provided by a third party and such records have not been provided in a timely manner; and (2) charges incorrectly billed due to erroneous information supplied by the non-billing Party.</p>	<p>BellSouth Issue Statement: <i>What limitations period should apply to charges under the agreement and should such limitations period apply to all issue related to billing under the agreement?</i></p> <p>BellSouth Position: All charges incurred under the agreement should be subject to the state's statute of limitations or applicable Commission rules. Back-billing alone should not be subject to a shorter limitations period than any other claims related to billing under the agreement.</p>

ITEM No.	ISSUE #	§	UNRESOLVED ISSUE	CLEC POSITION	BELL SOUTH POSITION
96	7-2	1.2.2	<p><i>(A) What charges, if any, should be imposed for records changes made by the Parties to reflect changes in corporate names or other LEC identifiers such as OCN, CC, CIC and ACNA?</i></p> <p><i>(B) What intervals should apply to such changes?</i></p> <p>[BellSouth will either concur in CLECs' statement of the issue or provide an alternative statement with its Response]</p>	<p>(A) A Party should be entitled to make one (1) "LEC Change" (<i>i.e.</i>, corporate name change, OCN, CC, CIC, ACNA change) per state in any twelve (12) month period without charge by the other Party for updating its databases, systems and records solely to reflect such change. For any additional LEC Changes, TELRIC compliant rates should be charged.</p> <p>(B) "LEC Changes" should be accomplished in thirty (30) calendar days and should result in no delay or suspension of ordering or provisioning of any element or service provided pursuant to this Agreement, or access to any pre-order, order, provisioning, maintenance or repair interfaces. At the request of a Party, the other Party should establish a new BAN within ten (10) calendar days.</p>	BellSouth will provide its position with its Response.
97	7-3	1.4	<i>When should payment of charges for service be due?</i>	Payment of charges for services rendered should be due thirty (30) calendar days from receipt or website posting of a complete and fully readable bill or within thirty (30) calendar days from receipt or website posting of a corrected or retransmitted bill in those cases where correction or retransmission is necessary for processing.	Payment for services should be due on or before the next bill date (Payment Due Date) in immediately available funds.
98	7-4	1.6	<i>(A) What interest rate should apply for late</i>	(A) The interest rate that should apply for late payments is a uniform region-wide (1)	(A) The applicable interest rate approved by each state Commission in

ITEM No.	ISSUE #	§	UNRESOLVED ISSUE	CLEC POSITION	BELLSOUTH POSITION
			<p><i>payments?</i></p> <p><i>(B) What fee should be assessed for returned checks?</i></p>	<p>percent per month.</p> <p>(B) In addition to any applicable late payment charges, a uniform region-wide \$20 fee for all returned checks should apply.</p>	<p>BellSouth's tariffs should apply.</p> <p>(B) The Commission approved rate from the GSST should apply or, in the absence of such, the amount permitted by state law.</p>
99	7-5	1.7.1	<p><i>What recourse should a Party have if it believes the other Party is engaging in prohibited, unlawful or improper use of its facilities or services, abuse of the facilities or noncompliance with the Agreement or applicable tariffs?</i></p>	<p>Each Party should have the right to suspend access to ordering systems for and to terminate particular services or access to facilities that are being used in an unlawful, improper or abusive manner. However, such remedial action should be limited to the services or facilities in question and such suspension or termination should not be imposed unilaterally by one Party over the other's written objections to or denial of such accusations. In the event of such a dispute, "self help" should not supplant the Dispute Resolution process set forth in the Agreement.</p>	<p>Each Party should have the right to suspend or terminate service in the event it believes the other party is engaging in one of these practices.</p>
100	7-6	1.7.2	<p><i>Should CLEC be required to calculate and pay past due amounts in addition to those specified in BellSouth's notice of suspension or termination for nonpayment in order to avoid suspension or termination?</i></p> <p>[BellSouth does not concur in this statement of the issue]</p>	<p>NO. If CLEC receives a notice of suspension or termination from BellSouth with a limited time to pay nondisputed past due amounts, CLEC should, in order to avoid suspension or termination, be required to pay only the amount past due as of the date of the notice and as expressly and plainly indicated on the notice. Otherwise, CLEC will risk suspension or termination due to possible calculation and timing errors.</p>	<p>BellSouth will provide its position with its Response.</p>

ITEM No.	ISSUE #	§	UNRESOLVED ISSUE	CLEC POSITION	BELLSOUTH POSITION
101	7-7	1.8.3	<i>How many months of billing should be used to determine the maximum amount of the deposit?</i>	The amount of a deposit should not exceed two month's estimated billing for new CLECs or one and one-half month's actual billing for existing CLECs (based on average monthly billings for the most recent six (6) month period). The one and one-half month's actual billing deposit limit for existing CLECs is reasonable given that balances can be predicted with reasonable accuracy and that significant portions of services are billed in advance.	The average of two (2) months of actual billing for existing customers or estimated billing for new customers, which is consistent with the telecommunications industry's standard and BellSouth's practice with its end users.
102	7-8	1.8.3.1	<i>Should the amount of the deposit BellSouth requires from CLEC be reduced by past due amounts owed by BellSouth to CLEC?</i>	YES, the amount of security due from an existing CLEC should be reduced by amounts due CLEC by BellSouth aged over thirty (30) calendar days. BellSouth may request additional security in an amount equal to such reduction once BellSouth demonstrates a good payment history, as defined in the deposit provisions of Attachment 7. This provision is appropriate given that the Agreement's deposit provisions are not reciprocal and that BellSouth's payment history with CLECs is often poor.	NO, CLEC's remedy for addressing late payment by BellSouth should be suspension/termination of service or application of interest/late payment charges similar to BellSouth's remedy for addressing late payment by CLEC.
103	7-9	1.8.6	<i>Should BellSouth be entitled to terminate service to CLEC pursuant to the process for termination due to non-payment if CLEC refuses to remit any deposit required</i>	NO, BellSouth should have a right to terminate services to CLEC for failure to remit a deposit requested by BellSouth only in cases where (a) CLEC agrees that such a deposit is required by the Agreement, or (b) the Commission has ordered payment of such deposit. A dispute over a requested	Yes, thirty (30) calendar days is a commercially reasonable time period within which CLEC should have met its fiscal responsibilities.

ITEM No.	ISSUE #	§	UNRESOLVED ISSUE	CLEC POSITION	BELLSOUTH POSITION
			<i>by BellSouth within 30 calendar days?</i>	deposit should be addressed via the Agreement's Dispute Resolution provisions and not through "self-help".	
104	7-10	1.8.7	<i>What recourse should be available to either Party when the Parties are unable to agree on the need for or amount of a reasonable deposit?</i>	If the Parties are unable to agree on the need for or amount of a reasonable deposit, either Party should be able to file a petition for resolution of the dispute and both parties should cooperatively seek expedited resolution of such dispute.	If CLEC does not agree with the amount or need for a deposit requested by BellSouth, CLEC may file a petition with the Commission for resolution of the dispute and BellSouth would cooperatively seek expedited resolution of such dispute. BellSouth shall not terminate service during the pendency of such a proceeding provided that CLEC posts a payment bond for the amount of the requested deposit during the pendency of the proceeding.
105	7-11	1.8.9	<i>Under what conditions may BellSouth seek additional security deposit from CLEC?</i>	Subject to a standard of commercial reasonableness and the standards for deposits requirements set forth in Attachment 7, BellSouth may seek an additional deposit if a material change in the circumstances of CLEC so warrants and/or gross monthly billing has increased more than 25% beyond the level most recently used to determine the level of deposit. BellSouth should not be entitled to make such additional requests based solely on increased billing more frequently than once in any six (6) month period.	BellSouth may seek additional security, subject to a standard of commercial reasonableness, if a material change in the circumstances of CLEC so warrants and/or gross monthly billing has increased beyond the level most recently used to determine the level of security deposit.
106	7-12	1.9.1	<i>To whom should BellSouth be required to send notice of suspension for</i>	Notice of suspension for additional applications for service, pending applications for service, and access to	BellSouth will provide its position with its Response.

ITEM No.	ISSUE #	§	UNRESOLVED ISSUE	CLEC POSITION	BELL SOUTH POSITION
			<p><i>additional applications for service, pending applications for service and access to BellSouth's ordering systems?</i></p> <p>[BellSouth will either concur in CLECs' statement of the issue or provide an alternative statement with its Response]</p>	<p>BellSouth's ordering systems should be sent pursuant to the requirements of Attachment 7 and also should be sent via certified mail to the individual(s) listed in the Notices provision of the General Terms and Conditions.</p>	
<b>BFR/NBR (ATTACHMENT 11)</b>					
107	11-1	1.5, 1.8.1, 1.9, 1.10	<p><i>(A) Should BellSouth be permitted to charge CLEC the full development costs associated with a BFR?</i></p> <p><i>(B) If so, how should these costs be recovered?</i></p>	<p>(A) NO, charges associated with the development of a BFR should be apportioned among CLECs who may benefit from the UNE(s).</p> <p>(B) To the extent BellSouth can charge CLEC for the development costs associated with a BFR, such costs should be assessed through non-recurring and recurring rates.</p>	<p>(A) YES, BellSouth is entitled to recover its costs in provisioning services to CLEC. Since this is a unique request that CLEC is making, CLEC should bear the full development costs.</p> <p>(B) CLEC should be obligated to pay these costs upon request that BellSouth proceed.</p>

**Attachment 1**

**Resale**

## Table of Contents

<b>1.</b>	<b>Discount Rates.....</b>	<b>3</b>
<b>2.</b>	<b>Definition of Terms.....</b>	<b>3</b>
<b>3.</b>	<b>General Provisions.....</b>	<b><u>43</u></b>
<b>4.</b>	<b>BellSouth’s Provision of Services to &lt;&lt;customer_short_name&gt;&gt; .....</b>	<b><u>87</u></b>
<b>5.</b>	<b>Maintenance of Services.....</b>	<b><u>911</u></b>
<b>6.</b>	<b>Establishment of Service .....</b>	<b><u>1011</u></b>
<b>7.</b>	<b>Discontinuance of Service .....</b>	<b><u>1112</u></b>
<b>8.</b>	<b>Operator Services (Operator Call Processing and Directory Assistance) .....</b>	<b><u>1112</u></b>
<b>9.</b>	<b>Line Information Database (LIDB).....</b>	<b><u>1516</u></b>
<b>10.</b>	<b>RAO Hosting .....</b>	<b>16</b>
<b>11.</b>	<b>Optional Daily Usage File (ODUF).....</b>	<b>16</b>
<b>12.</b>	<b>Enhanced Optional Daily Usage File (EODUF) .....</b>	<b><u>1617</u></b>
	<b>Resale Restrictions</b>	<b>Exhibit A</b>
	<b>Line Information Database (LIDB) Storage Agreement</b>	<b>Exhibit B</b>
	<b>Optional Daily Usage File (ODUF)</b>	<b>Exhibit C</b>
	<b>Enhanced Option Daily Usage File (EODUF)</b>	<b>Exhibit D</b>
	<b>Resale Discounts and Rates</b>	<b>Exhibit E</b>



## RESALE

### 1. Discount Rates

1.1 The Commission-approved discount rates applied to <<customer\_short\_name>> purchases of BellSouth Telecommunications Services for the purpose of resale shall be as set forth in Exhibit E. Such discounts have been determined by the applicable Commission to reflect the costs avoided by BellSouth when selling a service for wholesale purposes.

1.2 The telecommunications services available for purchase by <<customer\_short\_name>> for the purposes of resale to <<customer\_short\_name>>'s End Users shall be available at BellSouth's tariffed rates less the discount set forth in Exhibit E to this Agreement and subject to the exclusions and limitations set forth in Exhibit A to this Agreement.

### 2. Definition of Terms

2.1 CUSTOMER OF RECORD means the entity responsible for placing application for service; requesting additions, rearrangements, maintenance or discontinuance of service; payment in full of charges incurred such as non-recurring, monthly recurring, toll, directory assistance, etc.

2.2 RESALE means an activity wherein a certificated CLEC, such as <<customer\_short\_name>>, subscribes to the telecommunications services of BellSouth and then offers those telecommunications services to the public.

### 3. General Provisions

3.1 All of the negotiated rates, terms and conditions set forth in this Attachment pertain to the resale of BellSouth's retail telecommunications services and other services specified in this Attachment. BellSouth shall make available to <<customer\_short\_name>> for resale those telecommunications services that BellSouth is required to offer for resale pursuant to the 1996 Act and applicable FCC and Commission rules and orders. BellSouth currently makes such services available pursuant to its General Subscriber Services Tariff and Private Line Services Tariff.

3.1.1 When <<customer\_short\_name>> provides Resale service in a cross boundary area (areas that are part of the local serving area of another state's exchange) the rates, regulations and discounts for the tariffing state will apply. Billing will be from the serving state.

3.1.2 In Tennessee, if <<customer\_short\_name>> does not resell Lifeline service to any end users, and if <<customer\_short\_name>> agrees to order an appropriate

Operator Services/Directory Assistance block as set forth in BellSouth's General Subscriber Services Tariff, the discount shall be 21.56%.

- 3.1.2.1 In the event <<customer\_short\_name>> resells Lifeline service to any end user in Tennessee, BellSouth will begin applying the 16% discount rate to all services. Upon <<customer\_short\_name>> and BellSouth's implementation of a billing arrangement whereby a separate Master Account (Q-account) associated with a separate Operating Customer Number (OCN) is established for billing of Lifeline service end users, the discount shall be applied as set forth in 3.1.2 preceding for the non-Lifeline affected Master Account (Q-account).
- 3.1.2.2 <<customer\_short\_name>> must provide written notification to BellSouth within 30 days prior to either providing its own operator services/ directory services or orders the appropriate operator services/directory assistance blocking, to qualify for the higher discount rate of 21.56%.
- 3.2 <<customer\_short\_name>> may purchase resale services from BellSouth for its own use in operating its business. The resale discount will apply to those services under the following conditions:
  - 3.2.1 <<customer\_short\_name>> must resell services to other End Users.
  - 3.2.2 <<customer\_short\_name>> cannot be a CLEC for the single purpose of selling to itself.
- 3.3 <<customer\_short\_name>> will be the customer of record for all services purchased from BellSouth. Except as specified herein, BellSouth will take orders from, bill and receive payment from <<customer\_short\_name>> for said services.
- 3.4 BellSouth shall have no contact with the End User except to the extent provided for in this Agreement.
- 3.5 Nothing herein shall affect BellSouth's rights, consistent with applicable law, to:
  - (i) bill the End User for any services that the End User specifies it wishes to receive directly from BellSouth, (ii) serve directly any End User within the service area of <<customer\_short\_name>>, or (iii) market directly its own telecommunications products and services and in doing so may establish independent relationships with End Users of <<customer\_short\_name>> consistent with applicable law.
- 3.5.1 When an End User of <<customer\_short\_name>> or BellSouth elects to change his/her carrier to the other Party, both Parties agree to release the End User's service to the other Party concurrent with the due date of the service order, which shall be established based on the reasonable and non discriminatory standard interval for the End User's requested service as set forth in the BellSouth Product and Services Interval Guide.

- 3.5.2 BellSouth and <<customer\_short\_name>> will refrain from contacting an End User who has placed or whose selected carrier has placed on the End User's behalf an order to change the End User's service provider from BellSouth or <<customer\_short\_name>> to the other Party until such time that the order for service has been completed. The Parties agree to comply with any applicable FCC and Commission rules and orders with respect to contacting End Users who have elected to change telecommunications carriers.
- 3.6 Neither Party nor the End User has a property right to the telephone number or any other call number designation associated with services furnished by BellSouth, and no right to the continuance of service through any particular central office. The End User to whom a telephone number associated with services furnished by BellSouth has been assigned has the right to continue using the telephone number to receive those services unless BellSouth is required to change the telephone number in connection with the implementation of area code relief in the form of a geographic split and/or NXX change, in which case BellSouth shall have the right to change the telephone numbers, the central office designation associated with such numbers or both after providing <<customer\_short\_name>> a period of notice in accordance with the FCC's Notices of Network Change rules. Such number changes shall be done only when BellSouth deems it necessary to do so in the conduct of its business and in accordance with BellSouth practices and procedures on a reasonable and nondiscriminatory basis. Nothing in this agreement shall affect the ability of an End User to port any telephone number associated with services furnished by BellSouth to a different service provider in accordance with applicable FCC rules and industry guidelines.
- 3.7. Service is furnished subject to the condition that it will not be used for any unlawful purpose.
- 3.8. Service will be discontinued if any law enforcement agency advises that the service being used is in violation of the law.
- 3.9. BellSouth can refuse service in accordance with Section A2.2.9 of its General Subscriber Services Tariffs and Section B2.2.2 of its Private Line Services Tariffs.
- 3.10. BellSouth will cooperate with law enforcement agencies with subpoenas and court orders relating to <<customer\_short\_name>>'s End Users, pursuant to Section 6 of the General Terms and Conditions.
- 3.11. If appropriate <<customer\_short\_name>> personnel have actual knowledge that one of its End Users is utilizing a BellSouth resold telecommunications service in a manner that is not consistent with the terms and conditions of the tariff applicable to such service, <<customer\_short\_name>> will take corrective action and will discontinue provisioning of such service if not cured within thirty (30) calendar days.

- 3.12 Facilities and/or equipment utilized by BellSouth to provide service to <<customer\_short\_name>> remain the property of BellSouth.
- 3.13 White page directory listings for <<customer\_short\_name>> End Users will be provided in accordance with Section 5 of the General Terms and Conditions.
- 3.14 Service Ordering and Operational Support Systems (OSS)
- 3.14.1 <<customer\_short\_name>> must order services through resale interfaces, i.e., the Local Carrier Service Center (LCSC) and/or appropriate Complex Resale Support Group (CRSG) pursuant to this Agreement. BellSouth has developed and made available the interactive interfaces by which <<customer\_short\_name>> may submit a Local Service Request (LSR) electronically as set forth in Attachment 2 of this Agreement. Service orders will be in a reasonable standard format designated by BellSouth and will be required on a nondiscriminatory basis.
- 3.14.2 LSRs submitted by means of one of these interactive interfaces will incur an OSS electronic charge as set forth in Exhibit E to this Attachment 1. An individual LSR will be identified for billing purposes by its Purchase Order Number (PON). LSRs submitted by means other than one of these interactive interfaces (Mail, fax, courier, etc.) will incur a manual order charge as set forth in Exhibit E to this Attachment 1. Supplements or clarifications to a previously billed LSR will not incur an additional OSS charge over and above the original OSS charge.
- 3.14.3 Denial/Restoral OSS Charge. In the event <<customer\_short\_name>> provides a list of customers to be denied and restored, rather than an LSR, each location on the list will require a separate PON and therefore will be billed as one LSR per location.
- 3.14.4 Cancellation OSS Charge. <<customer\_short\_name>> will incur an OSS charge for an accepted LSR that is later canceled.
- 3.16 BellSouth shall provide 911/E911 for <<customer\_short\_name>> customers in the same manner that it is provided to BellSouth customers. BellSouth shall provide and validate <<customer\_short\_name>> customer information to the PSAP. BellSouth shall use its service order process to update and maintain, on the same schedule that it uses for its customers, the <<customer\_short\_name>> customer service information in the ALI/DMS (Automatic Location Identification/Location Information) databases used to support 911/E911 services.
- 3.17 BellSouth shall bill, and <<customer\_short\_name>> shall pay, the End User line charge associated with implementing Number Portability as set forth in BellSouth's FCC No. 1 tariff. This charge is not subject to the wholesale discount.
- 3.18 Pursuant to 47 CFR Section 51.617, BellSouth shall bill to <<customer\_short\_name>>, and <<customer\_short\_name>> shall pay, the End

User common line charges identical to the End User common line charges  
BellSouth bills its End Users.

3.19

[Parties Disagree]

[<<customer\_short\_name>> Version] New Resale Services/Changes in the Provisioning of Resale Services. BellSouth **shall** provide to <<customer\_short\_name>> **electronically forty-five (45) days advance of changes to the prices, terms or conditions of services available for Resale, including but not limited to the introduction or discontinuance of any features, functions, services or promotions. To the extent that revisions occur between the time BellSouth notifies<<customer\_short\_name>> of changes under this Agreement and the time the changes are scheduled to be implemented, BellSouth will notify <<customer\_short\_name>> of such revisions consistent with its internal notification process; provided that, <<customer\_short\_name>> shall not utilize any notice given under this subsection to market resold offerings of that service in advance of BellSouth. Notwithstanding the foregoing, <<customer\_short\_name>> shall not utilize any such BellSouth service descriptions as part of its own sales or marketing efforts.**

[BellSouth Version] New Resale Services/Changes in Provision of Resale Services. BellSouth **may** provide <<customer\_short\_name>> **notice via Internet posting of price changes and changes to the terms and conditions of services available for resale. BellSouth shall provide notice of discontinuance of resold services and notice of rate increases on resold services ten (10) calendar days prior to its End Users pursuant to Commission rule or order. BellSouth will post on its website changes to business processes and policies, notices of new service offerings, and changes to service offerings not requiring an amendment to this Agreement, notices required to be posted, and any other information of general applicability to CLECs.**

4. **BellSouth's Provision of Services to <<customer\_short\_name>> for Resale**

4.1 The resale of telecommunications services shall be limited to users and uses conforming to the class of service restrictions.

4.1.1 BellSouth may request relevant documentation related to services purchased by <<customer\_short\_name>> to verify <<customer\_short\_name>>'s claims for discounts and asserted volumes, if BellSouth has a reasonable basis upon which to suspect that such claims are invalid. Such request shall be made on a nondiscriminatory basis and shall not occur more than once in a twelve (12) month period. <<customer\_short\_name>> shall maintain sufficient records and data, for a period up to six (6) months, that are relevant and reasonably necessary to determine compliance with tariff provisions regarding such discounts and for verifying asserted volumes to BellSouth. BellSouth shall bear the costs associated with said request if such claims for discounts and volumes are valid. Any

information provided by <<customer\_short\_name>> for purposes of such request shall be deemed Confidential Information pursuant to the General Terms and Conditions of this Agreement.

- 4.2 Subject to Exhibit A hereto, resold services can only be used in the same manner as specified in BellSouth's Tariffs. Resold services are subject to the same terms and conditions as are specified for such services when furnished to an individual End User of BellSouth in the appropriate section of BellSouth's Tariffs. In accordance with FCC 47 C.F.R. Section 51.603, BellSouth will provide services to <<customer\_short\_name>> for resale that are equal in quality, subject to the same conditions, and provided within the same provisioning time intervals that BellSouth provides these services to others, including End Users. Usage allowances (e.g., Business Plus\* service) described in BellSouth's tariffs shall not be aggregated for more than one end user or across multiple resold services. Volume discount offerings (e.g., Watsaver® service) may be aggregated by <<customer\_short\_name>> for multiple end users.
- 4.3 <<customer\_short\_name>> may resell services only within the specific service area as defined in its certificate of operation approved by the Commission.
- 4.4 If <<customer\_short\_name>> cancels an order for resold services, any costs incurred by BellSouth in conjunction with provisioning of such order will be recovered in accordance with BellSouth's General Subscriber Services Tariffs and Private Line Services Tariffs.
- 4.5 Service Jointly Provisioned with an Independent Company or Competitive Local Exchange Company Areas
- 4.5.1 BellSouth will in some instances provision resold services in accordance with the General Subscriber Services Tariff and Private Line Tariffs jointly with an Independent Company or other Competitive Local Exchange Carrier.
- 4.5.2 When <<customer\_short\_name>> assumes responsibility for such service, all terms and conditions defined in the Tariff will apply for services provided within the BellSouth service area only.
- 4.5.3 Service terminating in an Independent Company or other Competitive Local Exchange Carrier area will be provisioned and billed by the Independent Company or other Competitive Local Exchange Carrier directly to <<customer\_short\_name>>.
- 4.5.4 <<customer\_short\_name>> must establish a billing arrangement with the Independent Company or other Competitive Local Exchange Carrier prior to assuming an end user account where such circumstances apply.
- 4.6 Requirements for Specific Services. BellSouth shall make available for resale the services included in this Section 4.6 at the discounts set forth in Exhibit E to this Attachment and in accordance with Exhibit A to this Attachment.

- 4.6.1 Lifeline and Link-up. BellSouth shall make available Lifeline and Link-up Services for resale in accordance with Commission and FCC rules and regulations and with the reasonable and nondiscriminatory terms and conditions set forth in BellSouth's applicable tariffs. Such services shall be available to <<customer\_short\_name>> for resale only to those <<customer\_short\_name>> subscribers who meet the qualifications as set forth in applicable regulations. BellSouth shall indicate with a USOC on the customer service record if a customer is subscribing to Lifeline or Link-up. <<customer\_short\_name>> shall comply with all aspects of the FCC's and the Commission's orders and rules implementing Lifeline and Link-up programs. To the extent other Voluntary Federal Subscriber Financial Assistance Programs are offered by BellSouth and to the extent BellSouth is required to make such programs available for resale, such programs shall be offered to <<customer\_short\_name>> on rates, terms and conditions as required by Applicable Law.
- 4.6.2 Grandfathered Services. BellSouth shall offer for resale to <<customer\_short\_name>>pursuant to FCC 47 C.F.R. 51.615 all grandfathered services.
- 4.6.3 N11 Service. BellSouth shall make available for resale any existing N11 services at the discount rates set forth in Exhibit E to this Attachment 1 and in accordance with Exhibit A to this Attachment 1.
- 4.6.4 911/E911 Service. <<customer\_short\_name>> shall have the right to resell 911 or E911 services.
- 4.6.5 Customer Specific Offerings Including Contract Service Arrangements (CSAs) and other contractual arrangements. CSAs shall be available for resale, at the same rates, terms and conditions offered to BellSouth's end users, and in accordance with Commission and FCC Rules and Regulations less the wholesale discount set forth in Exhibit E to this Attachment 1. In cases where <<customer\_short\_name>> resells an existing CSA, termination liability will not be triggered by a transfer of the CSA from BellSouth to <<customer\_short\_name>>. <<customer\_short\_name>> may resale an existing CSA to the existing End User or to another similarly situated End User. End Users are similarly situated if their quantity of use and time of use, and the manner and costs of service are the same.
- 4.6.6 Promotions. For purposes of this Agreement, a "short term" promotion will be as set forth in FCC 47 C.F.R. 51.613.
- 4.6.6.1 BellSouth shall make Telecommunications Services subject to short term promotions available to <<customer\_short\_name>> at the short term promotional rate consistent with Exhibit A.
- 4.6.6.2 The inclusion of a telecommunications service, available for resale at a resale discount, as a component of a promotion, shall not relieve BellSouth of the

obligation to offer such underlying telecommunications service separately for resale at the resale discount.

- 4.6.6.3 Promotions of greater than 90 days will be available to <<customer\_short\_name>> for resale.
- 4.6.7 Special Assemblies. Existing special assembly agreements for telecommunications services shall be available for resale, at the same terms and conditions offered to BellSouth's end users. A special assembly shall be made available for resale at the price of the special assembly less the wholesale discount. <<customer\_short\_name>> shall be responsible for all terms and conditions of such special assembly including but not limited to termination liability if applicable. Termination liability will not be triggered as a result of a transfer of the special assembly from BellSouth to <<customer\_short\_name>>.
- 4.6.8 Volume Discount Plans. Subject to Section 4.2 to the extent BellSouth offers, pursuant to its Tariffs, any services the rate for which varies depending upon the volume purchased or the term for which the subscribers commit to purchase such service, BellSouth shall offer such services on the same terms and conditions to <<customer\_short\_name>>.
- 4.6.9 Pay Phone Service. BellSouth shall make available to <<customer\_short\_name>> for resale Public Telephone Access Services (pay phone/PTAS) to the extent BellSouth is required to do so pursuant to FCC and Commission rules.
- 4.6.10 Voice Mail Service. Where available to BellSouth's end users, BellSouth shall provide the following Telecommunications Services at a discount, as set forth in Exhibit E of this Attachment 1, for use in conjunction with voice mail services:
- Message Waiting Indicator (MWI) stutter dial tone and message waiting light feature capabilities.
  - CF/Busy (Call Forward Busy Line).
  - CF/DA (Call Forward Don't Answer).

The services listed in BellSouth's Messaging Services Information Package shall be made available for resale, without the wholesale discount, in conjunction with other tariff services offered for resale.

- 4.6.11 BellSouth shall provide branding for, or shall unbrand, voice mail services for <<customer\_short\_name>> per the Bona Fide Request/New Business Request process as set forth in Attachment 11 of this Agreement.
- 4.6.12 Hotel and Hospital PBX services are the only telecommunications services available for resale to Hotel/Motel and Hospital End Users, respectively in accordance with Section A2 of BellSouth's GSST. Similarly, Access Line



Service for Customer Provided Coin Telephones is the only local service available for resale to Payphone Service Provider (PSP) customers in accordance with Section A7 of BellSouth's GSST. Shared Tenant Service customers can only be sold those local exchange access services available in Section A23 of BellSouth's GSST in the states of Florida, Georgia, North Carolina and South Carolina, and in Section A27 of BellSouth's GSST in the states of Alabama, Kentucky, Louisiana, Mississippi and Tennessee. Notwithstanding the foregoing, if BellSouth offers other services that BellSouth is obligated to make available for resale to CLECs at the wholesale discount to Hotel/Motel and Hospital End Users, PSPs and shared tenant services customers, such services shall be available to <<customer\_short\_name>> for resale to such customers.

- 4.6.13 Advanced Intelligent Network (AIN). BellSouth shall provide for resale all Advanced Intelligent Network (AIN) services currently provided pursuant to BellSouth's GSST.
- 4.6.14 Miscellaneous Service Arrangements. <<customer\_short\_name>> may purchase at the wholesale discount set forth in Exhibit E to this Attachment 1, the entire set of Miscellaneous Service Arrangements (contained in Section A13 of the GSST with the exception of Information Services), or a subset of any one or any combination of such features on an end user-specific basis, without restriction on the minimum or maximum number of lines and features that may be purchased for any one level of service to the extent such restrictions do not apply to BellSouth's retail end users.
- 4.6.15 Blocking Service. BellSouth shall provide call blocking of 700, 900, and 976 services upon request as well as bill to third party and collect calls from <<customer\_short\_name>> on a line or trunk basis at parity pursuant to Section A13.9 of BellSouth's General Subscriber Services Tariff.
- 4.6.16 Busy Line Verification (BLV) and Emergency Line Interrupt (ELI). Where BellSouth does not route operator services traffic to <<customer\_short\_name>>'s platform, BellSouth shall perform BLV/ELI for <<customer\_short\_name>> on resold BellSouth lines.
- 4.6.17 Inside Wire Maintenance Plan. BellSouth's Inside Wire Maintenance Service Plan is available for resale in accordance with Exhibit A to this Attachment 1 and with Commission and FCC rules and regulations.
- 4.6.18 MemoryCall Service. BellSouth's MemoryCall Service is available for resale in accordance with Exhibit A to this Attachment 1 and with Commission and FCC rules and regulations.
- 4.6.19 Mobile Services. BellSouth's Mobile Services is available for resale in accordance with Exhibit A to this Attachment 1 and with Commission and FCC rules and regulations.

- 4.6.20 Federal Subscriber Line Charges. BellSouth's Federal Subscriber Line Charges will be passed on to <<customer\_short\_name>>.
- 4.6.21 Non-Recurring Charges. Non-Recurring Charges associated with services available for resale, where applicable, will be assessed at the discount rates set forth in Exhibit E to this Attachment 1 and in accordance with Exhibit A to this Attachment and with Commission and FCC rules and regulations.
- 4.6.22 End User Line Change/Number Portability Charge. BellSouth's End User Line Change/Federal Number Portability Charge will be passed on to <<customer\_short\_name>>.
- 4.6.23 AdWatch Service. BellSouth's AdWatch Service is available for resale at the discount rates set forth in Exhibit E to this Attachment 1 and in accordance with Exhibit A to this Attachment and with Commission and FCC rules and regulations.

## **5. Maintenance of Services**

- 5.1 Services resold pursuant to this Attachment and BellSouth's General Subscriber Service Tariff and Private Line Service Tariff and facilities and equipment provided by BellSouth shall be maintained by BellSouth.
- 5.2 <<customer\_short\_name>> or its End Users may not rearrange, move, disconnect, remove or attempt to repair any facilities owned by BellSouth except with the written consent of BellSouth.
- 5.3 To the extent known by appropriate personnel, <<customer\_short\_name>> will use best efforts to notify BellSouth of situations that arise that may result in a service problem. BellSouth will advise <<customer\_short\_name>> of any central office, facility, or network failure that is known at the time of any inquiry or trouble report by <<customer\_short\_name>>.
- 5.4 <<customer\_short\_name>> will contact the appropriate repair centers in accordance with procedures established in the BellSouth Operational Understanding Guide located at [http://www.interconnection.bellsouth.com/guides/html/other\\_guides/html](http://www.interconnection.bellsouth.com/guides/html/other_guides/html).
- 5.5 For all repair requests, <<customer\_short\_name>> shall adhere to BellSouth's prescreening guidelines prior to referring the trouble to BellSouth as set forth in the BellSouth Operational Understanding Guide located at [http://www.interconnection.bellsouth.com/guides/html/other\\_guides/html](http://www.interconnection.bellsouth.com/guides/html/other_guides/html).
- 5.6 BellSouth will bill <<customer\_short\_name>> for handling troubles that are found not to be in BellSouth's network pursuant to its standard time and material charges. The standard time and material charges will be no more than what

BellSouth charges to its retail customers for handling troubles that are not found to be in BellSouth's network.

- 5.7 BellSouth reserves the right to contact <<customer\_short\_name>>'s End Users, if deemed necessary, for maintenance purposes.

## **6. Establishment of Account**

- 6.1 Establishment of an account for resale will be done according to the terms of Section 1.2 of Attachment 7 to this Agreement.

## **7. Establishment of Service**

- 7.1 BellSouth will accept a request directly from the End User for conversion of the End User's service from <<customer\_short\_name>> to BellSouth or will accept a request from another CLEC for conversion of the End User's service from <<customer\_short\_name>> to such other CLEC. Upon completion of the conversion BellSouth will notify <<customer\_short\_name>> that such conversion has been completed.

## **8. Discontinuance of Service to End Users**

- 8.1 The procedures for discontinuing service to an End User are as follows:
- 8.1.1 BellSouth will deny service to <<customer\_short\_name>>'s End User on behalf of, and at the request of, <<customer\_short\_name>>. Upon restoration of the End Users's service, restoral charges will apply and will be the responsibility of <<customer\_short\_name>>.
- 8.1.2 At the request of <<customer\_short\_name>>, BellSouth will disconnect a <<customer\_short\_name>> End User customer.
- 8.1.3 All requests by <<customer\_short\_name>> for denial or disconnection of an End User for nonpayment must be in writing.
- 8.1.4 <<customer\_short\_name>> will be made solely responsible for notifying the End User of the proposed disconnection of the service.

## **9. Discontinuance of Service to <<cusomer\_short\_name>>**

- 9.1 Discontinuance of service to <<customer\_short\_name>> will be done according to the terms of Section 1.6 of Attachment 7 to this Agreement.

## **10. Operator Services (Operator Call Processing and Directory Assistance)**

- 10.1 Operator Call Processing. Operator\_Call Processing provides: (1) operator handling for call completion (for example, collect, third number billing, and manual calling-card calls). (2) operator or automated assistance for billing after

the end user has dialed the called number (for example, calling card calls); and (3) special services including but not limited to Busy Line Verification and Emergency Line Interrupt (ELI), Emergency Agency Call and Operator-assisted Directory Assistance.

- 10.2 Upon request for BellSouth Operator Call Processing, BellSouth shall:
  - 10.2.1 Process 0+ and 0- dialed local calls
  - 10.2.2 Process 0+ and 0- intraLATA toll calls.
  - 10.2.3 Process calls that are billed to <<customer\_short\_name>> end user's calling card that can be validated by BellSouth.
  - 10.2.4 Process person-to-person calls.
  - 10.2.5 Process collect calls.
  - 10.2.6 Provide the capability for callers to bill a third party and shall also process such calls.
  - 10.2.7 Process station-to-station calls.
  - 10.2.8 Process Busy Line Verify and Emergency Line Interrupt requests.
  - 10.2.9 Process emergency call trace originated by Public Safety Answering Points.
  - 10.2.10 Process operator-assisted directory assistance calls.
  - 10.2.11 Adhere to equal access requirements, providing <<customer\_short\_name>> local end users the same IXC access that BellSouth provides its own operator service.
  - 10.2.12 Exercise at least the same level of fraud control in providing Operator Service to <<customer\_short\_name>> that BellSouth provides for its own operator service.
  - 10.2.13 Perform Billed Number Screening when handling Collect, Person-to-Person, and Billed-To-Third-Party calls.
  - 10.2.14 Direct customer account and other similar inquiries to the customer service center designated by <<customer\_short\_name>>.
  - 10.2.15 Provide call records to <<customer\_short\_name>> in accordance with ODUF standards.
  - 10.2.16 The interface requirements shall conform to the interface specifications for the platform used to provide Operator Services as long as the interface conforms to industry standards.

10.3 Directory Assistance Service

10.3.1 Directory Assistance Service provides local and non-local end user telephone number listings with the option to complete the call at the caller's direction separate and distinct from local switching.

10.3.2 Directory Assistance Service shall provide up to two listing requests per call, if available and if requested by <<customer\_short\_name>>'s end user. BellSouth shall provide caller-optional directory assistance call completion service at rates set forth in BellSouth's General Subscriber Services Tariff to one of the provided listings.

10.4 Directory Assistance Service Updates

10.4.1 BellSouth shall update end user listings changes daily. These changes include:

10.4.2 New end user connections

10.4.3 End user disconnections

10.4.4 End user address changes

10.4.5 These updates shall also be provided for non-listed and non-published numbers for use in emergencies.

10.5 Branding for Operator Call Processing and Directory Assistance

10.5.1 BellSouth's branding feature provides a definable announcement to <<customer\_short\_name>> end users using Directory Assistance (DA)/ Operator Call Processing (OCP) prior to placing such end users in queue or connecting them to an available operator or automated operator system. This feature allows <<customer\_short\_name>>'s name on whose behalf BellSouth is providing Directory Assistance and/or Operator Call Processing. Rates for the branding features are set forth in Exhibit E of this Attachment.

11.5.2 BellSouth offers three branding offering options to <<customer\_short\_name>> when ordering BellSouth's Directory Assistance and Operator Call Processing: BellSouth Branding, Unbranding and Custom Branding.

11.5.3 Upon receipt of the branding order from <<customer\_short\_name>>, the order is considered firm after ten (10) business days. Should <<customer\_short\_name>> decide to cancel the order, written notification to <<customer\_short\_name>>'s BellSouth Account Executive is required. If <<customer\_short\_name>> decides to cancel after ten (10) business days from receipt of the branding order, <<customer\_short\_name>> shall pay all charges per the order.

11.6 Selective Call Routing using Line Class Codes (SCR-LCC)

- 11.6.1 Where <<customer\_short\_name>> resells BellSouth's services and utilizes an operator services provider other than BellSouth, BellSouth will route <<customer\_short\_name>>'s end user calls to that provider through Selective Call Routing.
- 11.6.2 Selective Call Routing using Line Class Codes (SCR-LCC) provides the capability for <<customer\_short\_name>> to have its OCP/DA calls routed to BellSouth's OCP/DA platform for BellSouth provided Custom Branded or Unbranded OCP/DA or to its own or an alternate OCP/DA platform for Self-Branded OCP/DA. SCR-LCC is only available if line class code capacity is available in the requested BellSouth end office switches.
- 11.6.3 Custom Branding for Directory Assistance is not available for certain classes of service, including but not limited to Hotel/Motel services, WATS service and certain PBX services.
- 11.6.4 Where available, <<customer\_short\_name>> specific and unique line class codes are programmed in each BellSouth end office switch where <<customer\_short\_name>> intends to service end users with customized OCP/DA branding. The line class codes specifically identify <<customer\_short\_name>>'s end users so OCP/DA calls can be routed over the appropriate trunk group to the request OCP/DA platform. Additional line class codes are required in each end office if the end office serves multiple NPAs (i.e., a unique LCC is required per NPA), and/or if the end office switch serves multiple rate areas and <<customer\_short\_name>> intends to provide <<customer\_short\_name>> branded OCP/DA to its end users in these multiple rate areas.
- 11.6.5 BellSouth Branding is the default branding offering.
- 11.6.6 [Parties Disagree]
- [<<customer\_short\_name>> Version] SCR-LCC supporting Custom Branding and Self Branding require <<customer\_short\_name>> to order dedicated transport and trunking from each BellSouth end office identified by <<customer\_short\_name>>, either to the BellSouth Traffic Operator Position System (TOPS) for Custom Branding or to the <<customer\_short\_name>> Operator Service Provider for Self Branding. Separate trunk groups are required for Operator Services and for Directory Assistance. Rates, terms and conditions for transport and trunks are set forth in **Attachment 2 to this Agreement**.
- [BellSouth Version] SCR-LCC supporting Custom Branding and Self Branding require <<customer\_short\_name>> to order dedicated transport and trunking from each BellSouth end office identified by <<customer\_short\_name>>, either to the BellSouth Traffic Operator Position System (TOPS) for Custom Branding or to the <<customer\_short\_name>> Operator Service Provider for Self Branding. Separate trunk groups are required for Operator Services and for Directory

Assistance. Rates, terms and conditions for transport and trunks are set forth in **the applicable BellSouth Tariffs**.

- 11.6.7 The rates for SCR-LCC are as set forth in Exhibit E of this Attachment. There is a nonrecurring charge for the establishment of each Line Class Code in each BellSouth central office.
- 11.6.8 Unbranded Directory Assistance and/or Operator Call Processing calls ride common trunk groups provisioned by BellSouth from those end offices identified by <<customer\_short\_name>> to the BellSouth Tops. The calls are routed to "No Announcement."
- 11.7 Branding via Originating Line Number Screening (OLNS)
- 11.7.1 BellSouth Branding, Unbranding and Custom Branding are also available for Directory Assistance, Operator Call Processing or both via OLNS software. When utilizing this method of Unbranding or Custom Branding <<customer\_short\_name>> shall not be required to purchase direct trunking.
- 11.7.2 BellSouth Branding is the default branding offering.
- 11.7.3 For BellSouth to provide Unbranding or Custom Branding via OLNS software for Operator Call Processing or for Directory Assistance <<customer\_short\_name>> must have its Operating Company Number (OCN(s)) and telephone numbers reside in BellSouth's LIDB; however, a BellSouth LIDB Storage Agreement is not required. To Implement Unbranding and Custom Branding via OLNS software, <<customer\_short\_name>> must submit a manual order form which requires, among other things, <<customer\_short\_name>>'s OCN and a forecast for the traffic volume anticipated for each BellSouth TOPS during the peak busy hour. <<customer\_short\_name>> shall provide updates to such forecast on a quarterly basis and at any time such forecasted traffic volumes are expected to change significantly. Upon <<customer\_short\_name>>'s purchase of Unbranding and Custom Branding using OLNS software for any particular TOPS, all <<customer\_short\_name>> end users served by that TOPS will receive the Unbranded "no announcement" or the Custom Branded announcement.
- 11.7.4 Rates for Unbranding and Custom Branding via OLNS software for Directory Assistance and for Operator Call Processing are as set forth in Exhibit E of this Attachment. Notwithstanding anything to the contrary in this Agreement, to the extent BellSouth is unable to bill <<customer\_short\_name>> applicable charges currently, BellSouth shall track such charges and will bill the same retroactively at such time as a billing process is implemented. In addition to the charges for Unbranding and Custom Branding via OLNS software, <<customer\_short\_name>> shall continue to pay BellSouth applicable labor and other charges for the use of BellSouth's Directory Assistance and Call Processing platforms as set forth in Exhibit E of this Attachment.

- 11.7.5 Customized Branding includes charges for the recording of the branding announcement and the loading of the audio units in each TOPS Switch and Network Applications Vehicle (NAV) equipment for which <<customer\_short\_name>> requires service.
- 11.7.6 Directory Assistance customized branding uses:
- 11.7.6.1 the recording of <<customer\_short\_name>>
- 11.7.6.2 the loading of the recording in each switch.
- 11.7.7 Operator Call Processing customized branding uses:
- 11.7.7.1 the recording of <<customer\_short\_name>>
- 11.7.7.2 the loading of the recording in each switch.
- 11.7.7.3 the loading on the Network Applications Vehicle (NAV). All NAV shelves within the region where the customer is offering service must be loaded.

## **12. Line Information Database (LIDB)**

- 12.1 BellSouth will store in its Line Information Database (LIDB) records relating to service only in the BellSouth region. The LIDB Storage Agreement is included in this Attachment as Exhibit B.
- 12.2 BellSouth will provide LIDB Storage upon written request to <<customer\_short\_name>>'s Account Manager stating a requested activation date.

## **13. RAO Hosting**

- 13.1 RAO Hosting is not required for resale in the BellSouth region.

## **14. Optional Daily Usage File (ODUF)**

- 14.1 The Optional Daily Usage File (ODUF) Agreement with terms and conditions is included in this Attachment as Exhibit C. Rates for ODUF are as set forth in Exhibit E of this Attachment.
- 14.2 BellSouth will provide ODUF service upon written request to its Account Manager stating a requested activation date.

## **14. Enhanced Optional Daily Usage File (EODUF)**

- 14.1 The Enhanced Optional Daily Usage File (EODUF) service Agreement with terms and conditions is included in this Attachment as Exhibit D. Rates for EODUF are as set forth in Exhibit E of this Attachment.



14.2

BellSouth will provide EODUF service upon written request to its Account Manager stating a requested activation date.

**EXCLUSIONS AND LIMITATIONS ON SERVICES AVAILABLE FOR RESALE (Note 3)**

Type of Service	AL		FL		GA		KY		LA		MS		NC		SC		TN	
	Resale	Discount	Resale	Discount	Resale	Discount	Resale	Discount	Resale	Discount	Resale	Discount	Resale	Discount	Resale	Discount	Resale	Discount
1 Grandfathered Services (Note 1)	Yes	Yes	Yes	Yes	Yes	Yes	Yes	Yes	Yes	Yes	Yes	Yes	Yes	Yes	Yes	Yes	Yes	Yes
2 Promotions - > 90 Days (Note 2)	Yes	Yes	Yes	Yes	Yes	Yes	Yes	Yes	Yes	Yes	Yes	Yes	Yes	Yes	Yes	Yes	Yes	Yes
3 Promotions - ≤ 90 Days (Note 2)	Yes	No	Yes	No	Yes	No	Yes	No	Yes	No	Yes	No	Yes	No	Yes	No	Yes	No
4 Lifeline/Link Up Services	Yes	Yes	Yes	Yes	Yes	Yes	No	No	Yes	Yes	Yes	Yes	Yes	Yes	Yes	Yes	Yes	Yes
5 911/E911 Services	Yes	Yes	Yes	Yes	Yes	Yes	Yes	Yes	No	No	Yes	Yes	Yes	Yes	Yes	Yes	Yes	Yes
6 N11 Services	Yes	Yes	Yes	Yes	Yes	Yes	No	No	No	No	Yes	Yes	Yes	Yes	No	No	Yes	Yes
7 MemoryCall® Service	Yes	No	Yes	No	Yes	No	Yes	No	Yes	No	Yes	No	Yes	No	Yes	No	Yes	No
8 Mobile Services	Yes	No	Yes	No	Yes	No	Yes	No	Yes	No	Yes	No	Yes	No	Yes	No	Yes	No
9 Federal Subscriber Line Charges	Yes	No	Yes	No	Yes	No	Yes	No	Yes	No	Yes	No	Yes	No	Yes	No	Yes	No
10 Non-RecurCharges	Yes	Yes	Yes	Yes	Yes	Yes	Yes	Yes	Yes	Yes	Yes	Yes	Yes	Yes	Yes	Yes	Yes	No
11 End User Line Chg-Number Portability	Yes	No	Yes	No	Yes	No	Yes	No	Yes	No	Yes	No	Yes	No	Yes	No	Yes	No
12 Public Telephone Access Svc(PTAS)	Yes	Yes	Yes	Yes	Yes	Yes	Yes	Yes	Yes	Yes	Yes	Yes	Yes	Yes	Yes	No	Yes	Yes
13 Inside Wire Maint Service Plan	Yes	No	Yes	No	Yes	No	Yes	No	Yes	No	Yes	No	Yes	No	Yes	No	Yes	No
<b>Applicable Notes:</b>																		
1.	<b>Grandfathered services</b> can be resold only to existing subscribers of the grandfathered service.																	
2.	Where available for resale, <b>promotions</b> will be made available only to End Users who would have qualified for the promotion had it been provided by BellSouth directly.																	
3.	Some of BellSouth's local exchange and toll telecommunications services are not available in certain central offices and areas.																	

## LINE INFORMATION DATA BASE (LIDB)

### RESALE STORAGE AGREEMENT

#### I. Definitions (from Addendum)

- A. Billing number - a number used by BellSouth for the purpose of identifying an account liable for charges. This number may be a line or a special billing number.
- B. Line number - a ten-digit number assigned by BellSouth that identifies a telephone line associated with a resold local exchange service.
- C. Special billing number - a ten-digit number that identifies a billing account established by BellSouth in connection with a resold local exchange service.
- D. Calling Card number - a billing number plus PIN number assigned by BellSouth.
- E. PIN number - a four-digit security code assigned by BellSouth that is added to a billing number to compose a fourteen-digit calling card number.
- F. Toll billing exception indicator - associated with a billing number to indicate that it is considered invalid for billing of collect calls or third number calls or both, by <<customer\_short\_name>>.
- G. Billed Number Screening - refers to the query service used to determine whether a toll billing exception indicator is present for a particular billing number.
- H. Calling Card Validation - refers to the query service used to determine whether a particular calling card number exists as stated or otherwise provided by a caller.
- I. Billing number information - information about billing number or Calling Card number as assigned by BellSouth and toll billing exception indicator provided to BellSouth by <<customer\_short\_name>>.
- J. Get-Data - refers to the query service used to determine, at a minimum, the Account Owner and/or Regional Accounting Office for a line number. This query service may be modified to provide additional information in the future.
- K. Originating Line Number Screening (OLNS) - refers to the query service used to determine the billing, screening and call handling indicators, station type and Account Owner provided to BellSouth by <<customer\_short\_name>> for originating line numbers.

- L. Account Owner - name of the local exchange telecommunications company that is providing dialtone on a subscriber line.

## II. General

- A. This Agreement sets forth the terms and conditions pursuant to which BellSouth agrees to store in its LIDB certain information at the request of <<customer\_short\_name>> and pursuant to which BellSouth, its LIDB customers and <<customer\_short\_name>> shall have access to such information. In addition, this Agreement sets forth the terms and conditions for <<customer\_short\_name>>'s provision of billing number information to BellSouth for inclusion in BellSouth's LIDB. <<customer\_short\_name>> understands that BellSouth provides access to information in its LIDB to various telecommunications service providers pursuant to applicable tariffs and agrees that information stored at the request of <<customer\_short\_name>>, pursuant to this Agreement, shall be available to those telecommunications service providers. The terms and conditions contained herein shall hereby be made a part of this Agreement upon notice to <<customer\_short\_name>>'s account team and/or Local Contract Manager activate this LIDB Storage Agreement. The General Terms and Conditions of the Agreement shall govern this LIDB Storage Agreement.
- B. BellSouth will provide responses to on-line, call-by-call queries to billing number information for the following purposes:
  - 1. Billed Number Screening

BellSouth is authorized to use the billing number information to determine whether <<customer\_short\_name>> has identified the billing number as one that should not be billed for collect or third number calls.
  - 2. Calling Card Validation

BellSouth is authorized to validate a 14-digit Calling Card number where the first 10 digits are a line number or special billing number assigned by BellSouth, and where the last four digits (PIN) are a security code assigned by BellSouth.
  - 3. OLNS

BellSouth is authorized to provide originating line screening information for billing services restrictions, station type, call handling indicators, presubscribed interLATA and local carrier and account owner on the lines of <<customer\_short\_name>> from which a call originates.
  - 4. GetData

BellSouth is authorized to provide, at a minimum, the account owner and/or Regional Accounting Office information on the lines of <<customer\_short\_name>> indicating the local service provider and where billing records are to be sent for settlement purposes. This query service may be modified to provide additional information in the future.

#### 5. Fraud Control

BellSouth will provide seven days per week, 24-hours per day, fraud monitoring on Calling Cards, bill-to-third and collect calls made to numbers in BellSouth's LIDB, provided that such information is included in the LIDB query. BellSouth will establish fraud alert thresholds and will notify <<customer\_short\_name>> of fraud alerts so that <<customer\_short\_name>> may take action it deems appropriate.

### III. Responsibilities of the Parties

A. BellSouth will administer all data stored in the LIDB, including the data provided by <<customer\_short\_name>> pursuant to this Agreement, in the same manner as BellSouth's data for BellSouth's End User customers. BellSouth shall not be responsible to <<customer\_short\_name>> for any lost revenue which may result from BellSouth's administration of the LIDB pursuant to its established practices and procedures as they exist and as they may be changed by BellSouth in its sole discretion from time to time.

#### B. Billing and Collection Customers

BellSouth currently has in effect numerous billing and collection agreements with various interexchange carriers and billing clearing houses and as such these billing and collection customers (B&C Customers) query BellSouth's LIDB to determine whether to accept various billing options from End Users. Until such time as BellSouth implements in its LIDB and its supporting systems the means to differentiate <<customer\_short\_name>>'s data from BellSouth's data, the following shall apply:

- (1) BellSouth will identify <<customer\_short\_name>> end user originated long distance charges and will return those charges to the interexchange carrier as not covered by the existing B&C agreement. <<customer\_short\_name>> is responsible for entering into the appropriate agreement with interexchange carriers for handling of long distance charges by their end users.
- (2) BellSouth shall have no obligation to become involved in any disputes between <<customer\_short\_name>> and B&C Customers. BellSouth will not issue adjustments for charges billed on behalf of any B&C Customer to <<customer\_short\_name>>. It shall be the responsibility of <<customer\_short\_name>> and the B&C Customers to negotiate and arrange for any appropriate adjustments.

**IV. Fees for Service and Taxes**

- A. <<customer\_short\_name>> will not be charged a fee for storage services provided by BellSouth to <<customer\_short\_name>>, as described in this LIDB Resale Storage Agreement.
- B. Sales, use and all other taxes (excluding taxes on BellSouth's income) determined by BellSouth or any taxing authority to be due to any federal, state or local taxing jurisdiction with respect to the provision of the service set forth herein will be paid by <<customer\_short\_name>> in accordance with the tax provisions set forth in the General Terms and Conditions of this Agreement.

**Optional Daily Usage File**

1. Upon written request from <<customer\_short\_name>>, BellSouth will provide the Optional Daily Usage File (ODUF) service to <<customer\_short\_name>> pursuant to the terms and conditions set forth in this section. ODUF data delivery accuracy, completeness, timeliness and mean time to deliver will be in accordance with SQMs B3, B4, B5 and B6.
2. <<customer\_short\_name>> shall furnish all relevant information required by BellSouth for the provision of the ODUF.
3. The ODUF feed will contain messages that were carried over the BellSouth Network and processed in the BellSouth Billing System, but billed to a <<customer\_short\_name>> customer.
4. Charges for ODUF will appear on <<customer\_short\_name>>'s monthly bills for the previous month's usage. The charges are as set forth in Exhibit E to this Attachment. <<customer\_short\_name>> will be billed at the ODUF rates that are in effect at the end of the previous month.
5. The ODUF feed will contain both rated and unrated messages. All messages will be in the standard Alliance for Telecommunications Industry Solutions (ATIS) EMI record format.
6. Messages that error in the billing system of <<customer\_short\_name>> will be the responsibility of <<customer\_short\_name>>. If, however, <<customer\_short\_name>> should encounter significant volumes of errored messages that prevent processing by <<customer\_short\_name>> within its systems, BellSouth will work with <<customer\_short\_name>> to determine the source of the errors and the appropriate resolution. Upon request from <<customer\_short\_name>>, BellSouth shall resend errored messages in accordance with SQM B-9.
6. The following specifications shall apply to the ODUF feed.
  - 6.1 ODUF Message to be Transmitted
    - 6.1.1 The following messages recorded by BellSouth will be transmitted to <<customer\_short\_name>>:
      - Message recording for per use/per activation type services (examples: Three Way Calling, Verify, Interrupt, Call Return, etc.)
      - Measured Local

- Directory Assistance messages
  - IntraLATA Toll
  - WATS and 800 Service
  - N11
  - Information Service Provider Messages
  - Operator Services Messages
  - Operator Services Message Attempted Calls (Network Element only)
  - Credit/Cancel Records
  - Usage for Voice Mail Message Service
- 6.1.2 Rated Incollects (messages BellSouth receives from other revenue accounting companies) can also be on ODUF. Rated Incollects will be intermingled with BellSouth recorded rated and unrated usage. Rated Incollects will not be packed separately.
- 6.1.3 BellSouth will perform duplicate record checks on records processed to ODUF. Any duplicate messages detected will be deleted and not sent to <<customer\_short\_name>>.
- 6.1.4 In the event that <<customer\_short\_name>> detects a duplicate on ODUF they receive from BellSouth, <<customer\_short\_name>> will drop the duplicate message and will not return the duplicate to BellSouth).
- 6.2 ODUF Physical File Characteristics
- 6.2.1 ODUF will be distributed to <<customer\_short\_name>> via CONNECT:Direct, Connect: Enterprise Client or another mutually agreed medium. The ODUF feed will be a variable block format. The data on the ODUF feed will be in a non-compacted EMI format (175 byte format plus modules). It will be created on a daily basis Monday through Friday except holidays. Details such as dataset name and delivery schedule will be addressed during negotiations of the distribution medium. There will be a maximum of one dataset per workday per OCN.
- 6.2.2 Data circuits (private line or dial-up) will be required between BellSouth and <<customer\_short\_name>> for the purpose of data transmission when utilizing CONNECT:Direct. Where a dedicated line is required, <<customer\_short\_name>> will be responsible for ordering the circuit, and coordinating the installation with BellSouth. <<customer\_short\_name>> will also be responsible for any charges associated with this line. CSU/DSU equipment required on the BellSouth end to



attach the line to the mainframe computer and to transmit data will be the responsibility of <<customer\_short\_name>>. Where a dial-up facility is required, dial circuits will be installed in the BellSouth data center by BellSouth and the associated charges assessed to <<customer\_short\_name>>. Additionally, all message toll charges associated with the use of the dial circuit by <<customer\_short\_name>> will be the responsibility of <<customer\_short\_name>>. Associated equipment on the BellSouth end, including a modem, will be the responsibility of BellSouth. All equipment, including modems and software, that is required on <<customer\_short\_name>> end for the purpose of data transmission will be the responsibility of <<customer\_short\_name>>.

6.2.3 If <<customer\_short\_name>> utilizes CONNECT:Enterprise Client for data file transmission, purchase of the CONNECT:Enterprise Client software will be the responsibility of <<customer\_short\_name>>.

### 6.3 ODUF Packing Specifications

6.3.1 A pack will contain a minimum of one (1) message record or a maximum of ninety-nine thousand nine hundred and ninety-nine (99,999) message records plus a pack header record and a pack trailer record. One transmission can contain a maximum of ninety-nine (99) packs and a minimum of one (1) pack.

6.3.2 The OCN, From RAO, and Invoice Number will control the invoice sequencing. The From RAO will be used to identify to <<customer\_short\_name>> which BellSouth RAO that is sending the message. BellSouth and <<customer\_short\_name>> will use the invoice sequencing to control data exchange. BellSouth will be notified of sequence failures identified by <<customer\_short\_name>> and resend the data as quickly as technically possible.

The data will be packed using ATIS EMI records.

### 6.4 ODUF Pack Rejection

6.4.1 <<customer\_short\_name>> will notify BellSouth within one (1) business day of rejected packs (via the mutually agreed medium). Packs could be rejected because of pack sequencing discrepancies or a critical edit failure on the Pack Header or Pack Trailer records (i.e. out-of-balance condition on grand totals, invalid data populated). Standard ATIS EMI Error Codes will be used. <<customer\_short\_name>> will not be required to return the actual rejected data to BellSouth. Rejected packs will be corrected and retransmitted to <<customer\_short\_name>> by BellSouth.

### 6.5 ODUF Control Data

<<customer\_short\_name>> will send one (1) confirmation record per pack that is received from BellSouth. This confirmation record will indicate <<customer\_short\_name>>'s receipt of the pack and acceptance or rejection of the

pack. Pack Status Code(s) will be populated using standard ATIS EMI error codes for packs that were rejected by <<customer\_short\_name>> for reasons stated in the above section.

## 6.6 ODUF Testing

- 6.6.1 Upon request from <<customer\_short\_name>>, BellSouth shall send ODUF test files to <<customer\_short\_name>>. The Parties agree to review and discuss the ODUF content and/or format. For testing of usage results, BellSouth shall request that <<customer\_short\_name>> set up a production (live) file. The live test may consist of <<customer\_short\_name>>'s employees making test calls for the types of services <<customer\_short\_name>> requests on ODUF. These test calls are logged by <<customer\_short\_name>>, and the logs are provided to BellSouth. These logs will be used to verify the files. Testing will be completed within thirty (30) calendar days from the date on which the initial test file was sent.

## Enhanced Optional Daily Usage File

1. Upon written request from <<customer\_short\_name>>, BellSouth will provide the Enhanced Optional Daily Usage File (EODUF) service to <<customer\_short\_name>> pursuant to the terms and conditions set forth in this section. EODUF will only be sent to existing ODUF subscribers who request the EODUF option.
2. <<customer\_short\_name>> shall furnish all relevant information required by BellSouth for the provision of the EODUF.
3. The EODUF will provide usage data for local calls originating from resold Flat Rate Business and Residential Lines.
4. Charges for delivery of the EODUF will appear on <<customer\_short\_name>>'s monthly bills for the previous month's usage. The charges are as set forth in Exhibit E to this Attachment. <<customer\_short\_name>> will be billed at the EODUF rates that are in effect at the end of the previous month.
5. All messages will be in the standard Alliance for Telecommunications Industry Solutions (ATIS) EMI record format.
6. Messages that error in the billing system of <<customer\_short\_name>> will be the responsibility of <<customer\_short\_name>>. If, however, <<customer\_short\_name>> should encounter significant volumes of errored messages that prevent processing by <<customer\_short\_name>> within its systems, BellSouth will work with <<customer\_short\_name>> to determine the source of the errors and the appropriate resolution. Upon request from <<customer\_short\_name>>, BellSouth shall resend errored messages as required by SQM B-9.
7. The following specifications shall apply to the EODUF feed.
  - 7.1 Usage To Be Transmitted
    - 7.1.1 The following messages recorded by BellSouth will be transmitted to <<customer\_short\_name>>:

Customer usage data for flat rated local call originating from <<customer\_short\_name>>'s End User lines (1FB or 1FR). The EODUF record for flat rate messages will include:

Date of Call

From Number

To Number

Connect Time

Conversation Time

Method of Recording

From RAO

Rate Class

Message Type

Billing Indicators

Bill to Number

- 7.1.2 BellSouth will perform duplicate record checks on EODUF records processed to ODUF. Any duplicate messages detected will be deleted and not sent to <<customer\_short\_name>>.
- 7.1.3 In the event that <<customer\_short\_name>> detects a duplicate on EODUF they receive from BellSouth, <<customer\_short\_name>> will drop the duplicate message (<<customer\_short\_name>> will not return the duplicate to BellSouth).
- 7.2 Physical File Characteristics
- 7.2.1 The EODUF feed will be distributed to <<customer\_short\_name>> over their existing ODUF feed. The EODUF messages will be intermingled among <<customer\_short\_name>>'s ODUF messages. The EODUF will be a variable block format (2476) with a LRECL of 2472. The data on the EODUF will be in a non-compacted EMI format (175 byte format plus modules). It will be created on a daily basis (Monday through Friday except holidays).
- 7.2.2 Data circuits (private line or dial-up) may be required between BellSouth and <<customer\_short\_name>> for the purpose of data transmission as set forth in Section 6.2.2 above.
- 7.2.3 Data circuits (private line or dial-up) will be required between BellSouth and <<customer\_short\_name>> for the purpose of data transmission when utilizing CONNECT:Direct. Where a dedicated line is required, <<customer\_short\_name>> will be responsible for ordering the circuit, and coordinating the installation with BellSouth. <<customer\_short\_name>> will also be responsible for any charges associated with this line. CSU/DSU equipment required on the BellSouth end to attach the line to the mainframe computer and to transmit data will be the responsibility of <<customer\_short\_name>>. Where a dial-up facility is required, dial circuits will be installed in the BellSouth data center by BellSouth and the

associated charges assessed to <<customer\_short\_name>>. Additionally, all message toll charges associated with the use of the dial circuit by <<customer\_short\_name>> will be the responsibility of <<customer\_short\_name>>. Associated equipment on the BellSouth end, including a modem, will be the responsibility of BellSouth. All equipment, including modems and software, that is required on <<customer\_short\_name>> end for the purpose of data transmission will be the responsibility of <<customer\_short\_name>>.

### 7.3 Packing Specifications

7.3.1 A pack will contain a minimum of one (1) message record or a maximum of ninety-nine thousand nine hundred ninety-nine (99,999) message records plus a pack header record and a pack trailer record. One (1) transmission can contain a maximum of ninety-nine (99) packs and a minimum of one (1) pack.

7.3.2 The OCN, From (RAO), and Invoice Number will control the invoice sequencing. The From RAO will be used to identify to <<customer\_short\_name>> which BellSouth RAO is sending the message. BellSouth and <<customer\_short\_name>> will use the invoice sequencing to control data exchange. BellSouth will be notified of sequence failures identified by <<customer\_short\_name>> and resend the data as quickly as technically possible.

7.3.3 The data will be packed using ATIS EMI Records.

RESALE DISCOUNTS AND RATES - Kentucky															
CATEGORY	RATE ELEMENTS	Interim	Zone	BCS	USOC	RATES (\$)				Svc Order Submitted Elec per LSR	Svc Order Submitted Manually per LSR	Attachment: 1		Exhibit: E	
												Incremental Charge - Manual Svc Order vs. Electronic-1st	Incremental Charge - Manual Svc Order vs. Electronic-Add'l	Incremental Charge - Manual Svc Order vs. Electronic-Disc 1st	Incremental Charge - Manual Svc Order vs. Electronic-Disc Add'l
						Rec	Nonrecurring		Nonrecurring Disconnect			OSS Rates (\$)			
	First	Add'l	First	Add'l	SOMEc	SOMAN	SOMAN	SOMAN	SOMAN	SOMAN	SOMAN	SOMAN	SOMAN		
<b>APPLICABLE DISCOUNTS</b>															
	Residence %					16.79									
	Business %					15.54									
	CSAs %					15.54									
<b>OPERATIONAL SUPPORT SYSTEMS (OSS) - "REGIONAL RATES"</b>															
NOTE: (1) CLEC should contact its contract negotiator if it prefers the "state specific" OSS charges as ordered by the State Commissions. The OSS charges currently contained in this rate exhibit are the BellSouth "regional" service ordering charges. CLEC may elect either the state specific Commission ordered rates for the service ordering charges, or CLEC may elect the regional service ordering charge, however, CLEC can not obtain a mixture of the two regardless if CLEC has an interconnection contract established in each of the 9 states.															
	OSS - Electronic Service Order Charge, Per Local Service Request (LSR) - Resale Only				SOMEc	3.50	0.00	3.50	0.00						
	OSS - Manual Service Order Charge, Per Local Service Request (LSR) - Resale Only				SOMAN	19.99	0.00	19.99	0.00						
<b>SELECTIVE CALL ROUTING USING LINE CLASS CODES (SCR-LCC)</b>															
	Selective Routing Per Unique Line Class Code Per Request Per Switch					93.53	93.53	15.58	15.58						
<b>ODUF/EODUF SERVICES</b>															
<b>OPTIONAL DAILY USAGE FILE (ODUF)</b>															
	ODUF: Recording, per message					0.0000136									
	ODUF: Message Processing, per message					0.002506									
	ODUF: Message Processing, per Magnetic Tape provisioned					35.90									
	ODUF: Data Transmission (CONNECT:DIRECT), per message					0.00010372									
<b>ENHANCED OPTIONAL DAILY USAGE FILE (EODUF)</b>															
	EODUF: Message Processing, per message					0.235889									

## **Attachment 2**

### **Network Elements and Other Services**

## TABLE OF CONTENTS

1	GENERAL.....	3
2	UNBUNDLED LOOPS.....	9
3	LINE SHARING .....	38
4	LOCAL SWITCHING .....	46
5	UNBUNDLED NETWORK ELEMENT COMBINATIONS .....	55
6	TRANSPORT, CHANNELIZATION AND DARK FIBER .....	63
7	SERVICE CONTROL POINTS (SCPs) / DATABASES .....	68
8	TOLL FREE NUMBER DATABASE / BELLSOUTH SWITCHED ACCESS (SWA) 8XX TOLL FREE DIALING TEN DIGIT SCREENING SERVICE .....	69
9	LINE INFORMATION DATABASE .....	70
10	SIGNALING.....	73
11	AUTOMATIC LOCATION IDENTIFICATION / DATA MANAGEMENT SYSTEM (ALI/DMS) .....	80
12	CALLING NAME DATABASE SERVICE .....	80
13	SERVICE CREATION ENVIRONMENT AND SERVICE MANAGEMENT SYSTEM (SCE/SMS) ADVANCED INTELLIGENT NETWORK ACCESS (AIN TOOL).....	82
14	OPERATIONAL SUPPORT SYSTEMS (OSS) .....	82
	Rates .....	Exhibit A



## ACCESS TO NETWORK ELEMENTS AND OTHER SERVICES

### 1 General

#### 1.1 [Parties Disagree]

[<<customer\_short\_name>> Version] This Attachment sets forth rates, terms and conditions for Unbundled Network Elements (UNEs) and combinations of UNEs with other UNEs (Combinations) that BellSouth shall offer to <<customer\_short\_name>> in accordance with its obligations under Section 251(c)(3) of the Act. Additionally, this Attachment sets forth the rates, terms and conditions for other facilities and services BellSouth makes available to <<customer\_short\_name>> (Other Services). In providing access or obtaining access to UNEs, Combinations and Other Services, the Parties shall comply with all applicable FCC rules and orders and Commission rules and orders. **This Attachment is not intended to eliminate obligations set forth in FCC rules and orders and Commission rules and orders, however, to the extent obligations are addressed in the text of this Attachment and that text conflicts with obligations set forth in FCC rules and orders and Commission rules and orders, the text of this Attachment shall prevail. To the extent obligations set forth in FCC rules and orders and Commission rules and orders are not addressed in this Attachment, those obligations shall apply unless the text of this Attachment expressly states that a particular obligation does not apply.**

[BellSouth Version] This Attachment sets forth rates, terms and conditions for Unbundled Network Elements (UNEs) and combinations of UNEs with other UNEs (Combinations) that BellSouth shall offer to <<customer\_short\_name>> in accordance with its obligations under Section 251(c)(3) of the Act. Additionally, this Attachment sets forth the rates, terms and conditions for other facilities and services BellSouth makes available to <<customer\_short\_name>> (Other Services). In providing access or obtaining access to UNEs, Combinations and Other Services, the Parties shall comply with all applicable FCC rules and orders and Commission rules and orders. The rates for each UNE, Combination and Other Service are set forth in Exhibit A of this Attachment. **In the event of a conflict between this Attachment and any other Section or provision of this Agreement, the provisions of this Attachment shall control.**

1.1.1 Network Element is as defined in the FCC's rules.

1.1.2 Non-qualifying Service is as defined in the FCC's rules.

1.1.3 Qualifying Service is as defined in the FCC's rules.

1.1.4 Technically Feasible is as defined in the FCC's rules.

1.1.5 UNE is defined to mean the Network Elements that BellSouth is required to make available on an unbundled basis by the FCC or Commission pursuant to Section 251(c)(3) of the Act, FCC rules and orders and/or Commission rules and orders that are set forth in this Attachment.

1.2 [Parties Disagree]

[<<customer\_short\_name>> Version] **BellSouth shall provide UNEs and Other Services in accordance with all applicable FCC and Commission rules and orders, including but not limited to: *the Triennial Review Order*, 47 C.F.R 51.307, 51.309, 51.311, 51.313, 51.315, 51.316, 51.318, 51.319.**

<<customer\_short\_name>> may use UNEs in accordance with 47 C.F.R 51.309. References to FCC rules contained herein shall incorporate relevant text of the *Triennial Review Order*.

[BellSouth Version] <<customer\_short\_name>> may not access a UNE for the sole purpose of providing non-qualifying services, but may use an UNE to provide a non-qualifying service if it is using such UNE to provide a qualifying service.

1.3 BellSouth shall comply with the requirements set forth in the technical references identified in this Attachment. Such requirements shall be applied in a non-discriminatory manner and at parity and shall be in accord with all FCC and Commission requirements.

1.4 Conversions

1.4.1 Upon request, BellSouth shall convert a wholesale service, or group of wholesale services, to the equivalent UNE, or Combination in accordance with FCC 47 C.F.R. 51.316. Nonrecurring switch-as-is rates for conversion of wholesale services to UNEs are contained in Exhibit A of this Attachment. Conversion of a wholesale service or group of wholesale services to a UNE or Combination shall be considered termination for purposes of any volume and/or term commitments and/or grandfathered status-applicable to such wholesale services. Any change from a wholesale service to a UNE that requires a physical rearrangement of the UNE will not be considered a conversion for purposes of this Agreement. For arrangements that require a re-termination or other physical rearrangement of circuits to comply with the terms of this Agreement, nonrecurring charges for the UNE or Combination or cross connect from Exhibit A of this Attachment will apply. BellSouth will not require physical rearrangement if the conversion can be completed through record changes only.

1.4.2 [Parties Disagree]

[<<customer\_short\_name>> Version] **Without admission or prejudice as to any disputes the parties may have prior to the Effective Date of this Agreement, any price changes resulting from the conversion will be effective as**

of the next billing cycle following BellSouth's receipt of a complete and accurate conversion request from <<customer\_short\_name>>.

[BellSouth Version] Any price changes resulting from the conversion will be effective as of the next billing cycle following BellSouth's receipt of a complete and accurate conversion request from <<customer\_short\_name>>.

1.4.3

[Parties Disagree]

[<<customer\_short\_name>> Version] If <<customer\_short\_name>> wants to convert a UNE or Combination (or part thereof) to Other Services or tariffed BellSouth access services <<customer\_short\_name>> shall submit an **LSR or ASR, as appropriate, and the nonrecurring charges for such conversion shall be as set forth in Exhibit A of this Attachment or the relevant tariff, as appropriate. Such charges shall be commensurate with the work required to effectuate the conversion (cross connect only, billing change/records update only, etc.).**

[BellSouth Version] If <<customer\_short\_name>> wants to convert a UNE or Combination (or part thereof) to Other Services or tariffed BellSouth access services <<customer\_short\_name>> shall submit a **BFR or NBR.**

1.5

[Parties Disagree]

[<<customer\_short\_name>> Version] Except to the extent expressly provided otherwise in this Attachment, for UNEs or Combinations that are no longer offered pursuant to, or are not in compliance with, the terms set forth in this Agreement, <<customer\_short\_name>> will submit orders to rearrange or disconnect those arrangements or services within thirty (30) calendar days of **its receipt of notice from BellSouth identifying specific service arrangements that must be transitioned to other services pursuant to this Section.** If orders to rearrange or disconnect those arrangements or services are not received by the thirty-first (31<sup>st</sup>) calendar day after **receipt of such notice**, BellSouth may disconnect those arrangements or services without further notice, **provided that <<customer\_short\_name>> has not notified BellSouth of a dispute regarding the identification of specific service arrangements as being no longer offered pursuant to, or are not in compliance with, the terms set forth in this Agreement.** Where no re-termination or physical rearrangement of circuits or service is required, <<customer\_short\_name>> will be charged a nonrecurring switch-as-is charge for the individual Network Element(s) as set forth in Exhibit A of this Attachment. For arrangements that require a re-termination or other physical rearrangement of circuits to comply with the terms of this Agreement, nonrecurring charges for the applicable **UNE or cross connect** from Exhibit A of this Attachment will apply. To the extent re-termination or other physical rearrangement is required in order to comply with a tariff or separate agreement, the applicable rates, terms and conditions of such tariff or separate agreement shall apply.

[BellSouth Version] Except to the extent expressly provided otherwise in this Attachment, for UNEs or Combinations that are no longer offered pursuant to, or are not in compliance with, the terms set forth in this Agreement, <<customer\_short\_name>> will submit orders to rearrange or disconnect those arrangements or services within thirty (30) calendar days of **the Effective Date of this Agreement**. If orders to rearrange or disconnect those arrangements or services are not received by the thirty-first (31<sup>st</sup>) calendar day after **the Effective Date of this Agreement**, BellSouth may disconnect those arrangements or services without further notice. Where no re-termination or physical rearrangement of circuits or service is required, <<customer\_short\_name>> will be charged a nonrecurring switch-as-is charge for the individual UNE(s) as set forth in Exhibit A of this Attachment. For arrangements that require a re-termination or other physical rearrangement of circuits to comply with the terms of this Agreement, nonrecurring charges for the applicable UNE(s) from Exhibit A of this Attachment will apply. To the extent re-termination or other physical rearrangement is required in order to comply with a tariff or separate agreement, the applicable rates, terms and conditions of such tariff or separate agreement shall apply. **Applicable disconnect charges will apply to a UNE/Combination that is rearranged or disconnected.**

1.5.1

[Parties Disagree]

[<<customer\_short\_name>> Version] <<customer\_short\_name>> may utilize UNEs and Other Services to provide services in a manner consistent with applicable industry standards and applicable BellSouth Technical References incorporated into BellSouth's Guides found on BellSouth's website at <http://interconnection.bellsouth.com>. **This Section shall not be construed to limit <<customer\_short\_name>>'s ability to access and use UNEs, as set forth in Section 1.2 of this Attachment.**

[BellSouth Version] <<customer\_short\_name>> may utilize UNEs and Other Services to provide services in a manner consistent with applicable industry standards and applicable BellSouth Technical References incorporated into BellSouth's Guides found on BellSouth's website at <http://interconnection.bellsouth.com>.

1.6

Routine Network Modifications

1.6.1

[Parties Disagree]

[<<customer\_short\_name>> Version] BellSouth will perform Routine Network Modifications in accordance with FCC 47 C.F.R. 51.319 (a)(8) and (e)(5). If BellSouth has anticipated such Routine Network Modifications and performs them during normal operations, then BellSouth shall perform such Routine Network Modifications at no additional charge. Routine Network Modifications shall be performed within the intervals established for the UNE and subject to the performance measurements and associated remedies set forth in Attachment 9 to

the extent such Routine Network Modifications were anticipated in the setting of such intervals. If BellSouth has not anticipated a requested **or necessary** network modification as being a Routine Network Modification and, **as such**, has not recovered the costs of such Routine Network Modifications in the rates set forth in Exhibit A of this Attachment, then **BellSouth shall notify <<customer\_short\_name>> of the required Routine Network Modification and shall request that <<customer\_short\_name>> submit a service inquiry (SI) to have the work performed. Each unique request will be handled as a project on an individual case basis. BellSouth will provide a TELRIC-compliant price quote for the request, and upon receipt of a firm order from <<customer\_short\_name>>, BellSouth shall perform the Routine Network Modification.**

**[BellSouth Version]** BellSouth will perform Routine Network Modifications in accordance with FCC 47 C.F.R. 51.319 (a)(8) and (e)(5). **Except to the extent expressly provided otherwise in this Attachment**, if BellSouth has anticipated such Routine Network Modifications and performs them during normal operations **and has recovered the costs for performing such modifications through the rates set forth in Exhibit A of this Attachment**, then BellSouth shall perform such Routine Network Modifications at no additional charge. Routine Network Modifications shall be performed within the intervals established for the UNE and subject to the performance measurements and associated remedies set forth in Attachment 9 to the extent such Routine Network Modifications were anticipated in the setting of such intervals. If BellSouth has not anticipated a requested network modification as being a Routine Network Modification and has not recovered the costs of such Routine Network Modifications in the rates set forth in Exhibit A of this Attachment, then <<customer\_short\_name>> must submit a service inquiry (SI) to have the work performed. Each request will be handled as a project on an individual case basis. BellSouth will provide a price quote for the request, and upon receipt of **payment** from <<customer\_short\_name>>, BellSouth shall perform the Routine Network Modification.

1.7

**[Parties Disagree]**

**[<<customer\_short\_name Version]** Notwithstanding any other provision of this Agreement, BellSouth will not combine UNEs or Combinations with any service, Network Element or other offering that it is obligated to make available only pursuant to Section 271 of the Act.

**[BellSouth Version]** Notwithstanding any other provision of this Agreement, BellSouth will not **commingle or** combine UNEs or Combinations with any service, Network Element or other offering that it is obligated to make available only pursuant to Section 271 of the Act.

1.8

Commingling of Services

- 1.8.1 BellSouth shall provide commingling of services in accordance with FCC 47 C.F.R. 51.309.
- 1.8.2 BellSouth will not “ratchet” (i.e., billing a single circuit at multiple rates to develop a single, blended rate for) a commingled circuit. Unless otherwise agreed to by the Parties, the UNE portion of such circuit will be billed at the rates set forth in this Agreement and the remainder of the circuit or service will be billed in accordance with BellSouth’s tariffed or other contract rates.
- 1.8.3 [Parties Disagree]
- [<<customer\_short\_name>> Version] When multiplexing equipment is attached to a commingled circuit, the **multiplexing equipment** and Central Office Channel Interfaces will be billed from the same jurisdictional authorization (Agreement or tariff) as the lower bandwidth service.
- [BellSouth Version] When multiplexing equipment is attached to a commingled circuit, the **multiplexing equipment** will be billed from the same jurisdictional authorization (agreement or tariff) as the **higher bandwidth service**. The Central Office Channel Interface will be billed from the same jurisdictional authorization (tariff or agreement) as the lower **bandwidth** service.
- 1.8.4 If <<customer\_short\_name>> reports a trouble on a UNE or Other Service and no trouble actually exists on the BellSouth portion, BellSouth will charge <<customer\_short\_name>> at the rates set forth in Exhibit A to this Attachment for any dispatching and testing (both inside and outside the Central Office (CO)) required by BellSouth in order to confirm the working status. If <<customer\_short\_name>> reports the same trouble on the same UNE or Other Service within thirty (30) calendar days of BellSouth’s notification to <<customer\_short\_name>> of its disposition of the prior trouble, and BellSouth is able to determine that such trouble does exist on BellSouth’s network, <<customer\_short\_name>> shall be credited on the next billing cycle for charges associated with the prior trouble.
- 1.9 Rates
- 1.9.1 The prices that <<customer\_short\_name>> shall pay to BellSouth for UNEs, Combinations and Other Services are set forth in Exhibit A of this Attachment. To the extent a rate is required to be TELRIC-compliant, the rate in Exhibit A of this Attachment shall be TELRIC-compliant, and if Commission approved, is the Commission approved rates. If <<customer\_short\_name>> purchases a service(s) from a tariff, all terms and conditions and rates as set forth in such tariff shall apply. If no rate is identified in this Agreement for an UNE, Combination or Other Service that is required to be a TELRIC-compliant rate, the rate will be a TELRIC-compliant rate set by the Commission, or if no such rate has been set by a Commission, BellSouth shall propose an interim TELRIC-compliant rate based upon a cost study that BellSouth will provide upon request from

<<customer\_short\_name>>. If the rate is not required to be TELRIC-compliant, then the rate may be negotiated by the Parties upon request by either Party. If the Parties are unable to agree upon a rate, either Party may pursue dispute resolution.

1.9.2 Rates, terms and conditions for order cancellation charges and Service Date Advancement Charges will apply in accordance with Attachment 6. Service Date Advancement charges for expediting UNEs and Other Services orders and are as set forth in Exhibit A.

1.9.3 If <<customer\_short\_name>> modifies an order (Order Modification Charge (OMC)) after being sent a Firm Order Confirmation (FOC) from BellSouth, any costs incurred by BellSouth to accommodate the modification will be paid by <<customer\_short\_name>> in accordance with FCC No. 1 Tariff, Section 5.

1.9.4 [Parties Disagree]

[<<customer\_short\_name>> Version] Fractionalized billing shall apply to all UNEs and Combinations such that recurring charges will be prorated based upon the number of days that the UNEs are in service. Non-recurring charges shall not be fractionalized.

[BellSouth Version] A one-month minimum billing period shall apply to all UNEs, Combinations and Other Services.

## 2 Unbundled Loops

2.1 General

2.1.1 [Parties Disagree]

[<<customer\_short\_name>> Version] BellSouth shall provide <<customer\_short\_name>> with nondiscriminatory access to the local loop on an unbundled basis, in accordance with FCC 47 C.F.R. 51.319(a). **The local loop UNE (Loop) is defined in FCC 47 C.F.R. 51.319(a).** The various Loops that BellSouth **currently offers and** is required to make available are set forth herein.

[BellSouth Version] BellSouth shall provide <<customer\_short\_name>> with nondiscriminatory access to the local loop on an unbundled basis, in accordance with FCC 47 C.F.R. 51.319(a) (Loop). The various Loops that BellSouth is required to make available are set forth herein.

2.1.1.1 [Parties Disagree]

[<<customer\_short\_name>> Version] **No Section.**

[BellSouth Version] **Facilities that do not terminate at a demarcation point at an End User customer premises, including, by way of example, but not**



**limited to, facilities that terminate to another carrier's switch or premises, a cell site, Mobile Switching Center or base station, do not constitute Loops.**

2.1.1.2 [Parties Disagree]

[<<customer\_short\_name>> Version] <<customer\_short\_name>> shall purchase the entire bandwidth of the Loop and, except as required herein **or by Applicable Law**, or as otherwise agreed to by the Parties, BellSouth shall not subdivide the frequency of the Loop.

[BellSouth Version] <<customer\_short\_name>> shall purchase the entire bandwidth of the Loop and, except as required herein or as otherwise agreed to by the Parties, BellSouth shall not subdivide the frequency of the Loop.

2.1.2 [Parties Disagree]

[<<customer\_short\_name>> Version] **There are two categories of UNE Loops: Mass Market Loops and Enterprise Market Loops.**

[BellSouth Version] **No Section.**

2.1.2.1 [Parties Disagree]

[<<customer\_short\_name>> Version] Mass Market Loops deliver narrowband services, such as POTS, facsimile services and DS0 level services as well as certain broadband services such as DSL services to residential and very small business customers. There are three types of Mass Market Loops All Cooper Loops, Fiber-to-the-Home (FTTH) Loops, and Hybrid Fiber/Copper Loops.

[BellSouth Version] Mass Market is as defined by the FCC Order.

2.1.2.2 [Parties Disagree]

[<<customer\_short\_name>> Version] Enterprise Market Loops deliver narrowband and broadband services to small, medium and large sized businesses. Enterprise Loops, including DS1, DS-3/STS-1 Loops, and dark fiber loops, are not subject to any of the restrictions applicable to Mass Market Loops, regardless of the transmission medium they are provided over.

[BellSouth Version] Enterprise Market is as defined by the FCC Order.

2.1.3 The loop shall include the use of all test access functionality, including without limitation, smart jacks, for both voice and data.

2.1.4 The provisioning of a Loop to <<customer\_short\_name>>'s collocation space will require BellSouth to provide cross office cabling and cross connections within the central office to connect the Loop to the demarcation point associated



with the collocation space. These cross connects are separate components that are not considered a part of the Loop, and thus, have a separate charge as set forth in Exhibit A of this Attachment.

2.1.5 Where facilities are available, BellSouth will install Loops in compliance with BellSouth's Products and Services Interval Guide available at the website at <http://www.interconnection.bellsouth.com>. For orders of fifteen (15) or more Loops, the installation and any applicable Order Coordination as described below will be handled on a project basis, and reasonable and nondiscriminatory intervals will be set by the BellSouth project manager for that order. When Loops require a Service Inquiry (SI) prior to issuing the order to determine if facilities are available, the interval for the SI process is separate from the installation interval.

2.1.6 The Loop shall be provided to <<customer\_short\_name>> in accordance with reasonable and nondiscriminatory provisions set forth in BellSouth's TR73600 Unbundled Local Loop Technical Specification and applicable industry standard technical references.

2.1.7 BellSouth will provision, maintain and repair the Loops to the standards that are consistent with the type of Loop ordered.

2.1.8 When a BellSouth technician is required to be dispatched to provision the Loop, BellSouth will tag the Loop with the Circuit ID number and the name of the ordering CLEC. When a dispatch is not required to provision the Loop, BellSouth will tag the Loop on the next required visit to the End User's location. If <<customer\_short\_name>> wants to ensure the Loop is tagged during the provisioning process for Loops that may not require a dispatch (e.g., UVL-SL1, UVL-SL2, and UCL-ND), <<customer\_short\_name>> may order Loop Tagging. Rates for Loop Tagging are as set forth in Exhibit A of this Attachment. The Trouble

2.2 Mass Market Loops

2.2.1 Copper Loops. BellSouth will provide access to unbundled Copper Loops as required by FCC Rule 51.319(a)(1).

2.2.2 Hybrid Loops. BellSouth will provide access to unbundled Hybrid Loops as required by FCC Rule 51.319(a)(2).

2.2.3 [Parties Disagree]

[<<customer\_short\_name>> Version] Fiber-to-the-Home Loops. BellSouth will provide access to unbundled Fiber-to-the-Home Loops as required by FCC Rule 51.319(a)(3). **Unbundling relief contemplated by that rule applies only to Fiber-to-the-Home Loop facilities deployed after October 2, 2003.**

[BellSouth Version] BellSouth will provide access to unbundled Fiber-to-the-Home Loops as required by FCC Rule 51.319(a)(3).

## 2.3 Enterprise Market Loops

2.3.1 DS1 loops. BellSouth shall provide <<customer\_short\_name>> with nondiscriminatory access to a DS1 loop on an unbundled basis. A DS1 loop is a digital local loop having a total digital signal speed of 1.544 megabytes per second. DS1 loops include, but are not limited to, two-wire and four-wire copper loops capable of providing high-bit rate digital subscriber line services, including T1 services.

2.3.2 DS3 loops. BellSouth shall provide <<customer\_short\_name>> with nondiscriminatory access to a DS3 loop on an unbundled basis. A DS3 loop is a digital local loop having a total digital signal speed of 44.736 megabytes per second. <<customer\_short\_name>> may obtain a maximum of two unbundled DS3 loops for any single customer location at the TELRIC-compliant, Commission-approved UNE prices set forth in Exhibit A of this Attachment.

2.3.3 [Parties Disagree]

[<<customer\_short\_name>> Version] Dark Fiber Loops. BellSouth shall provide <<customer\_short\_name>> with nondiscriminatory access to a Dark Fiber Loop on an unbundled basis. Dark Fiber Loop is fiber within an existing fiber optic cable that has not been activated through the use of optronics to render it capable of carrying communications services that extends from the demarcation point at an End User's premises to the BellSouth central office. Dark Fiber Loops may be strands of optical fiber existing in aerial or underground structure.

[BellSouth Version] Dark Fiber Loops. BellSouth shall provide <<customer\_short\_name>> with nondiscriminatory access to a Dark Fiber Loop on an unbundled basis. Dark Fiber Loop is **fiber within an existing fiber optic cable** that has not been activated through the use of optronics to render it capable of carrying communications services that extends from the demarcation point at an End User's premises **and the distribution frame or its equivalent in a** BellSouth central office. Dark Fiber Loops may be strands of optical fiber existing in aerial or underground structure.

## 2.4 Loop Testing/Trouble Reporting

2.4.1 <<customer\_short\_name>> will be responsible for testing and isolating troubles on the Loops. <<customer\_short\_name>> must test and isolate trouble to the BellSouth portion of a designed/non-designed unbundled Loop (e.g., UVL-SL2, UCL-D, UVL-SL1, UCL-ND, etc.) before reporting repair to the UNE Customer Wholesale Interconnection Network Services (CWINS) Center. Upon request from BellSouth at the time of the trouble report, <<customer\_short\_name>> will be required to provide the results of the <<customer\_short\_name>> test which indicate a problem on the BellSouth provided Loop.

2.4.2 Once <<customer\_short\_name>> has isolated a trouble to the BellSouth provided Loop, and had issued a trouble report to BellSouth on the Loop, BellSouth will take the actions necessary to repair the Loop if a trouble actually exists. BellSouth will repair these Loops in a reasonable and nondiscriminatory manner and in time frames that are as favorable as those in which BellSouth repairs similarly situated Loops to its End Users.

2.4.3 [Parties Disagree]

[<<customer\_short\_name Version] If <<customer\_short\_name>> reports a trouble on a non-designed or designed Loop and no trouble actually exists, BellSouth will charge <<customer\_short\_name>> for any dispatching and testing (both inside and outside the CO) required by BellSouth in order to confirm the Loop's working status, **in accordance with TELRIC compliant rates to be approved by the Commission and incorporated in Exhibit A of this Attachment.** If <<customer\_short\_name>> reports the same trouble on the same UNE Loop within thirty (30) calendar days of BellSouth's notification to <<customer\_short\_name>> of its disposition of the prior trouble, and BellSouth is able to determine that such trouble does exist on BellSouth's network, <<customer\_short\_name>> shall be credited on the next billing cycle for charges associated with the prior trouble.

[BellSouth Version] If <<customer\_short\_name>> reports a trouble on a non-designed or designed Loop and no trouble actually exists, BellSouth will charge <<customer\_short\_name>> for any dispatching and testing (both inside and outside the CO) required by BellSouth in order to confirm the Loop's working status. BellSouth will assess the applicable Trouble Determination Charge (TDC) rates from BellSouth's FCC No. 1 Section 13.3.1 for designed circuits, Section A4.3.1 of the GSSTs for Alabama, Kentucky, Louisiana, Mississippi and Tennessee where trouble determination for non-designed circuits is covered under premises work charges, Section A15.4.1 of the GSSTs for Florida and North Carolina where trouble determination for non-designed circuits is covered under trouble location charges, and Section N1.1.2 of the Non-Regulated Services Pricing tariff for Georgia and South Carolina where trouble determination for non-designed circuits is covered under trouble determination charges. If <<customer\_short\_name>> reports the same trouble on the same UNE Loop within thirty (30) calendar days of BellSouth's notification to <<customer\_short\_name>> of its disposition of the prior trouble, and BellSouth is able to determine that such trouble does exist on BellSouth's network, <<customer\_short\_name>> shall be credited on the next billing cycle for charges associated with the prior trouble.

2.4.4 [Parties Disagree]

[<<customer\_short\_name Version] In the event BellSouth must dispatch to the End User's location more than once due to incorrect or incomplete information provided by <<customer\_short\_name>> (e.g., incomplete address, incorrect

contact name/number, etc.), BellSouth will bill <<customer\_short\_name>> for each additional dispatch required to repair the circuit due to the incorrect/incomplete information provided, **in accordance with TELRIC compliant rates to be approved by the Commission and incorporated in Exhibit A of this Attachment.**

[BellSouth Version] In the event BellSouth must dispatch to the End User's location more than once due to incorrect or incomplete information provided by <<customer\_short\_name>> (e.g., incomplete address, incorrect contact name/number, etc.), BellSouth will bill <<customer\_short\_name>> for each additional dispatch required to repair the circuit due to the incorrect/incomplete information provided. BellSouth will assess the applicable Trouble Determination rates from BellSouth's FCC No. 1 Section 13.3.1 for designed circuits, Section A4.3.1 of the GSSTs for Alabama, Kentucky, Louisiana, Mississippi and Tennessee, where trouble determination for non-designed circuits is covered under premises work charges, Section A15.4.1 of the GSSTs for Florida and North Carolina, where trouble determination for non-designed circuits is covered under trouble location charges, and Section N1.1.2 of BellSouth's Non-Regulated Services Pricing tariff for Georgia and South Carolina, where trouble determination for non-designed circuits is covered under trouble determination charges.

2.4.5 BellSouth shall test all Loops at parity in a nondiscriminatory manner. The results of such testing, to the extent available, shall be provided to <<customer\_short\_name>> upon request.

2.5 Order Coordination and Order Coordination-Time Specific

2.5.1 "Order Coordination" (OC) allows BellSouth and <<customer\_short\_name>> to coordinate the installation of the SL2 Loops, Unbundled Digital Loops (UDL) and other Loops where OC may be purchased as an option, to <<customer\_short\_name>>'s facilities to limit End User service outage. OC is available when the Loop is provisioned over an existing circuit that is currently providing service to the End User. OC for physical conversions will be scheduled at BellSouth's discretion during normal working hours on the committed due date. OC shall be provided in accordance with the chart set forth below.

2.5.2 "Order Coordination – Time Specific" (OC-TS) allows <<customer\_short\_name>> to order a specific time for OC to take place. BellSouth will make every effort to accommodate <<customer\_short\_name>>'s specific conversion time request. However, BellSouth reserves the right to negotiate with <<customer\_short\_name>> a conversion time based on load and appointment control when necessary. This OC-TS is a chargeable option for all Loops except Unbundled Copper Loops (UCL) and is billed in addition to the OC charge. <<customer\_short\_name>> may specify a time between 9:00 a.m. and 4:00 p.m. (location time) Monday through Friday (excluding holidays). If <<customer\_short\_name>> specifies a time outside this window, or selects a time

or quantity of Loops that requires BellSouth technicians to work outside normal work hours, overtime charges will apply in addition to the OC and OC-TS charges. Overtime charges will be applied based on the amount of overtime worked and in accordance with the rates established in the Access Services Tariff, Section E13.2, for each state. The OC-TS charges for an order due on the same day at the same location will be applied on a per Local Service Request (LSR) basis.

2.5.3 For a coordinated conversion, i.e., to LNP with loop or to stand alone loop where order coordination is provided for in this agreement, BellSouth shall verbally coordinate the disconnect with <<customer\_short\_name>> and perform any switch translations so as to limit End User service outage. When Order Coordination is provided, BellSouth will call <<customer\_short\_name>> twenty-four (24) to forty-eight (48) hours prior to the actual conversion to ensure <<customer\_short\_name>> will be ready on the due date and to review the details of the cutover. <<customer\_short\_name>> may designate the conversion time when the conversion involves a loop with LNP by ordering Time Specific conversion at rates designated in this agreement. For Time Specific conversions, BellSouth and <<customer\_short\_name>> shall mutually agree upon cut over time and BellSouth will verify the cut over time designated by <<customer\_short\_name>> 24 to 48 hours in advance to ensure that the conversion is to be completed as ordered. Both Parties will use best efforts to ensure that conversions will commence within fifteen (15) minutes of the established time, with the exception of conversions involving IDLC where the Commission has granted extended conversion windows. For coordinated conversions, BellSouth's target intervals for service disruption to the End User is fifteen (15) minutes or less.

	<b>Order Coordination (OC)</b>	<b>Order Coordination – Time Specific (OC-TS)</b>	<b>Test Points</b>	<b>DLR</b>	<b>Charge for Dispatch and Testing if No Trouble Found</b>
<b>SL-1 (Non-Designed)</b>	Chargeable Option	Chargeable Option	Not available	Chargeable Option – ordered as Engineering Information Document	Charged for Dispatch inside and outside Central Office
<b>UCL-ND (Non-Designed)</b>	Chargeable Option	Not Available	Not Available	Chargeable Option – ordered as Engineering Information Document	Charged for Dispatch inside and outside Central Office
<b>Unbundled Voice Loops - SL-2</b>	Included	Chargeable Option	Included	Included	Charged for Dispatch outside Central Office

<b>(including 2- and 4-wire UVL) (Designed)</b>					
<b>Unbundled Digital Loop (Designed)</b>	Included	Chargeable Option (except on Universal Digital Channel)	Included (where appropriate)	Included	Charged for Dispatch outside Central Office
<b>Unbundled Copper Loop (Designed)</b>	Chargeable in accordance with Section 2	Not available	Included	Included	Charged for Dispatch outside Central Office
For UVL-SL1 and UCLs, <<customer_short_name>> must order and will be billed for both OC and OC-TS if requesting OC-TS.					

## 2.6 CLEC to CLEC Conversions for Unbundled Loops

2.6.1 The CLEC to CLEC conversion process, located on BellSouth's web site at <http://www.interconnection.bellsouth.com/guides/unedocs/c2c.pdf>, for unbundled Loops may be used by <<customer\_short\_name>> when converting an existing unbundled Loop from another CLEC for the same End User. The Loop type being converted must be included in <<customer\_short\_name>>'s Interconnection Agreement before requesting a conversion.

2.6.2 To utilize the CLEC to CLEC conversion process, the Loop being converted must be the same Loop type with no requested changes to the Loop, must serve the same End User location from the same serving wire center, and must not require an outside dispatch to provision.

2.6.3 The Loops converted to <<customer\_short\_name>> pursuant to the CLEC to CLEC conversion process shall be provisioned in the same manner and with the same functionality and options as described in this Attachment for the specific Loop type.

## 2.7 Bulk Migration

2.7.1 If <<customer\_short\_name>> requests to migrate twenty-five (25) or more UNE-Port/Loop Combination (UNE-P) customers to UNE-Loop (UNE-L) in the same Central Office on the same due date, <<customer\_short\_name>> must use the Bulk Migration process, which is described in the BellSouth CLEC Information Package, "UNE-Port/Loop Combination (UNE-P) to UNE-Loop (UNE-L) Bulk Migration" located at <http://interconnection.bellsouth.com/guides/unedocs/BulkManpkg.pdf>. The rates for the Bulk Migration process shall be the nonrecurring rates associated with the Loop type being requested in the Bulk Migration asset forth in Exhibit A of this Attachment. Additionally, an electronic OSS charges will apply for each

customer account subject to the Bulk Migration Request. The migration of loops from Integrated Digital Loop Carrier (IDLC) will be done pursuant to Section 2.15 below.

## 2.8 Ordering Guidelines and Processes

2.8.1 Ordering and provisioning for UNEs and Other Services shall be as set forth in Attachment 6.

2.8.2 Additional UNE product information may also be found in the individual CLEC Information Packages found on the “CLEC UNE Products” website located at <http://www.interconnection.bellsouth.com/guides/html/unes.html>.

## 2.9 Unbundled Voice Loops (UVLs)

2.9.1 BellSouth shall make available the following UVLs:

2.9.1.1 2-wire Analog Voice Grade Loop – SL1 (Non-Designed)

2.9.1.2 2-wire Analog Voice Grade Loop – SL2 (Designed)

2.9.1.3 4-wire Analog Voice Grade Loop (Designed)

2.9.2 Unbundled Voice Loops (UVL) may be provisioned using any type of facility that will support voice grade services. This may include loaded copper, non-loaded copper, digital loop carrier systems, fiber/copper combination (hybrid loop) or a combination of any of these facilities. BellSouth, in the normal course of maintaining, repairing, and configuring its network, may also change the facilities that are used to provide any given voice grade circuit. This change may occur at any time and shall result in no voice grade service disruption or degradation to the End User. In these situations, BellSouth will ensure that the newly provided facility will support a 64 kbps channel capable of supporting voice grade services. BellSouth will not guarantee that <<customer\_short\_name>> will be able to continue to provide any advanced services over the new facility. BellSouth will offer UVL in two different service levels - Service Level One (SL1) and Service Level Two (SL2).

2.9.2.1 Unbundled Voice Loop - SL1 (UVL-SL1) Loops are 2-wire Loop start circuits, will be non-designed, and will not have remote access test points. OC will be offered as a chargeable option on SL1 Loops when reuse of existing facilities has been requested by <<customer\_short\_name>>. <<customer\_short\_name>> may also order OC-TS when a specified conversion time is requested. OC-TS is a chargeable option for any coordinated order and is billed in addition to the OC charge. An Engineering Information (EI) document can be ordered as a chargeable option. The EI document provides Loop Make-Up information, which is similar to the information normally provided in a Design Layout Record (DLR). Upon issuance of a non-coordinated order in the service order system,

SL1 Loops will be activated on the due date in the same manner and time frames that BellSouth normally activates POTS-type Loops for its End Users. For SL1 orders that include the OC option, BellSouth will use best efforts to notify <<customer\_short\_name>> within thirty (30) minutes of the completion of the physical wire work.

2.9.2.1.1 For an additional charge BellSouth will make available additional Loop Testing so that <<customer\_short\_name>> may request further testing on new UVL-SL1 Loops. Rates for additional Loop Testing are as set forth in Exhibit A of this Attachment.

2.9.2.2 Unbundled Voice Loop – SL2 (UVL-SL2) Loops may be 2-wire or 4-wire circuits, shall have remote access test points, and will be designed with a DLR provided to <<customer\_short\_name>>. SL2 circuits can be provisioned with loop start, ground start or reverse battery signaling. OC is provided as a standard feature on SL2 Loops. The OC feature will allow <<customer\_short\_name>> to coordinate the installation of the Loop with the disconnect of an existing customer's service and/or number portability service. In these cases, BellSouth will perform the order conversion with standard order coordination at BellSouth's discretion during normal work hours.

## 2.10 Unbundled Digital Loops

2.10.1 BellSouth will offer Unbundled Digital Loops (UDL). UDLs are service specific, will be designed, will be provisioned with test points (where appropriate), and will come standard with OC and a DLR. The various UDLs are intended to support a specific digital transmission scheme or service.

2.10.2 BellSouth shall make available the following UDLs as set forth below:

2.10.2.1 2-wire Unbundled ISDN Digital Loop

2.10.2.2 2-wire Unbundled ADSL Compatible Loop

2.10.2.3 2-wire Unbundled HDSL Compatible Loop

2.10.2.4 4-wire Unbundled HDSL Compatible Loop

2.10.2.5 4-wire Unbundled DS1 Digital Loop

2.10.2.6 4-wire Unbundled Digital Loop/DS0 – 64 kbps, 56 kbps and below

2.10.2.7 DS3 Loop

2.10.2.8 STS-1 Loop

2.10.3 2-Wire Unbundled ISDN Digital Loops will be provisioned according to industry standards for 2-Wire Basic Rate ISDN services and will come standard with a test



point, OC, and a DLR. <<customer\_short\_name>> will be responsible for providing BellSouth with a Service Profile Identifier (SPID) associated with a particular ISDN-capable Loop and End User. With the SPID, BellSouth will be able to adequately test the circuit and ensure that it properly supports ISDN service. When ISDN Loops are provisioned using a Digital Loop Carrier (DLC) system, BellSouth will ensure that the Loops are provisioned on time slots that are compatible with data-only services such as IDSL.

- 2.10.3.1 Upon the Effective Date of this Agreement, Universal Digital Channel (UDC) elements will no longer be offered by BellSouth and no new orders for UDC will be accepted. Any existing UDCs that were provisioned prior to the Effective Date of this Agreement will be grandfathered at the rates set forth in the Parties' interconnection agreement that was in effect immediately prior to the Effective Date of this Agreement. Existing UDCs that were provisioned prior to the Effective Date of this Agreement may remain connected, maintained and repaired according to BellSouth's TR73600 until such time as they are disconnected by <<customer\_short\_name>> or BellSouth provides ninety (90) calendar days notice that such UDC must be terminated at which point the Parties will coordinate the transition in a cooperative manner. <<customer\_short\_name>> may order an ISDN loop, if available, to provide the same functionality as the previously offered UDC product.
- 2.10.4 2-Wire ADSL-Compatible Loop. This is a designed Loop that is provisioned according to Revised Resistance Design (RRD) criteria and may be up to 18,000 feet long and may have up to 6,000 feet of bridged tap (inclusive of Loop length). The Loop is a 2-wire circuit and will come standard with a test point, OC, and a DLR.
- 2.10.5 2-Wire or 4-Wire HDSL-Compatible Loop. This is a designed Loop that meets Carrier Serving Area (CSA) specifications, may be up to 12,000 feet long and may have up to 2,500 feet of bridged tap (inclusive of Loop length). It may be a 2-wire or 4-wire circuit and will come standard with a test point, OC, and a DLR.
- 2.10.6 4-Wire Unbundled DS1 Digital Loop. This is a designed 4-wire Loop that is provisioned according to industry standards for DS1 or Primary Rate ISDN services and will come standard with a test point, OC, and a DLR. A DS1 Loop may be provisioned over a variety of loop transmission technologies including copper, HDSL-based technology or fiber optic transport systems. It will include a 4-Wire DS1 Network Interface at the End User's location.
- 2.10.7 4-Wire Unbundled Digital/DS0 Loop. These are designed 4-wire Loops that may be configured as 64kbps, 56kbps, 19kbps, and other sub-rate speeds associated with digital data services and will come standard with a test point, OC, and a DLR.
- 2.10.8 DS3 Loop. DS3 Loop is a two-point digital transmission path which provides for simultaneous two-way transmission of serial, bipolar, return-to-zero isochronous

digital electrical signals at a transmission rate of 44.736 megabits per second (Mbps) that is dedicated to the use of the ordering CLEC in its provisioning of local exchange and associated exchange access services. It may provide transport for twenty-eight (28) DS1 channels, each of which provides the digital equivalent of twenty-four (24) analog voice grade channels. The interface to unbundled dedicated DS3 transport is a metallic-based electrical interface. DS3 Loops come with a test point and a DLR. DS3 Loops require a Service Inquiry (SI) in order to ascertain availability. Rates are mileage sensitive and the mileage is in airline miles, rounded up and a minimum of one (1) mile applies. BellSouth TR 73501 LightGate<sup>®</sup> Service Interface and Performance Specifications, Issue D, June 1995 applies to DS3 service

- 2.10.9 STS-1 Loop. STS-1 Loop is a high-capacity digital transmission path with SONET VT1.5 mapping that is dedicated for the use of the ordering customer for the purpose of provisioning local exchange and associated exchange access services. It is a two-point digital transmission path that provides for simultaneous two-way transmission of serial bipolar return-to-zero synchronous digital electrical signals at a transmission rate of 51.84 megabits per second (Mbps). It may provide transport for twenty-eight (28) DS1 channels, each of which provides the digital equivalent of twenty-four (24) analog voice grade channels. The interface to unbundled dedicated STS-1 transport is a metallic-based electrical interface. STS-1 Loops come with a test point and a DLR. STS-1 Loops require a Service Inquiry (SI) in order to ascertain availability.
- 2.11 Unbundled Copper Loops (UCL)
- 2.11.1 BellSouth shall make available Unbundled Copper Loops (UCLs). The UCL is a copper twisted pair Loop that is unencumbered by any intervening equipment (e.g., filters, load coils, range extenders, digital loop carrier, or repeaters) and is not intended to support any particular telecommunications service. The UCL will be offered in two types – Designed and Non-Designed.
- 2.11.2 Unbundled Copper Loop – Designed (UCL-D)
- 2.11.2.1 The UCL-D will be provisioned as a dry copper twisted pair (two (2)- or four (4)-wire) Loop that is unencumbered by any intervening equipment (e.g., filters, load coils, range extenders, digital loop carrier, or repeaters).
- 2.11.2.2 A UCL-D will be 18,000 feet or less in length and is provisioned according to Resistance Design parameters, may have up to 6,000 feet of bridged tap and will have up to 1300 Ohms of resistance.
- 2.11.2.3 The UCL-D is a designed circuit, is provisioned with a test point, and comes standard with a DLR. OC is a chargeable option for a UCL-D; however, OC is always required on UCLs where a reuse of existing facilities has been requested by <<customer\_short\_name>>.

- 2.11.2.4 These Loops are not intended to support any particular services and may be utilized by <<customer\_short\_name>> to provide a wide-range of telecommunications services as long as those services do not adversely affect BellSouth's network. This facility will include a Network Interface Device (NID) at the customer's location for the purpose of connecting the Loop to the customer's inside wire. Upon the Effective Date of this Agreement, Unbundled Copper Loop – Long (UCL-L) elements will no longer be offered by BellSouth and no new orders for UCL-L will be accepted. Any existing UCL-Ls that were provisioned prior to the Effective Date of this Agreement will be grandfathered at the rates set forth in the Parties' interconnection agreement that was in effect immediately prior to the Effective Date of this Agreement. Existing UCL-Ls that were provisioned prior to the Effective Date of this Agreement may remain connected, maintained and repaired according to BellSouth's TR73600 and may remain connected until such time as they are disconnected by <<customer\_short\_name>> or BellSouth provides ninety (90) calendar days notice that such UDC must be terminated at which point the Parties will coordinate the transition in a cooperative manner.
- 2.11.3 Unbundled Copper Loop – Non-Designed (UCL-ND)
- 2.11.3.1 The UCL-ND is provisioned as a dedicated 2-wire metallic transmission facility from BellSouth's Main Distribution Frame (MDF) to a customer's premises (including the NID). The UCL-ND will be a "dry copper" facility in that it will not have any intervening equipment such as load coils, repeaters, or digital access main lines (DAMLs), and may have up to 6,000 feet of bridged tap between the End User's premises and the serving wire center. The UCL-ND typically will be 1300 Ohms resistance and in most cases will not exceed 18,000 feet in length, although the UCL-ND will not have a specific length limitation. For Loops less than 18,000 feet and with less than 1300 Ohms resistance, the Loop will provide a voice grade transmission channel suitable for Loop start signaling and the transport of analog voice grade signals. The UCL-ND will not be designed and will not be provisioned with either a DLR or a test point.
- 2.11.3.2 The UCL-ND facilities may be mechanically assigned using BellSouth's assignment systems. Therefore, the Loop Makeup (LMU) process is not required to order and provision the UCL-ND. However, <<customer\_short\_name>> can request LMU for which additional charges would apply.
- 2.11.3.3 For an additional charge, BellSouth also will make available Loop Testing so that <<customer\_short\_name>> may request further testing on the UCL-ND. Rates for Loop Testing are as set forth in Exhibit A of this Attachment.
- 2.11.3.4 UCL-ND Loops are not intended to support any particular service and may be utilized by <<customer\_short\_name>> to provide a wide-range of telecommunications services as long as those services do not adversely affect BellSouth's network. The UCL-ND will include a NID at the customer's location for the purpose of connecting the Loop to the customer's inside wire.

2.11.3.5 OC will be provided as a chargeable option and may be utilized when the UCL-ND provisioning is associated with the reuse of BellSouth facilities. OC-TS does not apply to this product.

2.11.3.6 <<customer\_short\_name>> may use BellSouth's Unbundled Loop Modification (ULM) offering to remove excessive bridged taps and/or load coils from any copper Loop within the BellSouth network. Therefore, some Loops that would not qualify as UCL-ND could be transformed into Loops that do qualify, using the ULM process.

2.12 Unbundled Loop Modifications (Line Conditioning)

2.12.1 [Parties Disagree]

[<<customer\_short\_name>> Version] **BellSouth shall perform line conditioning in accordance with FCC 47 C.F.R. 51.319 (a)(1)(iii). Line Conditioning is as defined in FCC 47 C.F.R. 51.319 (a)(1)(iii)(A). Insofar as it is technically feasible, BellSouth shall test and report troubles for all the features, functions, and capabilities of conditioned copper lines, and may not restrict its testing to voice transmission only.**

[BellSouth Version] Line Conditioning is defined as routine network modification that BellSouth regularly undertakes to provide xDSL services to its own customers. This may include the removal of any device, from a copper Loop or copper sub-loop that may diminish the capability of the Loop or sub-loop to deliver high-speed switched wireline telecommunications capability, including xDSL service. Such devices include, but are not limited to; load coils, low pass filters, and range extenders.

2.12.2 [Parties Disagree]

[<<customer\_short\_name>> Version] **No Section.**

[BellSouth Version] **BellSouth will remove load coils only on copper loops and sub loops that are less than 18,000 feet in length. BellSouth will remove load coils on copper loops and sub loops that are greater than 18,000 feet in length upon <<customer\_short\_name>>'s request at rates pursuant to BellSouth's Special Construction Process contained in BellSouth's FCC No. 2 as mutually agreed to by the Parties.**

2.12.3 [Parties Disagree]

[<<customer\_short\_name>> Version] For any copper loop being ordered by <<customer\_short\_name>> which has over 6,000 feet of combined bridged tap will be modified, upon request from <<customer\_short\_name>>, so that the loop will have a maximum of 6,000 feet of bridged tap. This modification will be performed at no additional charge to <<customer\_short\_name>>. Loop

conditioning orders that require the removal of **other** bridged tap will be performed at the rates set forth in Exhibit A of this Attachment.

[BellSouth Version] For any copper loop being ordered by <<customer\_short\_name>> which has over 6,000 feet of combined bridged tap will be modified, upon request from <<customer\_short\_name>>, so that the loop will have a maximum of 6,000 feet of bridged tap. This modification will be performed at no additional charge to <<customer\_short\_name>>. Loop conditioning orders that require the removal of bridged tap **that serves no network design purpose on a copper loop that will result in a combined level of bridged tap between 2,500 and 6,000 feet** will be performed at the rates set forth in Exhibit A of this Attachment.

2.12.4 [Parties Disagree]

[<<customer\_short\_name Version] No Section.

[BellSouth Version] <<customer\_short\_name>> may request removal of any unnecessary and non-excessive bridged tap (bridged tap between 0 and 2,500 feet which serves no network design purpose), at rates pursuant to BellSouth's Special Construction Process contained in BellSouth's FCC No. 2 as mutually agreed to by the Parties. Rates for ULM are as set forth in Exhibit A of this Attachment.

2.12.5 Rates for ULM are as set forth in Exhibit A of this Attachment.

2.12.6 [Parties Disagree]

[<<customer\_short\_name Version] In those cases where <<customer\_short\_name>> has requested that BellSouth modify a Loop so that it no longer meets the technical parameters of the original Loop type (e.g., voice grade, ISDN, ADSL, etc.), **the resulting modified Loop will be maintained as a UCL.**

[BellSouth's Version] BellSouth will **not** modify a Loop in such a way that it no longer meets the technical parameters of the original Loop type (e.g., voice grade, ADSL, etc.) being ordered.

2.12.7 If <<customer\_short\_name>> requests ULM on a reserved facility for a new loop order, BellSouth may perform a pair change and provision a different loop facility in lieu of the reserved facility with ULM if feasible. The loop provisioned will meet or exceed specifications of the requested loop facility as modified. <<customer\_short\_name>> will not be charged for ULM if a different loop is provisioned. For loops that require a DLR or its equivalent, BellSouth will provide LMU detail of the loop provisioned.

- 2.12.8 <<customer\_short\_name>> shall request Loop make up information pursuant to this Attachment prior to submitting a service inquiry and/or a LSR for the Loop type that <<customer\_short\_name>> desires BellSouth to condition.
- 2.12.9 When requesting ULM for a Loop that BellSouth has previously provisioned for <<customer\_short\_name>>, <<customer\_short\_name>> will submit a service inquiry to BellSouth. If a spare Loop facility that meets the loop modification specifications requested by <<customer\_short\_name>> is available at the location for which the ULM was requested, <<customer\_short\_name>> will have the option to change the Loop facility to the qualifying spare facility rather than to provide ULM. In the event that BellSouth changes the Loop facility in lieu of providing ULM, <<customer\_short\_name>> will not be charged for ULM but will only be charged the service order charges for submitting an order.
- 2.13 Loop Provisioning Involving Integrated Digital Loop Carriers
- 2.13.1 Where <<customer\_short\_name>> has requested an Unbundled Loop and BellSouth uses IDLC systems to provide the local service to the End User and BellSouth has a suitable alternate facility available, BellSouth will make such alternative facilities available to <<customer\_short\_name>>. If a suitable alternative facility is not available, then to the extent it is technically feasible, BellSouth will implement one of the following alternative arrangements for <<customer\_short\_name>> (e.g., hairpinning):
1. Roll the circuit(s) from the IDLC to any spare copper that exists to the customer premises.
  2. Roll the circuit(s) from the IDLC to an existing DLC that is not integrated.
  3. If capacity exists, provide "side-door" porting through the switch.
  4. If capacity exists, provide "Digital Access Cross Connect System (DACS)-door" porting (if the IDLC routes through a DACS prior to integration into the switch).
- 2.13.2 Arrangements 3 and 4 above require the use of a designed circuit. Therefore, non-designed Loops such as the SL1 voice grade and UCL-ND may not be ordered in these cases.
- 2.13.3 If no alternate facility is available, and upon request from <<customer\_short\_name>>, and if agreed to by both Parties, BellSouth may utilize its Special Construction (SC) process to determine the additional costs required to provision facilities. <<customer\_short\_name>> will then have the option of paying the one-time SC rates to place the Loop.
- 2.14 Network Interface Device
- 2.14.1 The NID is defined as any means of interconnection of the End User's customer premises wiring to BellSouth's distribution plant, such as a cross connect device used for that purpose. The NID is a single-line termination device or that portion of a multiple line termination device required to terminate a single line or circuit

at the premises. Unless otherwise requested, all loops will be provisioned with the appropriate Network Interface Device (NID). The NID features two independent chambers or divisions that separate the service provider's network from the End User's customer premises wiring. Each chamber or division contains the appropriate connection points or posts to which the service provider and the End User each make their connections. The NID provides a protective ground connection and is capable of terminating cables such as twisted pair cable.

- 2.14.2 BellSouth shall permit <<customer\_short\_name>> to connect <<customer\_short\_name>>'s loop facilities to the End User's customer premises wiring through the BellSouth NID or at any other technically feasible point.
- 2.14.3 Access to NID
  - 2.14.3.1 <<customer\_short\_name>> may access the End User's customer premises wiring by any of the following means and <<customer\_short\_name>> shall not disturb the existing form of electrical protection and shall maintain the physical integrity of the NID:
    - 2.14.3.1.1 [Parties Disagree]  
[<<customer\_short\_name>> Version] BellSouth shall allow <<customer\_short\_name>> to connect its Loops directly to BellSouth's multi-line residential NID enclosures that have spare terminations available or <<customer\_short\_name>> can connect to terminations that currently have loops attached to them but that are not currently used by BellSouth or any other telecommunications carrier to provide service to the premises.  
[BellSouth Version] BellSouth shall allow <<customer\_short\_name>> to connect its Loops directly to BellSouth's multi-line residential NID enclosures that have spare terminations available or, **in those states where the Commission has so ordered**, <<customer\_short\_name>> can connect to terminations that currently have loops attached to them but that are not currently used by BellSouth or any other telecommunications carrier to provide service to the premises.
  - 2.14.3.1.2 Where an adequate length of the End User's customer premises wiring is present and environmental conditions permit, either Party may remove the customer premises wiring from the other Party's NID and connect such wiring to that Party's own NID, provided that it has received the appropriate consent from the End User and has provided reasonable advanced notice to the other Party.
  - 2.14.3.1.3 Either Party may enter the subscriber access chamber or dual chamber NID enclosures for the purpose of extending a connect divisioned or spliced jumper wire from the customer premises wiring through a suitable "punch-out" hole of such NID enclosures; or

- 2.14.3.1.4 <<customer\_short\_name>> may request BellSouth to make other rearrangements to the End User customer premises wiring terminations or terminal enclosure on a time and materials cost basis.
- 2.14.3.2 In no case shall either Party remove or disconnect the other Party's loop facilities from either Party's NIDs, enclosures, or protectors unless the applicable Commission has expressly permitted the same and the disconnecting Party provides prior notice to the other Party. In such cases, it shall be the responsibility of the Party disconnecting loop facilities to leave undisturbed the existing form of electrical protection and to maintain the physical integrity of the NID. It shall be the responsibility of the Party disconnecting loop facilities to ensure there is no safety hazard, and that party shall hold the other harmless for any liability associated with the removal of the loop facilities from the other Party's NID. Furthermore, it shall be the responsibility of the disconnecting Party, once the other Party's loop has been disconnected from the NID, to reconnect the disconnected loop to a nationally recognized testing laboratory listed station protector, which has been grounded as per Article 800 of the National Electrical Code. If no spare station protector exists in the NID, the disconnected loop must be appropriately cleared, capped and stored.
- 2.14.3.3 <<customer\_short\_name>> shall not remove or disconnect ground wires from BellSouth's NIDs, enclosures, or protectors.
- 2.14.3.4 <<customer\_short\_name>> shall not remove or disconnect NID modules, protectors, or terminals from BellSouth's NID enclosures.
- 2.14.3.5 Due to the wide variety of NID enclosures and outside plant environments, BellSouth will work with <<customer\_short\_name>> to develop specific procedures to establish the most effective means of implementing this Section if the procedures set forth herein do not apply to the NID in question.
- 2.14.4 Technical Requirements
- 2.14.4.1 The NID shall provide an accessible point of interconnection and shall maintain a connection to ground.
- 2.14.4.2 If an existing NID is accessed, it shall be capable of transferring electrical analog or digital signals between the End User's customer premises and the distribution media and/or cross connect to <<customer\_short\_name>>'s NID.
- 2.14.4.3 Existing BellSouth NIDs will be provided in working condition. Where such NID is not functioning properly, BellSouth shall repair the NID at BellSouth's expense. <<customer\_short\_name>> may request BellSouth to do additional work to the NID, including relocating the NID and extending associated distribution plant and inside wiring/UNTW, as appropriate, to that new location, on a time and material basis, except where BellSouth does not charge its retail customers to perform the same functions. When <<customer\_short\_name>>



deploys its own local Loops in a multiple-line termination device, <<customer\_short\_name>> shall specify the quantity of NID connections that it requires within such device.

2.14.4.4 The NID shall be equal to or better than all requirements for NIDs set forth in the applicable industry standard technical requirements.

## 2.15 Sub-loop Elements

2.15.1 Where facilities permit, BellSouth shall offer access to its Unbundled Sub-Loop (USL) elements in accordance with FCC C.F.R. 51.319 (b).

## 2.16 Unbundled Sub-Loop Distribution

2.16.1 The Unbundled Sub-Loop Distribution facility is a dedicated transmission facility that BellSouth provides from an End User's point of demarcation to a BellSouth cross-connect device. The BellSouth cross-connect device may be located within a remote terminal (RT) or a stand-alone cross-box in the field or in the equipment room of a building. The unbundled sub-loop distribution media is a copper twisted pair that can be provisioned as a 2-Wire or 4-Wire facility. BellSouth will make available the following sub-loop distribution offerings where facilities exist:

Unbundled Sub-Loop Distribution – Voice Grade

Unbundled Copper Sub-Loop

Unbundled Sub-Loop Distribution – Intrabuilding Network Cable (aka riser cable)

2.16.1.1 Unbundled Sub-Loop Distribution – Voice Grade (USLD-VG) is a copper sub-loop facility from the cross-box in the field up to and including the point of demarcation at the End User's premises and may have load coils.

2.16.1.2 Unbundled Copper Sub-Loop (UCSL) is a copper facility of any length provided from the cross-box in the field up to and including the End User's point of demarcation. If available, this facility will not have any intervening equipment such as load coils between the End User and the cross-box.

2.16.1.2.1 If <<customer\_short\_name>> requests a UCSL and it is not available, <<customer\_short\_name>> may request the copper Sub-Loop facility be modified pursuant to the ULM process to remove load coils and/or excessive bridged taps. If load coils and/or excessive bridged taps are removed, the facility will be classified as a UCSL.

2.16.1.3 Unbundled Sub-Loop Distribution – Intrabuilding Network Cable (USLD-INC) is the distribution facility owned or controlled by BellSouth inside a building or between buildings on the same property that is not separated by a public street or road. USLD-INC includes the facility from the cross connect device in the building equipment room up to and including the point of demarcation at the End User's premises.

- 2.16.1.3.1 Upon request for USLD-INC from <<customer\_short\_name>>, BellSouth will install a cross connect panel in the building equipment room for the purpose of accessing USLD-INC pairs from a building equipment room. The cross-connect panel will function as a single point of interconnection (SPOI) for USLD-INC and will be accessible by multiple carriers as space permits. BellSouth will place cross-connect blocks in 25-pair increments for <<customer\_short\_name>>'s use on this cross-connect panel. <<customer\_short\_name>> will be responsible for connecting its facilities to the 25-pair cross-connect block(s).
- 2.16.1.4 For access to Voice Grade USLD and UCSL, <<customer\_short\_name>> shall install a cable to the BellSouth cross-box pursuant to the terms and conditions for physical collocation for remote sites set forth in this Agreement. This cable would be connected by a BellSouth technician within the BellSouth cross-box during the set-up process. <<customer\_short\_name>>'s cable pairs can then be connected to BellSouth's USL within the BellSouth cross-box by the BellSouth technician.
- 2.16.1.5 Through the SI process, BellSouth will determine whether access to Unbundled Sub-Loops at the location requested by <<customer\_short\_name>> is technically feasible and whether sufficient capacity exists in the cross-box. If existing capacity is sufficient to meet <<customer\_short\_name>>'s request, then BellSouth will perform the site set-up as described in the CLEC Information Package, located at the website address:  
<http://www.interconnection.bellsouth.com/products/html/un.es.html>.
- 2.16.1.6 The site set-up must be completed before <<customer\_short\_name>> can order sub-loop pairs. For the site set-up in a BellSouth cross-connect box in the field, BellSouth will perform the necessary work to splice <<customer\_short\_name>>'s cable into the cross-connect box. For the site set-up inside a building equipment room, BellSouth will perform the necessary work to install the cross-connect panel and the connecting block(s) that will be used to provide access to the requested USLs.
- 2.16.1.7 Once the site set-up is complete, <<customer\_short\_name>> will request sub-loop pairs through submission of a LSR form to the Local Carrier Service Center (LCSC). OC is required with USL pair provisioning when <<customer\_short\_name>> requests reuse of an existing facility, and the Order Coordination charge shall be billed in addition to the USL pair rate. For expedite requests by <<customer\_short\_name>> for sub-loop pairs, expedite charges will apply for intervals less than five (5) calendar days.
- 2.16.1.8 Unbundled Sub-Loops will be provided in accordance with technical reference TR73600.
- 2.16.2 Unbundled Network Terminating Wire (UNTW)

2.16.2.1 UNTW is unshielded twisted copper wiring that is used to extend circuits from an intra-building network cable terminal or from a building entrance terminal to an individual End User's point of demarcation. It is the final portion of the Loop that in multi-subscriber configurations represents the point at which the network branches out to serve individual subscribers.

2.16.2.2 [Parties Disagree]

[<<customer\_short\_name>> Version] BellSouth will provide this element will be provided in Multi-Dwelling Units (MDUs) and/or Multi-Tenants Units (MTUs) where BellSouth owns, controls or leases multiunit premises wiring.

[BellSouth Version] This element will be provided in Multi-Dwelling Units (MDUs) and/or Multi-Tenants Units (MTUs) where either Party owns or controls wiring all the way to the End Users' premises. Neither Party will provide this element in locations where the property owner provides its own wiring to the End Users' premises or where a third party owns the wiring to the End Users' premises.

2.16.2.3 Requirements

2.16.2.3.1 [Parties Disagree]

[<<customer\_short\_name>> Version] Upon request, BellSouth will provide access to UNTW pairs on an Access Terminal that is suitable for use by multiple carriers at each Garden Terminal or Wiring Closet.

[BellSouth Version] On a multi-unit premises, upon request of the other Party (Requesting Party), the Party owning the network terminating wire (Provisioning Party) will provide access to UNTW pairs on an Access Terminal that is suitable for use by multiple carriers at each Garden Terminal or Wiring Closet.

2.16.2.3.2 [Parties Disagree]

[<<customer\_short\_name>> Version] BellSouth shall not be required to install new or additional NTW beyond existing NTW unless it would do so upon request from one of its own end users or is otherwise required to do so in order to comply with FCC or Commission rules and orders.

[BellSouth Version] The Provisioning Party shall not be required to install new or additional NTW beyond existing NTW to provision the services of the Requesting Party.

2.16.2.3.3 [Parties Disagree]

[<<customer\_short\_name>> Version] No Section.

[BellSouth Version] In existing MDUs and/or MTUs in which BellSouth does not own or control wiring (INC/NTW) to the End Users premises, <<customer\_short\_name>> will install UNTW Access Terminals for BellSouth at no additional charge.

2.16.2.3.4 [Parties Disagree]

[<<customer\_short\_name>> Version] No Section.

[BellSouth Version] In situations in which BellSouth activates a UNTW pair, BellSouth will compensate <<customer\_short\_name>> for each pair activated commensurate to the price specified in <<customer\_short\_name>>'s Agreement.

2.16.2.3.5 [Parties Disagree]

[<<customer\_short\_name>> Version] Upon receipt of an UNTW SI requesting access to **BellSouth's** UNTW pairs at a multi-unit premises, representatives of both Parties will participate in a meeting at the site of the requested access. The purpose of the site visit will include discussion of the procedures for installation and location of the Access Terminals. By request of <<**customer\_short\_name**>>, an Access Terminal will be installed at a single point of interconnection or either adjacent to each (or an individual) **BellSouth** Garden Terminal or inside each (or an individual) **BellSouth** Wiring Closet. <<**customer\_short\_name**>> will deliver and connect its facilities to the UNTW pairs within the Access Terminal. <<**customer\_short\_name**>> may access any available pair on an Access Terminal. A pair is available when a pair is not being utilized to provide service or where the End User has requested a change in its local service provider to <<**customer\_short\_name**>> on that pair. <<**customer\_short\_name**>> shall use commercially reasonable efforts to access only available pairs.

[BellSouth Version] Upon receipt of the UNTW SI requesting access to **the Provisioning Party's** UNTW pairs at a multi-unit premises, representatives of both Parties will participate in a meeting at the site of the requested access. The purpose of the site visit will include discussion of the procedures for installation and location of the Access Terminals. By request of **the Requesting Party**, an Access Terminal will be installed either adjacent to each of **the Provisioning Party's** Garden Terminal or inside each Wiring Closet. **The Requesting Party** will deliver and connect its central office facilities to the UNTW pairs within the Access Terminal. **The Requesting Party** may access any available pair on an Access Terminal. A pair is available when a pair is not being utilized to provide service or where the End User has requested a change in its local service provider to **the Requesting Party** on that pair. **Prior to connecting the Requesting Party's service on a pair previously used by the Provisioning Party, the Requesting Party is responsible for ensuring the End User is no longer using**

**the Provisioning Party's service or another CLEC's service on that pair before accessing UNTW pairs.**

2.16.2.3.6 Access Terminal installation intervals will be established on an individual case basis.

2.16.2.3.7 [Parties Disagree]

[<<customer\_short\_name>> Version] <<customer\_short\_name>> is responsible for obtaining the property owner's permission for **BellSouth** to install an Access Terminal(s) on behalf of <<customer\_short\_name>>. The submission of the SI by <<customer\_short\_name>> will serve as certification by <<customer\_short\_name>> that such permission has been obtained. If the property owner objects to Access Terminal installations that are in progress or **within thirty (30) calendar days of completion** and demands removal of Access Terminals, <<customer\_short\_name>> will be responsible for costs associated with removing Access Terminals and restoring the property to its original state prior to Access Terminals being installed.

[BellSouth Version] **The Requesting Party** is responsible for obtaining the property owner's permission for **the Provisioning Party** to install an Access Terminal(s) on behalf of **the Requesting Party**. The submission of the SI by **the Requesting Party** will serve as certification by **the Requesting Party** that such permission has been obtained. If the property owner objects to Access Terminal installations that are in progress or **subsequent to completion** and demands removal of Access Terminals, **the Requesting Party** will be responsible for costs associated with removing Access Terminals and restoring the property to its original state prior to Access Terminals being installed.

2.16.2.3.8 [Parties Disagree]

[<<customer\_short\_name>> Version] <<customer\_short\_name>> shall indemnify and hold harmless **BellSouth** against any claims of any kind that may arise out of <<customer\_short\_name>>'s failure to obtain the property owner's permission.

[BellSouth Version] **The Requesting Party** shall indemnify and hold harmless **the Provisioning Party** against any claims of any kind that may arise out of **the Requesting Party's** failure to obtain the property owner's permission.

2.16.2.3.9 [Parties Disagree]

[<<customer\_short\_name>> Version] <<customer\_short\_name>> will be billed for nonrecurring and recurring charges for accessing UNTW pairs at the time <<customer\_short\_name>> activates the pair(s). <<customer\_short\_name>> will notify **BellSouth** within five (5) business days of activating UNTW pairs using the LSR form.

**[BellSouth Version]** The Requesting Party will be billed for nonrecurring and recurring charges for accessing UNTW pairs at the time the Requesting Party activates the pair(s). The Requesting Party will notify the Provisioning Party within five (5) business days of activating UNTW pairs using the LSR form.

2.16.2.3.10 [Parties Disagree]

**[<<customer\_short\_name>> Version]** If a trouble exists on a UNTW pair, <<customer\_short\_name>> may use an alternate spare pair that serves that End User if a spare pair is available. In such cases, <<customer\_short\_name>> will re-terminate its existing jumper from the defective pair to the spare pair. Alternatively, <<customer\_short\_name>> will isolate and report troubles to BellSouth. In such cases, <<customer\_short\_name>> must tag the UNTW pair that requires repair. If BellSouth dispatches a technician on a reported trouble call and no UNTW trouble is found, BellSouth will charge <<customer\_short\_name>> for time spent on the dispatch and testing the UNTW pair(s).

**[BellSouth Version]** If a trouble exists on a UNTW pair, the Requesting Party may use an alternate spare pair that serves that End User if a spare pair is available. In such cases, the Requesting Party will re-terminate its existing jumper from the defective pair to the spare pair. Alternatively, the Requesting Party will isolate and report troubles in the manner specified by the Provisioning Party. The Requesting Party must tag the UNTW pair that requires repair. If the Provisioning Party dispatches a technician on a reported trouble call and no UNTW trouble is found, the Provisioning Party will charge the Requesting Party for time spent on the dispatch and testing the UNTW pair(s).

2.16.2.3.11 [Parties Disagree]

**[<<customer\_short\_name>> Version]** If <<customer\_short\_name>> initiates the Access Terminal installation and <<customer\_short\_name>> has not activated at least ten (10) percent of the capacity of the Access Terminal installed pursuant to <<customer\_short\_name>>'s request for an Access Terminal within six (6) months of installation of the Access Terminal, BellSouth will bill <<customer\_short\_name>> a nonrecurring charge equal to the actual cost of provisioning the Access Terminal.

**[BellSouth Version]** If the Requesting Party initiates the Access Terminal installation and the Requesting Party has not activated at least ten (10) percent of the capacity of the Access Terminal installed pursuant to the Requesting Party's request for an Access Terminal within six (6) months of installation of the Access Terminal, the Provisioning Party will bill the Requesting Party a nonrecurring charge equal to the actual cost of provisioning the Access Terminal.

2.16.2.3.12 [Parties Disagree]

[<<customer\_short\_name>> Version] If **BellSouth** determines that <<customer\_short\_name>> is using the UNTW pairs without reporting the activation of the pairs, <<customer\_short\_name>> will be billed for the use of that pair back to the date the End User began receiving service from the <<customer\_short\_name>> at that location. Upon request, <<customer\_short\_name>> will provide copies of its redacted billing record or installation order with sufficient information to substantiate such date. If <<customer\_short\_name>> fails to provide such records, then **BellSouth** will bill <<customer\_short\_name>> back to the date of the Access Terminal installation.

[**BellSouth Version**] If the **Provisioning Party** determines that the **Requesting Party** is using the UNTW pairs without reporting the activation of the pairs, the **Requesting Party** will be billed for the use of that pair back to the date the End User began receiving service from the **Requesting Party** at that location. Upon request, the **Requesting Party** will provide copies of its redacted billing record or installation order with sufficient information to substantiate such date. If the **Requesting Party** fails to provide such records, then the **Provisioning Party** will bill the **Requesting Party** back to the date of the Access Terminal installation.

2.16.3 Unbundled Sub-Loop Feeder

2.16.3.1 Upon the Effective Date of this Agreement, Unbundled Sub-Loop Feeder (USLF) elements will no longer be offered by BellSouth at TELRIC prices. Within ninety (90) calendar days of the Effective Date of this Agreement, <<customer\_short\_name>> will either negotiate market-based rates for these elements or will issue orders to have these elements disconnected. If, after this ninety (90) day period, market-based rates have not been negotiated and <<customer\_short\_name>> has not issued the appropriate disconnect orders, BellSouth may immediately disconnect any remaining USLF elements and will bill <<customer\_short\_name>> any applicable disconnect charges at rates set forth in Exhibit A of this Attachment.

2.16.4 Unbundled Loop Concentration

2.16.4.1 Upon the Effective Date of this Agreement, the Unbundled Loop Concentration (ULC) element will no longer be offered by BellSouth and no new orders for ULC will be accepted. Any existing ULCs that were provisioned prior to the Effective Date of this Agreement will be grandfathered at the rates set forth in the Parties' interconnection agreement that was in effect immediately prior to this Agreement and may remain connected, maintained and repaired according to BellSouth's TR73600 until such time as they are disconnected by <<customer\_short\_name>>, or BellSouth provides ninety (90) calendar days

notice that such ULC must be terminated at which point the Parties will coordinate the transition in a cooperative manner.

2.17 Dark Fiber Loop

2.17.1 Dark Fiber Loop is defined in Section 2.3.3 above. BellSouth will provide line termination elements at both ends but will not provide regeneration or other electronics necessary for <<customer\_short\_name>> to utilize Dark Fiber Loops.

2.17.2 Requirements

2.17.3.1 BellSouth shall make available Dark Fiber Loop where it exists in BellSouth's network and where, as a result of future building or deployment, it becomes available. Dark Fiber Loop will not be deemed available if: (1) it is used by BellSouth for maintenance and repair purposes; (2) it is designated for use pursuant to a firm order placed by another customer; (3) it is restricted for use by all carriers, including BellSouth, because of transmission problems or because it is scheduled for removal due to documented changes to roads and infrastructure; or (4) BellSouth has plans to use the fiber within a two-year planning period. BellSouth is not required to place the fiber for Dark Fiber Loop if none is available.

2.17.3.2 <<customer\_short\_name>> may test the quality of the Dark Fiber to determine its usability and performance specifications.

2.17.3.3 <<customer\_short\_name>> may test Dark Fiber obtained from BellSouth using CLEC or CLEC designated personnel. BellSouth shall provide appropriate interfaces to allow access to Dark Fiber at <<customer\_short\_name>>'s Serving Wire Center and at <<customer\_short\_name>>'s End Users premises.

2.17.3.4 BellSouth shall use commercially reasonable efforts to provide to <<customer\_short\_name>> information regarding the location, availability and performance of Dark Fiber Loop within ten (10) business days after receiving a SI from <<customer\_short\_name>>. Within such time period, BellSouth shall send written confirmation of availability of the Dark Fiber ("Confirmation"). If the requested Dark Fiber Loop is available, BellSouth shall use commercially reasonable efforts to provision the Dark Fiber Loop to <<customer\_short\_name>> within twenty (20) business days after <<customer\_short\_name>> submits a valid, error free LSR. Provisioning includes identification of appropriate connection points (e.g., Light Guide Interconnection (LGX)) to enable <<customer\_short\_name>> to connect <<customer\_short\_name>> provided transmission media (e.g., optical fiber) or equipment to the Dark Fiber Loop.

2.17.3.5 [Parties Disagree]



[<<customer\_short\_name>> Version] BellSouth shall provide access to Dark Fiber Loops for test access and testing at **any technically feasible point**, the termination point within <<customer\_short\_name>>'s Serving Wire Center and at <<customer\_short\_name>>'s End User's premises.

[BellSouth Version] BellSouth shall provide access to Dark Fiber Loop for test access and testing at the termination point within <<customer\_short\_name>>'s Serving Wire Center and at <<customer\_short\_name>>'s End User's premises.

2.17.3.6 If requested dark fiber has any lightwave repeater equipment interspliced to it, BellSouth will remove such equipment at <<customer\_short\_name>>'s request subject to time and materials charges.

2.18 Loop Makeup

2.18.1 Description of Service

2.18.1.1 BellSouth shall make available to <<customer\_short\_name>> LMU information so that <<customer\_short\_name>> can make an independent judgment about whether the Loop is capable of supporting the advanced services equipment <<customer\_short\_name>> intends to install and the services <<customer\_short\_name>> wishes to provide. This Section addresses LMU as a preordering transaction, distinct from <<customer\_short\_name>> ordering any other service(s). Loop Makeup Service Inquiries (LMUSI) and mechanized LMU queries are likewise unique from other preordering functions with associated SIs as described in this Agreement.

2.18.1.2 BellSouth will provide <<customer\_short\_name>> LMU information consisting of the composition of the Loop material (copper/fiber); the existence, location and type of equipment on the Loop, including but not limited to digital loop carrier or other remote concentration devices, feeder/distribution interfaces, bridged taps, load coils, pair-gain devices; the Loop length; the wire gauge and electrical parameters.

2.18.1.3 BellSouth's LMU information is provided to <<customer\_short\_name>> as it exists either in BellSouth's databases or in its hard copy facility records. BellSouth does not guarantee accuracy or reliability of the LMU information provided, but BellSouth shall provide to <<customer\_short\_name>> the same information that it would provide to itself.

2.18.1.4 [Parties Disagree]

[<<customer\_short\_name >> Version] **No Section.**

[BellSouth Version] **BellSouth's provisioning of LMU information to the requesting CLEC for facilities is contingent upon either BellSouth or the requesting CLEC controlling the Loop(s) that serve the service location for which LMU information has been requested by the CLEC. The requesting**

**CLEC is not authorized to receive LMU information on a facility used or controlled by another CLEC unless BellSouth receives a Letter of Authorization (LOA) from the voice CLEC (owner) or its authorized agent on the LMUSI submitted by the requesting CLEC.**

- 2.18.1.5 <<customer\_short\_name>> may choose to use equipment that it deems will enable it to provide a certain type and level of service over a particular BellSouth Loop as long as that equipment does not disrupt other services on the BellSouth network. The determination shall be made solely by <<customer\_short\_name>> and BellSouth shall not be liable in any way for the performance of the advanced data services provisioned over said Loop. The specific Loop type (ADSL, HDSL, or otherwise) ordered on the LSR must match the LMU of the Loop reserved taking into consideration any requisite line conditioning. The LMU data is provided for informational purposes only and does not guarantee <<customer\_short\_name>>'s ability to provide advanced data services over the ordered Loop type. Further, if <<customer\_short\_name>> orders Loops that do not require a specific facility medium or Loops that are not intended to support advanced services (such as UVL-SL1, UVL-SL2) and that are not inventoried as advanced services Loops, the LMU information for such Loops is subject to change at any time due to modifications and/or upgrades to BellSouth's network. <<customer\_short\_name>> is fully responsible for any of its service configurations that may differ from BellSouth's technical standard for the Loop type ordered.
- 2.18.2 Submitting Loop Makeup Service Inquiries
- 2.18.2.1 <<customer\_short\_name>> may obtain LMU information by submitting a mechanized LMU query or a Manual LMUSI. Mechanized LMUs should be submitted through BellSouth's OSS interfaces. After obtaining the Loop information from the mechanized LMU process, if <<customer\_short\_name>> needs further Loop information in order to determine Loop service capability, <<customer\_short\_name>> may initiate a separate Manual Service Inquiry for a separate nonrecurring charge as set forth in Exhibit A of this Attachment.
- 2.18.2.2 Manual LMUSIs shall be submitted according to the guidelines in the LMU CLEC Information Package available at <http://interconnection.bellsouth.com/guides/html/unes.html>. The service interval for the return of a Manual LMUSI is three (3) business days. Manual LMUSIs are not subject to expedite requests. This service interval is distinct from the interval applied to the subsequent service order.
- 2.18.3 Loop Reservations
- 2.18.3.1 For a Mechanized LMUSI, <<customer\_short\_name>> may reserve up to ten (10) Loop facilities. For a Manual LMUSI, <<customer\_short\_name>> may reserve up to three (3) Loop facilities.

- 2.18.3.2 <<customer\_short\_name>> may reserve facilities for up to four (4) business days for each facility requested through LMU from the time the LMU information is returned to <<customer\_short\_name>>. During and prior to <<customer\_short\_name>> placing an LSR, the reserved facilities are rendered unavailable to other customers, including BellSouth. If <<customer\_short\_name>> does not submit an LSR for a UNE service on a reserved facility within the four (4) business day reservation timeframe, the reservation of that spare facility will become invalid and the facility will be released.
- 2.18.3.3 Charges for preordering Manual LMUSI or Mechanized LMU are separate from any charges associated with ordering other services from BellSouth.
- 2.18.3.4 All LSRs issued for reserved facilities shall reference the facility reservation number as provided by BellSouth. <<customer\_short\_name>> will not be billed any additional LMU charges for the Loop ordered on such LSR. If, however, <<customer\_short\_name>> does not reserve facilities upon an initial LMUSI, <<customer\_short\_name>>'s placement of an order for an advanced data service type facility will incur the appropriate billing charges to include SI and reservation per Exhibit A of this Attachment.
- 2.18.3.5 Where <<customer\_short\_name>> has reserved multiple Loop facilities on a single reservation, <<customer\_short\_name>> may not specify which facility shall be provisioned when submitting the LSR. For those occasions, BellSouth will assign to <<customer\_short\_name>>, subject to availability, a facility that meets the BellSouth technical standards of the BellSouth type Loop as ordered by <<customer\_short\_name>>.

### **3 Line Sharing**

#### **3.1 General**

- 3.1.1 Line Sharing is defined as the process by which <<customer\_short\_name>> provides digital subscriber line service over the same copper loop that BellSouth uses to provide voice service, with BellSouth using the low frequency portion of the loop and <<customer\_short\_name>> using the high frequency spectrum (as defined below) of the loop.
- 3.1.2 Line Sharing arrangements in service as of October 1, 2003, will be grandfathered until such End User cancels or otherwise discontinues its subscription to the DSL service of <<customer\_short\_name>>, or its successor or its assign. Grandfathered arrangements pursuant to this Section will be billed at the rates set forth in Exhibit A of this Attachment.
- 3.1.3 For the period from October 2, 2003, through October 1, 2004, <<customer\_short\_name>> may request new Line Sharing arrangements. For Line Sharing arrangements placed in service between October 2, 2003, and

October 1, 2004, the rates will be as set forth in Exhibit A of this Attachment. After October 1, 2004, <<customer\_short\_name>> may not request new Line Sharing arrangements under the terms of this Agreement.

- 3.1.4 The rates set forth herein will be applied retroactively back to the date set forth in the Triennial Review Order.
- 3.1.5 As of the earlier of October 2, 2006, or the date that the End User cancels or otherwise discontinues its subscription to the DSL service with <<customer\_short\_name>>, its successors or its assign, all Line Sharing arrangements pursuant to Section 2.21.1.3 above of this Attachment shall be terminated.
- 3.1.6 The High Frequency Spectrum is defined as the frequency range on a copper Loop above the range that carries analog circuit-switched voice transmissions. Access to the High Frequency Spectrum is intended to allow <<customer\_short\_name>> the ability to provide Digital Subscriber Line (xDSL) data services to the End User for which BellSouth provides voice services. The High Frequency Spectrum shall be available for any version of xDSL complying with Spectrum Management Class 5 of ANSI T1.417, American National Standard for Telecommunications, Spectrum Management for Loop Transmission Systems. BellSouth will continue to have access to the low frequency portion of the Loop spectrum (from 300 Hertz to at least 3000 Hertz, and potentially up to 3400 Hertz, depending on equipment and facilities) for the purposes of providing voice service. <<customer\_short\_name>> shall only use xDSL technology that is within the PSD mask for Spectrum Management Class 5 as found in the above-mentioned document.
- 3.1.7 Access to the High Frequency Spectrum requires an unloaded, 2-wire copper Loop. An unloaded Loop is a copper Loop with no load coils, low-pass filters, range extenders, DAMLs, or similar devices and minimal bridged taps consistent with ANSI T1.413 and T1.601.
- 3.1.8 When ordering line sharing, BellSouth will provide Loop Modification to <<customer\_short\_name>> on an existing Loop in accordance with procedures as specified in Section 2.12 above. High Frequency Spectrum Unbundled Loop Modification is a separate distinct service from Unbundled Loop Modification set forth in Section 2.12 above. Procedures for High Frequency Spectrum (CO Based) Unbundled Loop Modification may be found on the web at: [http://www.interconnection.bellsouth.com/guides/unedocs/hi\\_freq\\_sp\\_ulm.pdf](http://www.interconnection.bellsouth.com/guides/unedocs/hi_freq_sp_ulm.pdf). Nonrecurring rates for this offering are as set forth in Exhibit A of this Attachment.
- 3.1.9 Where <<customer\_short\_name>> is seeking access to the high frequency portion of a copper loop or copper subloop pursuant to paragraphs (a) and (b) of FCC Rule 51.319 and BellSouth claims that conditioning that loop or subloop will significantly degrade, as defined in FCC Rule 51.233, the voiceband services that

BellSouth is currently providing over that loop or subloop, BellSouth must either: (1) Locate another copper loop or copper subloop that has been or can be conditioned, migrate BellSouth's voiceband service to that loop or subloop, and provide <<customer\_short\_name>> with access to the high frequency portion of that alternative loop or subloop; or (2) Make a showing to the Commission that the original copper loop or copper subloop cannot be conditioned without significantly degrading voiceband services on that loop or subloop, as defined in FCC Rule 51.233, and that there is no adjacent or alternative copper loop or copper subloop available that can be conditioned or to which the End User's voiceband service can be moved to enable line sharing. If, after evaluating BellSouth's showing under paragraph FCC Rule 51.319 (a)(1)(iii)(D)(2), the Commission concludes that a copper loop or copper subloop cannot be conditioned without significantly degrading the voiceband service, BellSouth cannot then or subsequently condition that loop or subloop to provide advanced services to its own customers without first making available to any requesting telecommunications carrier the high frequency portion of the newly conditioned loop or subloop.

- 3.1.10 Line Sharing shall only be available on Loops on which BellSouth is also providing, and continues to provide, analog voice service directly to the End User. In the event the End User terminates its BellSouth provided voice service for any reason, or in the event BellSouth disconnects the End User's voice service pursuant to its tariffs or applicable law, and <<customer\_short\_name>> desires to continue providing xDSL service on such Loop, <<customer\_short\_name>> shall be required to purchase a full stand-alone Loop UNE or establish a Line Splitting arrangement with another LEC. To the extent commercially practicable, BellSouth shall give <<customer\_short\_name>> notice in a reasonable time prior to disconnect, which notice shall give <<customer\_short\_name>> an adequate opportunity to notify BellSouth of its intent to purchase such Loop. In those cases in which BellSouth no longer provides voice service to the End User and <<customer\_short\_name>> purchases the full stand-alone Loop, <<customer\_short\_name>> may elect the type of Loop it will purchase. <<customer\_short\_name>> will pay the appropriate recurring and nonrecurring rates for such Loop as set forth in Exhibit A of this Attachment.
- 3.1.11 If <<customer\_short\_name>> reports a trouble on the High Frequency Spectrum of a Loop and no trouble actually exists on the BellSouth portion, BellSouth will charge <<customer\_short\_name>> for any dispatching and testing (both inside and outside the CO) required by BellSouth in order to confirm the working status. The rates charged for no trouble found (NTF) shall be as set forth in Exhibit A of this Attachment.
- 3.1.12 Only one CLEC shall be permitted unbundled access to the High Frequency Spectrum of any particular Loop.
- 3.2 Provisioning of Line Sharing and Splitter Space

- 3.2.1 BellSouth will provide <<customer\_short\_name>> with access to the High Frequency Spectrum as follows:
- 3.2.1.1 To order High Frequency Spectrum on a particular Loop, <<customer\_short\_name>> must have a Digital Subscriber Line Access Multiplexer (DSLAM) collocated in the central office that serves the End User of such Loop.
- 3.2.1.2 <<customer\_short\_name>> may provide its own splitters or may order splitters in a central office once it has installed its DSLAM in that central office. BellSouth will install splitters within thirty-six (36) calendar days of <<customer\_short\_name>>'s submission of an error free Line Splitter Ordering Document (LSOD) to the BellSouth Complex Resale Support Group.
- 3.2.1.3 Once a splitter is installed on behalf of <<customer\_short\_name>> in a central office in which <<customer\_short\_name>> is located, <<customer\_short\_name>> shall be entitled to order the High Frequency Spectrum on lines served out of that central office. BellSouth will bill and <<customer\_short\_name>> shall pay the electronic or manual ordering charges as applicable when <<customer\_short\_name>> orders High Frequency Spectrum for End User service.
- 3.2.1.4 BellSouth shall test the data portion of the Loop to ensure the continuity of the wiring for <<customer\_short\_name>>'s data.
- 3.3 BellSouth Provided Splitter – Line Sharing
- 3.3.1 BellSouth will select, purchase, install, and maintain a central office POTS splitter and provide <<customer\_short\_name>> access to data ports on the splitter. The splitter will route the High Frequency Spectrum on the circuit to <<customer\_short\_name>>'s xDSL equipment in <<customer\_short\_name>>'s collocation space. At least thirty (30) calendar days before making a change in splitter suppliers, BellSouth will provide <<customer\_short\_name>> with a carrier notification letter, informing <<customer\_short\_name>> of change. <<customer\_short\_name>> shall purchase ports on the splitter in increments of eight (8), twenty-four (24), or ninety-six (96) ports in Alabama, Florida, Georgia, Kentucky, Louisiana, Mississippi, North Carolina and South Carolina. <<customer\_short\_name>> shall purchase ports on the splitter in increments of twenty-four (24) or ninety-six (96) ports in Tennessee.
- 3.3.2 BellSouth will install the splitter in (i) a common area close to <<customer\_short\_name>>'s collocation area, if possible; or (ii) in a BellSouth relay rack as close to <<customer\_short\_name>>'s DS0 termination point as possible. <<customer\_short\_name>> shall have access to the splitter for test purposes, regardless of where the splitter is placed in the BellSouth premises. For purposes of this Section, a common area is defined as an area in the central office in which both Parties have access to a common test access point. A Termination

Point is defined as the point of termination for <<customer\_short\_name>> on the main distributing frame in the central office and is not the demarcation point set forth in Attachment 4 of this Agreement. BellSouth will cross-connect the splitter data ports to a specified <<customer\_short\_name>> DS0 at such time that a <<customer\_short\_name>> End User's service is established.

### 3.4 CLEC Provided Splitter – Line Sharing

3.4.1 <<customer\_short\_name>> may at its option purchase, install and maintain central office POTS splitters in its collocation arrangements. <<customer\_short\_name>> may use such splitters for access to its customers and to provide digital line subscriber services to its customers using the High Frequency Spectrum. Existing Collocation rules and procedures and the terms and conditions relating to Collocation set forth in Attachment 4-Central Office shall apply.

3.4.2 Any splitters installed by <<customer\_short\_name>> in its collocation arrangement shall comply with ANSI T1.413, Annex E splitter Standards. <<customer\_short\_name>> may install any splitters that BellSouth deploys or permits to be deployed for itself or any BellSouth affiliate.

### 3.5 Ordering – Line Sharing

3.5.1 <<customer\_short\_name>> shall use BellSouth's LSOD to order splitters from BellSouth and to activate and deactivate DS0 Collocation Connecting Facility Assignments (CFA) for use with High Frequency Spectrum.

3.5.2 BellSouth will provide <<customer\_short\_name>> the LSR format to be used when ordering the High Frequency Spectrum.

3.5.3 BellSouth will provision High Frequency Spectrum in compliance with BellSouth's Products and Services Interval Guide available at the website at <http://www.interconnection.bellsouth.com>.

3.5.4 BellSouth will provide <<customer\_short\_name>> access to Preordering LMU in accordance with the terms of this Agreement. BellSouth shall bill and <<customer\_short\_name>> shall pay the rates for such services, as described in Exhibit A of this Attachment.

### 3.6 Maintenance and Repair – Line Sharing

3.6.1 <<customer\_short\_name>> shall have access for repair and maintenance purposes to any Loop for which it has access to the High Frequency Spectrum. If <<customer\_short\_name>> is using a BellSouth owned splitter, <<customer\_short\_name>> may access the Loop at the point where the combined voice and data signal exits the central office splitter via a bantam test jack. If

<<customer\_short\_name>> provides its own splitter, it may test from the collocation space or the Termination Point.

3.6.2 BellSouth will be responsible for repairing voice services and the physical line between the NID at the customer's premises and the Termination Point. <<customer\_short\_name>> will be responsible for repairing data services. Each Party will be responsible for maintaining its own equipment.

3.6.3 <<customer\_short\_name>> shall inform its End Users to direct data problems to <<customer\_short\_name>>, unless both voice and data services are impaired, in which event the End Users should call BellSouth.

3.6.4 Once a Party has isolated a trouble to the other Party's portion of the Loop, the Party isolating the trouble shall notify the End User that the trouble is on the other Party's portion of the Loop.

3.6.5 [Parties Disagree]

[<<customer\_short\_name>> Version] When BellSouth receives a voice trouble and isolates the trouble to the physical collocation arrangement belonging to <<customer\_short\_name>>, BellSouth will notify <<customer\_short\_name>>. **<<customer\_short\_name>> will provide at least one (1) but no more than two (2) verbal CFA pair changes to BellSouth in an attempt to resolve the voice trouble. In the event a CFA pair change resolves the voice trouble, <<customer\_short\_name>> will provide BellSouth an LSR with the new CFA pair information within twenty-four (24) hours (excluding Saturdays, Sundays and Holidays) of receiving notification from BellSouth of such resolution. No charges will apply for submission of such LSR. If <<customer\_short\_name>> fails to respond to a BellSouth request for verbal CFA pair changes within twenty-four (24) hours (excluding Saturdays, Sundays and Holidays) of <<customer\_short\_name>>'s Maintenance Service Center receiving notification from BellSouth, BellSouth may suspend <<customer\_short\_name>>'s access to the High Frequency Spectrum on such Loop.**

[BellSouth Version] Notwithstanding anything else to the contrary in this Agreement, when BellSouth receives a voice trouble and isolates the trouble to the physical collocation arrangement belonging to <<customer\_short\_name>>**or is unable to detect a trouble**, BellSouth will notify <<customer\_short\_name>> **and bill <<customer\_short\_name>> accordingly.** BellSouth will not be responsible for any loss of data as a result of this action.

3.7 Line Splitting

3.7.1 BellSouth will provide Line splitting in accordance with FCC 47 C.F.R. 51.319 (a)(1)(ii).



- 3.7.2 In the event <<customer\_short\_name>> provides its own switching or obtains switching from a third party, <<customer\_short\_name>> may engage in line splitting arrangements with another LEC using a splitter, provided by <<customer\_short\_name>>, in a Collocation Arrangement at the central office where the loop terminates into a distribution frame or its equivalent.
- 3.7.3 Where <<customer\_short\_name>> is purchasing a UNE-port and a UNE-loop, BellSouth shall offer line splitting pursuant to the following Sections in this Attachment.
- 3.7.4 <<customer\_short\_name>> shall provide BellSouth with a signed LOA between it and the Data LEC or Voice LEC with which it desires to provision Line Splitting services.
- 3.7.5 End Users currently receiving voice service from a Voice LEC through a UNE-P may be converted to Line Splitting arrangements by <<customer\_short\_name>> or its authorized agent ordering Line Splitting Service. If the CLEC wishes to provide the splitter, the UNE-P arrangement will be converted to a stand-alone UNE Loop, a UNE port, two collocation cross connects and the high frequency spectrum line activation. If BellSouth owns the splitter, the UNE-P arrangement will be converted to a stand-alone UNE Loop, port, and one collocation cross connection.
- 3.7.6 When End Users on Loops using High Frequency Spectrum CO Based line sharing service are converted to Line Splitting, BellSouth will discontinue billing <<customer\_short\_name>> for the High Frequency Spectrum. BellSouth will continue to bill the Data LEC for all associated splitter charges if the Data LEC continues to use a BellSouth splitter. It is the responsibility of <<customer\_short\_name>> or its authorized agent to determine if the Loop is compatible for Line Splitting Service. <<customer\_short\_name>> or its authorized agent may use the existing Loop unless it is not compatible with the Data LEC's data service and <<customer\_short\_name>> or its authorized agent submits an LSR to BellSouth to change the Loop.
- 3.8 Provisioning Line Splitting and Splitter Space
- 3.8.1 The Data LEC, Voice LEC or BellSouth may provide the splitter. When <<customer\_short\_name>> or its authorized agent owns the splitter, Line Splitting requires the following: a non-designed analog Loop from the serving wire center to the NID at the End User's location; a collocation cross connection connecting the Loop to the collocation space; a second collocation cross connection from the collocation space connected to a voice port; the high frequency spectrum line activation, and a splitter. The Loop and port cannot be a Loop and port combination (i.e., UNE-P), but must be individual stand-alone Network Elements. When BellSouth owns the splitter, Line Splitting requires the following: a non designed analog Loop from the serving wire center to the NID

at the End User's location with CFA and splitter port assignments, and a collocation cross connection from the collocation space connected to a voice port.

- 3.8.2 An unloaded 2-wire copper Loop must serve the End User. The meet point for the Voice LEC and the Data LEC is the point of termination on the MDF for the Data LEC's cable and pairs.
- 3.8.3 The foregoing procedures are applicable to migration to Line Splitting Service from a UNE-P arrangement, BellSouth Retail Voice Service, BellSouth High Frequency Spectrum (CO Based) Line Sharing.
- 3.8.4 For other migration scenarios to line splitting, BellSouth will work cooperatively with CLECs to develop methods and procedures to develop a process whereby a Voice CLEC and a Data LEC may provide services over the same Loop.
- 3.9 Ordering – Line Splitting
  - 3.9.1 <<customer\_short\_name>> shall use BellSouth's LSOD to order splitters from BellSouth and to activate and deactivate DS0 Collocation CFA for use with Line Splitting.
  - 3.9.2 BellSouth shall provide <<customer\_short\_name>> the LSR format to be used when ordering Line Splitting service.
  - 3.9.3 BellSouth will provision Line Splitting service in compliance with BellSouth's Products and Services Interval Guide available at the website at <http://www.interconnection.bellsouth.com>.
  - 3.9.4 BellSouth will provide <<customer\_short\_name>> access to Preordering LMU in accordance with the terms of this Agreement. BellSouth shall bill and <<customer\_short\_name>> shall pay the rates for such services as described in Exhibit A of this Attachment.
  - 3.9.5 When ordering Line Splitting, BellSouth will provide Loop Modification to <<customer\_short\_name>> on an existing Loop in accordance with procedures as specified in Section 2.12 above. High Frequency Spectrum Unbundled Loop Modification is a separate distinct service from Unbundled Loop Modification set forth in Section 2.12 above. Procedures for High Frequency Spectrum Unbundled Loop Modification may be found on the web at: [http://www.interconnection.bellsouth.com/guides/unedocs/hi\\_freq\\_sp\\_ulm.pdf](http://www.interconnection.bellsouth.com/guides/unedocs/hi_freq_sp_ulm.pdf). Nonrecurring rates for this offering are as set forth in Exhibit A of this Attachment.
- 3.10 Maintenance – Line Splitting
  - 3.10.1 BellSouth will be responsible for repairing voice services and the physical loop between the NID at the customer's premises and the termination point.

<<customer\_short\_name>> will be responsible for maintaining the voice and data services. Each Party will be responsible for maintaining its own equipment.

3.10.2 <<customer\_short\_name>> shall inform its End Users to direct all problems to <<customer\_short\_name>> or its authorized agent.

3.10.3 [Parties Disagree]

[<<customer\_short\_name>> Version] If <<customer\_short\_name>> is **purchasing line splitting and it is not the data provider**, <<customer\_short\_name>> shall indemnify, defend and hold harmless BellSouth from and against any claims, losses, actions, causes of action, suits, demands, damages, injury, and costs including reasonable attorney fees **reasonably arising or resulting from the actions taken by the data provider in connection with the line splitting arrangement, except to the extent caused by BellSouth's gross negligence or willful misconduct.**

[BellSouth Version] If <<customer\_short\_name>> is **not the data provider**, <<customer\_short\_name>> shall indemnify, defend and hold harmless BellSouth from and against any claims, losses, actions, causes of action, suits, demands, damages, injury, and costs including reasonable attorney fees, **which arise out of actions related to the data provider.**

3.10.4 [Parties Disagree]

[<<customer\_short\_name>> Version] **In cases where <<customer\_short\_name>> purchases UNEs from BellSouth, BellSouth shall not refuse to provide DSL transport or DSL services (of any kind) to <<customer\_short\_name>> and its End Users, unless BellSouth has been expressly permitted to do so by the Commission. Where BellSouth provides such transport or services to <<customer\_short\_name>> and its End Users, BellSouth shall do so without charge until such time as it produces an amendment proposal and the Parties amend this Agreement to incorporate terms that are no less favorable, in any respect, than the rates, terms and conditions pursuant to which BellSouth provides such transport and services to any other entity.**

[BellSouth Version] **No Section.**

#### **4 Local Switching**

4.1 BellSouth shall provide non-discriminatory access to local circuit switching capability and local tandem switching capability in accordance with FCC Rule 51.319 (d).

4.2 Local Circuit Switching Capability, including Tandem Switching Capability

4.2.1 Local circuit switching capability is defined as all line-side and trunk-side facilities, plus the features, functions, and capabilities of the switch. The features, functions, and capabilities of the switch shall include the basic switching function of connecting lines to lines, lines to trunks, trunks to lines, and trunks to trunks. Local circuit switching includes all vertical features that the switch is capable of providing, including custom calling, custom local area signaling service features, and Centrex, as well as any technically feasible customized routing functions. In addition, the features, functions, and capabilities of the local circuit switching UNE also include the same basic capabilities that are available to BellSouth's customers, such as telephone number, directory listing, dial tone, signaling, and access to 911, and, in association with the provision by BellSouth of the local circuit switching UNE, operator services, directory assistance and call related databases (via signaling). Switch routing tables are included as a function of the switch.

4.2.2 [Parties Disagree]

[<<customer\_short\_name>> Version] Notwithstanding BellSouth's general duty to unbundle local circuit switching, BellSouth shall not be required to unbundle local circuit switching for <<customer\_short\_name>> when <<customer\_short\_name>> serves an End User with: **(a)** four (4) or more voice-grade (DS0) equivalents or lines served by BellSouth in Zone 1 of one of the following MSAs: Atlanta, GA; Miami, FL; Orlando, FL; Ft. Lauderdale, FL; Charlotte-Gastonia-Rock Hill, NC; Greensboro-Winston Salem-High Point, NC; Nashville, TN; and New Orleans, LA; or **(b)** a DS1 or higher capacity Loop. To the extent that <<customer\_short\_name>> is serving any End User as described in **(b)** above, <<customer\_short\_name>> **must submit orders to terminate such arrangement or converted such arrangement to non-UNE pricing as of April 1, 2004 or the Effective Date, if such date is later than April 1, 2004.**

[BellSouth Version] Notwithstanding BellSouth's general duty to unbundle local circuit switching, BellSouth shall not be required to unbundle local circuit switching for <<customer\_short\_name>> when <<customer\_short\_name>>: **(1)** serves an End User with four (4) or more voice-grade (DS0) equivalents or lines served by BellSouth in Zone 1 of one of the following MSAs: Atlanta, GA; Miami, FL; Orlando, FL; Ft. Lauderdale, FL; Charlotte-Gastonia-Rock Hill, NC; Greensboro-Winston Salem-High Point, NC; Nashville, TN; and New Orleans, LA; or **(2) serves an End User with a DS1 or higher capacity Loop in any service area covered by this Agreement.** To the extent that <<customer\_short\_name>> is serving any End User as described in **(2)** above **as of October 2, 2003, such arrangement may not remain in place any longer than April 1, 2004, after which time such arrangement must be terminated by <<customer\_short\_name>> or BellSouth shall convert such arrangement to tariff pricing.**

- 4.2.3 Rates for unbundled switching at the DS1 level and above or for combinations with unbundled switching at the DS1 level and above provisioned prior to the Effective Date of this Agreement shall be those rates set forth in Exhibit A of this Attachment until April 1, 2004. The filing of this Agreement with the applicable Commission shall constitute the filing of the joint DS1-UNE-P transition plan as required by paragraph 531 of the FCC's Triennial Review Order.
- 4.2.4 Local Switching that is not required to be provided as a UNE but is required pursuant to Section 271 of the Act will be provided pursuant to a separate agreement or tariff, unless the FCC or Commission finds such provisions are properly included in a Section 251 interconnection agreement in which case the Parties shall negotiate an amendment to this Agreement.
- 4.2.5 Unbundled Local Switching consists of three separate unbundled elements: Unbundled Ports, End Office Switching Functionality, and End Office Interoffice Trunk Ports.
- 4.2.6 Unbundled Local Switching combined with Common Transport and, if necessary, Tandem Switching provides to <<customer\_short\_name>>'s End User local calling and the ability to presubscribe to a primary carrier for intraLATA toll service and/or to presubscribe to a primary carrier for interLATA toll service.
- 4.2.7 Provided that <<customer\_short\_name>> purchases unbundled local switching from BellSouth and uses the BellSouth Carrier Identification Code (CIC) for its End Users' Local Preferred Interexchange Carrier (LPIC) or if a BellSouth Local End User selects BellSouth as its LPIC, then the Parties will consider as local any calls originated by a <<customer\_short\_name>> local End User, or originated by a BellSouth local End User and terminated to a <<customer\_short\_name>> local End User, where such calls originate and terminate in the same LATA, except for those calls originated and terminated through switched access arrangements (i.e., calls that are transported by a Party other than BellSouth). Except as set forth in the BellSouth UNE call flows applicable to UNE-P, for such calls, BellSouth will charge <<customer\_short\_name>> the UNE elements for the BellSouth facilities utilized. Neither Party shall bill the other originating or terminating switched access charges for such calls. Intercarrier compensation for local calls between BellSouth and <<customer\_short\_name>> shall be as described in BellSouth's UNE Local call flows applicable to UNE-P as found in BellSouth's 2 Wire Voice Grade UNE Loop/Port Switched Combination Or The Unbundled Network Element Platform (UNE-P) For (Business, Residential and Line Side PBX Service) Including On/Off Premise Extensions guide located on BellSouth's website at <http://interconnection.bellsouth.com/guides/unedocs/2wireVGrdULPSComb.pdf>.
- 4.2.8 Where <<customer\_short\_name>> purchases unbundled local switching from BellSouth but does not use the BellSouth CIC for its End Users' LPIC, BellSouth will consider as local those direct dialed telephone calls that originate from a <<customer\_short\_name>> End User and terminate within the basic local calling

area or within the extended local calling areas and that are dialed using seven (7) or ten (10) digits as defined and specified in Section A3 of BellSouth's General Subscriber Services Tariffs (GSST). Except as set forth in the BellSouth UNE call flows applicable to UNE-P, for such local calls, BellSouth will charge <<customer\_short\_name>> the UNE elements for the BellSouth facilities utilized. Intercarrier compensation for Local calls between BellSouth and <<customer\_short\_name>> shall be as described in BellSouth's 2 Wire Voice Grade UNE Loop/Port Switched Combination Or The Unbundled Network Element Platform (UNE-P) For (Business, Residential and Line Side PBX Service) Including On/Off Premise Extensions guide located on BellSouth's website at <http://interconnection.bellsouth.com/guides/unedocs/2wireVGrdULPSComb.pdf>.

- 4.2.9 For any calls utilizing Unbundled Local Switching, that originate and terminate through switched access arrangements (i.e., calls that are transported by a party other than BellSouth), BellSouth shall bill <<customer\_short\_name>> the UNE elements for the BellSouth facilities utilized. Each Party may bill the toll provider originating or terminating switched access charges as appropriate.
- 4.2.10 Unbundled Port Features
  - 4.2.10.1 Charges for Unbundled Port are as set forth in Exhibit A of this Attachment, and as specified in such exhibit, consistent with Commission rules and orders, may or may not include individual features.
  - 4.2.10.2 Where applicable and available, non-switch-based services may be ordered with the Unbundled Port at BellSouth's retail rates.
  - 4.2.10.3 Any features of Local Switching that are not currently available but are technically feasible through the switch can be requested through the BFR process as set forth in Attachment 11.
  - 4.2.10.4 BellSouth will provide to <<customer\_short\_name>> selective routing of calls to a requested Operator System platform pursuant to this Attachment. Any other routing requests by <<customer\_short\_name>> will be made pursuant to the BFR Process as set forth in Attachment 11.
- 4.2.11 Remote Call Forwarding
  - 4.2.11.1 As an option, BellSouth shall make available to <<customer\_short\_name>> an unbundled port with Remote Call Forwarding capability (URCF service). URCF service combines the functionality of unbundled local switching, tandem switching and common transport to forward calls from the URCF service telephone number (the number dialed by the calling party) to another telephone number selected by the URCF service subscriber. When ordering URCF service, <<customer\_short\_name>> will ensure that the following conditions are satisfied:

- 4.2.11.1.1 That the End User of the forward-to number (service) agrees to receive calls forwarded using the URCF service (if such End User is different from the URCF service End User);
- 4.2.11.1.2 That the forward-to number (service) is equipped with sufficient capacity to receive the volume of calls that will be generated from the URCF service;
- 4.2.11.1.3 That the URCF service will not be utilized to forward calls to another URCF or similar service; and
- 4.2.11.1.4 That the forward-to number (service) is not a public safety number (e.g. 911, fire or police number).
- 4.2.11.2 In addition to the charge for the URCF service port, BellSouth shall charge <<customer\_short\_name>> the rates set forth in Exhibit A of this Attachment for unbundled local switching, tandem switching, and common transport, including all associated usage incurred for calls from the URCF service telephone number (the number dialed by the calling party) to the forward-to number (service).
- 4.2.12 Provision of Local Switching
  - 4.2.12.1 BellSouth shall perform routine testing (e.g., Mechanized Loop Tests (MLT) and test calls such as 105, 107 and 108 type calls) and fault isolation on a mutually agreed upon schedule.
  - 4.2.12.2 BellSouth shall control congestion points such as those caused by radio station call-ins and network routing abnormalities. When necessary, all traffic shall be restricted in a non-discriminatory manner.
  - 4.2.12.3 BellSouth shall perform manual call trace and permit customer originated call trace. BellSouth shall provide Switching Service Point (SSP) capabilities and signaling software to interconnect the signaling links destined to the Signaling Transfer Point Switch (STPS). These capabilities shall adhere to the technical specifications set forth in the applicable industry standard technical references.
  - 4.2.12.4 BellSouth shall provide interfaces to adjuncts through Telcordia standard interfaces. These adjuncts can include, but are not limited to, the Service Circuit Node and Automatic Call Distributors. BellSouth shall offer to <<customer\_short\_name>> all Advanced Intelligent Network (AIN) triggers in connection with its SMS/SCE offering.
  - 4.2.12.5 BellSouth shall provide access to SS7 Signaling Network or Multi-Frequency trunking if requested by <<customer\_short\_name>>.
- 4.2.13 Local Switching Interfaces.

- 4.2.13.1 <<customer\_short\_name>> shall order ports and associated interfaces compatible with the services it wishes to provide as listed in Exhibit A of this Attachment. BellSouth shall provide the following local switching interfaces:
  - 4.2.13.1.1 Standard Tip/Ring interface including loopstart or groundstart, on-hook signaling (e.g., for calling number, calling name and message waiting lamp);
  - 4.2.13.1.2 Coin phone signaling;
  - 4.2.13.1.3 Basic Rate Interface ISDN adhering to appropriate Telcordia Technical Requirements;
  - 4.2.13.1.4 Two-wire analog interface to PBX;
  - 4.2.13.1.5 Four-wire analog interface to PBX;
  - 4.2.13.1.6 Four-wire DS1 interface to PBX or customer provided equipment (e.g. computers and voice response systems);
  - 4.2.13.1.7 Primary Rate ISDN to PBX adhering to ANSI standards Q.931, Q.932 and appropriate Telcordia Technical Requirements;
  - 4.2.13.1.8 Switched Fractional DS1 with capabilities to configure Nx64 channels (where N = 1 to 24);
  - 4.2.13.1.9 DID signaling; and
  - 4.2.13.1.10 Loops adhering to Telcordia TR-NWT-08 and TR-NWT-303 specifications to interconnect Digital Loop Carriers.
- 4.2.14 All End Users of <<customer\_short\_name>> who have service provisioned via 4-Wire ISDN DS1 Port with E911 Locator Capability shall physically be located in the E911 Tandem Switch service area.
- 4.2.15 <<customer\_short\_name>> shall pass its End User's telephone number to BellSouth over the Primary Interface (PRI) trunk group via ANI or via direct Centralized Automated Message Accounting (CAMA) trunks to the appropriate E911 tandem switch.
- 4.2.16 <<customer\_short\_name>> shall maintain the individual telephone number and the correct corresponding address/location data, including maintaining the End User listed address as the actual physical End User location in the E911 Automatic Location Identification (ALI) Database.
- 4.2.17 <<customer\_short\_name>> will be responsible and liable for any errors resulting from the submission of invalid telephone number and address/location data for the CLEC's End Users.



## 4.2 Tandem Switching

4.3.1 The Tandem Switching capability Network Element is defined as: (i) trunk-connect facilities, which include, but are not limited to, the connection between trunk termination at a cross connect panel and switch trunk card; (ii) the basic switch trunk function of connecting trunks to trunks; and (iii) the functions that are centralized in the Tandem Switches (as distinguished from separate end office switches), including but not limited to call recording, the routing of calls to operator services and signaling conversion features.

4.3.1.1 Where <<customer\_short\_name>> utilizes portions of the BellSouth network in originating or terminating traffic, the Tandem Switching rates are applied in call scenarios where the Tandem Switching Network Element has been utilized. Because switch recordings cannot accurately indicate on a per call basis when the Tandem Switching Network Element has been utilized for an interoffice call originating from a UNE port and terminating to a BellSouth, Independent Company or Facility-Based CLEC office, BellSouth has developed, based upon call studies, a melded rate that takes into account the average percentage of calls that utilize Tandem Switching in these scenarios. BellSouth shall apply the melded Tandem Switching rate for every call in these scenarios. BellSouth shall utilize the melded Tandem Switching Rate until BellSouth has the capability to measure actual Tandem Switch usage in each call scenario specifically mentioned above, at which point the rate for the actual Tandem Switch usage shall apply. The UNE call flows applicable to UNE-P set forth on BellSouth's website at <http://interconnection.bellsouth.com/guides/unedocs/2wireVGrdULPSComb.pdf> illustrate when the full or melded Tandem Switching rates apply for specific scenarios.

## 4.3.2 Technical Requirements

4.3.2.1 Tandem Switching shall have the same capabilities or equivalent capabilities as those described in Telcordia TR-TSY-000540 Issue 2R2, Tandem Supplement, June 1, 1990. The requirements for Tandem Switching include but are not limited to the following:

4.3.2.1.1 Tandem Switching shall provide signaling to establish a tandem connection with no loss of feature functionality;

4.3.2.1.2 Based on the line class codes established by <<customer\_short\_name at the BellSouth end office, Tandem Switching will provide screening and routing as designated by <<customer\_short\_name>>.

4.3.2.1.3 Where applicable, Tandem Switching shall provide AIN triggers supporting AIN features where such routing is not available from the originating end office switch, to the extent such Tandem switch has such capability;

- 4.3.2.1.4 Where applicable, Tandem Switching shall provide access to Toll Free number database;
- 4.3.2.1.5 Tandem Switching shall provide connectivity to Public Safety Answering Point (PSAP)s where 911/E911 solutions are deployed and the tandem is used for 911/E911; and
- 4.3.2.1.6 Where appropriate, Tandem Switching shall provide connectivity for the purpose of routing transit traffic to and from other carriers. Tandem switching shall interconnect, with direct trunks, to all carriers with which BellSouth interconnects.
- 4.3.2.2 Upon reasonable request from <<customer\_short\_name>>\_BellSouth will perform testing and fault isolation on the underlying switch that is providing Tandem Switching. Such testing shall be testing routinely performed by BellSouth. The results and reports of the testing shall be made available to <<customer\_short\_name>> as soon as reasonably practicable.
- 4.3.2.3 BellSouth shall control congestion points and network abnormalities. All traffic will be restricted in a non-discriminatory manner.
- 4.3.2.4 Tandem Switching shall process originating toll free traffic received from <<customer\_short\_name>>'s local switch.
- 4.3.2.5 In support of AIN triggers and features, Tandem Switching shall provide Service Switching Point (SSP) capabilities when these capabilities are not available from the Local Switching Network Element to the extent such Tandem Switch has such capability.
- 4.3.3 BellSouth's Tandem Switching shall preserve CLASS/LASS features and Caller ID, when that information is provided to BellSouth, as traffic is processed.
- 4.4 AIN Selective Carrier Routing for Operator Services, Directory Assistance and Repair Centers
  - 4.4.1 Where BellSouth provides local switching to <<customer\_short\_name>>, BellSouth will provide AIN Selective Carrier Routing (AIN SCR) at the request of <<customer\_short\_name>>. AIN SCR will provide <<customer\_short\_name>> with the capability of routing operator calls, 0+ and 0- and 0+ NPA Local Numbering Plan Area (LNPA), 555-1212 directory assistance, 1+411 directory assistance and 611 repair center calls to pre-selected destinations.
  - 4.4.2 <<customer\_short\_name>> shall order AIN SCR through its Account Team and/or Local Contract Manager. AIN SCR must first be established regionally and then on a per central office basis for each office where AIN SCR will be utilized.

- 4.4.3 AIN SCR is not available in DMS 10 switches.
- 4.4.4 Where AIN SCR is utilized by <<customer\_short\_name>>, the routing of <<customer\_short\_name>>'s End User calls shall be pursuant to information provided by <<customer\_short\_name>> and stored in BellSouth's AIN SCR Service Control Point database. AIN SCR shall utilize a set of Line Class Codes (LCCs) unique to a basic class of service assigned on an "as needed" basis. The same LCCs will be assigned in each central office where AIN SCR is established.
- 4.4.5 <<customer\_short\_name>> shall remit to BellSouth the Regional Service Order nonrecurring charges set forth in Exhibit A of this Attachment. There shall be a nonrecurring End Office Establishment Charge per office due at the addition of each central office where AIN SCR will be utilized. Said nonrecurring charge shall be as set forth in Exhibit A of this Attachment. For each <<customer\_short\_name>> End User activated, there shall be a nonrecurring End User Establishment charge as set forth in Exhibit A of this Attachment. <<customer\_short\_name>> shall pay the AIN SCR Per Query Charge set forth in Exhibit A of this Attachment.
- 4.4.6 This Regional Service Order nonrecurring charge will be non-refundable and will be paid with one half due up-front with the submission of all fully completed required forms including: Regional Selective Carrier Routing (SCR) Order Request-Form A, Central Office AIN SCR SCR Order Request - Form B, AIN SCR Central Office Identification Form - Form C, AIN SCR Routing Options Selection Form - Form D, and Routing Combinations Table - Form E. BellSouth has thirty (30) calendar days to respond to <<customer\_short\_name>>'s fully completed firm order as a Regional Service Order. With the delivery of this firm order response to <<customer\_short\_name>>, BellSouth considers that the delivery schedule of this service commences. The remaining half of the Regional Service Order payment must be paid when one hundred (100) percent of the Central Offices listed on the original order have been turned up for the service.
- 4.4.7 The nonrecurring End Office Establishment Charge will be billed to <<customer\_short\_name>> following BellSouth's normal monthly billing cycle for this type of order.
- 4.4.8 End-User Establishment Orders will not be turned-up until the second payment is received for the Regional Service Order. The nonrecurring End-User Establishment Charges will be billed to <<customer\_short\_name>> following BellSouth's normal monthly billing cycle for this type of order.
- 4.4.9 Additionally, the AIN SCR Per Query Charge will be billed to <<customer\_short\_name>> following the normal billing cycle for per query charges.
- 4.4.10 All other network components needed, for example, unbundled switching, unbundled local transport, etc., will be billed per contracted rates.

- 4.5 Selective Call Routing Using Line Class Codes (SCR-LCC)
- 4.5.1 Where <<customer\_short\_name>> purchases unbundled local switching from BellSouth and utilizes an operator services provider other than BellSouth, BellSouth will route <<customer\_short\_name>>'s End User calls to that provider through Selective Call Routing.
- 4.5.2 Selective Call Routing using Line Class Codes (SCR-LCC) provides the capability for <<customer\_short\_name>> to have its Operator Call Processing/Directory Assistance (OCP/DA) calls routed to BellSouth's OCP/DA platform for BellSouth provided Custom Branded or Unbranded OCP/DA or to its own or an alternate OCP/DA platform for Self-Branded OCP/DA. SCR-LCC is only available if line class code capacity is available in the requested BellSouth end office switches.
- 4.5.3 Custom Branding for Directory Assistance (DA) is not available for certain classes of service, including but not limited to Hotel/Motel services, WATS service, and certain PBX services.
- 4.5.4 Where available, <<customer\_short\_name>> specific and unique LCCs are programmed in each BellSouth end office switch where <<customer\_short\_name>> intends to serve End Users with customized OCP/DA branding. The LCCs specifically identify <<customer\_short\_name>>'s End Users so OCP/DA calls can be routed over the appropriate trunk group to the requested OCP/DA platform. Additional LCCs are required in each end office if the end office serves multiple NPAs (i.e., a unique LCC is required per NPA), and/or if the end office switch serves multiple rate areas and <<customer\_short\_name>> intends to provide <<customer\_short\_name>> -branded OCP/DA to its End Users in these multiple rate areas.
- 4.5.5 [Parties Disagree]
- [<<customer\_short\_name>> Version] SCR-LCC supporting Custom Branding and Self Branding require <<customer\_short\_name>> to order dedicated trunking from each BellSouth end office identified by <<customer\_short\_name>>, either to the BellSouth Traffic Operator Position System (TOPS) for Custom Branding or to the <<customer\_short\_name>> Operator Service Provider for Self Branding. Separate trunk groups are required for Operator Services and for DA. Rates for **transport and** trunks are set forth in **Exhibit A to this Attachment**.
- [BellSouth Version] SCR-LCC supporting Custom Branding and Self Branding require <<customer\_short\_name>> to order dedicated trunking from each BellSouth end office identified by <<customer\_short\_name>>, either to the BellSouth Traffic Operator Position System (TOPS) for Custom Branding or to the <<customer\_short\_name>> Operator Service Provider for Self Branding. Separate trunk groups are required for Operator Services and for DA. Rates for trunks are set forth in **applicable BellSouth tariffs**.

- 4.5.6 Unbranding - Unbranded DA and/or OCP calls ride common trunk groups provisioned by BellSouth from those end offices identified by <<customer\_short\_name>> to the BellSouth TOPS.
- 4.5.7 The rates for SCR-LCC are as set forth in Exhibit A of this Attachment. There is a nonrecurring charge for the establishment of each LCC in each BellSouth central office. Furthermore, for Unbranded and Custom Branded OCP/DA provided by BellSouth Operator Services with unbundled ports and unbundled port/loop switch combinations, monthly recurring usage charges shall apply for the UNEs necessary to provide the service, such as end office and tandem switching and common transport. A flat rated end office switching charge shall apply to Self-Branded OCP/DA when used in conjunction with unbundled ports and unbundled port/loop switch combinations.

## **5 Unbundled Network Element Combinations**

- 5.1 BellSouth shall provide unbundled network element combinations in accordance with 47 CFR 51.315.
- 5.1.1 For purposes of this Section, references to “Currently Combined” Network Elements shall mean that the particular Network Elements requested by <<customer\_short\_name>> are in fact already combined by BellSouth in the BellSouth network. References to “Ordinarily Combined” Network Elements shall mean that the particular Network Elements requested by <<customer\_short\_name>> are not already combined by BellSouth in the location requested by <<customer\_short\_name>> but are elements that are typically combined in BellSouth’s network. References to “Not Typically Combined” Network Elements shall mean that the particular Network Elements requested by <<customer\_short\_name>> are not elements that BellSouth combines for its use in its network.
- 5.1.2 Upon request, BellSouth shall perform the functions necessary to combine unbundled Network Elements in any manner, even if those elements are not ordinarily combined in BellSouth’s network, provided that such combination is technically feasible and will not undermine the ability of other carriers to obtain access to unbundled Network Elements or to interconnect with BellSouth’s network.
- 5.2 Enhanced Extended Links (EELs)
- 5.2.1 EELs are combinations of unbundled Loops and unbundled Dedicated Transport, together with any facilities, equipment, or functions necessary to combine those Network Elements. BellSouth shall provide <<customer\_short\_name>> with EELs where the underlying UNE or UNEs are available and in all instances where the requesting carrier meets the FCC’s eligibility requirements, if applicable.
- 5.2.2 EELs include, but are not limited to the following combinations:

- 5.2.2.1 DS1 Interoffice Channel + DS1 Channelization + 2-wire VG Local Loop
- 5.2.2.2 DS1 Interoffice Channel + DS1 Channelization + 4-wire VG Local Loop
- 5.2.2.3 DS1 Interoffice Channel + DS1 Channelization + 2-wire ISDN Local Loop
- 5.2.2.4 DS1 Interoffice Channel + DS1 Channelization + 4-wire 56 kbps Local Loop
- 5.2.2.5 DS1 Interoffice Channel + DS1 Channelization + 4-wire 64 kbps Local Loop
- 5.2.2.6 DS1 Interoffice Channel + DS1 Local Loop
- 5.2.2.7 DS3 Interoffice Channel + DS3 Local Loop
- 5.2.2.8 STS-1 Interoffice Channel + STS-1 Local Loop
- 5.2.2.9 DS3 Interoffice Channel + DS3 Channelization + DS1 Local Loop
- 5.2.2.10 STS-1 Interoffice Channel + DS3 Channelization + DS1 Local Loop
- 5.2.2.11 2-wire VG Interoffice Channel + 2-wire VG Local Loop
- 5.2.2.12 4-wire VG Interoffice Channel + 4-wire VG Local Loop
- 5.2.2.13 4-wire 56 kbps Interoffice Channel + 4-wire 56 kbps Local Loop
- 5.2.2.14 4-wire 64 kbps Interoffice Channel + 4-wire 64 kbps Local Loop
- 5.2.2.15 Commingled loop and transport facilities at the DS1 and/or DS3 level
- 5.2.3 High-capacity EELs are combinations of loop and transport UNEs or commingled loop and transport facilities at the DS1 and/or DS3 level as described in FCC 47 C.F.R. 51.318(b). High-capacity EELs must comply with the service eligibility requirements set forth in Section 5.2.5 below.

5.2.4 [Parties Disagree]

[<<customer\_short\_name>> Version] By placing an order for a high-capacity EEL, <<customer\_short\_name>> thereby certifies that the high-capacity EEL service eligibility criteria set forth herein are met for access to a converted high-capacity EEL, a new high-capacity EEL, or **the UNE portion** of a high-capacity commingled EEL. BellSouth may not deny **or delay** <<customer\_short\_name>>'s request for a high-capacity EEL based upon eligibility criteria. **However, BellSouth may notify <<customer\_short\_name>> when it detects an order that it does not believe complies with the eligibility criteria and <<customer\_short\_name>> shall have the option of modifying or canceling such order.**

**[BellSouth Version]** By placing an order for a high-capacity EEL, <<customer\_short\_name>> thereby certifies that the high-capacity EEL service eligibility criteria set forth herein are met for access to a converted high-capacity EEL, a new high-capacity EEL, or **part** of a high-capacity commingled EEL **as a UNE**. BellSouth may not deny, **except as set forth in Section 5.2.6 below**, <<customer\_short\_name>>'s request for a high-capacity EEL based upon eligibility criteria, **but shall have the right to clarify the order back to <<customer\_short\_name>> rather than processing the order should the BellSouth representative identify that a service eligibility criteria has been violated such as <<customer\_short\_name>> not having a collocation arrangement in the central office for which the order has been requested.**

## 5.2.5 Service Eligibility Criteria

5.2.5.1 By placing an order for a high-capacity EEL, <<customer\_short\_name>> certifies that all of the following service eligibility criteria are met for each high-capacity EEL:

5.2.5.1.1 <<customer\_short\_name>> has received state certification to provide local voice service in the area being served or, in the absence of a state certification requirement, has complied with registration, tariffing, filing fee, or other regulatory requirements applicable to the provision of local voice service in that area;

5.2.5.2 For each combined circuit, including each DS1 circuit, each DS1 EEL, and each DS1-equivalent circuit on a DS3 EEL:

5.2.5.2.1 **[Parties Disagree]**

**[<<customer\_short\_name>> Version]** 1) Each circuit to be provided to each **customer** will be assigned a local number prior to the provision of service over that circuit;

**[BellSouth Version]** 1) Each circuit to be provided to each **End User** will be assigned a local number prior to the provision of service over that circuit;

5.2.5.2.2 2) Each DS1-equivalent circuit on a DS3 EEL must have its own local number assignment, so that each DS3 must have at least twenty-eight (28) local voice numbers assigned to it;

5.2.5.2.3 **[Parties Disagree]**

**[<<customer\_short\_name>> Version]** 3) Each circuit to be provided to each **customer** will have 911 or E911 capability prior to provision of service over that circuit;

[BellSouth Version] 3) Each circuit to be provided to each **End User** will have 911 or E911 capability prior to provision of service over that circuit;

5.2.5.2.4 [Parties Disagree]

[<<customer\_short\_name>> Version] 4) Each circuit to be provided to each **customer** will terminate in a collocation arrangement that meets the requirements of FCC 47 C.F.R. 51.318(c);

[BellSouth Version] 4) Each circuit to be provided to each **End User** will terminate in a collocation arrangement that meets the requirements of FCC 47 C.F.R. 51.318(c);

5.2.5.2.5 [Parties Disagree]

[<<customer\_short\_name>> Version] 5) Each circuit to be provided to each **customer** will be served by an interconnection trunk in the same LATA as the customer premises served by the EEL over which <<customer\_short\_name>> will transmit the calling party's number in connection with calls exchanged over the trunk;

[BellSouth Version] 5) Each circuit to be provided to each **End User** will be served by an interconnection trunk in the same LATA as the customer premises served by the EEL over which <<customer\_short\_name>> will transmit the calling party's number in connection with calls exchanged over the trunk;

5.2.5.2.6 6) For each twenty-four (24) DS1 EELs or other facilities having equivalent capacity, <<customer\_short\_name>> will have at least one (1) active DS1 local service interconnection trunk within the LATA over which <<customer\_short\_name>> will transmit the calling party's number in connection with calls exchanged over the trunk;

5.2.5.2.7 [Parties Disagree]

[<<customer\_short\_name>> Version] 7) Each circuit to be provided to each **customer** will be served by a switch capable of switching local voice traffic.

[BellSouth Version] 7) Each circuit to be provided to each **End User** will be served by a switch capable of switching local voice traffic.

5.2.6 [Parties Disagree]

[<<customer\_short\_name>> Version] BellSouth may, **no more frequently than** on an annual basis, **and only based upon cause, conduct a limited audit of** <<customer\_short\_name>>'s records in order to verify compliance with the **high capacity EEL** eligibility criteria.



[BellSouth Version] BellSouth may, on an annual basis, audit in order to verify compliance with the qualifying service eligibility criteria. **The audit shall be conducted by an independent auditor, and the auditor must perform its evaluation in accordance with the standards established by the American Institute for Certified Public Accountants (AICPA). The auditor will perform an “examination engagement” and issue an opinion regarding <<customer\_short\_name>>’s compliance with the qualifying service eligibility criteria. The independent auditor’s report will conclude whether <<customer\_short\_name>> has complied in all material respects with the applicable service eligibility criteria. Consistent with standard auditing practices, such audits require compliance testing designed by the independent auditor, which typically include an examination of a sample selected in accordance with the independent auditor’s judgment.**

5.2.6.1 [Parties Disagree]

[<<customer\_short\_name>> Version] **To invoke its limited right to audit, BellSouth will send a Notice of Audit to <<customer\_short\_name>>, identifying the particular circuits for which BellSouth alleges non-compliance and the cause upon which BellSouth rests its allegations. The Notice of Audit shall also include all supporting documentation upon which BellSouth establishes the cause that forms the basis of BellSouth’s allegations of noncompliance. Such Notice of Audit will be delivered to <<customer\_short\_name>> with all supporting documentation no less than thirty (30) calendar days prior to the date upon which BellSouth seeks to commence an audit.**

[BellSouth Version] **No Section.**

5.2.6.2 [Parties Disagree]

[<<customer\_short\_name>> Version] **The audit shall be conducted by a third party independent auditor mutually agreed-upon by the Parties and retained and paid for by BellSouth. The audit shall commence at a mutually agreeable location (or locations) no sooner than thirty (30) calendar days after the parties have reached agreement on the auditor.**

[BellSouth Version] **No Section.**

5.2.6.2.1 [Parties Disagree]

[<<customer\_short\_name>> Version] **The audit must be performed in accordance with the standards established by the American Institute for Certified Public Accountants (AICPA) which will require the auditor to perform an “examination engagement” and issue an opinion regarding <<customer\_short\_name>>’s compliance with the high capacity EEL eligibility criteria. AICPA standards and other requirements related to determining the independence of an auditor shall govern the audit of requesting carrier compliance. The concept of materiality**

governs this audit; the independent auditor's report will conclude whether or the extent to which <<customer\_short\_name>> complied in all material respects with the applicable service eligibility criteria. Consistent with standard auditing practices, such audits require compliance testing designed by the independent auditor, which typically include an examination of a sample selected in accordance with the independent auditor's judgment.

**[BellSouth Version] No Section.**

5.2.6.2.2 To the extent the independent auditor's report concludes that <<customer\_short\_name>> failed to comply with the high capacity EEL service eligibility criteria, <<customer\_short\_name>> must true-up any difference in payments, convert all noncompliant circuits to the appropriate service, and make the correct payments on a going-forward basis.

5.2.6.2.3 **[Parties Disagree]**

**[<<customer\_short\_name>> Version]** In the event the auditor's report concludes that <<customer\_short\_name>> **did not** comply in all **material** respects with the service eligibility criteria, <<customer\_short\_name>> shall reimburse BellSouth for the cost of the independent auditor. Similarly, to the extent the independent auditor's report concludes that <<customer\_short\_name>> did comply in all material respects with the service eligibility criteria, BellSouth will reimburse <<customer\_short\_name>> for its reasonable and demonstrable costs associated with the audit, including, among other things, staff time. The Parties shall provide such reimbursement within thirty (30) calendar days of receipt from <<customer\_short\_name>> of a statement of such costs.

**[BellSouth Version]** To the extent the **independent** auditor's report concludes that <<customer\_short\_name>> **failed to** comply with the service eligibility criteria, <<customer\_short\_name>> shall reimburse BellSouth for the cost of the independent auditor. Similarly, to the extent the independent auditor's report concludes that <<customer\_short\_name>> did comply in all material respects with the service eligibility criteria, BellSouth will reimburse <<customer\_short\_name>> for its reasonable and demonstrable costs associated with the audit, including, among other things, staff time. The Parties shall provide such reimbursement within thirty (30) calendar days of receipt from <<customer\_short\_name>> of a statement of such costs.

5.2.6.2.4 <<customer\_short\_name>> will maintain appropriate documentation to support its certifications.

### **5.3 UNE Port/Loop Combinations**

5.3.1 Combinations of port and loop unbundled Network Elements along with switching and transport unbundled Network Elements provide local exchange service for the origination or termination of calls. Port/loop combinations support the same local calling and feature requirements as described in the Unbundled

Local Switching Section of this Attachment and the ability to presubscribe to a primary carrier for intraLATA toll service and/or to presubscribe to a primary carrier for interLATA toll service.

5.3.2 BellSouth is not required to provide combinations of port and loop Network Elements on an unbundled basis in locations where, pursuant to FCC and Commission rules, BellSouth is not required to provide local circuit switching as set forth in Section 4.2.2 above.

5.3.3 UNE Port/Loop combinations include but are not limited to the following:

5.3.3.1 2-wire voice grade Loop with 2-wire port.

5.3.3.2 2-wire voice grade Loop with 2-wire analog line\_Coin port.

5.3.3.3 2-wire voice grade Loop – business only – with 2-wire\_DID port.

5.3.3.4 2-wire CENTREX port, voice grade Loop with 2-wire voice grade port (CENTREX).

5.3.3.5 2-wire voice grade Loop with 2-wire ISDN digital line side port.

5.3.3.6 2-wire voice Loop with 2-wire voice grade interoffice transport with 2-wire line port

5.3.3.7 4-wire DS1 Loop with 4-wire ISDN DS1 digital trunk port.

5.3.3.8 4-wire DS1 Loop with 4-wire DDITS trunk port.

5.3.3.9 4-wire DS1 Loop with channelization with port.

5.3.4 BellSouth shall make 911 updates in the BellSouth 911 database for <<customer\_short\_name>>'s UNE port/Loop combinations. BellSouth will not bill <<customer\_short\_name>> for 911 surcharges. <<customer\_short\_name>> is responsible for paying all 911 surcharges to the applicable governmental agency.

5.4 Rates

5.4.1 The rates for the Currently Combined Network Elements specifically set forth in Exhibit A of this Attachment shall be the rates associated with such combinations. Where a Currently Combined combination is not specifically set forth in Exhibit A of this Attachment, the rate for such Currently Combined combination of Network Elements shall be the sum of the recurring rates for those individual Network Elements in addition to the applicable non-recurring switch-as-is charge set forth in Exhibit A of this Attachment.

5.4.2 The rates for the Ordinarily Combined Network Elements specifically set forth in Exhibit A of this Attachment shall be the non-recurring and recurring charges for

those combinations. Where an Ordinarily Combined combination is not specifically set forth in Exhibit A of this Attachment, the rate for such Ordinarily Combined combination of Network Elements shall be the sum of the recurring and non-recurring rates for those individual Network Elements as set forth in Exhibit A of this Attachment.

5.4.3 BellSouth shall provide other Currently Combined and Ordinarily Combined and Not Typically Combined UNE Combinations to <<customer\_short\_name>> in addition to those specifically referenced in this Section 5 above, where available. To the extent <<customer\_short\_name>> requests a combination for which BellSouth does not have rates and methods and procedures in place to provide such combination, rates and/or methods and procedures for such combination will be developed pursuant to the BFR process.

## 6 **Transport, Channelization and Dark Fiber**

6.1 Transport

6.1.1 [Parties Disagree]

[<<customer\_short\_name>> Version] **BellSouth shall offer access to unbundled Dedicated Transport in accordance with 47 CFR 319(e).** Dedicated Transport is defined as BellSouth's interoffice transmission facilities, dedicated to a particular customer or carrier that <<customer\_short\_name>> uses for transmission between wire centers or switches owned by BellSouth **and to the extent that BellSouth has local switching equipment, as defined by the FCC's rules, "reverse collocated" in a non-incumbent LEC premises, the transmission path from this point back to the BellSouth wire center shall be unbundled as transport between incumbent LEC switches or wire centers to the extent specified in part 51 of the FCC's rules** within the same LATA.

[BellSouth Version] Dedicated Transport is defined as BellSouth's interoffice transmission facilities, dedicated to a particular customer or carrier that <<customer\_short\_name>> uses for transmission between wire centers or switches owned by BellSouth and within the same LATA.

6.1.1.1 [Parties Disagree]

[<<customer\_short\_name>> Version] Dark Fiber Transport is as defined in 47 CFR 51.319(e).

[BellSouth Version] Dark Fiber Transport is unactivated optical interoffice transmission facilities between wire centers or switches owned by BellSouth.

6.1.1.2 Common (Shared) Transport is as defined in 47 C.F.R. 51.319(d)(4)(i)(C). Where BellSouth UNEs are connected by intraoffice wiring, such wiring is provided as part of the UNE and is not Common (Shared) Transport.

- 6.1.1.3 BellSouth will only provide unbundled access to Common (Shared) Transport to the extent BellSouth is required to provide and is providing unbundled Local Circuit Switching to <<customer\_short\_name>>.
- 6.1.2 BellSouth shall:
  - 6.1.2.1 Provide <<customer\_short\_name>> exclusive use of Dedicated Transport to a particular customer or carrier, or shared use of the features, functions, and capabilities of interoffice transmission facilities shared by more than one customer or carrier;
  - 6.1.2.2 Provide all technically feasible features, functions, and capabilities of the transport facility;
  - 6.1.2.3 Permit, to the extent technically feasible, <<customer\_short\_name>> to connect such interoffice facilities to equipment designated by <<customer\_short\_name>>, including but not limited to, <<customer\_short\_name>>'s collocated facilities; and
  - 6.1.2.4 Permit, to the extent technically feasible and on a nondiscriminatory basis, <<customer\_short\_name>> to obtain the functionality provided by BellSouth's digital cross-connect systems.
- 6.1.3 Technical Requirements of Common (Shared) Transport
  - 6.1.3.1 Common (Shared) Transport provided on DS1, DS3, and STS-1 circuits shall at a minimum meet the performance, availability, jitter, and delay requirements specified for Central Office to Central Office (CO to CO) connections in the applicable industry standards.
  - 6.1.3.2 BellSouth shall be responsible for the engineering, provisioning, and maintenance of the underlying equipment and facilities that are used to provide Common (Shared) Transport.
  - 6.1.3.3 At a minimum, Common (Shared) Transport shall meet all of the requirements set forth in the applicable industry standards.
- 6.2 Dedicated Transport
  - 6.2.1 BellSouth shall offer Dedicated Transport in each of the following ways:
    - 6.2.1.1 As capacity on a shared facility.
    - 6.2.1.2 As a circuit (e.g., DS0, DS1, DS3) dedicated to <<customer\_short\_name>>.
  - 6.2.2 Dedicated Transport may be provided over facilities such as optical fiber, copper twisted pair, and coaxial cable, and shall include transmission equipment such as line terminating equipment, amplifiers, and regenerators.

- 6.2.3 <<customer\_short\_name>> may obtain a maximum of twelve (12) unbundled dedicated DS3 circuits, or their equivalent, for any single route at the UNE rates set forth in Exhibit A of this Attachment for which dedicated DS3 transport is available as unbundled transport. Additional capacity may be purchased pursuant to the rates, terms and conditions as set forth in the applicable tariff. A route is defined as a transmission path between one of BellSouth's wire centers or switches and another of BellSouth's wire centers or switches. A route between two (2) points may pass through one or more intermediate wire centers or switches. Transmission paths between identical end points are the same "route", irrespective of whether they pass through the same intermediate wire centers or switches, if any.
- 6.2.4 Any request to re-terminate one end of a circuit will require the issuance of new service and disconnection of the existing service and the applicable charges in Exhibit A of this Attachment shall apply, and the re-terminated circuit shall be considered a new circuit as of the installation date.
- 6.2.5 Technical Requirements
- 6.2.5.1 The entire designated transmission service (e.g., DS0, DS1, DS3) shall be dedicated to <<customer\_short\_name>> designated traffic.
- 6.2.5.2 For DS1 or DS3 circuits, Dedicated Transport shall at a minimum meet the performance, availability, jitter, and delay requirements specified for Customer Interface to Central Office (CI to CO) connections in the applicable industry standards.
- 6.2.5.3 BellSouth shall offer the following interface transmission rates for Dedicated Transport:
- 6.2.5.3.1 DS0 Equivalent;
- 6.2.5.3.2 DS1;
- 6.2.5.3.3 DS3; and
- 6.2.5.3.4 SDH (Synchronous Digital Hierarchy) Standard interface rates are in accordance with International Telecommunications Union (ITU) Recommendation G.707 and Plesiochronous Digital Hierarchy (PDH) rates per ITU Recommendation G.704.
- 6.2.5.4 BellSouth shall design Dedicated Transport according to its network infrastructure. <<customer\_short\_name>> shall specify the termination points for Dedicated Transport.
- 6.2.5.5 At a minimum, Dedicated Transport shall meet each of the requirements set forth in the applicable industry technical references.
- 6.2.5.6 BellSouth Technical References:

- 6.2.5.6.1 TR-TSY-000191 Alarm Indication Signals Requirements and Objectives, Issue 1, May 1986.
- 6.2.5.6.2 TR 73501 LightGate®Service Interface and Performance Specifications, Issue D, June 1995.
- 6.2.5.6.3 TR 73525 MegaLink®Service, MegaLink Channel Service and MegaLink Plus Service Interface and Performance Specifications, Issue C, May 1996.

### 6.3 Unbundled Channelization (Multiplexing)

6.3.1 Unbundled Channelization (UC) provides the optional multiplexing capability that will allow a DS1 (1.544 Mbps) or DS3 (44.736 Mbps) or STS-1 (51.84 Mbps) UNE or collocation cross connect to be multiplexed or channelized at a BellSouth central office. Channelization can be accomplished through the use of a multiplexer or a digital cross connect system at the discretion of BellSouth. Once UC has been installed, <<customer\_short\_name>> may request channel activation on an as needed basis and BellSouth shall connect the requested facilities via Central Office Channel Interfaces (COCI). The COCI must be compatible with the lower capacity facility and ordered with the lower capacity facility. This service is available as defined in NECA 4. Channelization may be incorporated within dedicated transport or ordered as a stand-alone capability, which requires either the high or low speed side to be connected to collocation.

6.3.2 BellSouth shall make available the following channelization systems and interfaces:

6.3.2.1 DS1 Channelization System: channelizes a DS1 signal into a maximum of twenty-four (24) DS0s. The following Central Office Channel Interfaces (COCI) are available: Voice Grade, Digital Data and ISDN.

6.3.2.2 DS3 Channelization System: channelizes a DS3 signal into a maximum of twenty-eight (28) DS1s. A DS1 COCI is available with this system.

6.3.2.3 STS-1 Channelization System: channelizes a STS-1 signal into a maximum of twenty-eight (28) DS1s. A DS1 COCI is available with this system.

6.3.2.4 AMI and B8ZS line coding with either Super Frame (SF) and Extended Super Frame (ESF) framing formats will be supported as an optional feature on DS1 facilities.

### 6.3.3 Technical Requirements

6.3.3.1 In order to assure proper operation with BellSouth provided central office multiplexing functionality, <<customer\_short\_name>>'s channelization equipment must adhere strictly to form and protocol standards. <<customer\_short\_name>> must also adhere to such applicable industry

standards for the multiplex channel bank, for voice frequency encoding, for various signaling schemes, and for sub rate digital access.

6.3.3.2 TR 73501 LightGate<sup>®</sup> Service Interface and Performance Specifications, Issue D, June 1995

6.4 Dark Fiber Transport

6.4.1 BellSouth shall make Dark Fiber Transport available in accordance with FCC Rule 51.319 (e)(3). Dark Fiber Transport consists of unactivated optical interoffice transmission facilities existing in aerial or underground structure.

6.4.2 [Parties Disagree]

[<<customer\_short\_name Version] <<customer\_short\_name>> may splice and test Dark Fiber Transport obtained from BellSouth, at any technically feasible point, using CLEC or CLEC designated personnel. BellSouth shall provide appropriate interfaces to allow splicing and testing of Dark Fiber.

[BellSouth Version] <<customer\_short\_name>> may test Dark Fiber Transport obtained from BellSouth using CLEC or CLEC designated personnel. BellSouth shall provide appropriate interfaces to allow Dark Fiber.

6.4.3 Requirements

6.4.3.1 BellSouth shall make available in a reasonable and nondiscriminatory manner Dark Fiber Transport where it exists in BellSouth's network and where, as a result of future building or deployment, it becomes available. Dark Fiber Transport will not be deemed available if (1) it is used by BellSouth for maintenance and repair purposes, (2) it is designated for use pursuant to a firm order placed by another customer, (3) it is restricted for use by all carriers, including BellSouth, because of transmission problems or because it is scheduled for removal due to documented changes to roads and infrastructure, or (4) BellSouth has plans to use the fiber within a two-year planning period. BellSouth is not required to place fibers for Dark Fiber Transport if there are none available.

6.4.3.2 <<customer\_short\_name>> may test the quality of the Dark Fiber Transport to determine its usability and performance specifications.

6.4.3.3 BellSouth shall use its best efforts to provide to <<customer\_short\_name>> information regarding the location, availability and performance of Dark Fiber Transport within ten (10) business days after receiving a request from <<customer\_short\_name>>. Within such time period, BellSouth shall send written confirmation of availability of the Dark Fiber Transport.

6.4.3.4 If the requested Dark Fiber Transport is available, BellSouth shall use its commercially reasonable efforts to provision the Dark Fiber Transport to <<customer\_short\_name>> within twenty (20) business days after



<<customer\_short\_name>> submits a valid, error free LSR. Provisioning includes identification of appropriate connection points (e.g., LGX) to enable <<customer\_short\_name>> to connect <<customer\_short\_name>> provided transmission media (e.g., optical fiber) or equipment to the Dark Fiber Transport.

- 6.4.3.5 If requested dark fiber has any lightwave repeater equipment interspliced to it, BellSouth will remove such equipment at <<customer\_short\_name>>'s request subject to time and materials charges.
- 6.4.4 If deployed in BellSouth's network, on a case by case basis, BellSouth may provide wave division multiplexer ("WDM") applications at rates to be negotiated by the Parties. For WDM applications, BellSouth shall provide to <<customer\_short\_name>> an interface to an existing WDM device or allow <<customer\_short\_name>> to install its own WDM device (where sufficient system loss margins exist or where <<customer\_short\_name>> provides the necessary loss compensation) to multiplex the traffic at wavelengths. This applies to both the transmit and the receive ends of the Dark Fiber.

## 7 Service Control Points (SCPs)/Databases

- 7.1 911 and E911 databases. BellSouth shall provide <<customer\_short\_name>> with nondiscriminatory access to 911 and E911 databases on an unbundled basis, in accordance with 47 CFR 319(f).
- 7.2 [Parties Disagree]

[<<customer\_short\_name>> Version] Call Related Databases are the databases other than OSS, that are used in signaling networks for billing and collection, or the transmission, routing or other provision of a telecommunications service. BellSouth shall only provide unbundled access to BellSouth Switched Access (SWA) 8XX Toll Free Dialing Ten Digit Screening Service, Line Information Database (LIDB), Signaling, Signaling Link Transport, Signaling Transfer Points, SS7 AIN Access, Service Control Point/Databases, Local Number Portability Databases, SS7 Network Interconnection, and Calling Name (CNAM) Database Service at the prices set forth herein where BellSouth is required to provide and is providing unbundled access to local circuit switching to <<customer\_short\_name>>. **SS7 Network Interconnection and Signaling Link Transport shall be provided at the TELRIC-compliant, Commission approved rates set forth in Exhibit A of Attachment 3, regardless of whether BellSouth is required to provide and is providing unbundled access to local circuit switching to <<customer\_short\_name>>.**

[BellSouth Version] Call Related Databases are the databases **set forth in this Attachment**, other than OSS, that are used in signaling networks for billing and collection, or the transmission, routing or other provision of a telecommunications service. **Notwithstanding anything to the contrary herein**, BellSouth shall only provide unbundled access to BellSouth Switched Access (SWA) 8XX Toll Free

Dialing Ten Digit Screening Service, Line Information Database (LIDB), Signaling, Signaling Link Transport, Signaling Transfer Points, SS7 AIN Access, Service Control Point\Databases, Local Number Portability Databases, SS7 Network Interconnection, and Calling Name (CNAM) Database Service at the prices set forth herein where BellSouth is required to provide and is providing unbundled access to local circuit switching to <<customer\_short\_name>>.

7.3 [Parties Disagree]

[<<customer\_short\_name>> Version] To the extent unbundled local circuit switching is converted to market based switching pursuant to Section 4.2.2 above, BellSouth may, at its discretion, provide access to BellSouth Switched Access (SWA) 8XX Toll Free Dialing Ten Digit Screening Service, LIDB, Signaling, Signaling Transfer Points, SS7 AIN Access, Service Control Point\Databases, Local Number Portability Databases, Calling Name (CNAM) at market based rates pursuant to a separate agreement or tariff.

[BellSouth Version] To the extent unbundled local circuit switching is converted to market based switching pursuant to Section 4.2.2 above, BellSouth may, at its discretion, provide access to BellSouth Switched Access (SWA) 8XX Toll Free Dialing Ten Digit Screening Service, LIDB, Signaling, **Signaling Link Transport**, Signaling Transfer Points, SS7 AIN Access, Service Control Point\Databases, Local Number Portability Databases, **SS7 Network Interconnection**, Calling Name (CNAM) at market based rates pursuant to a separate agreement or tariff.

7.4 [Parties Disagree]

[<<customer\_short\_name>> Version] The Parties agree that they will perform CNAM queries and pass such information on all calls exchanged between the Parties, regardless of whether that would require BellSouth to query a third party database provider.

[BellSouth Version] Nothing in this Agreement will be construed to require BellSouth to query a third party database. Should BellSouth query a third party database then it will be performed subject to a separate agreement. If BellSouth terminates an agreement with a third party database provider, then BellSouth will provide a carrier notification letter to the CLECs.

7.5 Service management systems are defined as computer databases or systems not part of the public switched network that interconnect to the service control point and send to the service control point information and call processing instructions needed for a network switch to process and complete a telephone call, and provide a telecommunications carrier with the capability of entering and storing data regarding the processing and completing of a telephone call. Where <<customer\_short\_name>> purchases unbundled local circuit switching BellSouth, BellSouth shall allow <<customer\_short\_name>> carrier to use

BellSouth's service management systems by providing <<customer\_short\_name>> with the information necessary to enter correctly, or format for entry, the information relevant for input into the BellSouth's service management system, including access to design, create, test, and deploy advanced intelligent network-based services at the service management system, through a service creation environment, that BellSouth provides to itself.

## **8 Toll Free Number Database / BellSouth Switched Access (SWA) 8XX Toll Free Dialing Ten Digit Screening Service**

- 8.1 The BellSouth SWA 8XX Toll Free Dialing Ten Digit Screening Service database (8XX SCP Database) is a SCP that contains customer record information and the functionality to provide call-handling instructions for 8XX calls. The 8XX SCP IN software stores data downloaded from the national SMS/8XX database and provides the routing instructions in response to queries from the SSP or tandem. The BellSouth SWA 8XX Toll Free Dialing Ten Digit Screening Service (8XX TFD Service) utilizes the 8XX SCP Database to provide identification and routing of the 8XX calls, based on the ten digits dialed. At <<customer\_short\_name>>'s option, 8XX TFD Service is provided with or without POTS number delivery, dialing number delivery, and other optional complex features as selected by <<customer\_short\_name>>.
- 8.2 The 8XX SCP Database is designated to receive and respond to queries using the ANSI Specification of Signaling System Seven (SS7) protocol.
- 8.3 BellSouth provides four (4) options of this service, two (2) that provide POTS number delivery and two (2) that provide Toll Free Dialing Number Delivery.

## **9 Line Information Database**

- 9.1 LIDB is a transaction-oriented database accessible through Common Channel Signaling (CCS) networks. For access to LIDB, <<customer\_short\_name>> must purchase appropriate signaling links pursuant to Section 10 below. LIDB contains records associated with End User Line Numbers and Special Billing Numbers. LIDB accepts queries from other Network Elements and provides appropriate responses. The query originator need not be the owner of LIDB data. LIDB queries include functions such as screening billed numbers that provides the ability to accept Collect or Third Number Billing calls and validation of Telephone Line Number based non-proprietary calling cards. The interface for the LIDB functionality is the interface between BellSouth's CCS network and other CCS networks. LIDB also interfaces to administrative systems.
- 9.2 Technical Requirements
- 9.2.1 BellSouth will offer to <<customer\_short\_name>> any additional capabilities that are developed for LIDB during the life of this Agreement.

- 9.2.2 BellSouth shall process <<customer\_short\_name>>'s customer records in LIDB at least at parity with BellSouth customer records, with respect to other LIDB functions. BellSouth shall indicate to <<customer\_short\_name>> what additional functions (if any) are performed by LIDB in the BellSouth network.
- 9.2.3 Within two (2) weeks after a request by <<customer\_short\_name>>, BellSouth shall provide <<customer\_short\_name>> with a list of the customer data items, which <<customer\_short\_name>> would have to provide in order to support each required LIDB function. The list shall indicate which data items are essential to LIDB function and which are required only to support certain services. For each data item, the list shall show the data formats, the acceptable values of the data item and the meaning of those values.
- 9.2.4 BellSouth shall provide LIDB systems for which operating deficiencies that would result in calls being blocked shall not exceed thirty (30) minutes per year.
- 9.2.5 BellSouth shall provide LIDB systems for which operating deficiencies that would not result in calls being blocked shall not exceed twelve (12) hours per year.
- 9.2.6 BellSouth shall provide LIDB systems for which the LIDB function shall be in overload no more than twelve (12) hours per year.
- 9.2.7 All additions, updates and deletions of <<customer\_short\_name>> data to the LIDB shall be solely at the direction of <<customer\_short\_name>>. Such direction from <<customer\_short\_name>> will not be required where the addition, update or deletion is necessary to perform standard fraud control measures (e.g., calling card auto-deactivation).
- 9.2.8 BellSouth shall provide priority updates to LIDB for <<customer\_short\_name>> data upon <<customer\_short\_name>>'s request (e.g., to support fraud detection), via password-protected telephone card, facsimile, or electronic mail within one hour of notice from the established BellSouth contact.
- 9.2.9 BellSouth shall provide LIDB systems such that no more than 0.01% of <<customer\_short\_name>> customer records will be missing from LIDB, as measured by <<customer\_short\_name>> audits. BellSouth will audit <<customer\_short\_name>> records in LIDB against Data Base Administration System (DBAS) to identify record mismatches and provide this data to a designated <<customer\_short\_name>> contact person to resolve the status of the records and BellSouth will update system appropriately. BellSouth will refer record of mismatches to <<customer\_short\_name>> within one (1) business day of audit. Once reconciled records are received back from <<customer\_short\_name>>, BellSouth will update LIDB the same business day if less than 500 records are received before 1:00PM Central Time. If more than 500 records are received, BellSouth will contact <<customer\_short\_name>> to negotiate a time frame for the updates, not to exceed three (3) business days.

- 9.2.10 BellSouth shall perform backup and recovery of all of <<customer\_short\_name>>'s data in LIDB including sending to LIDB all changes made since the date of the most recent backup copy, in at least the same time frame BellSouth performs backup and recovery of BellSouth data in LIDB for itself. Currently, BellSouth performs backups of the LIDB for itself on a weekly basis; and when a new software release is scheduled, a backup is performed prior to loading the new release.
- 9.2.11 BellSouth shall provide <<customer\_short\_name>> with LIDB reports of data which are missing or contain errors, as well as any misrouted errors, within a reasonable time period as negotiated between <<customer\_short\_name>> and BellSouth.
- 9.2.12 BellSouth shall prevent any access to or use of <<customer\_short\_name>> data in LIDB by BellSouth personnel that are outside of established administrative and fraud control personnel, or by any other Party that is not authorized by <<customer\_short\_name>> in writing.
- 9.2.13 BellSouth shall provide <<customer\_short\_name>> performance of the LIDB Data Screening function, which allows a LIDB to completely or partially deny specific query originators access to LIDB data owned by specific data owners, for Customer Data that is part of an NPA-NXX or RAO-0/1XX wholly or partially owned by <<customer\_short\_name>> at least at parity with BellSouth Customer Data. BellSouth shall obtain from <<customer\_short\_name>> the screening information associated with LIDB Data Screening of <<customer\_short\_name>> data in accordance with this requirement. BellSouth currently does not have LIDB Data Screening capabilities. When such capability is available, BellSouth shall offer it to <<customer\_short\_name>> under the BFR/NBR process as set forth in Attachment 11.
- 9.2.14 BellSouth shall accept queries to LIDB associated with <<customer\_short\_name>> customer records and shall return responses in accordance with industry standards.
- 9.2.15 BellSouth shall provide mean processing time at the LIDB within 0.50 seconds under normal conditions as defined in industry standards.
- 9.2.16 BellSouth shall provide processing time at the LIDB within 1 second for 99% of all messages under normal conditions as defined in industry standards.
- 9.3 Interface Requirements
- 9.3.1 BellSouth shall offer LIDB in accordance with the requirements of this subsection.
- 9.3.2 The interface to LIDB shall be in accordance with the technical references contained within.

- 9.3.3 The CCS interface to LIDB shall be the standard interface described herein.
- 9.3.4 The LIDB Data Base interpretation of the ANSI-TCAP messages shall comply with the technical reference herein. Global Title Translation (GTT) shall be maintained in the signaling network in order to support signaling network routing to the LIDB.
- 9.3.5 [Parties Disagree]

[<<customer\_short\_name>> Version] No Section.

[BellSouth Version] The application of the LIDB rates contained in Exhibit A of this Attachment will be based on a Percent CLEC LIDB Usage (PCLU) factor. <<customer\_short\_name>> shall provide BellSouth a PCLU. The PCLU will be applied to determine the percentage of total LIDB usage to be billed to the other Party at local rates. <<customer\_short\_name>> shall update its PCLU on the first of January, April, July and October and shall send it to BellSouth to be received no later than thirty (30) calendar days after the first of each such month based on local usage for the past three months ending the last day of December, March, June and September, respectively. Requirements associated with PCLU calculation and reporting shall be as set forth in BellSouth's Jurisdictional Factors Reporting Guide, as it is amended from time to time.

## 10 Signaling

- 10.1 BellSouth shall offer access to signaling and access to BellSouth's signaling databases subject to compatibility testing and at the rates set forth in Exhibit A of this Attachment. BellSouth may provide mediated access to BellSouth signaling systems and databases. Available signaling elements include signaling links, signal transfer points and service control points. Signaling functionality will be available with both A-link and B-link connectivity.
- 10.2 Signaling Link Transport
- 10.2.1 Signaling Link Transport is a set of two (2) or four (4) dedicated 56 kbps transmission paths between <<customer\_short\_name>> designated Signaling Points of Interconnection that provide appropriate physical diversity.
- 10.2.2 Technical Requirements
- 10.2.3 Signaling Link Transport shall consist of full duplex mode 56 kbps transmission paths and shall perform in the following two ways:
- 10.2.3.1 As an "A-link" Signaling Link Transport is a connection between a switch or SCP and a home Signaling Transfer Point switch pair; and

- 10.2.3.2 As a “B-link” Signaling Link Transport is a connection between two Signaling Transfer Point switch pairs in different company networks (e.g., between two Signaling Transfer Point switch pairs for two CLECs).
- 10.2.4 Signaling Link Transport shall consist of two (2) or more signaling link layers as follows:
  - 10.2.4.1 An A-link layer shall consist of two (2) links. There shall be no more than two minutes down time per year for an A-link layer.
  - 10.2.4.2 A B-link layer shall consist of four (4) links. There shall be negligible (less than 2 seconds) down time per year for a B-link layer. A signaling link layer shall satisfy interoffice and intraoffice diversity of facilities and equipment, such that:
    - 10.2.4.2.1 No single failure of facilities or equipment causes the failure of both links in an A-link layer (i.e., the links should be provided on a minimum of two (2) separate physical paths end-to-end); and
    - 10.2.4.2.2 No two (2) concurrent failures of facilities or equipment shall cause the failure of all four (4) links in a B-link layer (i.e., the links should be provided on a minimum of three separate physical paths end-to-end).
- 10.2.5 Interface Requirements
  - 10.2.5.1 There shall be a DS1 (1.544 Mbps) interface at <<customer\_short\_name>>’s designated SPOIs. Each 56 kbps transmission path shall appear as a DS0 channel within the DS1 interface.
- 10.3 Signaling Transfer Points
  - 10.3.1 A STP is a signaling network function that includes all of the capabilities provided by the signaling transfer point switches (STPS) and their associated signaling links that enables the exchange of SS7 messages among and between switching elements, database elements and STPSs.
  - 10.3.2 Technical Requirements
    - 10.3.2.1 STPs shall provide access to BellSouth Local Switching or Tandem Switching and to BellSouth Service Control Points/Databases connected to BellSouth SS7 network. STPs also provide access to third-party local or tandem switching and third-party-provided STPs.
    - 10.3.2.2 The connectivity provided by STPs shall fully support the functions of all other Network Elements connected to the BellSouth SS7 network. This includes the use of the BellSouth SS7 network to convey messages that neither originate nor terminate at a signaling end point directly connected to the BellSouth SS7 network (i.e., transit messages). When the BellSouth SS7 network is used to convey transit messages, there shall be no alteration of the Integrated Services

Digital Network User Part or Transaction Capabilities Application Part (TCAP) user data that constitutes the content of the message.

- 10.3.2.3 If a BellSouth tandem switch routes traffic, based on dialed or translated digits, on SS7 trunks between a <<customer\_short\_name>> local switch and third party local switch, the BellSouth SS7 network shall convey the TCAP messages that are necessary to provide Call Management features (Automatic Callback, Automatic Recall, and Screening List Editing) between <<customer\_short\_name>> local STPs and the STPs that provide connectivity with the third party local switch, even if the third party local switch is not directly connected to BellSouth STPs.
- 10.3.2.4 STPs shall provide all functions of the SCCP necessary for Class 0 (basic connectionless) service as defined in Telcordia ANSI Interconnection Requirements. This includes GTT and SCCP Management procedures, as specified in ANSI T1.112.4. Where the destination signaling point is a <<customer\_short\_name>> or third party local or tandem switching system directly connected to BellSouth SS7 network, BellSouth shall perform final GTT of messages to the destination and SCCP Subsystem Management of the destination. In all other cases, BellSouth shall perform intermediate GTT of messages to a gateway pair of STPs in an SS7 network connected with BellSouth SS7 network and shall not perform SCCP Subsystem Management of the destination. If BellSouth performs final GTT to a <<customer\_short\_name>> database, then <<customer\_short\_name>> agrees to provide BellSouth with the Destination Point Code for <<customer\_short\_name>> database.
- 10.3.2.5 STPs shall provide all functions of the Operations, Maintenance and Administration Part (OMAP) as specified in applicable industry standard technical references, which may include, where available in BellSouth's network, MTP Routing Verification Test (MRVT) and SCCP Routing Verification Test (SRVT).
- 10.3.2.6 Where the destination signaling point is a BellSouth local or tandem switching system or database, or is a <<customer\_short\_name>> or third party local or tandem switching system directly connected to the BellSouth SS7 network, STPs shall perform MRVT and SRVT to the destination signaling point. In all other cases, STPs shall perform MRVT and SRVT to a gateway pair of STPs in an SS7 network connected with the BellSouth SS7 network. This requirement may be superseded by the specifications for Internetwork MRVT and SRVT when these become approved ANSI standards and available capabilities of BellSouth STPs.
- 10.3.2.7 <<customer\_short\_name>> may choose to route SS7 signaling information (e.g., ISUP, TSAP) from <<customer\_short\_name>>'s signaling network to another LECs or CMRS provider's signaling network via BellSouth's signaling network for the purpose of exchanging call processing/network information between <<customer\_short\_name>> and the other LEC's or CMRS provider's network, whether or not BellSouth has a trunk to the terminating switching, provided that,



where BellSouth does not have such a trunk, <<customer\_short\_name>> furnishes BellSouth with:

- 10.3.2.7.1 the destination point codes (“DPCs”) of all the LEC or CMRS provider switches to which it wishes to send transit signaling;
- 10.3.2.7.2 the identify of the STPs in BellSouth’s network in which each DPC will be translated; and
- 10.3.2.7.3 the identity of the STPs in the other signaling network to which such transit signaling will be sent.

#### 10.4 SS7 Advanced Intelligent Network (AIN) Access

10.4.1 When technically feasible and upon request by <<customer\_short\_name>>, SS7 AIN Access shall be made available in association with switching. SS7 AIN Access is the provisioning of AIN 0.1 triggers in an equipped BellSouth local switch and interconnection of the BellSouth SS7 network with <<customer\_short\_name>>’s SS7 network to exchange TCAP queries and responses with a <<customer\_short\_name>> SCP.

10.4.2 SS7 AIN Access shall provide <<customer\_short\_name>> SCP access to an equipped BellSouth local switch via interconnection of BellSouth's SS7 and <<customer\_short\_name>> SS7 Networks. BellSouth shall offer SS7 AIN Access through its STPs. If BellSouth requires a mediation device on any part of its network specific to this form of access, BellSouth must route its messages in the same manner. The interconnection arrangement shall result in the BellSouth local switch recognizing the <<customer\_short\_name>> SCP as at least at parity with BellSouth’s SCPs in terms of interfaces, performance and capabilities.

#### 10.4.3 Interface Requirements

10.4.3.1 BellSouth shall provide the following STP options to connect <<customer\_short\_name>> or <<customer\_short\_name>>-designated local switching systems to the BellSouth SS7 network:

10.4.3.1.1 An A-link interface from <<customer\_short\_name>> local switching systems; and,

10.4.3.1.2 A B-link interface from <<customer\_short\_name>> local STPs.

10.4.3.2 Each type of interface shall be provided by one or more layers of signaling links.

10.4.3.3 The Signaling Point of Interconnection for each link shall be located at a cross-connect element in the CO where the BellSouth STP is located. There shall be a DS1 or higher rate transport interface at each of the SPOIs. Each signaling link shall appear as a DS0 channel within the DS1 or higher rate interface.

- 10.4.3.4 BellSouth shall provide intraoffice diversity between the SPOI and BellSouth STPs so that no single failure of intraoffice facilities or equipment shall cause the failure of both B-links in a layer connecting to a BellSouth STP.
- 10.4.3.5 STPs shall provide all functions of the MTP as defined in the applicable industry standard technical references.
- 10.4.4 Message Screening
  - 10.4.4.1 BellSouth shall set message screening parameters so as to accept valid messages from <<customer\_short\_name>> local or tandem switching systems destined to any signaling point within BellSouth's SS7 network where the <<customer\_short\_name>> switching system has a valid signaling relationship.
  - 10.4.4.2 BellSouth shall set message screening parameters so as to pass valid messages from <<customer\_short\_name>> local or tandem switching systems destined to any signaling point or network accessed through BellSouth's SS7 network where the <<customer\_short\_name>> switching system has a valid signaling relationship.
  - 10.4.4.3 BellSouth shall set message screening parameters so as to accept and pass/send valid messages destined to and from <<customer\_short\_name>> from any signaling point or network interconnected through BellSouth's SS7 network where the <<customer\_short\_name>> SCP has a valid signaling relationship.
- 10.5 Service Control Points (SCP)/Databases
  - 10.5.1 Call Related Databases provide the storage of, access to, and manipulation of information required to offer a particular service and/or capability. BellSouth shall provide access to the following Databases: Local Number Portability, LIDB, Toll Free Number Database, Automatic Location Identification/Data Management System, and Calling Name Database. BellSouth also provides access to Service Creation Environment and Service Management System (SCE/SMS) application databases and Directory Assistance.
  - 10.5.2 A SCP is deployed in a SS7 network that executes service application logic in response to SS7 queries sent to it by a switching system also connected to the SS7 network. Service Management Systems provide operational interfaces to allow for provisioning, administration and maintenance of subscriber data and service application data stored in SCPs.
  - 10.5.3 Technical Requirements for SCPs/Databases
    - 10.5.3.1 BellSouth shall provide physical access to SCPs through the SS7 network and protocols with TCAP as the application layer protocol.

- 10.5.3.2 BellSouth shall provide physical interconnection to databases via industry standard interfaces and protocols (e.g. SS7, ISDN and X.25).
- 10.5.3.3 The reliability of interconnection options shall be consistent with requirements for diversity and survivability.
- 10.6 Database Availability
- 10.6.1 Call processing databases shall have a maximum unscheduled availability of 30 minutes per year. Unavailability due to software and hardware upgrades shall be scheduled during minimal usage periods and only be undertaken upon proper notification to providers, which might be impacted. Any downtime associated with the provision of call processing related databases will impact all service providers, including BellSouth, equally.
- 10.6.2 The operational interface provided by BellSouth shall complete Database transactions (i.e., add, modify, delete) for NewSouth customer records stored in BellSouth databases within three (3) business days, or sooner where BellSouth provisions its own customer records within a shorter interval.
- 10.7 Local Number Portability Database
- 10.7.1 The Permanent Number Portability (PNP) database supplies routing numbers for calls involving numbers that have been ported from one local service provider to another. BellSouth agrees to provide access to the PNP database at rates, terms and conditions as set forth by BellSouth and in accordance with an effective FCC or Commission directive.
- 10.8 SS7 Network Interconnection
- 10.8.1 SS7 Network Interconnection is the interconnection of <<customer\_short\_name>> local signaling transfer point switches or <<customer\_short\_name>> local or tandem switching systems with BellSouth signaling transfer point switches. This interconnection provides connectivity that enables the exchange of SS7 messages among BellSouth switching systems and databases, <<customer\_short\_name>> local or tandem switching systems, and other third-party switching systems directly connected to the BellSouth SS7 network.
- 10.8.2 The connectivity provided by SS7 Network Interconnection shall fully support the functions of BellSouth switching systems and databases and <<customer\_short\_name>> or other third-party switching systems with A-link access to the BellSouth SS7 network.
- 10.8.3 If traffic is routed based on dialed or translated digits between a <<customer\_short\_name>> local switching system and a BellSouth or other third-

party local switching system, either directly or via a BellSouth tandem switching system, then it is a requirement that the BellSouth SS7 network convey via SS7 Network Interconnection the TCAP messages that are necessary to provide Call Management services (Automatic Callback, Automatic Recall, and Screening List Editing) between the <<customer\_short\_name>> local signaling transfer point switches and BellSouth or other third-party local switch.

- 10.8.4 SS7 Network Interconnection shall provide:
  - 10.7.4.1 Signaling Data Link functions, as specified in ANSI T1.111.2;
  - 10.7.4.2 Signaling Link functions, as specified in ANSI T1.111.3; and
  - 10.7.4.3 Signaling Network Management functions, as specified in ANSI T1.111.4.
- 10.7.5 SS7 Network Interconnection shall provide all functions of the SCCP necessary for Class 0 (basic connectionless) service as specified in ANSI T1.112. This includes GTT and SCCP Management procedures as specified in ANSI T1.112.4. Where the destination signaling point is a BellSouth switching system or DB, or is another third-party local or tandem switching system directly connected to the BellSouth SS7 network, SS7 Network Interconnection shall include final GTT of messages to the destination and SCCP Subsystem Management of the destination. Where the destination signaling point is a <<customer\_short\_name>> local or tandem switching system, SS7 Network Interconnection shall include intermediate GTT of messages to a gateway pair of <<customer\_short\_name>> local STPs and shall not include SCCP Subsystem Management of the destination.
- 10.7.6 SS7 Network Interconnection shall provide all functions of the Integrated Services Digital Network User Part as specified in ANSI T1.113.
- 10.7.7 SS7 Network Interconnection shall provide all functions of the TCAP as specified in ANSI T1.114.
- 10.7.8 If Internetwork MRVT and SRVT become approved ANSI standards and available capabilities of BellSouth STPs, SS7 Network Interconnection may provide these functions of the OMAP.
- 10.7.9 Interface Requirements
  - 10.7.9.1 The following SS7 Network Interconnection interface options are available to connect <<customer\_short\_name>> or <<customer\_short\_name>>-designated local or tandem switching systems or signaling transfer point switches to the BellSouth SS7 network:
    - 10.7.9.1.1 A-link interface from <<customer\_short\_name>> local or tandem switching systems; and

- 10.7.9.1.2 B-link interface from <<customer\_short\_name>> STPs.
- 10.7.9.2 The Signaling Point of Interconnection for each link shall be located at a cross-connect element in the central office where the BellSouth STP is located. There shall be a DS1 or higher rate transport interface at each of the Signaling Points of interconnection. Each signaling link shall appear as a DS0 channel within the DS1 or higher rate interface.
- 10.7.9.3 BellSouth shall provide intraoffice diversity between the Signaling Points of Interconnection and the BellSouth STP, so that no single failure of intraoffice facilities or equipment shall cause the failure of both B-links in a layer connecting to a BellSouth STP.
- 10.7.9.4 The protocol interface requirements for SS7 Network Interconnection include the MTP, ISDNUP, SCCP, and TCAP. These protocol interfaces shall conform to the applicable industry standard technical references.
- 10.7.9.5 BellSouth shall set message screening parameters to accept messages from <<customer\_short\_name>> local or tandem switching systems destined to any signaling point in the BellSouth SS7 network with which the <<customer\_short\_name>> switching system has a valid signaling relationship.
- 10.7.9.6 SS7 Network Interconnection shall be equal to or better than all of the requirements for SS7 Network Interconnection set forth in the applicable industry standard technical references.

## **11 Automatic Location Identification / Data Management System (ALI/DMS)**

- 11.1 The ALI/DMS Database contains End User information (including name, address, telephone information, and sometimes special information from the local service provider or End User) used to determine to which PSAP to route the call. The ALI/DMS database is used to provide enhanced routing flexibility for E911. <<customer\_short\_name>> will be required to provide BellSouth daily updates to the E911 database. <<customer\_short\_name>> shall also be responsible for providing BellSouth with complete and accurate data for submission to the 911/E911 database for the purpose of providing 911/E911 service to <<customer\_short\_name>>'s End Users.
- 11.2 Technical Requirements
- 11.2.1 BellSouth shall provide <<customer\_short\_name>> the capability of providing updates to the ALI/DMS database. BellSouth shall provide error reports from the ALI/DMS database to <<customer\_short\_name>> after <<customer\_short\_name>> provides End User information for input into the ALI/DMS database.

11.2.2 <<customer\_short\_name>> shall conform to the National Emergency Number Association (NENA) recommended standards for LNP and updating the ALI/DMS database.

## **12 Calling Name Database Service**

12.1 CNAM is the ability to associate a name with the calling party number, allowing the End User (to which a call is being terminated) to view the calling party's name before the call is answered. The calling party's information is accessed by queries launched to the CNAM database. This service also provides <<customer\_short\_name>> the opportunity to load and store its subscriber names in the BellSouth CNAM SCPs.

12.2 <<customer\_short\_name>> shall submit to BellSouth a notice of its intent to access and utilize BellSouth CNAM Database Services. Said notice shall be in writing no less than sixty (60) calendar days prior to <<customer\_short\_name>>'s access to BellSouth's CNAM Database Services and shall be addressed to <<customer\_short\_name>>'s Local Contract Manager.

12.3 BellSouth's provision of CNAM Database Services to <<customer\_short\_name>> requires interconnection from <<customer\_short\_name>> to BellSouth CNAM SCPs. Such interconnections shall be established pursuant to Attachment 3 of this Agreement.

12.4 In order to formulate a CNAM query to be sent to the BellSouth CNAM SCP, <<customer\_short\_name>> shall provide its own CNAM SSP. <<customer\_short\_name>>'s CNAM SSPs must be compliant with TR-NWT-001188, "CLASS Calling Name Delivery Generic Requirements".

12.5 If <<customer\_short\_name>> elects to access the BellSouth CNAM SCP via a third party CCS7 transport provider, the third party CCS7 provider shall interconnect with the BellSouth CCS7 network according to BellSouth's Common Channel Signaling Interconnection Guidelines and Telcordia's CCS Network Interface Specification document, TR-TSV-000905. In addition, the third party provider shall establish CCS7 interconnection at the BellSouth Local Signal Transfer Points (LSTPs) serving the BellSouth CNAM SCPs that <<customer\_short\_name>> desires to query.

12.6 If <<customer\_short\_name>> queries the BellSouth CNAM SCP via a third party national SS7 transport provider, the third party SS7 provider shall interconnect with the BellSouth CCS7 network according to BellSouth's Common Channel Signaling Interconnection Guidelines and Telcordia's CCS Network Interface Specification document, TR-TSV-000905. In addition, the third party provider shall establish SS7 interconnection at one or more of the BellSouth Gateway STPs. The payment of all costs associated with the transport of SS7 signals via a third party will be established by BellSouth and the third party or by mutual agreement of the Parties.

12.7 The mechanism to be used by <<customer\_short\_name>> for initial CNAM record load and/or updates shall be determined by mutual agreement. The initial load and all updates shall be provided by <<customer\_short\_name>> in the BellSouth specified format and shall contain records for every working telephone number that can originate phone calls. It is the responsibility of <<customer\_short\_name>> to provide accurate information to BellSouth on a current basis.

12.8 Updates to the SMS shall occur no less than once a week, reflect service order activity affecting either name or telephone number, and involve only record additions, deletions or changes.

12.9 <<customer\_short\_name>> CNAM records provided for storage in the BellSouth CNAM SCP shall be available, on a SCP query basis only, to all Parties querying the BellSouth CNAM SCP. Further, CNAM service shall be provided by each Party consistent with state and/or federal regulation.

### **13 Service Creation Environment and Service Management System (SCE/SMS) Advanced Intelligent Network Access (AIN Tool Kit)**

13.1 BellSouth's AIN Tool Kit shall provide <<customer\_short\_name>> the capability to create service applications in a BellSouth SCE and deploy those applications in a BellSouth SMS to a BellSouth SCP.

13.2 BellSouth's AIN Tool Kit shall provide access to SCE hardware, software, testing and technical support (e.g., help desk, system administrator) resources available to <<customer\_short\_name>>. Training, documentation, and technical support will address use of SCE and SMS access and administrative functions but will not include support for the creation of a specific service application. Scheduling procedures shall provide <<customer\_short\_name>> with access at parity to these resources.

13.3 BellSouth SCP shall partition and protect <<customer\_short\_name>> service logic and data from unauthorized access.

13.4 When <<customer\_short\_name>> selects AIN Tool Kit, BellSouth shall provide training, documentation, and technical support to enable <<customer\_short\_name>> to use BellSouth's AIN Tool Kit to create and administer applications.

13.5 <<customer\_short\_name>> access will be provided via remote data connection (e.g., dial-in, ISDN).

13.6 BellSouth shall allow <<customer\_short\_name>> to download data forms and/or tables to BellSouth SCP via BellSouth SMS without intervention from BellSouth.

### **14 Operational Support Systems (OSS)**

14.1 [Parties Disagree]

[<<customer\_short\_name>> Version] BellSouth shall provide <<customer\_short\_name>> with nondiscriminatory access to operations support systems on an unbundled basis, in accordance with **47 CFR 51.319(g)** and as set forth in Attachment 6. **Operations support system (“OSS”) functions consist of pre-ordering, ordering, provisioning, maintenance and repair, and billing functions supported by BellSouth’s databases and information. BellSouth, as part of its duty to provide access to the pre-ordering function, shall provide <<customer\_short\_name>> with nondiscriminatory access to the same detailed information about the loop that is available to BellSouth.**

[BellSouth Version] BellSouth shall provide <<customer\_short\_name>> with nondiscriminatory access to operations support systems on an unbundled basis, in accordance **with Attachment 6.**

14.2 Denial/Restoral OSS Charge

14.2.1 In the event <<customer\_short\_name>> provides a list of customers to be denied and restored, rather than an LSR, each location on the list will require a separate PON and therefore will be billed as one LSR per location.

14.3 Cancellation OSS Charge

14.3.1 <<customer\_short\_name>> will incur an OSS charge for an accepted LSR that is later canceled.

14.4 Supplements or clarifications to a previously billed LSR will not incur another OSS charge.

14.5 Network Elements and Other Services Manual Additive

14.6 The Commissions in some states have ordered per element manual additive nonrecurring charges (NRC) for Network Elements and Other Services ordered by means other than one of the interactive interfaces. These ordered Network Elements and Other Services manual additive NRCs will apply in these states, rather than the charge per LSR. The per element charges are listed in Exhibit A of this Attachment.



UNBUNDLED NETWORK ELEMENTS - Kentucky											Attachment: 2		Exhibit: A			
CATEGORY	RATE ELEMENTS	Interim	Zone	BCS	USOC	RATES (\$)	Svc Order Submitted Elec per LSR	Svc Order Submitted Manually per LSR	Incremental Charge - Manual Svc Order vs. Electronic-1st	Incremental Charge - Manual Svc Order vs. Electronic-Add'l	Incremental Charge - Manual Svc Order vs. Electronic-Disc 1st	Incremental Charge - Manual Svc Order vs. Electronic-Disc Add'l				
							Rec	Nonrecurring		Nonrecurring Disconnect		OSS Rates (\$)				
							First	Add'l	First	Add'l	SOMECE	SOMAN	SOMAN	SOMAN	SOMAN	SOMAN
The "Zone" shown in the sections for stand-alone loops or loops as part of a combination refers to Geographically Deaveraged UNE Zones. To view Geographically Deaveraged UNE Zone Designations by Central Office, refer to internet Website: <a href="http://www.interconnection.bellsouth.com/become_a_clec/html/interconnection.htm">http://www.interconnection.bellsouth.com/become_a_clec/html/interconnection.htm</a>																
<b>OPERATIONAL SUPPORT SYSTEMS (OSS) - "REGIONAL RATES"</b>																
NOTE: (1) CLEC should contact its contract negotiator if it prefers the "state specific" OSS charges as ordered by the State Commissions. The OSS charges currently contained in this rate exhibit are the BellSouth "regional" service ordering charges. CLEC may elect either the state specific Commission ordered rates for the service ordering charges, or CLEC may elect the regional service ordering charge, however, CLEC can not obtain a mixture of the two regardless if CLEC has an interconnection contract established in each of the 9 states.																
NOTE: (2) Any element that can be ordered electronically will be billed according to the SOMECE rate listed in this category. Please refer to BellSouth's Local Ordering Handbook (LOH) to determine if a product can be ordered electronically. For those elements that cannot be ordered electronically at present per the LOH, the listed SOMECE rate in this category reflects the charge that would be billed to a CLEC once electronic ordering capabilities come on-line for that element. Otherwise, the manual ordering charge, SOMAN, will be applied to a CLECs bill when it submits an LSR to BellSouth.																
	OSS - Electronic Service Order Charge, Per Local Service Request (LSR) - UNE Only				SOMECE		3.50	0.00	3.50	0.00						
	OSS - Manual Service Order Charge, Per Local Service Request (LSR) - UNE Only				SOMAN		7.86	0.00	0.99	0.00						
<b>UNE SERVICE DATE ADVANCEMENT CHARGE</b>																
NOTE: The Expedite charge will be maintained commensurate with BellSouth's FCC No.1 Tariff, Section 5 as applicable.																
	UNE Expedite Charge per Circuit or Line Assignable USOC, per Day			UAL, UEANL, UCL, UEF, UDF, UEQ, UDL, UENTW, UDN, UEA, UHL, ULC, USL, U1T12, U1T48, U1TD1, U1TD3, U1TDX, U1TO3, U1TS1, U1TVX, UC1BC, UC1BL, UC1CC, UC1CL, UC1DC, UC1DL, UC1EC, UC1EL, UC1FC, UC1FL, UC1GC, UC1GL, UC1HC, UC1HL, UDL12, UDL48, UDLO3, UDLSX, UE3,	SDASP		200.00									
<b>UNBUNDLED EXCHANGE ACCESS LOOP</b>																
<b>2-WIRE ANALOG VOICE GRADE LOOP</b>																
	2-Wire Analog Voice Grade Loop - Service Level 1- Zone 1		1	UEANL	UEAL2	10.56	46.66	22.57	26.65	7.65						
	2-Wire Analog Voice Grade Loop - Service Level 1- Zone 2		2	UEANL	UEAL2	15.34	46.66	22.57	26.65	7.65						
	2-Wire Analog Voice Grade Loop - Service Level 1- Zone 3		3	UEANL	UEAL2	31.11	46.66	22.57	26.65	7.65						
	2-Wire Analog Voice Grade Loop - Service Level 1- Zone 1		1	UEANL	UEASL	10.56	46.66	22.57	26.65	7.65						
	2-Wire Analog Voice Grade Loop - Service Level 1- Zone 2		2	UEANL	UEASL	15.34	46.66	22.57	26.65	7.65						
	2-Wire Analog Voice Grade Loop - Service Level 1- Zone 3		3	UEANL	UEASL	31.11	46.66	22.57	26.65	7.65						
	Unbundled Miscellaneous Rate Element, Tag Loop at End User Premise			UEANL	URETL		8.33	0.83								
	Loop Testing - Basic 1st Half Hour			UEANL	URET1		46.88		46.88							
	Loop Testing - Basic Additional Half Hour			UEANL	URETA		24.16		24.16							
	CLEC to CLEC Conversion Charge Without Outside Dispatch (UVL-SL1)			UEANL	UREWO		15.78		8.94							
	Unbundled Voice Loop, Non-Design Voice Loop, billing for BST providing make-up (Engineering Information - E.I.)			UEANL	UEANM		13.49		13.49							
	Manual Order Coordination for UVL-SL1s (per loop)			UEANL	UEAMC		9.00		9.00							
	Order Coordination for Specified Conversion Time for UVL-SL1 (per LSR)			UEANL	OCOSL		23.01		23.01							
<b>2-WIRE Unbundled COPPER LOOP</b>																
	2-Wire Unbundled Copper Loop - Non-Designed Zone 1	I	1	UEQ	UEQ2X	10.58	44.97	20.89	25.64	6.65						
	2 Wire Unbundled Copper Loop - Non-Designed - Zone 2	I	2	UEQ	UEQ2X	11.51	44.97	20.89	25.64	6.65						
	2 Wire Unbundled Copper Loop - Non-Designed - Zone 3	I	3	UEQ	UEQ2X	13.19	44.97	20.89	25.64	6.65						
	Unbundled Miscellaneous Rate Element, Tag Loop at End User Premise			UEQ	URETL		8.33	0.83								
	Manual Order Coordination 2 Wire Unbundled Copper Loop - Non-Designed (per loop)			UEQ	USBMC		9.00		9.00							

UNBUNDLED NETWORK ELEMENTS - Kentucky														Attachment: 2		Exhibit: A					
CATEGORY	RATE ELEMENTS	Interim	Zone	BCS	USOC	RATES (\$)	Svc Order Submitted Elec per LSR	Svc Order Submitted Manually per LSR	Incremental Charge - Manual Svc Order vs. Electronic-1st	Incremental Charge - Manual Svc Order vs. Electronic-Add'l	Incremental Charge - Manual Svc Order vs. Electronic-Disc 1st	Incremental Charge - Manual Svc Order vs. Electronic-Disc Add'l	OSS Rates (\$)								
													Rec	Nonrecurring		Nonrecurring Disconnect		SOMECE	SOMAN	SOMAN	SOMAN
													First	Add'l	First	Add'l					
	Unbundled Copper Loop, Non-Design Copper Loop, billing for BST providing make-up (Engineering Information - E.I.)			UEQ	UEQMU																
	Loop Testing - Basic 1st Half Hour			UEQ	URET1																
	Loop Testing - Basic Additional Half Hour			UEQ	URETA																
	CLEC to CLEC Conversion Charge Without Outside Dispatch (UCL-ND)			UEQ	UREWO																
<b>UNBUNDLED EXCHANGE ACCESS LOOP</b>																					
<b>2-WIRE ANALOG VOICE GRADE LOOP</b>																					
	2 Wire Analog Voice Grade Loop-Service Level 1-Line Splitting-Zone 1		1	UEPSR UEPSB	UEALS	10.56															
	2 Wire Analog Voice Grade Loop-Service Level 1-Line Splitting-Zone 1		1	UEPSR UEPSB	UEABS	10.56															
	2 Wire Analog Voice Grade Loop- Service Level 1-Line Splitting-Zone 2		2	UEPSR UEPSB	UEALS	15.34															
	2 Wire Analog Voice Grade Loop- Service Level 1-Line Splitting-Zone 2		2	UEPSR UEPSB	UEABS	15.34															
	2 Wire Analog Voice Grade Loop-Service Level 1-Line Splitting-Zone 3		3	UEPSR UEPSB	UEALS	31.11															
	2 Wire Analog Voice Grade Loop-Service Level 1-Line Splitting-Zone 3		3	UEPSR UEPSB	UEABS	31.11															
<b>UNBUNDLED EXCHANGE ACCESS LOOP</b>																					
<b>2-WIRE ANALOG VOICE GRADE LOOP</b>																					
	2-Wire Analog Voice Grade Loop - Service Level 2 w/Loop or Ground Start Signaling - Zone 1		1	UEA	UEAL2	12.67															
	2-Wire Analog Voice Grade Loop - Service Level 2 w/Loop or Ground Start Signaling - Zone 2		2	UEA	UEAL2	17.45															
	2-Wire Analog Voice Grade Loop - Service Level 2 w/Loop or Ground Start Signaling - Zone 3		3	UEA	UEAL2	33.22															
	Order Coordination for Specified Conversion Time (per LSR)			UEA	OCOSL																
	2-Wire Analog Voice Grade Loop - Service Level 2 w/Reverse Battery Signaling - Zone 1		1	UEA	UEAR2	12.67															
	2-Wire Analog Voice Grade Loop - Service Level 2 w/Reverse Battery Signaling - Zone 2		2	UEA	UEAR2	17.45															
	2-Wire Analog Voice Grade Loop - Service Level 2 w/Reverse Battery Signaling - Zone 3		3	UEA	UEAR2	33.22															
	Order Coordination for Specified Conversion Time (per LSR)			UEA	OCOSL																
	CLEC to CLEC Conversion Charge without outside dispatch			UEA	UREWO																
	Loop Tagging - Service Level 2 (SL2)			UEA	URETL																
<b>4-WIRE ANALOG VOICE GRADE LOOP</b>																					
	4-Wire Analog Voice Grade Loop - Zone 1		1	UEA	UEAL4	29.26															
	4-Wire Analog Voice Grade Loop - Zone 2		2	UEA	UEAL4	34.25															
	4-Wire Analog Voice Grade Loop - Zone 3		3	UEA	UEAL4	85.06															
	Order Coordination for Specified Conversion Time (per LSR)			UEA	OCOSL																
	CLEC to CLEC Conversion Charge without outside dispatch			UEA	UREWO																
<b>2-WIRE ISDN DIGITAL GRADE LOOP</b>																					
	2-Wire ISDN Digital Grade Loop - Zone 1		1	UDN	U1L2X	18.44															
	2-Wire ISDN Digital Grade Loop - Zone 2		2	UDN	U1L2X	25.08															
	2-Wire ISDN Digital Grade Loop - Zone 3		3	UDN	U1L2X	42.87															
	Order Coordination For Specified Conversion Time (per LSR)			UDN	OCOSL																
	CLEC to CLEC Conversion Charge without outside dispatch			UDN	UREWO																
<b>2-WIRE ASYMMETRICAL DIGITAL SUBSCRIBER LINE (ADSL) COMPATIBLE LOOP</b>																					
	2 Wire Unbundled ADSL Loop including manual service inquiry & facility reservation - Zone 1		1	UAL	UAL2X	10.82															
	2 Wire Unbundled ADSL Loop including manual service inquiry & facility reservation - Zone 2		2	UAL	UAL2X	11.79															
	2 Wire Unbundled ADSL Loop including manual service inquiry & facility reservation - Zone 3		3	UAL	UAL2X	12.87															
	Order Coordination for Specified Conversion Time (per LSR)			UAL	OCOSL																
	2 Wire Unbundled ADSL Loop without manual service inquiry & facility reservaton - Zone 1		1	UAL	UAL2W	10.82															
	2 Wire Unbundled ADSL Loop without manual service inquiry & facility reservaton - Zone 2		2	UAL	UAL2W	11.79															

UNBUNDLED NETWORK ELEMENTS - Kentucky														Attachment: 2		Exhibit: A		
CATEGORY	RATE ELEMENTS	Interim	Zone	BCS	USOC	RATES (\$)	Svc Order Submitted Elec per LSR	Svc Order Submitted Manually per LSR	Incremental Charge - Manual Svc Order vs. Electronic-1st	Incremental Charge - Manual Svc Order vs. Electronic-Add'l	Incremental Charge - Manual Svc Order vs. Electronic-Disc 1st	Incremental Charge - Manual Svc Order vs. Electronic-Disc Add'l	OSS Rates (\$)					
													Rec	Nonrecurring		Nonrecurring Disconnect		SOME
	2 Wire Unbundled ADSL Loop without manual service inquiry & facility reservation - Zone 3		3	UAL	UAL2W	12.87												
	Order Coordination for Specified Conversion Time (per LSR)			UAL	OCOSL													
	CLEC to CLEC Conversion Charge without outside dispatch			UAL	UREWO													
	<b>2-WIRE HIGH BIT RATE DIGITAL SUBSCRIBER LINE (HDSL) COMPATIBLE LOOP</b>																	
	2 Wire Unbundled HDSL Loop including manual service inquiry & facility reservation - Zone 1		1	UHL	UHL2X	8.75												
	2 Wire Unbundled HDSL Loop including manual service inquiry & facility reservation - Zone 2		2	UHL	UHL2X	9.56												
	2 Wire Unbundled HDSL Loop including manual service inquiry & facility reservation - Zone 3		3	UHL	UHL2X	10.61												
	Order Coordination for Specified Conversion Time (per LSR)			UHL	OCOSL													
	2 Wire Unbundled HDSL Loop without manual service inquiry and facility reservation - Zone 1		1	UHL	UHL2W	8.75												
	2 Wire Unbundled HDSL Loop without manual service inquiry and facility reservation - Zone 2		2	UHL	UHL2W	9.56												
	2 Wire Unbundled HDSL Loop without manual service inquiry and facility reservation - Zone 3		3	UHL	UHL2W	10.61												
	Order Coordination for Specified Conversion Time (per LSR)			UHL	OCOSL													
	CLEC to CLEC Conversion Charge without outside dispatch			UHL	UREWO													
	<b>4-WIRE HIGH BIT RATE DIGITAL SUBSCRIBER LINE (HDSL) COMPATIBLE LOOP</b>																	
	4 Wire Unbundled HDSL Loop including manual service inquiry and facility reservation - Zone 1		1	UHL	UHL4X	13.95												
	4-Wire Unbundled HDSL Loop including manual service inquiry and facility reservation - Zone 2		2	UHL	UHL4X	15.68												
	4-Wire Unbundled HDSL Loop including manual service inquiry and facility reservation - Zone 3		3	UHL	UHL4X	16.98												
	Order Coordination for Specified Conversion Time (per LSR)			UHL	OCOSL													
	4-Wire Unbundled HDSL Loop without manual service inquiry and facility reservation - Zone 1		1	UHL	UHL4W	13.95												
	4-Wire Unbundled HDSL Loop without manual service inquiry and facility reservation - Zone 2		2	UHL	UHL4W	15.68												
	4-Wire Unbundled HDSL Loop without manual service inquiry and facility reservation - Zone 3		3	UHL	UHL4W	16.98												
	Order Coordination for Specified Conversion Time (per LSR)			UHL	OCOSL													
	CLEC to CLEC Conversion Charge without outside dispatch			UHL	UREWO													
	<b>4-WIRE DS1 DIGITAL LOOP</b>																	
	4-Wire DS1 Digital Loop - Zone 1		1	USL	USLXX	86.47												
	4-Wire DS1 Digital Loop - Zone 2		2	USL	USLXX	114.10												
	4-Wire DS1 Digital Loop - Zone 3		3	USL	USLXX	297.76												
	Order Coordination for Specified Conversion Time (per LSR)			USL	OCOSL													
	CLEC to CLEC Conversion Charge without outside dispatch			USL	UREWO													
	<b>4-WIRE 19.2, 56 OR 64 KBPS DIGITAL GRADE LOOP</b>																	
	4 Wire Unbundled Digital 19.2 Kbps		1	UDL	UDL19	27.59												
	4 Wire Unbundled Digital 19.2 Kbps		2	UDL	UDL19	32.48												
	4 Wire Unbundled Digital 19.2 Kbps		3	UDL	UDL19	36.37												
	4 Wire Unbundled Digital Loop 56 Kbps - Zone 1		1	UDL	UDL56	27.59												
	4 Wire Unbundled Digital Loop 56 Kbps - Zone 2		2	UDL	UDL56	32.48												
	4 Wire Unbundled Digital Loop 56 Kbps - Zone 3		3	UDL	UDL56	36.37												
	Order Coordination for Specified Conversion Time (per LSR)			UDL	OCOSL													
	4 Wire Unbundled Digital Loop 64 Kbps - Zone 1		1	UDL	UDL64	27.59												
	4 Wire Unbundled Digital Loop 64 Kbps - Zone 2		2	UDL	UDL64	32.48												
	4 Wire Unbundled Digital Loop 64 Kbps - Zone 3		3	UDL	UDL64	36.37												
	Order Coordination for Specified Conversion Time (per LSR)			UDL	OCOSL													
	CLEC to CLEC Conversion Charge without outside dispatch			UDL	UREWO													
	<b>2-WIRE Unbundled COPPER LOOP</b>																	
	2-Wire Unbundled Copper Loop-Designed including manual service inquiry & facility reservation - Zone 1		1	UCL	UCLPB	10.82												
	2-Wire Unbundled Copper Loop-Designed including manual service inquiry & facility reservation - Zone 2		2	UCL	UCLPB	11.79												
	2 Wire Unbundled Copper Loop-Designed including manual service inquiry & facility reservation - Zone 3		3	UCL	UCLPB	12.87												

UNBUNDLED NETWORK ELEMENTS - Kentucky																
CATEGORY	RATE ELEMENTS	Interim	Zone	BCS	USOC	RATES (\$)	Svc Order Submitted Elec per LSR	Svc Order Submitted Manually per LSR	Attachment: 2		Exhibit: A					
									Incremental Charge - Manual Svc Order vs. Electronic-1st	Incremental Charge - Manual Svc Order vs. Electronic-Add'l	Incremental Charge - Manual Svc Order vs. Electronic-Disc 1st	Incremental Charge - Manual Svc Order vs. Electronic-Disc Add'l				
									Rec	Nonrecurring		Nonrecurring Disconnect		OSS Rates (\$)		
						First	Add'l	First	Add'l	SOME	SOMAN	SOMAN	SOMAN	SOMAN	SOMAN	
	Order Coordination for Unbundled Copper Loops (per loop)			UCL	UCLMC		9.00	9.00								
	2-Wire Unbundled Copper Loop-Designed without manual service inquiry and facility reservation - Zone 1		1	UCL	UCLPW	10.82	120.15	67.97	69.09	11.54						
	2-Wire Unbundled Copper Loop-Designed without manual service inquiry and facility reservation - Zone 2		2	UCL	UCLPW	11.79	120.15	67.97	69.09	11.54						
	2-Wire Unbundled Copper Loop-Designed without manual service inquiry and facility reservation - Zone 3		3	UCL	UCLPW	12.87	120.15	67.97	69.09	11.54						
	Order Coordination for Unbundled Copper Loops (per loop)			UCL	UCLMC		9.00	9.00								
	CLEC to CLEC Conversion Charge without outside dispatch (UCL-Des)			UCL	UREWO		97.23	42.48								
	<b>4-WIRE COPPER LOOP</b>															
	4-Wire Copper Loop-Designed including manual service inquiry and facility reservation - Zone 1		1	UCL	UCL4S	16.92	170.31	108.06	74.95	14.69						
	4-Wire Copper Loop-Designed including manual service inquiry and facility reservation - Zone 2		2	UCL	UCL4S	17.36	170.31	108.06	74.95	14.69						
	4-Wire Copper Loop-Designed including manual service inquiry and facility reservation - Zone 3		3	UCL	UCL4S	28.10	170.31	108.06	74.95	14.69						
	Order Coordination for Unbundled Copper Loops (per loop)			UCL	UCLMC		9.00	9.00								
	4-Wire Copper Loop-Designed without manual service inquiry and facility reservation - Zone 1		1	UCL	UCL4W	16.92	149.52	97.33	74.95	14.69						
	4-Wire Copper Loop-Designed without manual service inquiry and facility reservation - Zone 2		2	UCL	UCL4W	17.36	149.52	97.33	74.95	14.69						
	4-Wire Copper Loop-Designed without manual service inquiry and facility reservation - Zone 3		3	UCL	UCL4W	28.10	149.52	97.33	74.95	14.69						
	Order Coordination for Unbundled Copper Loops (per loop)			UCL	UCLMC		9.00	9.00								
	CLEC to CLEC Conversion Charge without outside dispatch (UCL-Des)			UCL	UREWO		97.23	42.48								
	<b>LOOP MODIFICATION</b>															
	Unbundled Loop Modification, Removal of Load Coils - 2 Wire pair less than or equal to 18k ft, per Unbundled Loop			UAL, UHL, UCL, UEQ, ULS, UEA, UEANL, UEPSR, UEPSB	ULM2L		9.24	9.24								
	Unbundled Loop Modification Removal of Load Coils - 4 Wire less than or equal to 18K ft, per Unbundled Loop			UHL, UCL, UEA	ULM4L		9.24	9.24								
	Unbundled Loop Modification Removal of Bridged Tap Removal, per unbundled loop			UAL, UHL, UCL, UEQ, ULS, UEA, UEANL, UEPSR, UEPSB	ULMBT		10.47	10.47								
	<b>SUB-LOOPS</b>															
	<b>Sub-Loop Distribution</b>															
	Sub-Loop - Per Cross Box Location - CLEC Feeder Facility Set-Up		I	UEANL	USBSA		207.91	207.91								
	Sub-Loop - Per Cross Box Location - Per 25 Pair Panel Set-Up		I	UEANL	USBSB		12.50	12.50								
	Sub-Loop - Per Building Equipment Room - CLEC Feeder Facility Set-Up		I	UEANL	USBSC		80.87	80.87								
	Sub-Loop - Per Building Equipment Room - Per 25 Pair Panel Set-Up		I	UEANL	USBSD		45.04	45.04								
	Sub-Loop Distribution Per 2-Wire Analog Voice Grade Loop - Zone 1		I	1	UEANL	USBN2	6.34	85.03	39.05	59.81	7.90					
	Sub-Loop Distribution Per 2-Wire Analog Voice Grade Loop - Zone 2		I	2	UEANL	USBN2	9.06	85.03	39.05	59.81	7.90					
	Sub-Loop Distribution Per 2-Wire Analog Voice Grade Loop - Zone 3		I	3	UEANL	USBN2	14.82	85.03	39.05	59.81	7.90					
	Order Coordination for Unbundled Sub-Loops, per sub-loop pair			UEANL	USBMC		9.00	9.00								
	Sub-Loop Distribution Per 4-Wire Analog Voice Grade Loop - Zone 1			1	UEANL	USBN4	8.14	102.31	56.32	65.24	10.88					
	Sub-Loop Distribution Per 4-Wire Analog Voice Grade Loop - Zone 2			2	UEANL	USBN4	8.63	102.31	56.32	65.24	10.88					
	Sub-Loop Distribution Per 4-Wire Analog Voice Grade Loop - Zone 3			3	UEANL	USBN4	25.60	102.31	56.32	65.24	10.88					
	Order Coordination for Unbundled Sub-Loops, per sub-loop pair			UEANL	USBMC		9.00	9.00								
	Sub-Loop 2-Wire Intrabuilding Network Cable (INC)		I	UEANL	USBR2		2.57	68.35	22.36	59.81	7.90					

UNBUNDLED NETWORK ELEMENTS - Kentucky														Attachment: 2		Exhibit: A		
CATEGORY	RATE ELEMENTS	Interim	Zone	BCS	USOC	RATES (\$)	Svc Order Submitted Elec per LSR	Svc Order Submitted Manually per LSR	Incremental Charge - Manual Svc Order vs. Electronic-1st	Incremental Charge - Manual Svc Order vs. Electronic-Add'l	Incremental Charge - Manual Svc Order vs. Electronic-Disc 1st	Incremental Charge - Manual Svc Order vs. Electronic-Disc Add'l	OSS Rates (\$)					
													Rec	Nonrecurring		Nonrecurring Disconnect		SOMEc
	Order Coordination for Unbundled Sub-Loops, per sub-loop pair			UEANL	USBMC													
	Sub-Loop 4-Wire IntraBuilding Network Cable (INC)	I		UEANL	USBR4	4.98												
	Order Coordination for Unbundled Sub-Loops, per sub-loop pair			UEANL	USBMC													
	Loop Testing - Basic 1st Half Hour			UEANL	URET1													
	Loop Testing - Basic Additional Half Hour			UEANL	URETA													
	2 Wire Copper Unbundled Sub-Loop Distribution - Zone 1	I	1	UEF	UCS2X	5.45												
	2 Wire Copper Unbundled Sub-Loop Distribution - Zone 2	I	2	UEF	UCS2X	7.06												
	2 Wire Copper Unbundled Sub-Loop Distribution - Zone 3	I	3	UEF	UCS2X	9.67												
	Order Coordination for Unbundled Sub-Loops, per sub-loop pair			UEF	USBMC													
	4 Wire Copper Unbundled Sub-Loop Distribution - Zone 1	I	1	UEF	UCS4X	7.09												
	4 Wire Copper Unbundled Sub-Loop Distribution - Zone 2	I	2	UEF	UCS4X	8.66												
	4 Wire Copper Unbundled Sub-Loop Distribution - Zone 3	I	3	UEF	UCS4X	19.40												
	Order Coordination for Unbundled Sub-Loops, per sub-loop pair			UEF	USBMC													
	Loop Testing - Basic 1st Half Hour			UEF	URET1													
	Loop Testing - Basic Additional Half Hour			UEF	URETA													
	<b>Unbundled Network Terminating Wire (UNTW)</b>																	
	Unbundled Network Terminating Wire (UNTW) per Pair			UENTW	UENPP	0.53												
	<b>Network Interface Device (NID)</b>																	
	Network Interface Device (NID) - 1-2 lines			UENTW	UND12													
	Network Interface Device (NID) - 1-6 lines			UENTW	UND16													
	Network Interface Device Cross Connect - 2 W			UENTW	UNDC2													
	Network Interface Device Cross Connect - 4W			UENTW	UNDC4													
	<b>UNE OTHER, PROVISIONING ONLY - NO RATE</b>																	
	NID - Dispatch and Service Order for NID installation			UENTW	UNDBX	0.00												
	UNTW Circuit Id Establishment, Provisioning Only - No Rate			UENTW	UENCE	0.00												
	Unbundled Contract Name, Provisioning Only - No Rate			UEANL,UEF,UEQ,UE NTW	UNECN	0.00												
	<b>UNE OTHER, PROVISIONING ONLY - NO RATE</b>																	
	Unbundled Contact Name, Provisioning Only - no rate			UAL,UCL,UDC,UDL, UDN,UEA,UHL,ULC	UNECN	0.00												
	Unbundled Sub-Loop Feeder-2 Wire Cross Box Jumper - no rate			UEA,UDN,UCL,UDC	USBFQ	0.00												
	Unbundled Sub-Loop Feeder-4 Wire Cross Box Jumper - no rate			UEA,USL,UCL,UDL	USBFR	0.00												
	Unbundled DS1 Loop - Superframe Format Option - no rate			USL	CCOSF	0.00												
	Unbundled DS1 Loop - Expanded Superframe Format option - no rate			USL	CCOEF	0.00												
	<b>HIGH CAPACITY UNBUNDLED LOCAL LOOP</b>																	
	High Capacity Unbundled Local Loop - DS3 - Per Mile per month			UE3	1L5ND	9.25												
	High Capacity Unbundled Local Loop - DS3 - Facility Termination per month			UE3	UE3PX	308.31												
	High Capacity Unbundled Local Loop - STS-1 - Per Mile per month			UDLSX	1L5ND	9.25												
	High Capacity Unbundled Local Loop - STS-1 - Facility Termination per month			UDLSX	UDLS1	320.51												
	<b>LOOP MAKE-UP</b>																	
	Loop Makeup - Preordering Without Reservation, per working or spare facility queried (Manual).			UMK	UMK1W													
	Loop Makeup - Preordering With Reservation, per spare facility queried (Manual).			UMK	UMK1P													
	Loop Makeup-With or Without Reservation, per working or spare facility queried (Mechanized)			UMK	UMKMQ													
	<b>LINE SHARING AND LINE SPLITTING</b>																	
	NOTE 1: The Line Sharing monthly recurring rates for all installations completed from October 02, 2003 through midnight October 01, 2004 shall be billed as follows:																	
	NOTE 1: 10/02/2003 - 10/01/2004: 25% of the rate for an unbundled copper loop non-designed ("UCLND")																	
	NOTE 1: 10/02/2004 - 10/01/2005: 50% of the rate for UCLND																	
	NOTE 1: 10/02/2005 - 10/01/2006: 75% of the rate for UCLND																	
	NOTE 1: Above will apply to USOCs: ULSDT and ULSCT																	
	**NOTE 2: The Line Sharing monthly recurring rates with USOCs ULSDC and ULSCC applies only to circuits installed and inservice on or before October 1, 2003																	
	<b>LINE SHARING</b>																	
	<b>SPLITTERS-CENTRAL OFFICE BASED</b>																	
	Line Sharing Splitter, per System 96 Line Capacity			ULS	ULSDA	198.83												
	Line Sharing Splitter, per System 24 Line Capacity			ULS	ULSDB	49.71												

UNBUNDLED NETWORK ELEMENTS - Kentucky														Attachment: 2		Exhibit: A		
CATEGORY	RATE ELEMENTS	Interim	Zone	BCS	USOC	RATES (\$)	Svc Order Submitted Elec per LSR	Svc Order Submitted Manually per LSR	Incremental Charge - Manual Svc Order vs. Electronic-1st	Incremental Charge - Manual Svc Order vs. Electronic-Add'l	Incremental Charge - Manual Svc Order vs. Electronic-Disc 1st	Incremental Charge - Manual Svc Order vs. Electronic-Disc Add'l	OSS Rates (\$)					
													Rec	Nonrecurring		Nonrecurring Disconnect		SOMECE
	Line Sharing Splitter, Per System, 8 Line Capacity			ULS	ULSD8	16.94		377.71	0.00	357.29	0.00							
	Line Sharing-DLEC Owned Splitter in CO-CFA activation-deactivation (per LSOD)			ULS	ULSDG			173.62	0.00	100.40	0.00							
	<b>END USER ORDERING-CENTRAL OFFICE BASED LINE SHARING</b>																	
	Line Sharing - per Line Activation (BST Owned splitter) - OBSOLETE see **NOTE 2			ULS	ULSDC	0.61		37.16	21.28	20.17	9.90							
	Line Share Service, TRO per line activation, BST owned splitter - Central Office Located (25% of UCLND) - please see NOTE 1 (E:10/2/2003)			ULS	ULSDT	2.65		37.16	21.28	20.17	9.90							
	Line Share Service, TRO per line activation, BST owned splitter - Central Office Located (50% of UCLND) - please see NOTE 1 (E:10/2/2004)			ULS	ULSDT	5.29		37.16	21.28	20.17	9.90							
	Line Share Service, TRO per line activation, BST owned splitter - Central Office Located (75% of UCLND) - please see NOTE 1 (E:10/2/2005)			ULS	ULSDT	7.94		37.16	21.28	20.17	9.90							
	Line Sharing - per Subsequent Activity per Line Rearrangement(BST Owned Splitter)			ULS	ULSDS			32.90	16.43									
	Line Sharing - per Subsequent Activity per Line Rearrangement(DLEC Owned Splitter)			ULS	ULSCS			32.90	16.43									
	Line Sharing - per Line Activation (DLEC owned Splitter) - OBSOLETE see **NOTE 2			ULS	ULSCC	0.61		47.44	19.31	20.67	12.74							
	Line Share Service, TRO per line activation, CLEC owned splitter - Central Office Located (25% of UCLND) - please see NOTE 1 (E:10/2/2003)			ULS	ULSCT	2.65		47.44	19.31	20.67	12.74							
	Line Share Service, TRO per line activation, CLEC owned splitter - Central Office Located (50% of UCLND) - please see NOTE 1 (E:10/2/2004)			ULS	ULSCT	5.29		47.44	19.31	20.67	12.74							
	Line Share Service, TRO per line activation, CLEC owned splitter - Central Office Located (75% of UCLND) - please see NOTE 1 (E:10/2/2005)			ULS	ULSCT	7.94		47.44	19.31	20.67	12.74							
	<b>LINE SPLITTING</b>																	
	<b>END USER ORDERING-CENTRAL OFFICE BASED</b>																	
	Line Splitting - per line activation DLEC owned splitter			UEPSR UEPSB	UREOS	0.61												
	Line Splitting - per line activation BST owned - physical			UEPSR UEPSB	UREBP	0.61		37.02	21.20	21.10	9.87							
	Line Splitting - per line activation BST owned - virtual			UEPSR UEPSB	UREBV	0.61		37.02	21.20	21.10	9.87							
	<b>MAINTENANCE</b>																	
	No Trouble Found - per 1/2 hour increments - Basic							80.00	55.00									
	No Trouble Found - per 1/2 hour increments - Overtime							120.00	82.50									
	No Trouble Found - per 1/2 hour increments - Premium							160.00	110.00									
	<b>UNBUNDLED DEDICATED TRANSPORT</b>																	
	<b>INTEROFFICE CHANNEL - DEDICATED TRANSPORT</b>																	
	Interoffice Channel - Dedicated Transport - 2-Wire Voice Grade - Per Mile per month			U1TVX	1L5XX	0.01												
	Interoffice Channel - Dedicated Transport- 2- Wire Voice Grade - Facility Termination			U1TVX	U1TV2	29.11		47.34	31.78	22.77	8.75							
	Interoffice Channel - Dedicated Transport- 2-Wire Voice Grade Rev Bat. - Per Mile per month			U1TVX	1L5XX	0.01												
	Interoffice Channel - Dedicated Transport- 2- Wire VG Rev Bat. - Facility Termination			U1TVX	U1TR2	29.11		47.34	31.78	22.77	8.75							
	Interoffice Channel - Dedicated Transport - 4-Wire Voice Grade - Per Mile per month			U1TVX	1L5XX	0.01												
	Interoffice Channel - Dedicated Transport - 4- Wire Voice Grade - Facility Termination			U1TVX	U1TV4	25.86		47.34	31.78	22.77	8.75							
	Interoffice Channel - Dedicated Transport - 56 kbps - per mile per month			U1TDX	1L5XX	0.0115												
	Interoffice Channel - Dedicated Transport - 56 kbps - Facility Termination			U1TDX	U1TD5	20.97		47.35	31.78	22.77	8.75							
	Interoffice Channel - Dedicated Transport - 64 kbps - per mile per month			U1TDX	1L5XX	0.0115												
	Interoffice Channel - Dedicated Transport - 64 kbps - Facility Termination			U1TDX	U1TD6	20.97		47.35	31.78	22.77	8.75							

UNBUNDLED NETWORK ELEMENTS - Kentucky														Attachment: 2		Exhibit: A				
CATEGORY	RATE ELEMENTS	Interim	Zone	BCS	USOC	RATES (\$)	Svc Order Submitted Elec per LSR	Svc Order Submitted Manually per LSR	Incremental Charge - Manual Svc Order vs. Electronic-1st	Incremental Charge - Manual Svc Order vs. Electronic-Add'l	Incremental Charge - Manual Svc Order vs. Electronic-Disc 1st	Incremental Charge - Manual Svc Order vs. Electronic-Disc Add'l	OSS Rates (\$)							
													Rec	Nonrecurring		Nonrecurring Disconnect		SOMEC	SOMAN	SOMAN
													First	Add'l	First	Add'l				
	Interoffice Channel - Dedicated Channel - DS1 - Per Mile per month			U1TD1	1L5XX	0.23														
	Interoffice Channel - Dedicated Transport - DS1 - Facility Termination			U1TD1	U1TF1	96.04	105.52	98.46	23.09	20.49										
	Interoffice Channel - Dedicated Transport - DS3 - Per Mile per month			U1TD3	1L5XX	4.97														
	Interoffice Channel - Dedicated Transport - DS3 - Facility Termination per month			U1TD3	U1TF3	1,175.15	335.40	219.24	89.57	87.75										
	Interoffice Channel - Dedicated Transport - STS-1 - Per Mile per month			U1TS1	1L5XX	4.97														
	Interoffice Channel - Dedicated Transport - STS-1 - Facility Termination			U1TS1	U1TFS	1,149.51	335.40	219.24	89.57	87.75										
<b>DARK FIBER</b>																				
	Dark Fiber, Four Fiber Strands, Per Route Mile or Fraction Thereof per month - Interoffice Channel			UDF, UDFCX	1L5DF	30.74														
	NRC Dark Fiber - Interoffice Channel			UDF, UDFCX	UDF14		732.53	192.67	377.27	241.67										
	Dark Fiber, Four Fiber Strands, Per Route Mile or Fraction Thereof per month - Local Loop			UDF, UDFCX	1L5DL	47.01														
	NRC Dark Fiber - Local Loop			UDF, UDFCX	UDFL4		732.53	192.67	377.27	241.67										
<b>8XX ACCESS TEN DIGIT SCREENING</b>																				
	8XX Access Ten Digit Screening, Per Call			OHD		0.0006478														
	8XX Access Ten Digit Screening, Reservation Charge Per 8XX Number Reserved			OHD	N8R1X		4.14	0.70												
	8XX Access Ten Digit Screening, Per 8XX No. Established W/O POTS Translations			OHD			8.78	1.18	7.08	0.86										
	8XX Access Ten Digit Screening, Per 8XX No. Established With POTS Translations			OHD	N8FTX		8.78	1.18	7.08	0.86										
	8XX Access Ten Digit Screening, Customized Area of Service Per 8XX Number			OHD	N8FCX		4.14	2.07												
	8XX Access Ten Digit Screening, Multiple InterLATA CXR Routing Per CXR Requested Per 8XX No.			OHD	N8FMX		4.85	2.78												
	8XX Access Ten Digit Screening, Change Charge Per Request			OHD	N8FAX		4.85	0.70												
	8XX Access Ten Digit Screening, Call Handling and Destination Features			OHD	N8FDX		4.14	4.14												
	8XX Access Ten Digit Screening w/ 8FL No. Delivery,			OHD		0.0006478														
	8XX Access Ten Digit Screening, w/ POTS No. Delivery,			OHD		0.0006478														
<b>LINE INFORMATION DATA BASE ACCESS (LIDB)</b>																				
	LIDB Common Transport Per Query			OQT		0.000023														
	LIDB Validation Per Query			OQU		0.0137322														
	LIDB Originating Point Code Establishment or Change			OQT, OQU	NRBPX		55.12		67.59											
<b>SIGNALING (CCS7)</b>																				
	CCS7 Signaling Connection, Per 56 Kbps Facility			UDB	TPP++	20.71	43.56	43.56	22.45	22.45										
	CCS7 Signaling Termination, Per STP Port			UDB	PT8SX	151.39														
	CCS7 Signaling Usage, Per TCAP Message			UDB		0.0000656														
	CCS7 Signaling Connection, Per link (A link)			UDB	TPP++	20.71	43.56	43.56	22.45	22.45										
	CCS7 Signaling Connection, Per link (B link) (also known as D link)			UDB	TPP++	20.71	43.56	43.56	22.45	22.45										
	CCS7 Signaling Usage, Per ISUP Message			UDB		0.0000164														
	CCS7 Signaling Usage Surrogate, per link per LATA			UDB	STU56	751.08														
	CCS7 Signaling Point Code, per Originating Point Code Establishment or Change, per STP affected			UDB	CCAPO		46.02	46.02	56.43	56.43										
	CCS7 Signaling Point Code, per Destination Point Code Establishment or Change, Per Stp Affected			UDB	CCAPD		46.02	46.02	56.43	56.43										
<b>E911 SERVICE</b>																				
	Local Channel - Dedicated - 2-wr Voice Grade					18.57	265.78	46.96	46.79	4.98										
	Interoffice Transport - Dedicated - 2-wr Voice Grade Per Mile					0.0115														
	Interoffice Transport - Dedicated - 2-wr Voice Grade Per Facility Termination					29.11	47.34	31.78	22.77	8.75										
	Local Channel - Dedicated - DS1 - Zone 1					40.46	209.60	176.51	30.21	21.07										
	Local Channel - Dedicated - DS1 - Zone 2					43.39	209.60	176.51	30.21	21.07										
	Local Channel - Dedicated - DS1 - Zone 3					164.50	209.60	176.51	30.21	21.07										
	Interoffice Transport - Dedicated - DS1 Per Mile					0.23														

UNBUNDLED NETWORK ELEMENTS - Kentucky																
CATEGORY	RATE ELEMENTS	Interim	Zone	BCS	USOC	RATES (\$)	Svc Order Submitted Elec per LSR	Svc Order Submitted Manually per LSR	Attachment: 2		Exhibit: A					
									Incremental Charge - Manual Svc Order vs. Electronic-1st	Incremental Charge - Manual Svc Order vs. Electronic-Add'l	Incremental Charge - Manual Svc Order vs. Electronic-Disc 1st	Incremental Charge - Manual Svc Order vs. Electronic-Disc Add'l				
							Rec	Nonrecurring		Nonrecurring Disconnect		OSS Rates (\$)				
								First	Add'l	First	Add'l	SOME	SOMAN	SOMAN	SOMAN	SOMAN
	Interoffice Transport - Dedicated - DS1 Per Facility Termination					96.04		105.52	98.46	23.09	20.49					
<b>CALLING NAME (CNAM) SERVICE</b>																
	CNAM For DB Owners - Service Establishment			OQV				25.34	25.34	23.30	23.30					
	CNAM For Non DB Owners - Service Establishment			OQV				25.34	25.34	23.30	23.30					
	CNAM For DB Owners - Service Provisioning With Point Code Establishment			OQV				1,591.54	1,177.08	431.95	317.61					
	CNAM For Non DB Owners - Service Provisioning With Point Code Establishment			OQV				546.40	393.74	438.93	317.61					
	CNAM for DB Owners, Per Query			OQV		0.0010348										
	CNAM for Non DB Owners, Per Query			OQV		0.0010348										
	CNAM (Non-Databs Owner), NRC, applies when using the Character Based User Interface (CHUI)			OQV	CDDCH	595.00		595.00								
<b>SELECTIVE ROUTING</b>																
	Selective Routing Per Unique Line Class Code Per Request Per Switch							93.53	93.53	15.58	15.58					
<b>VIRTUAL COLLOCATION</b>																
	Virtual Collocation-2 Wire Cross Connects (Loop) for Line Splitting			UEPSR UEPSB	VE1LS	0.0309		24.68	23.68	12.14	10.95					
<b>PHYSICAL COLLOCATION</b>																
	Physical Collocation-2 Wire Cross Connects (Loop) for Line Splitting			UEPSR UEPSB	PE1LS	0.0333		24.68	23.68	12.14	10.95					
<b>AIN SELECTIVE CARRIER ROUTING</b>																
	Regional Service Establishment			SRC	SRCEC			193,401.00	193,401.00	9,483.34	9,483.34					
	End Office Establishment			SRC	SRCEO			194.09	194.09	0.85	0.85					
	Line/Port NRC, per end user			SRC	SRCLP			2.06	2.06							
	Query NRC, per query			SRC		0.0037502										
<b>AIN - BELLSOUTH AIN SMS ACCESS SERVICE</b>																
	AIN SMS Access Service - Service Establishment, Per State, Initial Setup			A1N	CAMSE			43.55	43.55	44.93	44.93					
	AIN SMS Access Service - Port Connection - Dial/Shared Access			A1N	CAMDP			8.64	8.64	10.03	10.03					
	AIN SMS Access Service - Port Connection - ISDN Access			A1N	CAM1P			8.64	8.64	10.03	10.03					
	AIN SMS Access Service - User Identification Codes - Per User ID Code			A1N	CAMAU			38.65	38.65	29.88	29.88					
	AIN SMS Access Service - Security Card, Per User ID Code, Initial or Replacement			A1N	CAMRC			75.08	75.08	12.93	12.93					
	AIN SMS Access Service - Storage, Per Unit (100 Kilobytes)					0.0025										
	AIN SMS Access Service - Session, Per Minute					0.666										
	AIN SMS Access Service - Company Performed Session, Per Minute					0.4608										
<b>AIN - BELLSOUTH AIN TOOLKIT SERVICE</b>																
	AIN Toolkit Service - Service Establishment Charge, Per State, Initial Setup			CAM	BAPSC			43.55	43.55	44.93	44.93					
	AIN Toolkit Service - Training Session, Per Customer				BAPVX			8,436.93	8,436.93							
	AIN Toolkit Service - Trigger Access Charge, Per Trigger, Per DN, Term, Attempt				BAPTT			8.64	8.64	10.03	10.03					
	AIN Toolkit Service - Trigger Access Charge, Per Trigger, Per DN, Off-Hook Delay				BAPTD			8.64	8.64	10.03	10.03					
	AIN Toolkit Service - Trigger Access Charge, Per Trigger, Per DN, Off-Hook Immediate				BAPTM			8.64	8.64	10.03	10.03					
	AIN Toolkit Service - Trigger Access Charge, Per Trigger, Per DN, 10-Digit PODP				BAPTO			51.01	51.01	18.50	18.50					
	AIN Toolkit Service - Trigger Access Charge, Per Trigger, Per DN, CDP				BAPTC			51.01	51.01	18.50	18.50					
	AIN Toolkit Service - Trigger Access Charge, Per Trigger, Per DN, Feature Code				BAPTF			51.01	51.01	18.50	18.50					
	AIN Toolkit Service - Query Charge, Per Query					0.0549207										
	AIN Toolkit Service - Type 1 Node Charge, Per AIN Toolkit Subscription, Per Node, Per Query					0.0066492										
	AIN Toolkit Service - SCP Storage Charge, Per SMS Access Account, Per 100 Kilobytes					0.07										



UNBUNDLED NETWORK ELEMENTS - Kentucky														Attachment: 2		Exhibit: A		
CATEGORY	RATE ELEMENTS	Interim	Zone	BCS	USOC	RATES (\$)	Svc Order Submitted Elec per LSR	Svc Order Submitted Manually per LSR	Incremental Charge - Manual Svc Order vs. Electronic-1st	Incremental Charge - Manual Svc Order vs. Electronic-Add'l	Incremental Charge - Manual Svc Order vs. Electronic-Disc 1st	Incremental Charge - Manual Svc Order vs. Electronic-Disc Add'l	OSS Rates (\$)					
													Rec	Nonrecurring		Nonrecurring Disconnect		SOME
	AIN Toolkit Service - Monthly report - Per AIN Toolkit Service Subscription			CAM	BAPMS	7.87		8.64	8.64		6.08	6.08						
	AIN Toolkit Service - Special Study - Per AIN Toolkit Service Subscription			CAM	BAPLS	3.26		9.56	9.56									
	AIN Toolkit Service - Call Event Report - Per AIN Toolkit Service Subscription			CAM	BAPDS	4.72		8.64	8.64		6.08	6.08						
	AIN Toolkit Service - Call Event Special Study - Per AIN Toolkit Service Subscription			CAM	BAPES	0.11		9.56	9.56									
<b>ENHANCED EXTENDED LINK (EELs)</b>																		
<b>NOTE: The monthly recurring and non-recurring charges below will apply and the Switch-As-Is Charge will not apply for UNE combinations provisioned as ' Ordinarily Combined' Network Elements.</b>																		
<b>NOTE: The monthly recurring and the Switch-As-Is Charge and not the non-recurring charges below will apply for UNE combinations provisioned as ' Currently Combined' Network Elements.</b>																		
<b>EXTENDED 2-WIRE VOICE GRADE EXTENDED LOOP WITH DEDICATED DS1 INTEROFFICE TRANSPORT</b>																		
	First 2-Wire VG Loop (SL2) in Combination - Zone 1		1	UNCVX	UEAL2	12.67	125.22	60.48	59.69	7.84								
	First 2-Wire VG Loop (SL2) in Combination - Zone 2		2	UNCVX	UEAL2	17.45	125.22	60.48	59.69	7.84								
	First 2-Wire VG Loop (SL2) in Combination - Zone 3		3	UNCVX	UEAL2	33.22	125.22	60.48	59.69	7.84								
	Interoffice Transport - Dedicated - DS1 combination - Per Mile per month			UNC1X	1L5XX	0.19												
	Interoffice Transport - Dedicated - DS1 combination - Facility Termination per month			UNC1X	U1TF1	79.02	181.24	123.53	56.72	22.32								
	1/0 Channelization System in combination Per Month			UNC1X	MQ1	113.33	57.26	14.74	1.86	1.67								
	Voice Grade COCI - Per Month			UNCVX	1D1VG	0.62	6.71	4.84										
	Each Additional 2-Wire VG Loop (SL 2) in Combination - Zone 1		1	UNCVX	UEAL2	12.67	125.22	60.48	59.69	7.84								
	Each Additional 2-Wire VG Loop (SL 2) in Combination - Zone 2		2	UNCVX	UEAL2	17.45	125.22	60.48	59.69	7.84								
	Each Additional 2-Wire VG Loop (SL 2) in Combination - Zone 3		3	UNCVX	UEAL2	33.22	125.22	60.48	59.69	7.84								
	Voice Grade COCI - Per Month			UNCVX	1D1VG	0.62	6.71	4.84										
	Nonrecurring Currently Combined Network Elements Switch -As-Is Charge			UNC1X	UNCCC		8.98	8.98	11.17	11.17								
<b>EXTENDED 4-WIRE VOICE GRADE EXTENDED LOOP WITH DEDICATED DS1 INTEROFFICE TRANSPORT</b>																		
	First 4-Wire Analog Voice Grade Loop in Combination - Zone 1		1	UNCVX	UEAL4	29.26	125.22	60.48	59.69	7.84								
	First 4-Wire Analog Voice Grade Loop in Combination - Zone 2		2	UNCVX	UEAL4	34.25	125.22	60.48	59.69	7.84								
	First 4-Wire Analog Voice Grade Loop in Combination - Zone 3		3	UNCVX	UEAL4	85.06	125.22	60.48	59.69	7.84								
	Interoffice Transport - Dedicated - DS1 combination - Per Mile Per Month			UNC1X	1L5XX	0.19												
	Interoffice Transport - Dedicated - DS1 - Facility Termination Per Month			UNC1X	U1TF1	79.02	181.24	123.53	56.72	22.32								
	1/0 Channel System in combination Per Month			UNC1X	MQ1	113.33	57.26	14.74	1.86	1.67								
	Voice Grade COCI in combination - per month			UNCVX	1D1VG	0.62	6.71	4.84										
	Additional 4-Wire Analog Voice Grade Loop in same DS1 Interoffice Transport Combination - Zone 1		1	UNCVX	UEAL4	29.26	125.22	60.48	59.69	7.84								
	Additional 4-Wire Analog Voice Grade Loop in same DS1 Interoffice Transport Combination - Zone 2		2	UNCVX	UEAL4	34.25	125.22	60.48	59.69	7.84								
	Additional 4-Wire Analog Voice Grade Loop in same DS1 Interoffice Transport Combination - Zone 3		3	UNCVX	UEAL4	85.06	125.22	60.48	59.69	7.84								
	Additional Voice Grade COCI in combination - per month			UNCVX	1D1VG	0.62	6.71	4.84										
	Nonrecurring Currently Combined Network Elements Switch -As-Is Charge			UNC1X	UNCCC		8.98	8.98	11.17	11.17								
<b>EXTENDED 4-WIRE 56 KBPS EXTENDED DIGITAL LOOP WITH DEDICATED DS1 INTEROFFICE TRANSPORT</b>																		
	First 4-Wire 56Kbps Digital Grade Loop in Combination - Zone 1		1	UNCDX	UDL56	27.59	125.22	60.48	59.69	7.84								
	First 4-Wire 56Kbps Digital Grade Loop in Combination - Zone 2		2	UNCDX	UDL56	32.48	125.22	60.48	59.69	7.84								
	First 4-Wire 56Kbps Digital Grade Loop in Combination - Zone 3		3	UNCDX	UDL56	36.37	125.22	60.48	59.69	7.84								
	Interoffice Transport - Dedicated - DS1 combination - Per Mile Per Month			UNC1X	1L5XX	0.19												
	Interoffice Transport - Dedicated - DS1 - combination Facility Termination Per Month			UNC1X	U1TF1	79.02	181.24	123.53	56.72	22.32								
	1/0 Channel System in combination Per Month			UNC1X	MQ1	113.33	57.26	14.74	1.86	1.67								
	OCU-DP COCI (data) per month (2.4-64kbs)			UNCDX	1D1DD	1.32	6.71	4.84										
	Additional 4-Wire 56Kbps Digital Grade Loop in same DS1 Interoffice Transport Combination - Zone 1		1	UNCDX	UDL56	27.59	125.22	60.48	59.69	7.84								
	Additional 4-Wire 56Kbps Digital Grade Loop in same DS1 Interoffice Transport Combination - Zone 2		2	UNCDX	UDL56	32.48	125.22	60.48	59.69	7.84								
	Additional 4-Wire 56Kbps Digital Grade Loop in same DS1 Interoffice Transport Combination - Zone 3		3	UNCDX	UDL56	36.37	125.22	60.48	59.69	7.84								

UNBUNDLED NETWORK ELEMENTS - Kentucky														Attachment: 2		Exhibit: A		
CATEGORY	RATE ELEMENTS	Interim	Zone	BCS	USOC	RATES (\$)	Svc Order Submitted Elec per LSR	Svc Order Submitted Manually per LSR	Incremental Charge - Manual Svc Order vs. Electronic-1st	Incremental Charge - Manual Svc Order vs. Electronic-Add'l	Incremental Charge - Manual Svc Order vs. Electronic-Disc 1st	Incremental Charge - Manual Svc Order vs. Electronic-Disc Add'l	OSS Rates (\$)					
													Rec	Nonrecurring		Nonrecurring Disconnect		SOMEc
	Additional OCU-DP COCI (data) - in combination per month (2.4-64kbs)			UNCDX	1D1DD	1.32	6.71	4.84										
	Nonrecurring Currently Combined Network Elements Switch -As-Is Charge			UNC1X	UNCCC		8.98	8.98	11.17	11.17								
<b>EXTENDED 4-WIRE 64 KBPS EXTENDED DIGITAL LOOP WITH DEDICATED DS1 INTEROFFICE TRANSPORT</b>																		
	First 4-Wire 64Kbps Digital Grade Loop in Combination - Zone 1		1	UNCDX	UDL64	27.59	125.22	60.48	59.69	7.84								
	First 4-Wire 64Kbps Digital Grade Loop in Combination - Zone 2		2	UNCDX	UDL64	32.48	125.22	60.48	59.69	7.84								
	First 4-Wire 64Kbps Digital Grade Loop in Combination - Zone 3		3	UNCDX	UDL64	36.37	125.22	60.48	59.69	7.84								
	Interoffice Transport - Dedicated - DS1 combination - Per Mile Per Month			UNC1X	1L5XX	0.19												
	interoffice Transport - Dedicated - DS1 combination - Facility Termination Per Month			UNC1X	U1TF1	79.02	181.24	123.53	56.72	22.32								
	1/0 Channel System in combination Per Month			UNC1X	MQ1	113.33	57.26	14.74	1.86	1.67								
	OCU-DP COCI (data) - in combination - per month (2.4-64kbs)			UNCDX	1D1DD	1.32	6.71	4.84										
	Additional 4-Wire 64Kbps Digital Grade Loop in same DS1 Interoffice Transport Combination - Zone 1		1	UNCDX	UDL64	27.59	125.22	60.48	59.69	7.84								
	Additional 4-Wire 64Kbps Digital Grade Loop in same DS1 Interoffice Transport Combination - Zone 2		2	UNCDX	UDL64	32.48	125.22	60.48	59.69	7.84								
	Additional 4-Wire 64Kbps Digital Grade Loop in same DS1 Interoffice Transport Combination - Zone 3		3	UNCDX	UDL64	36.37	125.22	60.48	59.69	7.84								
	Additional OCU-DP COCI (data) - in combination - per month (2.4-64kbs)			UNCDX	1D1DD	1.32	6.71	4.84										
	Nonrecurring Currently Combined Network Elements Switch -As-Is Charge			UNC1X	UNCCC		8.98	8.98	11.17	11.17								
<b>EXTENDED 4-WIRE DS1 DIGITAL EXTENDED LOOP WITH DEDICATED DS1 INTEROFFICE TRANSPORT</b>																		
	4-Wire DS1 Digital Loop in Combination - Zone 1		1	UNC1X	USLXX	86.47	210.70	114.60	63.96	17.97								
	4-Wire DS1 Digital Loop in Combination - Zone 2		2	UNC1X	USLXX	114.10	210.70	114.60	63.96	17.97								
	4-Wire DS1 Digital Loop in Combination - Zone 3		3	UNC1X	USLXX	297.76	210.70	114.60	63.96	17.97								
	Interoffice Transport - Dedicated - DS1 combination - Per Mile Per Month			UNC1X	1L5XX	0.19												
	Interoffice Transport - Dedicated - DS1 combination - Facility Termination Per Month			UNC1X	U1TF1	79.02	181.24	123.53	56.72	22.32								
	Nonrecurring Currently Combined Network Elements Switch -As-Is Charge			UNC1X	UNCCC		8.98	8.98	11.17	11.17								
<b>EXTENDED 4-WIRE DS1 DIGITAL EXTENDED LOOP WITH DEDICATED DS3 INTEROFFICE TRANSPORT</b>																		
	First DS1Loop in Combination - Zone 1		1	UNC1X	USLXX	86.47	210.70	114.60	63.96	17.97								
	First DS1Loop in Combination - Zone 2		2	UNC1X	USLXX	114.10	210.70	114.60	63.96	17.97								
	First DS1Loop in Combination - Zone 3		3	UNC1X	USLXX	297.76	210.70	114.60	63.96	17.97								
	Interoffice Transport - Dedicated - DS3 combination - Per Mile Per Month			UNC3X	1L5XX	4.09												
	Interoffice Transport - Dedicated - DS3 - Facility Termination per month			UNC3X	U1TF3	966.89	350.56	141.58	48.00	23.39								
	3/1Channel System in combination per month			UNC3X	MQ3	158.20	115.48	56.53	15.12	5.30								
	DS1 COCI in combination per month			UNC1X	UC1D1	11.80	6.71	4.84										
	Additional DS1Loop in DS3 Interoffice Transport Combination - Zone 1		1	UNC1X	USLXX	86.47	210.70	114.60	63.96	17.97								
	Additional DS1Loop in DS3 Interoffice Transport Combination - Zone 2		2	UNC1X	USLXX	114.10	210.70	114.60	63.96	17.97								
	Additional DS1Loop in DS3 Interoffice Transport Combination - Zone 3		3	UNC1X	USLXX	297.76	210.70	114.60	63.96	17.97								
	Additional DS1 COCI in combination per month			UNC1X	UC1D1	11.80	6.71	4.84										
	Nonrecurring Currently Combined Network Elements Switch -As-Is Charge			UNC3X	UNCCC		8.98	8.98	11.17	11.17								
<b>EXTENDED 2-WIRE VOICE GRADE EXTENDED LOOP/ 2 WIRE VOICE GRADE INTEROFFICE TRANSPORT</b>																		
	2-WireVG Loop in combination - Zone 1		1	UNCVX	UEAL2	12.67	125.22	60.48	59.69	7.84								
	2-WireVG Loop in combination - Zone 2		2	UNCVX	UEAL2	17.45	125.22	60.48	59.69	7.84								
	2-WireVG Loop in combination - Zone 3		3	UNCVX	UEAL2	33.22	125.22	60.48	59.69	7.84								
	Interoffice Transport - 2-wire VG - Dedicated- Per Mile Per Month			UNCVX	1L5XX	0.01												
	Interoffice Transport - 2-wire VG - Dedicated - Facility Termination per month			UNCVX	U1TV2	23.95	98.09	53.67	56.31	22.42								

UNBUNDLED NETWORK ELEMENTS - Kentucky															
CATEGORY	RATE ELEMENTS	Interim	Zone	BCS	USOC	RATES (\$)	Svc Order Submitted Elec per LSR	Svc Order Submitted Manually per LSR	Attachment: 2		Exhibit: A				
									Incremental Charge - Manual Svc Order vs. Electronic-1st	Incremental Charge - Manual Svc Order vs. Electronic-Add'l	Incremental Charge - Manual Svc Order vs. Electronic-Disc 1st	Incremental Charge - Manual Svc Order vs. Electronic-Disc Add'l			
						Rec	Nonrecurring		Nonrecurring Disconnect		OSS Rates (\$)				
							First	Add'l	First	Add'l	SOMEc	SOMAN	SOMAN	SOMAN	SOMAN
	Nonrecurring Currently Combined Network Elements Switch -As-Is Charge			UNCVX	UNCCC		8.98	8.98	11.17	11.17					
	<b>EXTENDED 4-WIRE VOICE GRADE EXTENDED LOOP/ 4 WIRE VOICE GRADE INTEROFFICE TRANSPORT</b>														
	4-WireVG Loop in combination - Zone 1		1	UNCVX	UEAL4	29.26	125.22	60.48	59.69	7.84					
	4-WireVG Loop in combination - Zone 2		2	UNCVX	UEAL4	34.25	125.22	60.48	59.69	7.84					
	4-WireVG Loop in combination - Zone 3		3	UNCVX	UEAL4	85.06	125.22	60.48	59.69	7.84					
	Interoffice Transport - 4-wire VG - Dedicated - Per Mile Per Month			UNCVX	1L5XX	0.01									
	Interoffice Transport - 4-wire VG - Dedicated - Facility Termination per month			UNCVX	U1TV4	21.28	98.09	53.67	56.31	22.42					
	Nonrecurring Currently Combined Network Elements Switch -As-Is Charge			UNCVX	UNCCC		8.98	8.98	11.17	11.17					
	<b>EXTENDED DS3 DIGITAL EXTENDED LOOP WITH DEDICATED DS3 INTEROFFICE TRANSPORT</b>														
	DS3 Local Loop in combination - per mile per month			UNC3X	1L5ND	9.25									
	DS3 Local Loop in combination - Facility Termination per month			UNC3X	UE3PX	308.31	237.36	147.69	83.43	32.67					
	Interoffice Transport - Dedicated - DS3 - Per Mile per month			UNC3X	1L5XX	4.09									
	Interoffice Transport - Dedicated - DS3 combination - Facility Termination per month			UNC3X	U1TF3	966.89	350.56	141.58	48.00	23.39					
	Nonrecurring Currently Combined Network Elements Switch -As-Is Charge			UNC3X	UNCCC		8.98	8.98	11.17	11.17					
	<b>EXTENDED STS-1 DIGITAL EXTENDED LOOP WITH DEDICATED STS-1 INTEROFFICE TRANSPORT</b>														
	STS-1 Local Loop in combination - per mile per month			UNCSX	1L5ND	9.25									
	STS-1 Local Loop in combination - Facility Termination per month			UNCSX	UDLS1	320.51	237.36	147.69	83.43	32.67					
	Interoffice Transport - Dedicated - STS-1 combination - per mile per month			UNCSX	1L5XX	4.09									
	Interoffice Transport - Dedicated - STS-1 combination - Facility Termination per month			UNCSX	U1TFS	945.79	350.56	141.58	48.00	23.39					
	Nonrecurring Currently Combined Network Elements Switch -As-Is Charge			UNCSX	UNCCC		8.98	8.98	11.17	11.17					
	<b>EXTENDED 2-WIRE ISDN EXTENDED LOOP WITH DS1 INTEROFFICE TRANSPORT</b>														
	First 2-Wire ISDN Loop in Combination - Zone 1		1	UNCNX	U1L2X	18.44	125.22	60.48	59.69	7.84					
	First 2-Wire ISDN Loop in Combination - Zone 2		2	UNCNX	U1L2X	25.08	125.22	60.48	59.69	7.84					
	First 2-Wire ISDN Loop in Combination - Zone 3		3	UNCNX	U1L2X	42.87	125.22	60.48	59.69	7.84					
	Interoffice Transport - Dedicated - DS1 combination - per mile per month			UNC1X	1L5XX	0.19									
	Interoffice Transport - Dedicated - DS1 combination - Facility Termination per month			UNC1X	U1TF1	79.02	181.24	123.53	56.72	22.32					
	1/0 Channel System in combination - per month			UNC1X	MQ1	113.33	57.26	14.74	1.86	1.67					
	2-wire ISDN COCI (BRITE) - in combination - per month			UNCNX	UC1CA	2.84	6.71	4.84							
	Additional 2-wire ISDN Loop in same DS1Interoffice Transport Combination - Zone 1		1	UNCNX	U1L2X	18.44	125.22	60.48	59.69	7.84					
	Additional 2-wire ISDN Loop in same DS1Interoffice Transport Combination - Zone 2		2	UNCNX	U1L2X	25.08	125.22	60.48	59.69	7.84					
	Additional 2-wire ISDN Loop in same DS1Interoffice Transport Combination - Zone 3		3	UNCNX	U1L2X	42.87	125.22	60.48	59.69	7.84					
	Additional 2-wire ISDN COCI (BRITE) - in combination- per month			UNCNX	UC1CA	2.84	6.71	4.84							
	Nonrecurring Currently Combined Network Elements Switch -As-Is Charge			UNC1X	UNCCC		8.98	8.98	11.17	11.17					
	<b>EXTENDED 4-WIRE DS1 DIGITAL EXTENDED LOOP WITH DEDICATED STS-1 INTEROFFICE TRANSPORT</b>														
	First DS1 Loop Combination - Zone 1		1	UNC1X	USLXX	86.47	210.70	114.60	63.96	17.97					
	First DS1 Loop Combination - Zone 2		2	UNC1X	USLXX	114.10	210.70	114.60	63.96	17.97					
	First DS1 Loop Combination - Zone 3		3	UNC1X	USLXX	297.76	210.70	114.60	63.96	17.97					
	Interoffice Transport - Dedicated - STS-1 combination - Per Mile Per Month			UNCSX	1L5XX	4.09									
	Interoffice Transport - Dedicated - STS-1 combination - Facility Termination per month			UNCSX	U1TFS	945.79	350.56	141.58	48.00	23.39					
	3/1 Channel System in combination per month			UNCSX	MQ3	158.20	115.48	56.53	15.12	5.30					
	DS1 COCI in combination per month			UNC1X	UC1D1	11.80	6.71	4.84							
	Additional DS1Loop in the same STS-1 Interoffice Transport Combination - Zone 1		1	UNC1X	USLXX	86.47	210.70	114.60	63.96	17.97					

UNBUNDLED NETWORK ELEMENTS - Kentucky															
CATEGORY	RATE ELEMENTS	Interim	Zone	BCS	USOC	RATES (\$)	Svc Order Submitted Elec per LSR	Svc Order Submitted Manually per LSR	Attachment: 2		Exhibit: A				
									Incremental Charge - Manual Svc Order vs. Electronic-1st	Incremental Charge - Manual Svc Order vs. Electronic-Add'l	Incremental Charge - Manual Svc Order vs. Electronic-Disc 1st	Incremental Charge - Manual Svc Order vs. Electronic-Disc Add'l			
						Rec	Nonrecurring		Nonrecurring Disconnect		OSS Rates (\$)				
							First	Add'l	First	Add'l	SOMEc	SOMAN	SOMAN	SOMAN	SOMAN
	Additional DS1 Loop in the same STS-1 Interoffice Transport Combination - Zone 2		2	UNC1X	USLXX	114.10	210.70	114.60	63.96	17.97					
	Additional DS1 Loop in the same STS-1 Interoffice Transport Combination - Zone 3		3	UNC1X	USLXX	297.76	210.70	114.60	63.96	17.97					
	DS1 COCI in combination per month			UNC1X	UC1D1	11.80	6.71	4.84							
	Nonrecurring Currently Combined Network Elements Switch -As-Is Charge			UNCSX	UNCCC		8.98	8.98	11.17	11.17					
<b>EXTENDED 4-WIRE 56 KBPS DIGITAL EXTENDED LOOP WITH 56 KBPS INTEROFFICE TRANSPORT</b>															
	4-wire 56 kbps Local Loop in combination - Zone 1		1	UNCDX	UDL56	27.59	125.22	60.48	59.69	7.84					
	4-wire 56 kbps Local Loop in combination - Zone 2		2	UNCDX	UDL56	32.48	125.22	60.48	59.69	7.84					
	4-wire 56 kbps Local Loop in combination - Zone 3		3	UNCDX	UDL56	36.37	125.22	60.48	59.69	7.84					
	Interoffice Transport - Dedicated - 4-wire 56 kbps combination - Per Mile per month			UNCDX	1L5XX	0.01									
	Interoffice Transport - Dedicated - 4-wire 56 kbps combination - Facility Termination per month			UNCDX	U1TD5	17.25	98.09	53.67	56.31	22.42					
	Nonrecurring Currently Combined Network Elements Switch -As-Is Charge			UNCDX	UNCCC		8.98	8.98	11.17	11.17					
<b>EXTENDED 4-WIRE 64 KBPS DIGITAL EXTENDED LOOP WITH 64 KBPS INTEROFFICE TRANSPORT</b>															
	4-wire 64 kbps Local Loop in Combination - Zone 1		1	UNCDX	UDL64	27.59	125.22	60.48	59.69	7.84					
	4-wire 64 kbps Local Loop in Combination - Zone 2		2	UNCDX	UDL64	32.48	125.22	60.48	59.69	7.84					
	4-wire 64 kbps Local Loop in Combination - Zone 3		3	UNCDX	UDL64	36.37	125.22	60.48	59.69	7.84					
	Interoffice Transport - Dedicated - 4-wire 64 kbps combination - Per Mile per month			UNCDX	1L5XX	0.01									
	Interoffice Transport - Dedicated - 4-wire 64 kbps combination - Facility Termination per month			UNCDX	U1TD6	17.25	98.09	53.67	56.31	22.42					
	Nonrecurring Currently Combined Network Elements Switch -As-Is Charge			UNCDX	UNCCC		8.98	8.98	11.17	11.17					
<b>EXTENDED 2-WIRE VOICE GRADE LOOP WITH DS1 INTEROFFICE TRANSPORT w/ 3/1 MUX</b>															
	First 2-wire VG Loop (SL2) in Combination - Zone 1		1	UNCVX	UEAL2	12.67	125.22	60.48	59.69	7.84					
	First 2-wire VG Loop (SL2) in Combination - Zone 2		2	UNCVX	UEAL2	17.45	125.22	60.48	59.69	7.84					
	First 2-wire VG Loop (SL2) in Combination - Zone 3		3	UNCVX	UEAL2	33.22	125.22	60.48	59.69	7.84					
	First Interoffice Transport - Dedicated - DS1 combination - Per Mile			UNC1X	1L5XX	0.19									
	First Interoffice Transport - Dedicated - DS1 combination - Facility Termination per month			UNC1X	U1TF1	79.02	181.24	123.53	56.72	22.32					
	Per each DS1 Channelization System Per Month			UNC1X	MQ1	113.33	57.26	14.74	1.86	1.67					
	Per each Voice Grade COCI - Per Month per month			UNCVX	1D1VG	0.62	6.71	4.84							
	3/1 Channel System in combination per month			UNC3X	MQ3	158.20	115.48	56.53	15.12	5.30					
	Per each DS1 COCI in combination per month			UNC1X	UC1D1	11.80	6.71	4.84							
	Each Additional 2-Wire VG Loop (SL2) in the same DS1 Interoffice Transport Combination - Zone 1		1	UNCVX	UEAL2	12.67	125.22	60.48	59.69	7.84					
	Each Additional 2-Wire VG Loop (SL2) in the same DS1 Interoffice Transport Combination - Zone 2		2	UNCVX	UEAL2	17.45	125.22	60.48	59.69	7.84					
	Each Additional 2-Wire VG Loop (SL2) in the same DS1 Interoffice Transport Combination - Zone 3		3	UNCVX	UEAL2	33.22	125.22	60.48	59.69	7.84					
	Each Additional Voice Grade COCI in combination - per month			UNCVX	1D1VG	0.62	6.71	4.84							
	Each Additional DS1 Interoffice Channel per mile in same 3/1 Channel System per month			UNC1X	1L5XX	0.19									
	Each Additional DS1 Interoffice Channel Facility Termination in same 3/1 Channel System per month			UNC1X	U1TF1	79.02	181.24	123.53	56.72	22.32					
	Each Additional DS1 COCI combination per month			UNC1X	UC1D1	11.80	6.71	4.84							
	Nonrecurring Currently Combined Network Elements Switch -As-Is Charge			UNC1X	UNCCC		8.98	8.98	11.17	11.17					
<b>EXTENDED 4-WIRE VOICE GRADE LOOP WITH DEDICATED DS1 INTEROFFICE TRANSPORT w/ 3/1 MUX</b>															
	First 4-Wire Analog Voice Grade Local Loop in Combination - Zone 1		1	UNCVX	UEAL4	29.26	125.22	60.48	59.69	7.84					
	First 4-Wire Analog Voice Grade Local Loop in Combination - Zone 2		2	UNCVX	UEAL4	34.25	125.22	60.48	59.69	7.84					
	First 4-Wire Analog Voice Grade Local Loop in Combination - Zone 3		3	UNCVX	UEAL4	85.06	125.22	60.48	59.69	7.84					
	First Interoffice Transport - Dedicated - DS1 combination - Per Mile Per Month			UNC1X	1L5XX	0.19									

UNBUNDLED NETWORK ELEMENTS - Kentucky														
CATEGORY	RATE ELEMENTS	Interim	Zone	BCS	USOC	RATES (\$)	Svc Order Submitted Elec per LSR	Svc Order Submitted Manually per LSR	Attachment: 2		Exhibit: A			
									Incremental Charge - Manual Svc Order vs. Electronic-1st	Incremental Charge - Manual Svc Order vs. Electronic-Add'l	Incremental Charge - Manual Svc Order vs. Electronic-Disc 1st	Incremental Charge - Manual Svc Order vs. Electronic-Disc Add'l		
									OSS Rates (\$)				SOME	SOMAN
						Rec	Nonrecurring		Nonrecurring Disconnect					
							First	Add'l	First	Add'l				
	First Interoffice Transport - Dedicated - DS1 - Facility Termination Per Month			UNC1X	U1TF1	79.02	181.24	123.53	56.72	22.32				
	Per each 1/0 Channel System in combination Per Month			UNC1X	MQ1	113.33	57.26	14.74	1.86	1.67				
	Per each Voice Grade COCI in combination - per month			UNCVX	1D1VG	0.62	6.71	4.84						
	3/1 Channel System in combination per month			UNC3X	MQ3	158.20	115.48	56.53	15.12	5.30				
	Per each DS1 COCI in combination per month			UNC1X	UC1D1	11.80	6.71	4.84						
	Additional 4-Wire Analog Voice Grade Loop in same DS1 Interoffice Transport Combination - Zone 1		1	UNCVX	UEAL4	29.26	125.22	60.48	59.69	7.84				
	Additional 4-Wire Analog Voice Grade Loop in same DS1 Interoffice Transport Combination - Zone 2		2	UNCVX	UEAL4	34.25	125.22	60.48	59.69	7.84				
	Additional 4-Wire Analog Voice Grade Loop in same DS1 Interoffice Transport Combination - Zone 3		3	UNCVX	UEAL4	85.06	125.22	60.48	59.69	7.84				
	Each Additional DS1 Interoffice Channel per mile in same 3/1 Channel System per month			UNC1X	1L5XX	0.19								
	Each Additional DS1 Interoffice Channel Facility Termination in same 3/1 Channel System per month			UNC1X	U1TF1	79.02	181.24	123.53	56.72	22.32				
	Additional Voice Grade COCI - in combination - per month			UNCVX	1D1VG	0.62	6.71	4.84						
	Nonrecurring Currently Combined Network Elements Switch -As-Is Charge			UNC1X	UNCCC		8.98	8.98	11.17	11.17				
	<b>EXTENDED 4-WIRE 56 Kbps DIGITAL LOOP WITH DEDICATED DS1 INTEROFFICE TRANSPORT w/ 3/1 MUX</b>													
	First 4-Wire 56Kbps Digital Grade Local Loop in Combination - Zone 1		1	UNCDX	UDL56	27.59	125.22	60.48	59.69	7.84				
	First 4-Wire 56Kbps Digital Grade Local Loop in Combination - Zone 2		2	UNCDX	UDL56	32.48	125.22	60.48	59.69	7.84				
	First 4-Wire 56Kbps Digital Grade Local Loop in Combination - Zone 3		3	UNCDX	UDL56	36.37	125.22	60.48	59.69	7.84				
	First Interoffice Transport - Dedicated - DS1 combination - Per Mile Per Month			UNC1X	1L5XX	0.19								
	First Interoffice Transport - Dedicated - DS1 - combination Facility Termination Per Month			UNC1X	U1TF1	79.02	181.24	123.53	56.72	22.32				
	Per each 1/0 Channel System in combination Per Month			UNC1X	MQ1	113.33	57.26	14.74	1.86	1.67				
	Per each OCU-DP COCI (data) COCI per month (2.4-64kbs)			UNCDX	1D1DD	1.32	6.71	4.84						
	3/1 Channel System in combination per month			UNC3X	MQ3	158.20	115.48	56.53	15.12	5.30				
	Per each DS1 COCI in combination per month			UNC1X	UC1D1	11.80	6.71	4.84						
	Additional 4-Wire 56Kbps Digital Grade Loop in same DS1 Interoffice Transport Combination - Zone 1		1	UNCDX	UDL56	27.59	125.22	60.48	59.69	7.84				
	Additional 4-Wire 56Kbps Digital Grade Loop in same DS1 Interoffice Transport Combination - Zone 2		2	UNCDX	UDL56	32.48	125.22	60.48	59.69	7.84				
	Additional 4-Wire 56Kbps Digital Grade Loop in same DS1 Interoffice Transport Combination - Zone 3		3	UNCDX	UDL56	36.37	125.22	60.48	59.69	7.84				
	OCU-DP COCI (data) COCI in combination per month (2.4-64kbs)			UNCDX	1D1DD	1.32	6.71	4.84						
	Each Additional DS1 Interoffice Channel per mile in same 3/1 Channel System per month			UNC1X	1L5XX	0.19								
	Each Additional DS1 Interoffice Channel Facility Termination in same 3/1 Channel System per month			UNC1X	U1TF1	79.02	181.24	123.53	56.72	22.32				
	Each Additional DS1 COCI in the same 3/1 channel system combination per month			UNC1X	UC1D1	11.80	6.71	4.84						
	Nonrecurring Currently Combined Network Elements Switch -As-Is Charge			UNC1X	UNCCC		8.98	8.98	11.17	11.17				
	<b>EXTENDED 4-WIRE 64 Kbps DIGITAL LOOP WITH DEDICATED DS1 INTEROFFICE TRANSPORT w/ 3/1 MUX</b>													
	First 4-Wire 64Kbps Digital Grade Loop in a DS1 Interoffice Transport Combination - Zone 1		1	UNCDX	UDL64	27.59	125.22	60.48	59.69	7.84				
	First 4-Wire 64Kbps Digital Grade Loop in a DS1 Interoffice Transport Combination - Zone 2		2	UNCDX	UDL64	32.48	125.22	60.48	59.69	7.84				
	First 4-Wire 64Kbps Digital Grade Loop in a DS1 Interoffice Transport Combination - Zone 3		3	UNCDX	UDL64	36.37	125.22	60.48	59.69	7.84				
	First Interoffice Transport - Dedicated - DS1 combination - Per Mile Per Month			UNC1X	1L5XX	0.19								
	First Interoffice Transport - Dedicated - DS1 combination - Facility Termination Per Month			UNC1X	U1TF1	79.02	181.24	123.53	56.72	22.32				
	Per each Channel System 1/0 in combination Per Month			UNC1X	MQ1	113.33	57.26	14.74	1.86	1.67				

UNBUNDLED NETWORK ELEMENTS - Kentucky														Attachment: 2		Exhibit: A					
CATEGORY	RATE ELEMENTS	Interim	Zone	BCS	USOC	RATES (\$)	Svc Order Submitted Elec per LSR	Svc Order Submitted Manually per LSR	Incremental Charge - Manual Svc Order vs. Electronic-1st	Incremental Charge - Manual Svc Order vs. Electronic-Add'l	Incremental Charge - Manual Svc Order vs. Electronic-Disc 1st	Incremental Charge - Manual Svc Order vs. Electronic-Disc Add'l	OSS Rates (\$)								
													Rec	Nonrecurring		Nonrecurring Disconnect		SOME	SOMAN	SOMAN	SOMAN
													First	Add'l	First	Add'l					
	Per each OCU-DP COCI (data) in combination - per month (2.4-64kbs)			UNCDX	1D1DD	1.32															
	3/1 Channel System in combination per month			UNC3X	MQ3	158.20															
	Additional 4-Wire 64Kbps Digital Grade Loop in same DS1 Interoffice Transport Combination - Zone 1		1	UNCDX	UDL64	27.59															
	Additional 4-Wire 64Kbps Digital Grade Loop in same DS1 Interoffice Transport Combination - Zone 2		2	UNCDX	UDL64	32.48															
	Additional 4-Wire 64Kbps Digital Grade Loop in same DS1 Interoffice Transport Combination - Zone 3		3	UNCDX	UDL64	36.37															
	Additional OCU-DP COCI (data) - DS1 to DS0 Channel System combination - per month (2.4-64kbs)			UNCDX	1D1DD	1.32															
	Each Additional DS1 Interoffice Channel per mile in same 3/1 Channel System per month			UNC1X	1L5XX	0.19															
	Each Additional DS1 Interoffice Channel Facility Termination in same 3/1 Channel System per month			UNC1X	U1TF1	79.02															
	Each Additional DS1 COCI in the same 3/1 channel system combination per month			UNC1X	UC1D1	11.80															
	Nonrecurring Currently Combined Network Elements Switch -As-Is Charge			UNC1X	UNCCC																
	<b>EXTENDED 2-WIRE ISDN LOOP WITH DS1 INTEROFFICE TRANSPORT w/ 3/1 MUX</b>																				
	First 2-Wire ISDN Loop in a DS1 Interoffice Combination Transport - Zone 1		1	UNCNX	U1L2X	18.44															
	First 2-Wire ISDN Loop in a DS1 Interoffice Combination Transport - Zone 2		2	UNCNX	U1L2X	25.08															
	First 2-Wire ISDN Loop in a DS1 Interoffice Combination Transport - Zone 3		3	UNCNX	U1L2X	42.87															
	First Interoffice Transport - Dedicated - DS1 combination - Per Mile per month			UNC1X	1L5XX	0.19															
	First Interoffice Transport - Dedicated - DS1 combination - Facility Termination per month			UNC1X	U1TF1	79.02															
	Per each Channel System 1/0 in combination - per month			UNC1X	MQ1	113.33															
	Per each 2-wire ISDN COCI (BRITE) in combination - per month			UNCNX	UC1CA	2.84															
	3/1 Channel System in combination per month			UNC3X	MQ3	158.20															
	Per each DS1 COCI in combination per month			UNC1X	UC1D1	11.80															
	Additional 2-wire ISDN Loop in same DS1 Interoffice Transport Combination - Zone 1		1	UNCNX	U1L2X	18.44															
	Additional 2-wire ISDN Loop in same DS1 Interoffice Transport Combination - Zone 2		2	UNCNX	U1L2X	25.08															
	Additional 2-wire ISDN Loop in same DS1 Interoffice Transport Combination - Zone 3		3	UNCNX	U1L2X	42.87															
	Additional 2-wire ISDN COCI (BRITE) in same 1/0 channel system combination- per month			UNCNX	UC1CA	2.84															
	Each Additional DS1 Interoffice Channel per mile in same 3/1 Channel System per month			UNC1X	1L5XX	0.19															
	Each Additional DS1 Interoffice Channel Facility Termination in same 3/1 Channel System per month			UNC1X	U1TF1	79.02															
	Each Additional DS1 COCI in the same 3/1 channel system combination per month			UNC1X	UC1D1	11.80															
	Nonrecurring Currently Combined Network Elements Switch -As-Is Charge			UNC1X	UNCCC																
	<b>EXTENDED 4-WIRE DS1 LOOP WITH DEDICATED DS1 INTEROFFICE TRANSPORT w/ 3/1 MUX</b>																				
	First 4-wire DS1 Digital Local Loop in Combination - Zone 1		1	UNC1X	USLXX	86.47															
	First 4-wire DS1 Digital Local Loop in Combination - Zone 2		2	UNC1X	USLXX	114.10															
	First 4-wire DS1 Digital Local Loop in Combination - Zone 3		3	UNC1X	USLXX	297.76															
	First Interoffice Transport - Dedicated - DS1 combination - Per Mile Per Month			UNC1X	1L5XX	0.19															
	First Interoffice Transport - Dedicated - DS1 combination - Facility Termination Per Month			UNC1X	U1TF1	79.02															
	3/1 Channel System in combination per month			UNC3X	MQ3	158.20															
	Per each DS1 COCI combination per month			UNC1X	UC1D1	11.80															
	Each Additional DS1 Interoffice Channel per mile in same 3/1 Channel System per month			UNC1X	1L5XX	0.19															

UNBUNDLED NETWORK ELEMENTS - Kentucky											Attachment: 2		Exhibit: A					
CATEGORY	RATE ELEMENTS	Interim	Zone	BCS	USOC	RATES (\$)	Svc Order Submitted Elec per LSR	Svc Order Submitted Manually per LSR	Incremental Charge - Manual Svc Order vs. Electronic-1st	Incremental Charge - Manual Svc Order vs. Electronic-Add'l	Incremental Charge - Manual Svc Order vs. Electronic-Disc 1st	Incremental Charge - Manual Svc Order vs. Electronic-Disc Add'l	OSS Rates (\$)					
													Rec	Nonrecurring		Nonrecurring Disconnect		SOME
	Each Additional DS1 Interoffice Channel Facility Termination in same 3/1 Channel System per month			UNC1X	U1TF1	79.02		181.24	123.53	56.72	22.32							
	Each Additional DS1 COCI in the same 3/1 channel system combination per month			UNC1X	UC1D1	11.80		6.71	4.84									
	Additional 4-Wire DS1 Digital Local Loop in Combination - Zone 1		1	UNC1X	USLXX	86.47		210.70	114.60	63.96	17.97							
	Additional 4-Wire DS1 Digital Local Loop in Combination - Zone 2		2	UNC1X	USLXX	114.10		210.70	114.60	63.96	17.97							
	Additional 4-Wire DS1 Digital Local Loop in Combination - Zone 3		3	UNC1X	USLXX	297.76		210.70	114.60	63.96	17.97							
	Nonrecurring Currently Combined Network Elements Switch -As-Is Charge			UNC1X	UNCCC			8.98	8.98	11.17	11.17							
<b>EXTENDED 4-WIRE 56 KBPS DIGITAL EXTENDED LOOP WITH DS0 INTEROFFICE TRANSPORT</b>																		
	First 4-wire 56 kbps Local Loop in combination - Zone 1		1	UNCDX	UDL56	27.59		125.22	60.48	59.69	7.84							
	First 4-wire 56 kbps Local Loop in combination - Zone 2		2	UNCDX	UDL56	32.48		125.22	60.48	59.69	7.84							
	First 4-wire 56 kbps Local Loop in combination - Zone 3		3	UNCDX	UDL56	36.37		125.22	60.48	59.69	7.84							
	First 4-wire 56 kbps Interoffice Transport - Dedicated - Per Mile per month			UNCDX	1L5XX	0.01												
	First 4-wire 56 kbps Interoffice Transport - Dedicated - Facility Termination per month			UNCDX	U1TD5	17.25		98.09	53.67	56.31	22.42							
	Nonrecurring Currently Combined Network Elements Switch -As-Is Charge			UNCDX	UNCCC			8.98	8.98	11.17	11.17							
<b>EXTENDED 4-WIRE 64 KBPS DIGITAL EXTENDED LOOP WITH DS0 INTEROFFICE TRANSPORT</b>																		
	First 4-wire 64 kbps Local Loop in combination - Zone 1		1	UNCDX	UDL64	27.59		125.22	60.48	59.69	7.84							
	First 4-wire 64 kbps Local Loop in combination - Zone 2		2	UNCDX	UDL64	32.48		125.22	60.48	59.69	7.84							
	First 4-wire 64 kbps Local Loop in combination - Zone 3		3	UNCDX	UDL64	36.37		125.22	60.48	59.69	7.84							
	First 4-wire 65 kbps Interoffice Transport - Dedicated - Per Mile per month			UNCDX	1L5XX	0.01												
	First 4-wire 64 kbps Interoffice Transport - Dedicated - Facility Termination per month			UNCDX	U1TD6	17.25		98.09	53.67	56.31	22.42							
	Nonrecurring Currently Combined Network Elements Switch -As-Is Charge			UNCDX	UNCCC			8.98	8.98	11.17	11.17							
<b>ADDITIONAL NETWORK ELEMENTS</b>																		
When used as a part of a currently combined facility, the non-recurring charges do not apply, but a Switch As Is charge does apply.																		
When used as ordinarily combined network elements in All States, the non-recurring charges apply and the Switch As Is Charge does not.																		
<b>Nonrecurring Currently Combined Network Elements "Switch As Is" Charge (One applies to each combination)</b>																		
	Nonrecurring Currently Combined Network Elements Switch -As-Is Charge - 2 wire/4-Wire VG			UNCVX	UNCCC			8.98	8.98	11.17	11.17							
	Nonrecurring Currently Combined Network Elements Switch -As-Is Charge - 56/64 kbps			UNCDX	UNCCC			8.98	8.98	11.17	11.17							
	Nonrecurring Currently Combined Network Elements Switch -As-Is Charge - DS1			UNC1X	UNCCC			8.98	8.98	11.17	11.17							
	Nonrecurring Currently Combined Network Elements Switch -As-Is Charge - DS3			UNC3X	UNCCC			8.98	8.98	11.17	11.17							
	Nonrecurring Currently Combined Network Elements Switch -As-Is Charge - STS1			UNCSX	UNCCC			8.98	8.98	11.17	11.17							
<b>Optional Features &amp; Functions:</b>																		
	Clear Channel Capability Extended Frame Option - per DS1			U1TD1, ULDD1, UNC1X	CCOEF			0I	0I	0I	0I							
	Clear Channel Capability Super FrameOption - per DS1			U1TD1, ULDD1, UNC1X	CCOSF			0I	0I	0I	0I							
	Clear Channel Capability (SF/ESF) Option - Subsequent Activity - per DS1			ULDD1, U1TD1, UNC1X, USL	NRCCC			184.91S	23.82S	1.99S	0.78S							
	C-bit Parity Option - Subsequent Activity - per DS3			U1TD3, ULDD3, UE3, UNC3X	NRCC3			205.70S	7.20S	.6924S	0S							
<b>MULTIPLEXERS</b>																		
	DS1 to DS0 Channel System per month			UNC1X	MQ1	113.33		57.26	14.74	1.86	1.67							
	OCU-DP COCI (data) - DS1 to DS0 Channel System - per month (2.4-64kbs) used for a Local Loop			UDL	1D1DD	1.32		10.07	7.08									
	OCU-DP COCI (data) - DS1 to DS0 Channel System - per month (2.4-64kbs) used for connection to a channelized DS1 Local Channel in the same SWC as collocation			U1TUD	1D1DD	1.32		10.07	7.08									

UNBUNDLED NETWORK ELEMENTS - Kentucky														Attachment: 2		Exhibit: A	
CATEGORY	RATE ELEMENTS	Interim	Zone	BCS	USOC	RATES (\$)				Svc Order Submitted Elec per LSR	Svc Order Submitted Manually per LSR	Incremental Charge - Manual Svc Order vs. Electronic-1st	Incremental Charge - Manual Svc Order vs. Electronic-Add'l	Incremental Charge - Manual Svc Order vs. Electronic-Disc 1st	Incremental Charge - Manual Svc Order vs. Electronic-Disc Add'l		
						Rec	Nonrecurring		Nonrecurring Disconnect							OSS Rates (\$)	
							First	Add'l	First	Add'l	SOME	SOMAN	SOMAN	SOMAN	SOMAN		
	2-wire ISDN COCI (BRITE) - DS1 to DS0 Channel System - per month for a Local Loop			UDN	UC1CA	2.84	10.07	7.08									
	2-wire ISDN COCI (BRITE) - DS1 to DS0 Channel System - per month used for connection to a channelized DS1 Local Channel in the same SWC as collocation			U1TUB	UC1CA	2.84	10.07	7.08									
	Voice Grade COCI - DS1 to DS0 Channel System - per month used for a Local Loop			UEA	1D1VG	0.6228	10.07	7.08									
	Voice Grade COCI - DS1 to DS0 Channel System - per month used for connection to a channelized DS1 Local Channel in the same SWC as collocation			U1TUC	1D1VG	0.6228	10.07	7.08									
	DS3 to DS1 Channel System per month			UNC3X	MQ3	158.20	115.48	56.53	15.12	5.30							
	STS-1 to DS1 Channel System per month			UNC5X	MQ3	158.20	115.48	56.53	15.12	5.30							
	DS1 COCI used with Loop per month			USL	UC1D1	11.80	10.07	7.08									
	DS1 COCI (used for connection to a channelized DS1 Local Channel in the same SWC as collocation) per month			U1TUA	UC1D1	11.80	10.07	7.08									
	DS1 COCI used with Interoffice Channel per month			U1TD1	UC1D1	11.80	10.07	7.08									
	DS3 Interface Unit (DS1 COCI) used with Local Channel per month			ULDD1	UC1D1	11.80	10.07	7.08									
<b>UNBUNDLED LOCAL EXCHANGE SWITCHING(PORTS)</b>																	
Exchange Ports																	
<b>NOTE: Although the Port Rate includes all available features in GA, KY, LA &amp; TN, the desired features will need to be ordered using retail USOCs</b>																	
<b>2-WIRE VOICE GRADE LINE PORT RATES (RES)</b>																	
	Exchange Ports - 2-Wire Analog Line Port- Res.			UEPSR	UEPRL	1.49	3.74	3.63	2.23	2.13							
	Exchange Ports - 2-Wire Analog Line Port with Caller ID - Res.			UEPSR	UEPRC	1.49	3.74	3.63	2.23	2.13							
	Exchange Ports - 2-Wire Analog Line Port outgoing only - Res.			UEPSR	UEPRO	1.49	3.74	3.63	2.23	2.13							
	Exchange Ports - 2-Wire VG unbundled KY extended local dialing parity Port with Caller ID - Res.			UEPSR	UEPRM	1.49	3.74	3.63	2.23	2.13							
	Exchange Ports - 2-Wire VG unbundled res, low usage line port with Caller ID (LUM)			UEPSR	UEPAP	1.49	3.74	3.63	2.23	2.13							
	Exchange Ports - 2-Wire Voice Kentucky Residence Dialing Plan without Caller ID			UEPSR	UEPWE	1.49	3.74	3.63	2.23	2.13							
	2-Wire voice unbundled Low Usage Line Port without Caller ID Capability			UEPSR	UEPRT	1.49	3.74	3.63	2.23	2.13							
	Subsequent Activity			UEPSR	USASC	0.00	0.00	0.00									
<b>FEATURES</b>																	
	All Available Vertical Features			UEPSR	UEPVF	0.00	0.00	0.00									
<b>2-WIRE VOICE GRADE LINE PORT RATES (BUS)</b>																	
	Exchange Ports - 2-Wire Analog Line Port without Caller ID - Bus			UEPSB	UEPBL	1.49	3.74	3.63	2.23	2.13							
	Exchange Ports - 2-Wire VG unbundled Line Port with unbundled port with Caller+E484 ID - Bus.			UEPSB	UEPBC	1.49	3.74	3.63	2.23	2.13							
	Exchange Ports - 2-Wire Analog Line Port outgoing only - Bus.			UEPSB	UEPBO	1.49	3.74	3.63	2.23	2.13							
	Exchange Ports - 2-Wire VG unbundled KY extended local dialing parity Port with Caller ID - Bus.			UEPSB	UEPBM	1.49	3.74	3.63	2.23	2.13							
	Exchange Ports - 2-Wire VG unbundled incoming only port with Caller ID - Bus			UEPSB	UEPB1	1.49	3.74	3.63	2.23	2.13							
	Exchange Ports - 2-Wire Voice Kentucky Business Dialing Plan without Caller ID			UEPSB	UEPWF	1.49	3.74	3.63	2.23	2.13							
	2-Wire voice unbundled Incoming Only Port without Caller ID Capability			UEPSB	UEPBE	1.49	3.74	3.63	2.23	2.13							
	Subsequent Activity			UEPSB	USASC	0.00	0.00	0.00									
<b>FEATURES</b>																	
	All Available Vertical Features			UEPSB	UEPVF	0.00	0.00	0.00									
<b>EXCHANGE PORT RATES (DID &amp; PBX)</b>																	
	2-Wire VG Unbundled 2-Way PBX Trunk - Res			UEPSE	UEPRD	1.49	39.05	18.17	15.38	0.89							
	2-Wire VG Line Side Unbundled 2-Way PBX Trunk - Bus			UEPSP	UEPPC	1.49	39.05	18.17	15.38	0.89							
	2-Wire VG Line Side Unbundled Outward PBX Trunk - Bus			UEPSP	UEPPO	1.49	39.05	18.17	15.38	0.89							
	2-Wire VG Line Side Unbundled Incoming PBX Trunk - Bus			UEPSP	UEPP1	1.49	39.05	18.17	15.38	0.89							
	2-Wire Analog Long Distance Terminal PBX Trunk - Bus			UEPSP	UEPLD	1.49	39.05	18.17	15.38	0.89							
	2-Wire Voice Unbundled PBX LD Terminal Ports			UEPSP	UEPLD	1.49	39.05	18.17	15.38	0.89							
	2-Wire Vce Unbundled 2-Way PBX Usage Port			UEPSP	UEPXA	1.49	39.05	18.17	15.38	0.89							
	2-Wire Voice Unbundled PBX Toll Terminal Hotel Ports			UEPSP	UEPXB	1.49	39.05	18.17	15.38	0.89							







UNBUNDLED NETWORK ELEMENTS - Kentucky											Attachment: 2		Exhibit: A							
CATEGORY	RATE ELEMENTS	Interim	Zone	BCS	USOC	RATES (\$)	Svc Order Submitted Elec per LSR	Svc Order Submitted Manually per LSR	Incremental Charge - Manual Svc Order vs. Electronic-1st	Incremental Charge - Manual Svc Order vs. Electronic-Add'l	Incremental Charge - Manual Svc Order vs. Electronic-Disc 1st	Incremental Charge - Manual Svc Order vs. Electronic-Disc Add'l	OSS Rates (\$)							
													Rec	Nonrecurring		Nonrecurring Disconnect		SOMEc	SOMAN	SOMAN
													First	Add'l	First	Add'l				
	2-Wire voice unbundled port with Caller ID - res			UEPRX	UEPRC	1.15							21.29	15.49	2.85	2.67				
	2-Wire voice unbundled port outgoing only - res			UEPRX	UEPRO	1.15							21.29	15.49	2.85	2.67				
	2-Wire voice Grade unbundled Kentucky extended local dialing parity port with Caller ID - res			UEPRX	UEPRM	1.15							21.29	15.49	2.85	2.67				
	2-Wire voice unbundles res, low usage line port with Caller ID (LUM)			UEPRX	UEPAP	1.15							21.29	15.49	2.85	2.67				
	2-Wire Voice Unbundled Kentucky Residence Dialing Plan without Caller ID			UEPRX	UEPWE	1.15							21.29	15.49	2.85	2.67				
	2-Wire voice unbundled Low Usage Line Port without Caller ID Capability			UEPRX	UEPRT	1.15							21.29	15.49	2.85	2.67				
	<b>FEATURES</b>																			
	All Features Offered			UEPRX	UEPVF	0.00							0.00	0.00						
	<b>LOCAL NUMBER PORTABILITY</b>																			
	Local Number Portability (1 per port)			UEPRX	LNPCX	0.35														
	<b>NONRECURRING CHARGES (NRCs) - CURRENTLY COMBINED</b>																			
	2-Wire Voice Grade Loop / Line Port Combination - Conversion - Switch-as-is			UEPRX	USAC2								0.10	0.10						
	2-Wire Voice Grade Loop / Line Port Combination - Conversion - Switch with change			UEPRX	USACC								0.10	0.10						
	<b>ADDITIONAL NRCs</b>																			
	2-Wire Voice Grade Loop/Line Port Combination - Subsequent Activity			UEPRX	USAS2	0.00							0.00	0.00						
	Unbundled Miscellaneous Rate Element, Tag Loop at End User Premise			UEPRX	URETL									8.33	0.83					
	<b>OFF/ON PREMISES EXTENSION CHANNELS</b>																			
	2 Wire Analog Voice Grade Extension Loop - Non-Design		1	UEPRX	UEAEN	10.56							46.66	22.57	26.65	7.65				
	2 Wire Analog Voice Grade Extension Loop - Non-Design		2	UEPRX	UEAEN	15.34							46.66	22.57	26.65	7.65				
	2 Wire Analog Voice Grade Extension Loop - Non-Design		3	UEPRX	UEAEN	31.11							46.66	22.57	26.65	7.65				
	2 Wire Analog Voice Grade Extension Loop - Design		1	UEPRX	UEAED	12.67							134.89	81.87	73.65	14.88				
	2 Wire Analog Voice Grade Extension Loop - Design		2	UEPRX	UEAED	17.45							134.89	81.87	73.65	14.88				
	2 Wire Analog Voice Grade Extension Loop - Design		3	UEPRX	UEAED	33.22							134.89	81.87	73.65	14.88				
	<b>INTEROFFICE TRANSPORT</b>																			
	Interoffice Transport - Dedicated - 2 Wire Voice Grade - Facility Termination			UEPRX	U1TV2	23.95							98.09	53.67	56.31	22.42				
	Interoffice Transport - Dedicated - 2 Wire Voice Grade - Per Mile or Fraction Mile			UEPRX	U1TVM	0.0095							0.00	0.00						
	<b>2-WIRE VOICE GRADE LOOP WITH 2-WIRE LINE PORT (BUS)</b>																			
	<b>UNE Port/Loop Combination Rates</b>																			
	2-Wire VG Loop/Port Combo - Zone 1		1			10.79														
	2-Wire VG Loop/Port Combo - Zone 2		2			15.52														
	2-Wire VG Loop/Port Combo - Zone 3		3			31.74														
	<b>UNE Loop Rates</b>																			
	2-Wire Voice Grade Loop (SL1) - Zone 1		1	UEPBX	UEPLX	9.64														
	2-Wire Voice Grade Loop (SL1) - Zone 2		2	UEPBX	UEPLX	14.37														
	2-Wire Voice Grade Loop (SL1) - Zone 3		3	UEPBX	UEPLX	30.59														
	<b>2-Wire Voice Grade Line Port (Bus)</b>																			
	2-Wire voice unbundled port without Caller ID - bus			UEPBX	UEPBL	1.15							21.29	15.49	2.85	2.67				
	2-Wire voice unbundled port with Caller + E484 ID - bus			UEPBX	UEPBC	1.15							21.29	15.49	2.85	2.67				
	2-Wire voice unbundled port outgoing only - bus			UEPBX	UEPBO	1.15							21.29	15.49	2.85	2.67				
	2-Wire voice Grade unbundled Kentucky extended local dialing parity port with Caller ID - bus			UEPBX	UEPBM	1.15							21.29	15.49	2.85	2.67				
	2-Wire voice unbundled incoming only port with Caller ID - Bus			UEPBX	UEPB1	1.15							21.29	15.49	2.85	2.67				
	2-Wire Voice Unbundled Kentucky Business Dialing Plan without Caller ID			UEPBX	UEPWF	1.15							21.29	15.49	2.85	2.67				
	2-Wire voice unbundled Incoming Only Port without Caller ID Capability			UEPBX	UEPBE	1.15							21.29	15.49	2.85	2.67				
	<b>LOCAL NUMBER PORTABILITY</b>																			
	Local Number Portability (1 per port)			UEPBX	LNPCX	0.35														
	<b>FEATURES</b>																			
	All Features Offered			UEPBX	UEPVF	0.00							0.00	0.00						
	<b>NONRECURRING CHARGES (NRCs) - CURRENTLY COMBINED</b>																			

UNBUNDLED NETWORK ELEMENTS - Kentucky															
CATEGORY	RATE ELEMENTS	Interim	Zone	BCS	USOC	RATES (\$)	Svc Order Submitted Elec per LSR	Svc Order Submitted Manually per LSR	Attachment: 2		Exhibit: A				
									Incremental Charge - Manual Svc Order vs. Electronic-1st	Incremental Charge - Manual Svc Order vs. Electronic-Add'l	Incremental Charge - Manual Svc Order vs. Electronic-Disc 1st	Incremental Charge - Manual Svc Order vs. Electronic-Disc Add'l			
									Rec	Nonrecurring		Nonrecurring Disconnect		OSS Rates (\$)	
						First	Add'l	First	Add'l	SOME C	SOMAN	SOMAN	SOMAN	SOMAN	SOMAN
	2-Wire Voice Grade Loop / Line Port Combination - Conversion - Switch-as-is			UEPBX	USAC2	0.10	0.10								
	2-Wire Voice Grade Loop / Line Port Combination - Conversion - Switch with change			UEPBX	USACC	0.10	0.10								
	<b>ADDITIONAL NRCs</b>														
	2-Wire Voice Grade Loop/Line Port Combination - Subsequent Activity			UEPBX	USAS2	0.00	0.00								
	Unbundled Miscellaneous Rate Element, Tag Loop at End User Premise			UEPBX	URETL	8.33	0.83								
	<b>OFF/ON PREMISES EXTENSION CHANNELS</b>														
	2 Wire Analog Voice Grade Extension Loop - Non-Design		1	UEPBX	UEAEN	10.56	46.66	22.57	26.65	7.65					
	2 Wire Analog Voice Grade Extension Loop - Non-Design		2	UEPBX	UEAEN	15.34	46.66	22.57	26.65	7.65					
	2 Wire Analog Voice Grade Extension Loop - Non-Design		3	UEPBX	UEAEN	31.11	46.66	22.57	26.65	7.65					
	2 Wire Analog Voice Grade Extension Loop - Design		1	UEPBX	UEAED	12.67	134.89	81.87	73.65	14.88					
	2 Wire Analog Voice Grade Extension Loop - Design		2	UEPBX	UEAED	17.45	134.89	81.87	73.65	14.88					
	2 Wire Analog Voice Grade Extension Loop - Design		3	UEPBX	UEAED	33.22	134.89	81.87	73.65	14.88					
	<b>INTEROFFICE TRANSPORT</b>														
	Interoffice Transport - Dedicated - 2 Wire Voice Grade - Facility Termination			UEPBX	U1TV2	23.95	98.09	53.67	56.31	22.42					
	Interoffice Transport - Dedicated - 2 Wire Voice Grade - Per Mile or Fraction Mile			UEPBX	U1TVM	0.0095	0.00	0.00							
	<b>2-WIRE VOICE GRADE LOOP WITH 2-WIRE LINE PORT (RES - PBX)</b>														
	<b>UNE Port/Loop Combination Rates</b>														
	2-Wire VG Loop/Port Combo - Zone 1		1			10.79									
	2-Wire VG Loop/Port Combo - Zone 2		2			15.52									
	2-Wire VG Loop/Port Combo - Zone 3		3			31.74									
	<b>UNE Loop Rates</b>														
	2-Wire Voice Grade Loop (SL 1) - Zone 1		1	UEPRG	UEPLX	9.64									
	2-Wire Voice Grade Loop (SL 1) - Zone 2		2	UEPRG	UEPLX	14.37									
	2-Wire Voice Grade Loop (SL 1) - Zone 3		3	UEPRG	UEPLX	30.59									
	<b>2-Wire Voice Grade Line Port Rates (RES - PBX)</b>														
	2-Wire VG Unbundled Combination 2-Way PBX Trunk Port - Res			UEPRG	UEPRD	1.15	21.29	15.49	2.85	2.67					
	<b>LOCAL NUMBER PORTABILITY</b>														
	Local Number Portability (1 per port)			UEPRG	LNPCP	3.15	0.00	0.00							
	<b>FEATURES</b>														
	All Features Offered			UEPRG	UEPVF	0.00	0.00	0.00							
	<b>NONRECURRING CHARGES (NRCs) - CURRENTLY COMBINED</b>														
	2-Wire Voice Grade Loop/ Line Port Combination (PBX) - Conversion - Switch-As-Is			UEPRG	USAC2	8.45	1.91								
	2-Wire Voice Grade Loop/ Line Port Combination (PBX) - Conversion - Switch with Change			UEPRG	USACC	8.45	1.91								
	<b>ADDITIONAL NRCs</b>														
	2-Wire Voice Grade Loop/ Line Port Combination (PBX) - Subsequent Activity			UEPRG	USAS2	0.00	0.00	0.00							
	PBX Subsequent Activity - Change/Rearrange Multiline Hunt Group					7.86	7.86								
	Unbundled Miscellaneous Rate Element, Tag Loop at End User Premise			UEPRG	URETL	8.33	0.83								
	<b>OFF/ON PREMISES EXTENSION CHANNELS</b>														
	Local Channel Voice grade, per termination		1	UEPRG	P2JHX	12.67	134.89	81.87	73.65	14.88					
	Local Channel Voice grade, per termination		2	UEPRG	P2JHX	17.45	134.89	81.87	73.65	14.88					
	Local Channel Voice grade, per termination		3	UEPRG	P2JHX	33.22	134.89	81.87	73.65	14.88					
	Non-Wire Direct Serve Channel Voice Grade		1	UEPRG	SDD2X	12.68	170.06	78.10	119.62	15.80					
	Non-Wire Direct Serve Channel Voice Grade		2	UEPRG	SDD2X	18.12	170.06	78.10	119.62	15.80					
	Non-Wire Direct Serve Channel Voice Grade		3	UEPRG	SDD2X	29.64	170.06	78.10	119.62	15.80					
	<b>INTEROFFICE TRANSPORT</b>														
	Interoffice Transport - Dedicated - 2 Wire Voice Grade - Facility Termination			UEPRG	U1TV2	23.95	98.09	53.67	56.31	22.42					
	Interoffice Transport - Dedicated - 2 Wire Voice Grade - Per Mile or Fraction Mile			UEPRG	U1TVM	0.0095	0.00	0.00							
	<b>2-WIRE VOICE GRADE LOOP WITH 2-WIRE LINE PORT (BUS - PBX)</b>														

UNBUNDLED NETWORK ELEMENTS - Kentucky															
CATEGORY	RATE ELEMENTS	Interim	Zone	BCS	USOC	RATES (\$)	Svc Order Submitted Elec per LSR	Svc Order Submitted Manually per LSR	Attachment: 2		Exhibit: A				
									Incremental Charge - Manual Svc Order vs. Electronic-1st	Incremental Charge - Manual Svc Order vs. Electronic-Add'l	Incremental Charge - Manual Svc Order vs. Electronic-Disc 1st	Incremental Charge - Manual Svc Order vs. Electronic-Disc Add'l			
									Rec	Nonrecurring		Nonrecurring Disconnect		OSS Rates (\$)	
						First	Add'l	First	Add'l	SOME	SOMAN	SOMAN	SOMAN	SOMAN	SOMAN
<b>UNE Port/Loop Combination Rates</b>															
	2-Wire VG Loop/Port Combo - Zone 1		1			10.79									
	2-Wire VG Loop/Port Combo - Zone 2		2			15.52									
	2-Wire VG Loop/Port Combo - Zone 3		3			31.74									
<b>UNE Loop Rates</b>															
	2-Wire Voice Grade Loop (SL 1) - Zone 1		1	UEPPX	UEPLX	9.64									
	2-Wire Voice Grade Loop (SL 1) - Zone 2		2	UEPPX	UEPLX	14.37									
	2-Wire Voice Grade Loop (SL 1) - Zone 3		3	UEPPX	UEPLX	30.59									
<b>2-Wire Voice Grade Line Port Rates (BUS - PBX)</b>															
	Line Side Unbundled Combination 2-Way PBX Trunk Port - Bus			UEPPX	UEPPC	1.15	21.29	15.49	2.85	2.67					
	Line Side Unbundled Outward PBX Trunk Port - Bus			UEPPX	UEPPO	1.15	21.29	15.49	2.85	2.67					
	Line Side Unbundled Incoming PBX Trunk Port - Bus			UEPPX	UEPP1	1.15	21.29	15.49	2.85	2.67					
	2-Wire Voice Unbundled OutDial Alabama NAR Area Calling Port			UEPPX	UEPOA										
	2-Wire Voice Unbundled PBX LD Terminal Ports			UEPPX	UEPLD	1.15	21.29	15.49	2.85	2.67					
	2-Wire Voice Unbundled 2-Way Combination PBX Usage Port			UEPPX	UEPXA	1.15	21.29	15.49	2.85	2.67					
	2-Wire Voice Unbundled PBX Toll Terminal Hotel Ports			UEPPX	UEPXB	1.15	21.29	15.49	2.85	2.67					
	2-Wire Voice Unbundled PBX LD DDD Terminals Port			UEPPX	UEPXC	1.15	21.29	15.49	2.85	2.67					
	2-Wire Voice Unbundled PBX LD Terminal Switchboard Port			UEPPX	UEPXD	1.15	21.29	15.49	2.85	2.67					
	2-Wire Voice Unbundled PBX LD Terminal Switchboard IDD Capable Port			UEPPX	UEPXE	1.15	21.29	15.49	2.85	2.67					
	2-Wire Voice Unbundled 2-Way PBX Kentucky Room Area Calling Port without LUD			UEPPX	UEPXF	1.15	21.29	15.49	2.85	2.67					
	2-Wire Voice Unbundled PBX Kentucky LUD Area Calling Port			UEPPX	UEPXG	1.15	21.29	15.49	2.85	2.67					
	2-Wire Voice Unbundled PBX Kentucky Premium Calling Port			UEPPX	UEPXH	1.15	21.29	15.49	2.85	2.67					
	2-Wire Voice Unbundled 2-Way Kentucky Area Calling Port without LUD			UEPPX	UEPXJ	1.15	21.29	15.49	2.85	2.67					
	2-Wire Voice Unbundled OutDial Kentucky NAR Area Calling Port			UEPPX	UEPOK	1.15	21.29	15.49	2.85	2.67					
	2-Wire Voice Unbundled 2-Way PBX Hotel/Hospital Economy Administrative Calling Port			UEPPX	UEPXL	1.15	21.29	15.49	2.85	2.67					
	2-Wire Voice Unbundled 2-Way PBX Hotel/Hospital Economy Room Calling Port			UEPPX	UEPXM	1.15	21.29	15.49	2.85	2.67					
	2-Wire Voice Unbundled 1-Way Outgoing PBX Hotel/Hospital Discount Room Calling Port			UEPPX	UEPXO	1.15	21.29	15.49	2.85	2.67					
	2-Wire Voice Unbundled 1-Way Outgoing PBX Measured Port			UEPPX	UEPXS	1.15	21.29	15.49	2.85	2.67					
<b>LOCAL NUMBER PORTABILITY</b>															
	Local Number Portability (1 per port)			UEPPX	LNPCP	3.15	0.00	0.00							
<b>FEATURES</b>															
	All Features Offered			UEPPX	UEPVF	0.00	0.00	0.00							
<b>NONRECURRING CHARGES (NRCs) - CURRENTLY COMBINED</b>															
	2-Wire Voice Grade Loop/ Line Port Combination (PBX) - Conversion - Switch-As-Is			UEPPX	USAC2		8.45	1.91							
	2-Wire Voice Grade Loop/ Line Port Combination (PBX) - Conversion - Switch with Change			UEPPX	USACC		8.45	1.91							
<b>ADDITIONAL NRCs</b>															
	2-Wire Voice Grade Loop/ Line Port Combination (PBX) - Subsequent Activity			UEPPX	USAS2	0.00	0.00	0.00							
	PBX Subsequent Activity - Change/Rearrange Multiline Hunt Group						7.86	7.86							
	Unbundled Miscellaneous Rate Element, Tag Loop at End User Premise			UEPPX	URETL		8.33	0.83							
<b>OFF/ON PREMISES EXTENSION CHANNELS</b>															
	Local Channel Voice grade, per termination		1	UEPPX	P2JHX	12.67	134.89	81.87	73.65	14.88					
	Local Channel Voice grade, per termination		2	UEPPX	P2JHX	17.45	134.89	81.87	73.65	14.88					
	Local Channel Voice grade, per termination		3	UEPPX	P2JHX	33.22	134.89	81.87	73.65	14.88					
	Non-Wire Direct Serve Channel Voice Grade		1	UEPPX	SDD2X	12.68	170.06	78.10	119.62	15.80					
	Non-Wire Direct Serve Channel Voice Grade		2	UEPPX	SDD2X	18.12	170.06	78.10	119.62	15.80					
	Non-Wire Direct Serve Channel Voice Grade		3	UEPPX	SDD2X	29.64	170.06	78.10	119.62	15.00					
<b>INTEROFFICE TRANSPORT</b>															
	Interoffice Transport - Dedicated - 2 Wire Voice Grade - Facility Termination			UEPPX	U1TV2	23.95	98.09	53.67	56.31	22.42					

UNBUNDLED NETWORK ELEMENTS - Kentucky														Attachment: 2		Exhibit: A					
CATEGORY	RATE ELEMENTS	Interim	Zone	BCS	USOC	RATES (\$)	Svc Order Submitted Elec per LSR	Svc Order Submitted Manually per LSR	Incremental Charge - Manual Svc Order vs. Electronic-1st	Incremental Charge - Manual Svc Order vs. Electronic-Add'l	Incremental Charge - Manual Svc Order vs. Electronic-Disc 1st	Incremental Charge - Manual Svc Order vs. Electronic-Disc Add'l	OSS Rates (\$)								
													Rec	Nonrecurring		Nonrecurring Disconnect		SOME	SOMAN	SOMAN	SOMAN
													First	Add'l	First	Add'l					
	Interoffice Transport - Dedicated - 2 Wire Voice Grade - Per Mile or Fraction Mile			UEPPX	U1TVM	0.0095															
	<b>2-WIRE VOICE GRADE LOOP WITH 2-WIRE ANALOG LINE COIN PORT UNE Port/Loop Combination Rates</b>																				
	2-Wire VG Coin Port/Loop Combo - Zone 1		1			10.79															
	2-Wire VG Coin Port/Loop Combo - Zone 2		2			15.52															
	2-Wire VG Coin Port/Loop Combo - Zone 3		3			31.74															
	<b>UNE Loop Rates</b>																				
	2-Wire Voice Grade Loop (SL1) - Zone 1		1	UEPCO	UEPLX	9.64															
	2-Wire Voice Grade Loop (SL1) - Zone 2		2	UEPCO	UEPLX	14.37															
	2-Wire Voice Grade Loop (SL1) - Zone 3		3	UEPCO	UEPLX	30.59															
	<b>2-Wire Voice Grade Line Ports (COIN)</b>																				
	2-Wire Coin 2-Way without Operator Screening and without Blocking (AL, KY, LA, MS)			UEPCO	UEPRF	1.15	21.29	15.49	2.85	2.67											
	2-Wire Coin 2-Way with Operator Screening (AL, KY)			UEPCO	UEPRE	1.15	21.29	15.49	2.85	2.67											
	2-Wire Coin 2-Way with Operator Screening and Blocking: 011, 900/976, 1+DDD (AL, KY, LA, MS)			UEPCO	UEPRA	1.15	21.29	15.49	2.85	2.67											
	2-Wire Coin 2-Way with Operator Screening and 011 Blocking (KY)			UEPCO	UEPKA	1.15	21.29	15.49	2.85	2.67											
	2-Wire Coin 2-Way with Operator Screening & Blocking: 900/976, 1+DDD, 011+, & Local (AL, KY, LA, MS)			UEPCO	UEPCD	1.15	21.29	15.49	2.85	2.67											
	2-Wire Coin Outward without Blocking and without Operator Screening (KY, LA, MS)			UEPCO	UEPRN	1.15	21.29	15.49	2.85	2.67											
	2-Wire Coin Outward with Operator Screening and 011 Blocking (GA, KY, MS)			UEPCO	UEPRJ	1.15	21.29	15.49	2.85	2.67											
	2-Wire Coin Outward with Operator Screening and Blocking: 011, 900/976, 1+DDD (AL, KY, LA, MS)			UEPCO	UEPRH	1.15	21.29	15.49	2.85	2.67											
	2-Wire Coin Outward Operator Screening & Blocking: 900/976, 1+DDD, 011+, and Local (AL, KY, LA, MS)			UEPCO	UEPCN	1.15	21.29	15.49	2.85	2.67											
	2-Wire 2-Way Smartline with 900/976 (all states except LA)			UEPCO	UEPCK	1.15	21.29	15.49	2.85	2.67											
	2-Wire Coin Outward Smartline with 900/976 (all states except LA)			UEPCO	UEPCR	1.15	21.29	15.49	2.85	2.67											
	<b>ADDITIONAL UNE COIN PORT/LOOP (RC)</b>																				
	UNE Coin Port/Loop Combo Usage (Flat Rate)			UEPCO	URECU	2.57	0.00	0.00	0.00	0.00											
	<b>LOCAL NUMBER PORTABILITY</b>																				
	Local Number Portability (1 per port)			UEPCO	LNPCX	0.35															
	<b>NONRECURRING CHARGES - CURRENTLY COMBINED</b>																				
	2-Wire Voice Grade Loop / Line Port Combination - Conversion - Switch-as-is			UEPCO	USAC2		0.10	0.10													
	2-Wire Voice Grade Loop / Line Port Combination - Conversion - Switch with change			UEPCO	USACC		0.10	0.10													
	<b>ADDITIONAL NRCs</b>																				
	2-Wire Voice Grade Loop/Line Port Combination - Subsequent Activity			UEPCO	USAS2		0.00	0.00													
	Unbundled Miscellaneous Rate Element, Tag Loop at End User Premise			UEPCO	URETL		8.33	0.83													
	<b>2-WIRE VOICE LOOP/ 2WIRE VOICE GRADE IO TRANSPORT/ 2-WIRE LINE PORT (RES)</b>																				
	<b>UNE Port/Loop Combination Rates</b>																				
	2-Wire VG Loop/IO Transport/Port Combo - Zone 1		1			13.90															
	2-Wire VG Loop/IO Transport/Port Combo - Zone 2		2			18.68															
	2-Wire VG Loop/IO Transport/Port Combo - Zone 3		3			34.45															
	<b>UNE Loop Rates</b>																				
	2-Wire Voice Grade Loop (SL2) - Zone 1		1	UEPFR	UECF2	12.67															
	2-Wire Voice Grade Loop (SL2) - Zone 2		2	UEPFR	UECF2	17.45															
	2-Wire Voice Grade Loop (SL2) - Zone 3		3	UEPFR	UECF2	33.22															
	<b>2-Wire Voice Grade Line Port Rates (Res)</b>																				
	2-Wire voice unbundled port - residence			UEPFR	UEPRL	1.23	128.96	64.11	61.92	9.97											
	2-Wire voice unbundled port with Caller ID - res			UEPFR	UEPRC	1.23	128.96	64.11	61.92	9.97											
	2-Wire voice unbundled port outgoing only - res			UEPFR	UEPRO	1.23	128.96	64.11	61.92	9.97											
	2-Wire voice Grade unbundled Kentucky extended local dialing parity port with Caller ID - res			UEPFR	UEPRM	1.23	128.96	64.11	61.92	9.97											

UNBUNDLED NETWORK ELEMENTS - Kentucky														Attachment: 2		Exhibit: A				
CATEGORY	RATE ELEMENTS	Interim	Zone	BCS	USOC	RATES (\$)	Svc Order Submitted Elec per LSR	Svc Order Submitted Manually per LSR	Incremental Charge - Manual Svc Order vs. Electronic-1st	Incremental Charge - Manual Svc Order vs. Electronic-Add'l	Incremental Charge - Manual Svc Order vs. Electronic-Disc 1st	Incremental Charge - Manual Svc Order vs. Electronic-Disc Add'l	OSS Rates (\$)							
													Rec	Nonrecurring		Nonrecurring Disconnect		SOME	SOMAN	SOMAN
													First	Add'l	First	Add'l				
	2-Wire voice unbundles res, low usage line port with Caller ID (LUM)			UEPFR	UEPAP	1.23							128.96	64.11	61.92	9.97				
	2-Wire Voice Unbundled Kentucky Residence Dialing Plan without Caller ID			UEPFR	UEPWE	1.23							128.96	64.11	61.92	9.97				
	<b>INTEROFFICE TRANSPORT</b>																			
	Interoffice Transport - Dedicated - 2 Wire Voice Grade - Facility Termination			UEPFR	U1TV2	23.95							98.09	53.67	56.31	22.42				
	Interoffice Transport - Dedicated - 2 Wire Voice Grade - Per Mile or Fraction Mile			UEPFR	1L5XX	0.0095														
	<b>FEATURES</b>																			
	All Features Offered			UEPFR	UEPVF	0.00		0.00												
	<b>LOCAL NUMBER PORTABILITY</b>																			
	Local Number Portability (1 per port)			UEPFR	LNPCX	0.35														
	<b>NONRECURRING CHARGES (NRCs) - CURRENTLY COMBINED</b>																			
	2-Wire Loop / Dedicated IO Transport / 2 Wire Line Port Combination - Conversion - Switch-as-is			UEPFR	USAC2								9.03	1.87						
	2-Wire Loop / Dedicated IO Transport / 2 Wire Line Port Combination - Conversion - Switch-With-Change			UEPFR	USACC								9.03	1.87						
	Unbundled Miscellaneous Rate Element, Tag Designed Loop at End User Premise			UEPFR	URETN								11.21	1.10						
	<b>2-WIRE VOICE LOOP/ 2WIRE VOICE GRADE IO TRANSPORT/ 2-WIRE LINE PORT (BUS)</b>																			
	<b>UNE Port/Loop Combination Rates</b>																			
	2-Wire VG Loop/IO Tranport/Port Combo - Zone 1		1										13.90							
	2-Wire VG Loop/IO Tranport/Port Combo - Zone 2		2										18.68							
	2-Wire VG Loop/IO Tranport/Port Combo - Zone 3		3										34.45							
	<b>UNE Loop Rates</b>																			
	2-Wire Voice Grade Loop (SL2) - Zone 1		1	UEPFB	UECF2								12.67							
	2-Wire Voice Grade Loop (SL2) - Zone 2		2	UEPFB	UECF2								17.45							
	2-Wire Voice Grade Loop (SL2) - Zone 3		3	UEPFB	UECF2								33.22							
	<b>2-Wire Voice Grade Line Port (Bus)</b>																			
	2-Wire voice unbundled port without Caller ID - bus			UEPFB	UEPBL	1.23							128.96	64.11	61.92	9.97				
	2-Wire voice unbundled port with Caller + E484 ID - bus			UEPFB	UEPBC	1.23							128.96	64.11	61.92	9.97				
	2-Wire voice unbundled port outgoing only - bus			UEPFB	UEPBO	1.23							128.96	64.11	61.92	9.97				
	2-Wire voice Grade unbundled Kentucky extended local dialing parity port with Caller ID - bus			UEPFB	UEPBM	1.23							128.96	64.11	61.92	9.97				
	2-Wire voice unbundled incoming only port with Caller ID - Bus			UEPFB	UEPB1	1.23							128.96	64.11	61.92	9.97				
	2-Wire Voice Unbundled Kentucky Business Dialing Plan without Caller ID			UEPFB	UEPWF	1.23							128.96	64.11	61.92	9.97				
	<b>LOCAL NUMBER PORTABILITY</b>																			
	Local Number Portability (1 per port)			UEPFB	LNPCX	0.35														
	<b>INTEROFFICE TRANSPORT</b>																			
	Interoffice Transport - Dedicated - 2 Wire Voice Grade - Facility Termination			UEPFB	U1TV2	23.95							98.09	53.67	56.31	22.42				
	Interoffice Transport - Dedicated - 2 Wire Voice Grade - Per Mile or Fraction Mile			UEPFB	1L5XX	0.0095														
	<b>FEATURES</b>																			
	All Features Offered			UEPFB	UEPVF	0.00		0.00												
	<b>NONRECURRING CHARGES (NRCs) - CURRENTLY COMBINED</b>																			
	2-Wire Loop / Dedicated IO Transport / 2 Wire Line Port Combination - Conversion - Switch-as-is			UEPFB	USAC2								9.03	1.87						
	2-Wire Loop / Dedicated IO Transport / 2 Wire Line Port Combination - Conversion - Switch with change			UEPFB	USACC								9.03	1.87						
	Unbundled Miscellaneous Rate Element, Tag Designed Loop at End User Premise			UEPFB	URETN								11.21	1.10						
	<b>2-WIRE VOICE LOOP/ 2WIRE VOICE GRADE IO TRANSPORT/ 2-WIRE LINE PORT (PBX)</b>																			
	<b>UNE Port/Loop Combination Rates</b>																			
	2-Wire VG Loop/IO Tranport/Port Combo - Zone 1		1										13.90							
	2-Wire VG Loop/IO Tranport/Port Combo - Zone 2		2										18.68							
	2-Wire VG Loop/IO Tranport/Port Combo - Zone 3		3										34.45							
	<b>UNE Loop Rates</b>																			
	2-Wire Voice Grade Loop (SL2) - Zone 1		1	UEPFB	UECF2								12.67							
	2-Wire Voice Grade Loop (SL2) - Zone 2		2	UEPFB	UECF2								17.45							





UNBUNDLED NETWORK ELEMENTS - Kentucky											Attachment: 2		Exhibit: A							
CATEGORY	RATE ELEMENTS	Interim	Zone	BCS	USOC	RATES (\$)	Svc Order Submitted Elec per LSR	Svc Order Submitted Manually per LSR	Incremental Charge - Manual Svc Order vs. Electronic-1st	Incremental Charge - Manual Svc Order vs. Electronic-Add'l	Incremental Charge - Manual Svc Order vs. Electronic-Disc 1st	Incremental Charge - Manual Svc Order vs. Electronic-Disc Add'l	OSS Rates (\$)							
													Rec	Nonrecurring		Nonrecurring Disconnect		SOME C	SOMAN	SOMAN
													First	Add'l	First	Add'l				
	Additional DID Numbers for each Group of 20 DID Numbers			UEPPX	ND4	0.00														
	DID Numbers, Non- consecutive DID Numbers , Per Number			UEPPX	ND5	0.00														
	Reserve Non-Consecutive DID numbers			UEPPX	ND6	0.00														
	Reserve DID Numbers			UEPPX	NDV	0.00														
	<b>LOCAL NUMBER PORTABILITY</b>																			
	Local Number Portability (1 per port)			UEPPX	LNPCP	3.15		0.00												
	<b>2-WIRE ISDN DIGITAL GRADE LOOP WITH 2-WIRE ISDN DIGITAL LINE SIDE PORT</b>																			
	<b>UNE Port/Loop Combination Rates</b>																			
	2W ISDN Digital Grade Loop/2W ISDN Digital Line Side Port - UNE Zone 1		1	UEPPB	UEPPR	25.69														
	2W ISDN Digital Grade Loop/2W ISDN Digital Line Side Port - UNE Zone 2		2	UEPPB	UEPPR	31.92														
	2W ISDN Digital Grade Loop/2W ISDN Digital Line Side Port - UNE Zone 3		3	UEPPB	UEPPR	50.21														
	<b>UNE Loop Rates</b>																			
	2-Wire ISDN Digital Grade Loop - UNE Zone 1		1	UEPPB	UEPPR	USL2X		16.10												
	2-Wire ISDN Digital Grade Loop - UNE Zone 2		2	UEPPB	UEPPR	USL2X		22.33												
	2-Wire ISDN Digital Grade Loop - UNE Zone 3		3	UEPPB	UEPPR	USL2X		40.63												
	<b>UNE Port Rate</b>																			
	Exchange Port - 2-Wire ISDN Line Side Port			UEPPB	UEPPR	UEPPB		9.59	320.53	289.13	92.19	17.56								
	<b>NONRECURRING CHARGES - CURRENTLY COMBINED</b>																			
	2-Wire ISDN Digital Grade Loop / 2-Wire ISDN Line Side Port Combination - Conversion			UEPPB	UEPPR	USACB		0.00	22.77	17.00										
	<b>ADDITIONAL NRCs</b>																			
	Unbundled Miscellaneous Rate Element, Tag Designed Loop at End User Premise			UEPPB	UEPPR	URETN			11.21	1.10										
	Unbundled Miscellaneous Rate Element, Tag Loop at End User Premise			UEPPB	UEPPR	URETL			8.33	0.83										
	<b>LOCAL NUMBER PORTABILITY</b>																			
	Local Number Portability (1 per port)			UEPPB	UEPPR	LNPCX		0.35	0.00	0.00										
	<b>B-CHANNEL USER PROFILE ACCESS:</b>																			
	CVS/CSD (DMS/5ESS)			UEPPB	UEPPR	U1UCA		0.00	0.00	0.00										
	CVS (EWSD)			UEPPB	UEPPR	U1UCB		0.00	0.00	0.00										
	CSD			UEPPB	UEPPR	U1UCC		0.00	0.00	0.00										
	<b>B-CHANNEL AREA PLUS USER PROFILE ACCESS: (AL,KY,LA,MS SC,MS, &amp; TN)</b>																			
	CVS/CSD (DMS/5ESS)			UEPPB	UEPPR	U1UCD		0.00	0.00	0.00										
	CVS (EWSD)			UEPPB	UEPPR	U1UCE		0.00	0.00	0.00										
	CSD			UEPPB	UEPPR	U1UCF		0.00	0.00	0.00										
	<b>USER TERMINAL PROFILE</b>																			
	User Terminal Profile (EWSD only)			UEPPB	UEPPR	U1UMA		0.00	0.00	0.00										
	<b>VERTICAL FEATURES</b>																			
	All Vertical Features - One per Channel B User Profile			UEPPB	UEPPR	UEPVF		0.00	0.00	0.00										
	<b>INTEROFFICE CHANNEL MILEAGE</b>																			
	Interoffice Channel mileage each, including first mile and facilities termination			UEPPB	UEPPR	M1GNC		29.12	47.34	31.78	22.77	8.75								
	Interoffice Channel mileage each, additional mile			UEPPB	UEPPR	M1GNM		0.01	0.00	0.00										
	<b>4-WIRE DS1 DIGITAL LOOP WITH 4-WIRE ISDN DS1 DIGITAL TRUNK PORT</b>																			
	<b>UNE Port/Loop Combination Rates</b>																			
	4W DS1 Digital Loop/4W ISDN DS1 Digital Trunk Port - UNE Zone 1		1	UEPPP		170.06														
	4W DS1 Digital Loop/4W ISDN DS1 Digital Trunk Port - UNE Zone 2		2	UEPPP		197.70														
	4W DS1 Digital Loop/4W ISDN DS1 Digital Trunk Port - UNE Zone 3		3	UEPPP		381.35														
	<b>UNE Loop Rates</b>																			
	4-Wire DS1 Digital Loop - UNE Zone 1		1	UEPPP		USL4P		86.47												
	4-Wire DS1 Digital Loop - UNE Zone 2		2	UEPPP		USL4P		114.10												
	4-Wire DS1 Digital Loop - UNE Zone 3		3	UEPPP		USL4P		297.76												
	<b>UNE Port Rate</b>																			
	Exchange Ports - 4-Wire ISDN DS1 Port (E-4/1/2004)			UEPPP		UEPPP		83.59	736.16	382.74	159.48	48.82								
	<b>NONRECURRING CHARGES - CURRENTLY COMBINED</b>																			

UNBUNDLED NETWORK ELEMENTS - Kentucky														Attachment: 2		Exhibit: A					
CATEGORY	RATE ELEMENTS	Interim	Zone	BCS	USOC	RATES (\$)	Svc Order Submitted Elec per LSR	Svc Order Submitted Manually per LSR	Incremental Charge - Manual Svc Order vs. Electronic-1st	Incremental Charge - Manual Svc Order vs. Electronic-Add'l	Incremental Charge - Manual Svc Order vs. Electronic-Disc 1st	Incremental Charge - Manual Svc Order vs. Electronic-Disc Add'l	OSS Rates (\$)								
													Rec	Nonrecurring		Nonrecurring Disconnect		SOME	SOMAN	SOMAN	SOMAN
													First	Add'l	First	Add'l	SOME	SOMAN	SOMAN	SOMAN	
	4-Wire DS1 Digital Loop / 4-Wire ISDN DS1 Digital Trunk Port Combination - Conversion -Switch-as-is (E:4/1/2004)			UEPPP	USACP	0.00							81.70	61.37							
	<b>ADDITIONAL NRCs</b>																				
	4-Wire DS1 Loop/4-W ISDN Digtl Trk Port - Subsqct Actvy-Inward/two way Tel Nos. (except NC)			UEPPP	PR7TF	0.54															
	4-Wire DS1 Loop / 4-Wire ISDN DS1 Digital Trunk Port - Outward Tel Numbers (All States except NC)			UEPPP	PR7TO	12.71							12.71								
	4-Wire DS1 Loop / 4-Wire ISDN DS1 Digital Trk Port - Subsequent Inward Tel Numbers			UEPPP	PR7ZT	25.41							25.41								
	<b>LOCAL NUMBER PORTABILITY</b>																				
	Local Number Portability (1 per port)			UEPPP	LNPCN	1.75															
	<b>INTERFACE (Provisioning Only)</b>																				
	Voice/Data			UEPPP	PR71V	0.00	0.00	0.00													
	Digital Data			UEPPP	PR71D	0.00	0.00	0.00													
	Inward Data			UEPPP	PR71E	0.00	0.00	0.00													
	<b>New or Additional "B" Channel</b>																				
	New or Additional - Voice/Data B Channel			UEPPP	PR7BV	0.00	15.48														
	New or Additional - Digital Data B Channel			UEPPP	PR7BF	0.00	15.48														
	New or Additional Inward Data B Channel			UEPPP	PR7BD	0.00	15.48														
	<b>CALL TYPES</b>																				
	Inward			UEPPP	PR7C1	0.00	0.00	0.00													
	Outward			UEPPP	PR7CO	0.00	0.00	0.00													
	Two-way			UEPPP	PR7CC	0.00	0.00	0.00													
	<b>Interoffice Channel Mileage</b>																				
	Fixed Each Including First Mile			UEPPP	1LN1A	96.27	105.52	98.46	23.09	20.49											
	Each Airline-Fractional Additional Mile			UEPPP	1LN1B	0.23															
	<b>4-WIRE DS1 DIGITAL LOOP WITH 4-WIRE DDITS TRUNK PORT</b>																				
	<b>UNE Port/Loop Combination Rates</b>																				
	4W DS1 Digital Loop/4W DDITS Trunk Port - UNE Zone 1		1	UEPDC		147.99															
	4W DS1 Digital Loop/4W DDITS Trunk Port - UNE Zone 2		2	UEPDC		175.62															
	4W DS1 Digital Loop/4W DDITS Trunk Port - UNE Zone 3		3	UEPDC		359.28															
	<b>UNE Loop Rates</b>																				
	4-Wire DS1 Digital Loop - UNE Zone 1		1	UEPDC	USLDC	86.47															
	4-Wire DS1 Digital Loop - UNE Zone 2		2	UEPDC	USLDC	114.10															
	4-Wire DS1 Digital Loop - UNE Zone 3		3	UEPDC	USLDC	297.76															
	<b>UNE Port Rate</b>																				
	4-Wire DDITS Digital Trunk Port (E:4/1/2004)			UEPDC	UDD1T	61.52	780.61	375.52	176.19	16.98											
	<b>NONRECURRING CHARGES - CURRENTLY COMBINED</b>																				
	4-Wire DS1 Digital Loop / 4-Wire DDITS Trunk Port Combination - Switch-as-is (E:4/1/2004)			UEPDC	USAC4		92.84	46.70													
	4-Wire DS1 Digital Loop / 4-Wire DDITS Trunk Port Combination - Conversion with DS1 Changes (E:4/1/2004)			UEPDC	USAWA		92.84	46.70													
	4-Wire DS1 Digital Loop / 4-Wire DDITS Trunk Port Combination - Conversion with Change - Trunk (E:4/1/2004)			UEPDC	USAWB		92.84	46.70													
	<b>ADDITIONAL NRCs</b>																				
	4-Wire DS1 Loop / 4-Wire DDITS Trunk Port - NRC - Subsequent Channel Activation/Chan - 2-Way Trunk			UEPDC	UDTTA		15.09	15.09													
	4-Wire DS1 Loop / 4-Wire DDITS Trunk Port - Subsequent Channel Activation/Chan - 1-Way Outward Trunk			UEPDC	UDTTB		15.09	15.09													
	4-Wire DS1 Loop / 4-Wire DDITS Trunk Port - Subsqct Channel Activation/Chan Inward Trunk w/out DID			UEPDC	UDTTC		15.09	15.09													
	4-Wire DS1 Loop / 4-Wire DDITS Trunk Port - Subsqct Chan Activation Per Chan - Inward Trunk with DID			UEPDC	UDTTD		15.09	15.09													
	4-Wire DS1 Loop / 4-Wire DDITS Trunk Port - Subsqct Chan Activation / Chan - 2-Way DID w User Trans			UEPDC	UDTTE		15.09	15.09													
	<b>BIPOLAR 8 ZERO SUBSTITUTION</b>																				
	B8ZS - Superframe Format			UEPDC	CCOSF	0.00i	730.00s														
	B8ZS - Extended Superframe Format			UEPDC	CCOEF	0.00i	730.00s														
	<b>Alternate Mark Inversion</b>																				
	AMI - Superframe Format			UEPDC	MCOSF		0.00	0.00													
	AMI - Extended SuperFrame Format			UEPDC	MCOPO		0.00	0.00													
	<b>Telephone Number/Trunk Group Establishment Charges</b>																				

UNBUNDLED NETWORK ELEMENTS - Kentucky											Attachment: 2		Exhibit: A							
CATEGORY	RATE ELEMENTS	Interim	Zone	BCS	USOC	RATES (\$)	Svc Order Submitted Elec per LSR	Svc Order Submitted Manually per LSR	Incremental Charge - Manual Svc Order vs. Electronic-1st	Incremental Charge - Manual Svc Order vs. Electronic-Add'l	Incremental Charge - Manual Svc Order vs. Electronic-Disc 1st	Incremental Charge - Manual Svc Order vs. Electronic-Disc Add'l	OSS Rates (\$)							
													Rec	Nonrecurring		Nonrecurring Disconnect		SOME	SOMAN	SOMAN
													First	Add'l	First	Add'l				
	Telephone Number for 2-Way Trunk Group			UEPDC	UDTGX	0.00														
	Telephone Number for 1-Way Outward Trunk Group			UEPDC	UDTGY	0.00														
	Telephone Number for 1-Way Inward Trunk Group Without DID			UEPDC	UDTGZ	0.00	0.00	0.00												
	DID Numbers for each Group of 20 DID Numbers			UEPDC	ND4	0.00	0.00	0.00												
	DID Numbers, Non-consecutive DID Numbers, Per Number			UEPDC	ND5	0.00	0.00	0.00												
	Reserve Non-Consecutive DID Nos.			UEPDC	ND6	0.00	0.00	0.00												
	Reserve DID Numbers			UEPDC	NDV	0.00	0.00	0.00												
<b>Dedicated DS1 (Interoffice Channel Mileage) - FX/FCO for 4-Wire DS1 Digital Loop with 4-Wire DDITS Trunk Port</b>																				
	Interoffice Channel Mileage - Fixed rate 0-8 miles (Facilities Termination)			UEPDC	1LNO1	96.04	105.52	98.46	23.09	20.49										
	Interoffice Channel Mileage - Additional rate per mile - 0-8 miles			UEPDC	1LNOA	0.23	0.00	0.00												
	Interoffice Channel Mileage - Fixed rate 9-25 miles (Facilities Termination)			UEPDC	1LNO2	0.00	0.00	0.00												
	Interoffice Channel Mileage - Additional rate per mile - 9-25 miles			UEPDC	1LNOB	0.45	0.00	0.00												
	Interoffice Channel Mileage - Fixed rate 25+ miles (Facilities Termination)			UEPDC	1LNO3	0.00	0.00	0.00												
	Interoffice Channel Mileage - Additional rate per mile - 25+ miles			UEPDC	1LNOC	0.45	0.00	0.00												
	Local Number Portability, per DS0 Activated			UEPDC	LNPCP	3.15	0.00	0.00												
	Central Office Terminating Point			UEPDC	CTG	0.00														
<b>4-WIRE DS1 LOOP WITH CHANNELIZATION WITH PORT</b>																				
<b>UNE DS1 Loop</b>																				
	4-Wire DS1 Loop - UNE Zone 1		1	UEPMG	USLDC	86.47	0.00	0.00												
	4-Wire DS1 Loop - UNE Zone 2		2	UEPMG	USLDC	114.10	0.00	0.00												
	4-Wire DS1 Loop - UNE Zone 3		3	UEPMG	USLDC	297.76	0.00	0.00												
<b>UNE DSO Channelization Capacities (D4 Channel Bank Configurations)</b>																				
	24 DSO Channel Capacity - 1 per DS1			UEPMG	VUM24	111.16	0.00	0.00												
	48 DSO Channel Capacity - 1 per 2 DS1s			UEPMG	VUM48	222.32	0.00	0.00												
	96 DSO Channel Capacity -1per 4 DS1s			UEPMG	VUM96	444.64	0.00	0.00												
	144 DSO Channel Capacity - 1 per 6 DS1s			UEPMG	VUM14	666.96	0.00	0.00												
	192 DSO Channel Capacity -1 per 8 DS1s			UEPMG	VUM19	889.28	0.00	0.00												
	240 DSO Channel Capacity - 1 per 10 DS1s			UEPMG	VUM20	1,111.60	0.00	0.00												
	288 DSO Channel Capacity - 1 per 12 DS1s			UEPMG	VUM28	1,333.92	0.00	0.00												
	384 DSO Channel Capacity - 1 per 16 DS1s			UEPMG	VUM38	1,778.56	0.00	0.00												
	480 DSO Channel Capacity - 1 per 20 DS1s			UEPMG	VUM40	2,223.20	0.00	0.00												
	576 DSO Channel Capacity -1 per 24 DS1s			UEPMG	VUM57	2,667.84	0.00	0.00												
	672 DSO Channel Capacity - 1 per 28 DS1s			UEPMG	VUM67	3,112.48	0.00	0.00												
<b>Non-Recurring Charges (NRC) Associated with 4-Wire DS1 Loop with Channelization with Port - Conversion Charge Based on a System</b>																				
<b>A Minimum System configuration is One (1) DS1, One (1) D4 Channel Bank, and Up To 24 DSO Ports with Feature Activations.</b>																				
<b>Multiples of this configuration functioning as one are considered Add'l after the minimum system configuration is counted.</b>																				
	NRC - Conversion (Currently Combined) with or without Bell/South Allowed Changes			UEPMG	USAC4	0.00	94.30	4.24												
<b>System Additions at End User Locations Where 4-Wire DS1 Loop with Channelization with Port Combination Currently Exists and</b>																				
<b>New (Not Currently Combined) in all states, except in Density Zone 1 of Top 8 MSA's</b>																				
	1 DS1/D4 Channel Bank - Additionally Add NRC for each Port and Assoc Fea Activation (E:4/1/2004)			UEPMG	VUMD4	0.00	718.89	469.86	149.83	17.77										
<b>Bipolar 8 Zero Substitution</b>																				
	Clear Channel Capability Format, superframe - Subsequent Activity Only			UEPMG	CCOSF	0.00	0.00i	730.00s												
	Clear Channel Capability Format - Extended Superframe - Subsequent Activity Only			UEPMG	CCOEF	0.00	0.00i	730.00s												
<b>Alternate Mark Inversion (AMI)</b>																				
	Superframe Format			UEPMG	MCOSF	0.00	0.00	0.00												
	Extended Superframe Format			UEPMG	MCOPO	0.00	0.00	0.00												
<b>Exchange Ports Associated with 4-Wire DS1 Loop with Channelization with Port</b>																				
<b>Exchange Ports</b>																				
	Line Side Combination Channelized PBX Trunk Port - Business (E:4/1/2004)			UEPPX	UEPCX	1.15	0.00	0.00	0.00	0.00										
	Line Side Outward Channelized PBX Trunk Port - Business (E:4/1/2004)			UEPPX	UEPOX	1.15	0.00	0.00	0.00	0.00										
	Line Side Inward Only Channelized PBX Trunk Port without DID (E:4/1/2004)			UEPPX	UEP1X	1.15	0.00	0.00	0.00	0.00										



UNBUNDLED NETWORK ELEMENTS - Kentucky														Attachment: 2		Exhibit: A				
CATEGORY	RATE ELEMENTS	Interim	Zone	BCS	USOC	RATES (\$)	Svc Order Submitted Elec per LSR	Svc Order Submitted Manually per LSR	Incremental Charge - Manual Svc Order vs. Electronic-1st	Incremental Charge - Manual Svc Order vs. Electronic-Add'l	Incremental Charge - Manual Svc Order vs. Electronic-Disc 1st	Incremental Charge - Manual Svc Order vs. Electronic-Disc Add'l	OSS Rates (\$)							
													Rec	Nonrecurring		Nonrecurring Disconnect		SOMEc	SOMAN	SOMAN
													First	Add'l	First	Add'l				
	2-Wire Voice Grade Port (Centrex 800 termination)Basic Local Area			UEP91	UEPYB	1.15							21.29	15.49	2.85	2.67				
	2-Wire Voice Grade Port (Centrex with Caller ID)Note1 Basic Local Area			UEP91	UEPYH	1.15							21.29	15.49	2.85	2.67				
	2-Wire Voice Grade Port (Centrex from diff Serving Wire Center) Note 2, 3 Basic Local Area			UEP91	UEPYM	1.15							21.29	15.49	2.85	2.67				
	2-Wire Voice Grade Port, Diff Serving Wire Center - 800 Service Term - Basic Local Area			UEP91	UEPYZ	1.15							21.29	15.49	2.85	2.67				
	2-Wire Voice Grade Port terminated in on Megalink or equivalent - Basic Local Area			UEP91	UEPY9	1.15							21.29	15.49	2.85	2.67				
	2-Wire Voice Grade Port Terminated on 800 Service Term - Basic Local Area			UEP91	UEPY2	1.15							21.29	15.49	2.85	2.67				
	<b>AL, KY, LA, MS, &amp; TN Only</b>																			
	2-Wire Voice Grade Port (Centrex )			UEP91	UEPQA	1.15							21.29	15.49	2.85	2.67				
	2-Wire Voice Grade Port (Centrex 800 termination)			UEP91	UEPQB	1.15							21.29	15.49	2.85	2.67				
	2-Wire Voice Grade Port (Centrex with Caller ID)1			UEP91	UEPQH	1.15							21.29	15.49	2.85	2.67				
	2-Wire Voice Grade Port (Centrex from diff Serving Wire Center)2,3			UEP91	UEPQM	1.15							21.29	15.49	2.85	2.67				
	2-Wire Voice Grade Port, Diff Serving Wire Center - 2,3 - 800 Service Term			UEP91	UEPQZ	1.15							21.29	15.49	2.85	2.67				
	2-Wire Voice Grade Port terminated in on Megalink or equivalent			UEP91	UEPQ9	1.15							21.29	15.49	2.85	2.67				
	2-Wire Voice Grade Port Terminated on 800 Service Term			UEP91	UEPQ2	1.15							21.29	15.49	2.85	2.67				
	<b>Local Switching</b>																			
	Centrex Intercom Functionality, per port			UEP91	URECS	0.8873														
	<b>Local Number Portability</b>																			
	Local Number Portability (1 per port)			UEP91	LNPCc	0.35														
	<b>Features</b>																			
	All Standard Features Offered, per port			UEP91	UEPVF	0.00														
	All Select Features Offered, per port			UEP91	UEPVS	0.00							405.66							
	All Centrex Control Features Offered, per port			UEP91	UEPVC	0.00														
	<b>NARS</b>																			
	Unbundled Network Access Register - Combination			UEP91	UARCX	0.00	0.00	0.00	0.00	0.00										
	Unbundled Network Access Register - Indial			UEP91	UAR1X	0.00	0.00	0.00	0.00	0.00										
	Unbundled Network Access Register - Outdial			UEP91	UAROx	0.00	0.00	0.00	0.00	0.00										
	<b>Miscellaneous Terminations</b>																			
	<b>2-Wire Trunk Side</b>																			
	Trunk Side Terminations, each			UEP91	CENA6	10.51	92.18	15.82	52.16	5.30										
	<b>Interoffice Channel Mileage - 2-Wire</b>																			
	Interoffice Channel Facilities Termination - Voice Grade			UEP91	M1GBC	29.11														
	Interoffice Channel mileage, per mile or fraction of mile			UEP91	M1GBM	0.01														
	<b>Feature Activations (DS0) Centrex Loops on Channelized DS1 Service</b>																			
	<b>D4 Channel Bank Feature Activations</b>																			
	Feature Activation on D-4 Channel Bank Centrex Loop Slot			UEP91	1PQWS	0.62														
	Feature Activation on D-4 Channel Bank FX line Side Loop Slot			UEP91	1PQW6	0.62														
	Feature Activation on D-4 Channel Bank FX Trunk Side Loop Slot			UEP91	1PQW7	0.62														
	Feature Activation on D-4 Channel Bank Centrex Loop Slot - Different Wire Center			UEP91	1PQWP	0.62														
	Feature Activation on D-4 Channel Bank Private Line Loop Slot			UEP91	1PQWV	0.62														
	Feature Activation on D-4 Channel Bank Tjje Line/Trunk Loop Slot			UEP91	1PQWQ	0.62														
	Feature Activation on D-4 Channel Bank WATS Loop Slot			UEP91	1PQWA	0.62														
	<b>Non-Recurring Charges (NRC) Associated with UNE-P Centrex</b>																			
	Conversion - Currently Combined Switch-As-Is with allowed changes, per port			UEP91	USAC2		0.102	0.102												
	Conversion of Existing Centrex Common Block			UEP91	USACN		18.95	8.32												
	New Centrex Standard Common Block			UEP91	M1ACS	0.00	669.80	78.32	111.05	13.27										
	New Centrex Customized Common Block			UEP91	M1ACC	0.00	669.80	78.32	111.05	13.27										
	Secondary Block, per Block			UEP91	M2CC1	0.00	78.32	78.32	13.27	13.27										
	NAR Establishment Charge, Per Occasion			UEP91	URECA	0.00	72.75													
	<b>Additional Non-Recurring Charges (NRC)</b>																			

UNBUNDLED NETWORK ELEMENTS - Kentucky														Attachment: 2		Exhibit: A			
CATEGORY	RATE ELEMENTS	Interim	Zone	BCS	USOC	RATES (\$)	Svc Order Submitted Elec per LSR	Svc Order Submitted Manually per LSR	Incremental Charge - Manual Svc Order vs. Electronic-1st	Incremental Charge - Manual Svc Order vs. Electronic-Add'l	Incremental Charge - Manual Svc Order vs. Electronic-Disc 1st	Incremental Charge - Manual Svc Order vs. Electronic-Disc Add'l	OSS Rates (\$)						
													Rec	Nonrecurring		Nonrecurring Disconnect		SOMEC	SOMAN
	Unbundled Miscellaneous Rate Element, Tag Loop at End Use Premise			UEP91	URETL	8.33		0.83											
	Unbundled Miscellaneous Rate Element, Tag Design Loop at End Use Premise			UEP91	URETN	11.21		1.10											
<b>UNE-P CENTREX - 5ESS (Valid in All States)</b>																			
<b>2-Wire VG Loop/2-Wire Voice Grade Port (Centrex) Combo</b>																			
<b>UNE Port/Loop Combination Rates (Non-Design)</b>																			
	2-Wire VG Loop/2-Wire Voice Grade Port (Centrex) Port Combo - Non-Design		1	UEP95		10.79													
	2-Wire VG Loop/2-Wire Voice Grade Port (Centrex)Port Combo - Non-Design		2	UEP95		15.52													
	2-Wire VG Loop/2-Wire Voice Grade Port (Centrex)Port Combo - Non-Design		3	UEP95		31.74													
<b>UNE Port/Loop Combination Rates (Design)</b>																			
	2-Wire VG Loop/2-Wire Voice Grade Port (Centrex) Port Combo - Design		1	UEP95		13.82													
	2-Wire VG Loop/2-Wire Voice Grade Port (Centrex)Port Combo - Design		2	UEP95		18.60													
	2-Wire VG Loop/2-Wire Voice Grade Port (Centrex)Port Combo - Design		3	UEP95		34.37													
<b>UNE Loop Rate</b>																			
	2-Wire Voice Grade Loop (SL 1) - Zone 1		1	UEP95	UECS1	9.64													
	2-Wire Voice Grade Loop (SL 1) - Zone 2		2	UEP95	UECS1	14.37													
	2-Wire Voice Grade Loop (SL 1) - Zone 3		3	UEP95	UECS1	30.59													
	2-Wire Voice Grade Loop (SL 2) - Zone 1		1	UEP95	UECS2	12.67													
	2-Wire Voice Grade Loop (SL 2) - Zone 2		2	UEP95	UECS2	17.45													
	2-Wire Voice Grade Loop (SL 2) - Zone 3		3	UEP95	UECS2	33.22													
<b>UNE Port Rate</b>																			
<b>All States</b>																			
	2-Wire Voice Grade Port (Centrex ) Basic Local Area			UEP95	UEPYA	1.15	21.29	15.49	2.85	2.67									
	2-Wire Voice Grade Port (Centrex 800 termination)			UEP95	UEPYB	1.15	21.29	15.49	2.85	2.67									
	2-Wire Voice Grade Port (Centrex with Caller ID)1Basic Local Area			UEP95	UEPYH	1.15	21.29	15.49	2.85	2.67									
	2-Wire Voice Grade Port (Centrex from diff Serving Wire Center)2,3 Basic Local Area			UEP95	UEPYM	1.15	21.29	15.49	2.85	2.67									
	2-Wire Voice Grade Port, Diff Serving Wire Center 2,3 - 800 Service Term - Basic Local Area			UEP95	UEPYZ	1.15	21.29	15.49	2.85	2.67									
	2-Wire Voice Grade Port terminated in on Megalink or equivalent - Basic Local Area			UEP95	UEPY9	1.15	21.29	15.49	2.85	2.67									
	2-Wire Voice Grade Port Terminated on 800 Service Term - Basic Local Area			UEP95	UEPY2	1.15	21.29	15.49	2.85	2.67									
<b>AL, KY, LA, MS, SC, &amp; TN Only</b>																			
	2-Wire Voice Grade Port (Centrex )			UEP95	UEPQA	1.15	21.29	15.49	2.85	2.67									
	2-Wire Voice Grade Port (Centrex 800 termination)			UEP95	UEPQB	1.15	21.29	15.49	2.85	2.67									
	2-Wire Voice Grade Port (Centrex with Caller ID)1			UEP95	UEPQH	1.15	21.29	15.49	2.85	2.67									
	2-Wire Voice Grade Port (Centrex from diff Serving Wire Center)2,3			UEP95	UEPQM	1.15	21.29	15.49	2.85	2.67									
	2-Wire Voice Grade Port, Diff Serving Wire Center - 800 Service Term 2,3			UEP95	UEPQZ	1.15	21.29	15.49	2.85	2.67									
	2-Wire Voice Grade Port terminated in on Megalink or equivalent			UEP95	UEPQ9	1.15	21.29	15.49	2.85	2.67									
	2-Wire Voice Grade Port Terminated on 800 Service Term			UEP95	UEPQ2	1.15	21.29	15.49	2.85	2.67									
<b>Local Switching</b>																			
	Centrex Intercom Functionality, per port			UEP95	URECS	0.8873													
<b>Local Number Portability</b>																			
	Local Number Portability (1 per port)			UEP95	LNPC	0.35													
<b>Features</b>																			
	All Standard Features Offered, per port			UEP95	UEPVF	0.00													
	All Select Features Offered, per port			UEP95	UEPVS	0.00	405.66												
	All Centrex Control Features Offered, per port			UEP95	UEPVC	0.00													
<b>NARS</b>																			
	Unbundled Network Access Register - Combination			UEP95	UARCX	0.00	0.00	0.00	0.00	0.00									

UNBUNDLED NETWORK ELEMENTS - Kentucky														Attachment: 2		Exhibit: A				
CATEGORY	RATE ELEMENTS	Interim	Zone	BCS	USOC	RATES (\$)	Svc Order Submitted Elec per LSR	Svc Order Submitted Manually per LSR	Incremental Charge - Manual Svc Order vs. Electronic-1st	Incremental Charge - Manual Svc Order vs. Electronic-Add'l	Incremental Charge - Manual Svc Order vs. Electronic-Disc 1st	Incremental Charge - Manual Svc Order vs. Electronic-Disc Add'l	OSS Rates (\$)							
													Rec	Nonrecurring		Nonrecurring Disconnect		SOMEc	SOMAN	SOMAN
													First	Add'l	First	Add'l				
	Unbundled Network Access Register - Indial			UEP95	UAR1X	0.00							0.00	0.00	0.00	0.00				
	Unbundled Network Access Register - Outdial			UEP95	UAROx	0.00							0.00	0.00	0.00	0.00				
<b>Miscellaneous Terminations</b>																				
<b>2-Wire Trunk Side</b>																				
	Trunk Side Terminations, each			UEP95	CEND6	10.51							92.18	15.82	52.16	5.30				
<b>4-Wire Digital (1.544 Megabits)</b>																				
	DS1 Circuit Terminations, each			UEP95	M1HD1	74.77							164.86	77.74	60.69	3.86				
	DS0 Channels Activated, each			UEP95	M1HDO	0.00							15.09							
<b>Interoffice Channel Mileage - 2-Wire</b>																				
	Interoffice Channel Facilities Termination			UEP95	M1GBC	29.11														
	Interoffice Channel mileage, per mile or fraction of mile			UEP95	M1GBM	0.01														
<b>Feature Activations (DS0) Centrex Loops on Channelized DS1 Service</b>																				
<b>D4 Channel Bank Feature Activations</b>																				
	Feature Activation on D-4 Channel Bank Centrex Loop Slot			UEP95	1PQWS	0.62														
	Feature Activation on D-4 Channel Bank FX line Side Loop Slot			UEP95	1PQW6	0.62														
	Feature Activation on D-4 Channel Bank FX Trunk Side Loop Slot			UEP95	1PQW7	0.62														
	Feature Activation on D-4 Channel Bank Centrex Loop Slot - Different Wire Center			UEP95	1PQWP	0.62														
	Feature Activation on D-4 Channel Bank Private Line Loop Slot			UEP95	1PQWV	0.62														
	Feature Activation on D-4 Channel Bank Tjje Line/Trunk Loop Slot			UEP95	1PQWQ	0.62														
	Feature Activation on D-4 Channel Bank WATS Loop Slot			UEP95	1PQWA	0.62														
<b>Non-Recurring Charges (NRC) Associated with UNE-P Centrex</b>																				
	NRC Conversion Currently Combined Switch-As-Is with allowed changes, per port			UEP95	USAC2								0.102	0.102						
	Conversion of Existing Centrex Common Block, each			UEP95	USACN								18.95	8.32						
	New Centrex Standard Common Block			UEP95	M1ACS	0.00							669.80	78.32	111.05	13.27				
	New Centrex Customized Common Block			UEP95	M1ACC	0.00							669.80	78.32	111.05	13.27				
	NAR Establishment Charge, Per Occasion			UEP95	URECA	0.00							72.75							
<b>Additional Non-Recurring Charges (NRC)</b>																				
	Unbundled Miscellaneous Rate Element, Tag Loop at End Use Premise			UEP95	URETL								8.33	0.83						
	Unbundled Miscellaneous Rate Element, Tag Design Loop at End Use Premise			UEP95	URETN								11.21	1.10						
<b>UNE-P CENTREX - DMS100 (Valid in All States)</b>																				
<b>2-Wire VG Loop/2-Wire Voice Grade Port (Centrex) Combo</b>																				
<b>UNE Port/Loop Combination Rates (Non-Design)</b>																				
	2-Wire VG Loop/2-Wire Voice Grade Port (Centrex) Port Combo - Non-Design		1	UEP9D		10.79														
	2-Wire VG Loop/2-Wire Voice Grade Port (Centrex)Port Combo - Non-Design		2	UEP9D		15.52														
	2-Wire VG Loop/2-Wire Voice Grade Port (Centrex)Port Combo - Non-Design		3	UEP9D		31.74														
<b>UNE Port/Loop Combination Rates (Design)</b>																				
	2-Wire VG Loop/2-Wire Voice Grade Port (Centrex) Port Combo - Design		1	UEP9D		13.82														
	2-Wire VG Loop/2-Wire Voice Grade Port (Centrex)Port Combo - Design		2	UEP9D		18.60														
	2-Wire VG Loop/2-Wire Voice Grade Port (Centrex)Port Combo - Design		3	UEP9D		34.37														
<b>UNE Loop Rate</b>																				
	2-Wire Voice Grade Loop (SL 1) - Zone 1		1	UEP9D	UECS1	9.64														
	2-Wire Voice Grade Loop (SL 1) - Zone 2		2	UEP9D	UECS1	14.37														
	2-Wire Voice Grade Loop (SL 1) - Zone 3		3	UEP9D	UECS1	30.59														
	2-Wire Voice Grade Loop (SL 2) - Zone 1		1	UEP9D	UECS2	12.67														
	2-Wire Voice Grade Loop (SL 2) - Zone 2		2	UEP9D	UECS2	17.45														
	2-Wire Voice Grade Loop (SL 2) - Zone 3		3	UEP9D	UECS2	33.22														
<b>UNE Port Rate</b>																				
<b>ALL STATES</b>																				
	2-Wire Voice Grade Port (Centrex ) Basic Local Area			UEP9D	UEPYA	1.15							21.29	15.49	2.85	2.67				

UNBUNDLED NETWORK ELEMENTS - Kentucky																
CATEGORY	RATE ELEMENTS	Interim	Zone	BCS	USOC	RATES (\$)	Svc Order Submitted Elec per LSR	Svc Order Submitted Manually per LSR	Attachment: 2		Exhibit: A					
									Incremental Charge - Manual Svc Order vs. Electronic-1st	Incremental Charge - Manual Svc Order vs. Electronic-Add'l	Incremental Charge - Manual Svc Order vs. Electronic-Disc 1st	Incremental Charge - Manual Svc Order vs. Electronic-Disc Add'l				
									Rec	Nonrecurring		Nonrecurring Disconnect		OSS Rates (\$)		
						First	Add'l	First	Add'l	SOMEc	SOMAN	SOMAN	SOMAN	SOMAN	SOMAN	
	2-Wire Voice Grade Port (Centrex 800 termination)Basic Local Area			UEP9D	UEPYB	1.15	21.29	15.49	2.85	2.67						
	2-Wire Voice Grade Port (Centrex / EBS-PSET)3Basic Local Area			UEP9D	UEPYC	1.15	21.29	15.49	2.85	2.67						
	2-Wire Voice Grade Port (Centrex / EBS-M5009)3Basic Local Area			UEP9D	UEPYD	1.15	21.29	15.49	2.85	2.67						
	2-Wire Voice Grade Port (Centrex / EBS-M5209)3 Basic Local Area			UEP9D	UEPYE	1.15	21.29	15.49	2.85	2.67						
	2-Wire Voice Grade Port (Centrex / EBS-M5112)3 Basic Local Area			UEP9D	UEPYF	1.15	21.29	15.49	2.85	2.67						
	2-Wire Voice Grade Port (Centrex / EBS-M5312)3Basic Local Area			UEP9D	UEPYG	1.15	21.29	15.49	2.85	2.67						
	2-Wire Voice Grade Port (Centrex / EBS-M5008)3 Basic Local Area			UEP9D	UEPYT	1.15	21.29	15.49	2.85	2.67						
	2-Wire Voice Grade Port (Centrex / EBS-M5208)3 Basic Local Area			UEP9D	UEPYU	1.15	21.29	15.49	2.85	2.67						
	2-Wire Voice Grade Port (Centrex / EBS-M5216)3 Basic Local Area			UEP9D	UEPYV	1.15	21.29	15.49	2.85	2.67						
	2-Wire Voice Grade Port (Centrex / EBS-M5316)3 Basic Local Area			UEP9D	UEPY3	1.15	21.29	15.49	2.85	2.67						
	2-Wire Voice Grade Port (Centrex with Caller ID) Basic Local Area			UEP9D	UEPYH	1.15	21.29	15.49	2.85	2.67						
	2-Wire Voice Grade Port (Centrex/Caller ID/Msg Wtg Lamp Indication)4 Basic Local Area			UEP9D	UEPYW	1.15	21.29	15.49	2.85	2.67						
	2-Wire Voice Grade Port (Centrex/Msg Wtg Lamp Indication)4 Basic Local Area			UEP9D	UEPYJ	1.15	21.29	15.49	2.85	2.67						
	2-Wire Voice Grade Port (Centrex from diff Serving Wire Center) 2,3-Basic Local Area			UEP9D	UEPYM	1.15	21.29	15.49	2.85	2.67						
	2-Wire Voice Grade Port (Centrex/differ SWC /EBS-PSET)2,3,4 Basic Local Area			UEP9D	UEPYO	1.15	21.29	15.49	2.85	2.67						
	2-Wire Voice Grade Port (Centrex/differ SWC /EBS-M5009)2,3,4 Basic Local Area			UEP9D	UEPYP	1.15	21.29	15.49	2.85	2.67						
	2-Wire Voice Grade Port (Centrex/differ SWC /EBS-5209)2,3,4 Basic Local Area			UEP9D	UEPYQ	1.15	21.29	15.49	2.85	2.67						
	2-Wire Voice Grade Port (Centrex/differ SWC /EBS-M5112)2,3,4 Basic Local Area			UEP9D	UEPYR	1.15	21.29	15.49	2.85	2.67						
	2-Wire Voice Grade Port (Centrex/differ SWC /EBS-M5312)2,3,4 Basic Local Area			UEP9D	UEPYS	1.15	21.29	15.49	2.85	2.67						
	2-Wire Voice Grade Port (Centrex/differ SWC /EBS-M5008)2,3,4 Basic Local Area			UEP9D	UEPY4	1.15	21.29	15.49	2.85	2.67						
	2-Wire Voice Grade Port (Centrex/differ SWC /EBS-M5208)2, 3 Basic Local Area			UEP9D	UEPY5	1.15	21.29	15.49	2.85	2.67						
	2-Wire Voice Grade Port (Centrex/differ SWC /EBS-M5216)2,3,4 Basic Local Area			UEP9D	UEPY6	1.15	21.29	15.49	2.85	2.67						
	2-Wire Voice Grade Port (Centrex/differ SWC /EBS-M5316)2,3,4 Basic Local Area			UEP9D	UEPY7	1.15	21.29	15.49	2.85	2.67						
	2-Wire Voice Grade Port, Diff Serving Wire Center - 800 Service Term 2,3			UEP9D	UEPYZ	1.15	21.29	15.49	2.85	2.67						
	2-Wire Voice Grade Port terminated in on Megalink or equivalent Basic Local Area			UEP9D	UEPY9	1.15	21.29	15.49	2.85	2.67						
	2-Wire Voice Grade Port Terminated on 800 Service Term Basic Local Area			UEP9D	UEPY2	1.15	21.29	15.49	2.85	2.67						
<b>AL, KY, LA, MS, SC, &amp; TN Only</b>																
	2-Wire Voice Grade Port (Centrex)			UEP9D	UEPQA	1.15	21.29	15.49	2.85	2.67						
	2-Wire Voice Grade Port (Centrex 800 termination)			UEP9D	UEPQB	1.15	21.29	15.49	2.85	2.67						
	2-Wire Voice Grade Port (Centrex / EBS-PSET)4			UEP9D	UEPQC	1.15	21.29	15.49	2.85	2.67						
	2-Wire Voice Grade Port (Centrex / EBS-M5009)4			UEP9D	UEPQD	1.15	21.29	15.49	2.85	2.67						
	2-Wire Voice Grade Port (Centrex / EBS-M5209)4			UEP9D	UEPQE	1.15	21.29	15.49	2.85	2.67						
	2-Wire Voice Grade Port (Centrex / EBS-M5112)4			UEP9D	UEPQF	1.15	21.29	15.49	2.85	2.67						
	2-Wire Voice Grade Port (Centrex / EBS-M5312)4			UEP9D	UEPQG	1.15	21.29	15.49	2.85	2.67						
	2-Wire Voice Grade Port (Centrex / EBS-M5008)4			UEP9D	UEPQT	1.15	21.29	15.49	2.85	2.67						
	2-Wire Voice Grade Port (Centrex / EBS-M5208)4			UEP9D	UEPQU	1.15	21.29	15.49	2.85	2.67						



UNBUNDLED NETWORK ELEMENTS - Kentucky											Attachment: 2		Exhibit: A							
CATEGORY	RATE ELEMENTS	Interim	Zone	BCS	USOC	RATES (\$)	Svc Order Submitted Elec per LSR	Svc Order Submitted Manually per LSR	Incremental Charge - Manual Svc Order vs. Electronic-1st	Incremental Charge - Manual Svc Order vs. Electronic-Add'l	Incremental Charge - Manual Svc Order vs. Electronic-Disc 1st	Incremental Charge - Manual Svc Order vs. Electronic-Disc Add'l	OSS Rates (\$)							
													Rec	Nonrecurring		Nonrecurring Disconnect		SOME C	SOMAN	SOMAN
													First	Add'l	First	Add'l				
	2-Wire Voice Grade Port (Centrex / EBS-M5216)4			UEP9D	UEPQV	1.15		21.29	15.49	2.85	2.67									
	2-Wire Voice Grade Port (Centrex / EBS-M5316)4			UEP9D	UEPQ3	1.15		21.29	15.49	2.85	2.67									
	2-Wire Voice Grade Port (Centrex with Caller ID)			UEP9D	UEPQH	1.15		21.29	15.49	2.85	2.67									
	2-Wire Voice Grade Port (Centrex/Caller ID/Msg Wtg Lamp Indication)4			UEP9D	UEPQW	1.15		21.29	15.49	2.85	2.67									
	2-Wire Voice Grade Port (Centrex/Msg Wtg Lamp Indication)4			UEP9D	UEPQJ	1.15		21.29	15.49	2.85	2.67									
	2-Wire Voice Grade Port (Centrex from diff Serving Wire Center) 2,3			UEP9D	UEPQM	1.15		21.29	15.49	2.85	2.67									
	2-Wire Voice Grade Port (Centrex/differ SWC /EBS-PSET)2,3,4			UEP9D	UEPQO	1.15		21.29	15.49	2.85	2.67									
	2-Wire Voice Grade Port (Centrex/differ SWC /EBS-M5009)2,3,4			UEP9D	UEPQP	1.15		21.29	15.49	2.85	2.67									
	2-Wire Voice Grade Port (Centrex/differ SWC /EBS-5209)2,3,4			UEP9D	UEPQQ	1.15		21.29	15.49	2.85	2.67									
	2-Wire Voice Grade Port (Centrex/differ SWC /EBS-M5112)2,3,4			UEP9D	UEPQR	1.15		21.29	15.49	2.85	2.67									
	2-Wire Voice Grade Port (Centrex/differ SWC /EBS-M5312)2,3,4			UEP9D	UEPQS	1.15		21.29	15.49	2.85	2.67									
	2-Wire Voice Grade Port (Centrex/differ SWC /EBS-M5008)2,3,4			UEP9D	UEPQ4	1.15		21.29	15.49	2.85	2.67									
	2-Wire Voice Grade Port (Centrex/differ SWC /EBS-M5208)2,3,4			UEP9D	UEPQ5	1.15		21.29	15.49	2.85	2.67									
	2-Wire Voice Grade Port (Centrex/differ SWC /EBS-M5216)2,3,4			UEP9D	UEPQ6	1.15		21.29	15.49	2.85	2.67									
	2-Wire Voice Grade Port (Centrex/differ SWC /EBS-M5316)2,3,4			UEP9D	UEPQ7	1.15		21.29	15.49	2.85	2.67									
	2-Wire Voice Grade Port, Diff Serving Wire Center - 800 Service Term 2,3			UEP9D	UEPQZ	1.15		21.29	15.49	2.85	2.67									
	2-Wire Voice Grade Port terminated in on Megalink or equivalent			UEP9D	UEPQ9	1.15		21.29	15.49	2.85	2.67									
	2-Wire Voice Grade Port Terminated on 800 Service Term			UEP9D	UEPQ2	1.15		21.29	15.49	2.85	2.67									
	<b>Local Switching</b>																			
	Centrex Intercom Funtionality, per port			UEP9D	URECS	0.8873														
	<b>Local Number Portability</b>																			
	Local Number Portability (1 per port)			UEP9D	LNPC	0.35														
	<b>Features</b>																			
	All Standard Features Offered, per port			UEP9D	UEPVF	0.00														
	All Select Features Offered, per port			UEP9D	UEPVS	0.00		405.66												
	All Centrex Control Features Offered, per port			UEP9D	UEPVC	0.00														
	<b>NARS</b>																			
	Unbundled Network Access Register - Combination			UEP9D	UARCX	0.00		0.00	0.00	0.00	0.00									
	Unbundled Network Access Register - Inward			UEP9D	UAR1X	0.00		0.00	0.00	0.00	0.00									
	Unbundled Network Access Register - Outdial			UEP9D	UAROX	0.00		0.00	0.00	0.00	0.00									
	<b>Miscellaneous Terminations</b>																			
	<b>2-Wire Trunk Side</b>																			
	Trunk Side Terminations, each			UEP9D	CEND6	10.51		92.18	15.82	52.16	5.30									
	<b>4-Wire Digital (1.544 Megabits)</b>																			
	DS1 Circuit Terminations, each			UEP9D	M1HD1	74.77		164.86	77.74	60.69	3.86									
	DS0 Channels Activated per Channel			UEP9D	M1HDO	0.00		15.09												
	<b>Interoffice Channel Mileage - 2-Wire</b>																			
	Interoffice Channel Facilities Termination			UEP9D	M1GBC	29.11														
	Interoffice Channel mileage, per mile or fraction of mile			UEP9D	M1GBM	0.01														
	<b>Feature Activations (DS0) Centrex Loops on Channelized DS1 Service</b>																			
	<b>D4 Channel Bank Feature Activations</b>																			
	Feature Activation on D-4 Channel Bank Centrex Loop Slot			UEP9D	1PQWS	0.62														
	Feature Activation on D-4 Channel Bank FX line Side Loop Slot			UEP9D	1PQW6	0.62														
	Feature Activation on D-4 Channel Bank FX Trunk Side Loop Slot			UEP9D	1PQW7	0.62														
	Feature Activation on D-4 Channel Bank Centrex Loop Slot - Different Wire Center			UEP9D	1PQWP	0.62														
	Feature Activation on D-4 Channel Bank Private Line Loop Slot			UEP9D	1PQWV	0.62														
	Feature Activation on D-4 Channel Bank Tjje Line/Trunk Loop Slot			UEP9D	1PQWQ	0.62														
	Feature Activation on D-4 Channel Bank WATS Loop Slot			UEP9D	1PQWA	0.62														

UNBUNDLED NETWORK ELEMENTS - Kentucky														Attachment: 2		Exhibit: A				
CATEGORY	RATE ELEMENTS	Interim	Zone	BCS	USOC	RATES (\$)	Svc Order Submitted Elec per LSR	Svc Order Submitted Manually per LSR	Incremental Charge - Manual Svc Order vs. Electronic-1st	Incremental Charge - Manual Svc Order vs. Electronic-Add'l	Incremental Charge - Manual Svc Order vs. Electronic-Disc 1st	Incremental Charge - Manual Svc Order vs. Electronic-Disc Add'l	OSS Rates (\$)							
													Rec	Nonrecurring		Nonrecurring Disconnect		SOMEc	SOMAN	SOMAN
													First	Add'l	First	Add'l				
<b>Non-Recurring Charges (NRC) Associated with UNE-P Centrex</b>																				
	NRC Conversion Currently Combined Switch-As-Is with allowed changes, per port			UEP9D	USAC2	0.102		0.102												
	Conversion of existing Centrex Common Block, each			UEP9D	USACN	18.95		8.32												
	New Centrex Standard Common Block			UEP9D	M1ACS	0.00	669.80	78.32	111.05	13.27										
	New Centrex Customized Common Block			UEP9D	M1ACC	0.00	669.80	78.32	111.05	13.27										
	NAR Establishment Charge, Per Occasion			UEP9D	URECA	0.00	72.75													
<b>Additional Non-Recurring Charges (NRC)</b>																				
	Unbundled Miscellaneous Rate Element, Tag Loop at End Use Premise			UEP9D	URETL	8.33		0.83												
	Unbundled Miscellaneous Rate Element, Tag Design Loop at End Use Premise			UEP9D	URETN	11.21		1.10												
<b>UNE-P CENTREX - EWSD (Valid in AL, FL, KY, LA, MS &amp; TN)</b>																				
<b>2-Wire VG Loop/2-Wire Voice Grade Port (Centrex) Combo</b>																				
<b>UNE Port/Loop Combination Rates (Non-Design)</b>																				
	2-Wire VG Loop/2-Wire Voice Grade Port (Centrex) Port Combo - Non-Design		1	UEP9E		10.79														
	2-Wire VG Loop/2-Wire Voice Grade Port (Centrex)Port Combo - Non-Design		2	UEP9E		15.52														
	2-Wire VG Loop/2-Wire Voice Grade Port (Centrex)Port Combo - Non-Design		3	UEP9E		31.74														
<b>UNE Port/Loop Combination Rates (Design)</b>																				
	2-Wire VG Loop/2-Wire Voice Grade Port (Centrex) Port Combo - Design		1	UEP9E		13.82														
	2-Wire VG Loop/2-Wire Voice Grade Port (Centrex)Port Combo - Design		2	UEP9E		18.60														
	2-Wire VG Loop/2-Wire Voice Grade Port (Centrex)Port Combo - Design		3	UEP9E		34.37														
<b>UNE Loop Rate</b>																				
	2-Wire Voice Grade Loop (SL 1) - Zone 1		1	UEP9E	UECS1	9.64														
	2-Wire Voice Grade Loop (SL 1) - Zone 2		2	UEP9E	UECS1	14.37														
	2-Wire Voice Grade Loop (SL 1) - Zone 3		3	UEP9E	UECS1	30.59														
	2-Wire Voice Grade Loop (SL 2) - Zone 1		1	UEP9E	UECS2	12.67														
	2-Wire Voice Grade Loop (SL 2) - Zone 2		2	UEP9E	UECS2	17.45														
	2-Wire Voice Grade Loop (SL 2) - Zone 3		3	UEP9E	UECS2	33.22														
<b>UNE Port Rate</b>																				
<b>AL, FL, KY, LA, MS, &amp; TN only</b>																				
	2-Wire Voice Grade Port (Centrex ) Basic Local Area			UEP9E	UEPYA	1.15	21.29	15.49	2.85	2.67										
	2-Wire Voice Grade Port (Centrex 800 termination)Basic Local Area			UEP9E	UEPYB	1.15	21.29	15.49	2.85	2.67										
	2-Wire Voice Grade Port (Centrex with Caller ID)1Basic Local Area			UEP9E	UEPYH	1.15	21.29	15.49	2.85	2.67										
	2-Wire Voice Grade Port (Centrex from diff Serving Wire Center)2,3 Basic Local Area			UEP9E	UEPYM	1.15	21.29	15.49	2.85	2.67										
	2-Wire Voice Grade Port, Diff Serving Wire Center 2,3 - 800 Service Term - Basic Local Area			UEP9E	UEPYZ	1.15	21.29	15.49	2.85	2.67										
	2-Wire Voice Grade Port terminated in on Megalink or equivalent - Basic Local Area			UEP9E	UEPY9	1.15	21.29	15.49	2.85	2.67										
	2-Wire Voice Grade Port Terminated on 800 Service Term - Basic Local Area			UEP9E	UEPY2	1.15	21.29	15.49	2.85	2.67										
<b>AL, KY, LA, MS, &amp; TN Only</b>																				
	2-Wire Voice Grade Port (Centrex )			UEP9E	UEPQA	1.15	21.29	15.49	2.85	2.67										
	2-Wire Voice Grade Port (Centrex 800 termination)			UEP9E	UEPQB	1.15	21.29	15.49	2.85	2.67										
	2-Wire Voice Grade Port (Centrex with Caller ID)1			UEP9E	UEPQH	1.15	21.29	15.49	2.85	2.67										
	2-Wire Voice Grade Port (Centrex from diff Serving Wire Center)2,3			UEP9E	UEPQM	1.15	21.29	15.49	2.85	2.67										
	2-Wire Voice Grade Port, Diff Serving Wire Center 2,3 - 800 Service Term			UEP9E	UEPQZ	1.15	21.29	15.49	2.85	2.67										
	2-Wire Voice Grade Port terminated in on Megalink or equivalent			UEP9E	UEPQ9	1.15	21.29	15.49	2.85	2.67										
	2-Wire Voice Grade Port Terminated on 800 Service Term			UEP9E	UEPQ2	1.15	21.29	15.49	2.85	2.67										
<b>Local Switching</b>																				

UNBUNDLED NETWORK ELEMENTS - Kentucky														Attachment: 2		Exhibit: A				
CATEGORY	RATE ELEMENTS	Interim	Zone	BCS	USOC	RATES (\$)	Svc Order Submitted Elec per LSR	Svc Order Submitted Manually per LSR	Incremental Charge - Manual Svc Order vs. Electronic-1st	Incremental Charge - Manual Svc Order vs. Electronic-Add'l	Incremental Charge - Manual Svc Order vs. Electronic-Disc 1st	Incremental Charge - Manual Svc Order vs. Electronic-Disc Add'l	OSS Rates (\$)							
													Rec	Nonrecurring		Nonrecurring Disconnect		SOME	SOMAN	SOMAN
													First	Add'l	First	Add'l				
	Centrex Intercom Functionality, per port			UEP9E	URECS	0.8873														
	<b>Local Number Portability</b>																			
	Local Number Portability (1 per port)			UEP9E	LNPCC	0.35														
	<b>Features</b>																			
	All Standard Features Offered, per port			UEP9E	UEPVF	0.00														
	All Select Features Offered, per port			UEP9E	UEPVS	0.00	405.66													
	All Centrex Control Features Offered, per port			UEP9E	UEPVC	0.00														
	<b>NARS</b>																			
	Unbundled Network Access Register - Combination			UEP9E	UARCX	0.00	0.00	0.00	0.00	0.00										
	Unbundled Network Access Register - Indial			UEP9E	UAR1X	0.00	0.00	0.00	0.00	0.00										
	Unbundled Network Access Register - Outdial			UEP9E	UAROY	0.00	0.00	0.00	0.00	0.00										
	<b>Miscellaneous Terminations</b>																			
	<b>2-Wire Trunk Side</b>																			
	Trunk Side Terminations, each			UEP9E	CEND6	10.51	92.18	15.82	52.16	5.30										
	<b>4-Wire Digital (1.544 Megabits)</b>																			
	DS1 Circuit Terminations, each			UEP9E	M1HD1	74.77	164.86	77.74	60.69	3.86										
	DS0 Channel Activated Per Channel			UEP9E	M1HDO	0.00	15.09													
	<b>Interoffice Channel Mileage - 2-Wire</b>																			
	Interoffice Channel Facilities Termination			UEP9E	M1GBC	29.11														
	Interoffice Channel mileage, per mile or fraction of mile			UEP9E	M1GBM	0.01														
	<b>Feature Activations (DS0) Centrex Loops on Channelized DS1 Service</b>																			
	<b>D4 Channel Bank Feature Activations</b>																			
	Feature Activation on D-4 Channel Bank Centrex Loop Slot			UEP9E	1PQWS	0.62														
	Feature Activation on D-4 Channel Bank FX line Side Loop Slot			UEP9E	1PQW6	0.62														
	Feature Activation on D-4 Channel Bank FX Trunk Side Loop Slot			UEP9E	1PQW7	0.62														
	Feature Activation on D-4 Channel Bank Centrex Loop Slot - Different Wire Center			UEP9E	1PQWP	0.62														
	Feature Activation on D-4 Channel Bank Private Line Loop Slot			UEP9E	1PQWV	0.62														
	Feature Activation on D-4 Channel Bank Tjje Line/Trunk Loop Slot			UEP9E	1PQWQ	0.62														
	Feature Activation on D-4 Channel Bank WATS Loop Slot			UEP9E	1PQWA	0.62														
	<b>Non-Recurring Charges (NRC) Associated with UNE-P Centrex</b>																			
	NRC Conversion Currently Combined Switch-As-Is with allowed changes, per port			UEP9E	USAC2		0.102	0.102												
	Conversion of Existing Centrex Common Block, each			UEP9E	USACN		18.95	8.32												
	New Centrex Standard Common Block			UEP9E	M1ACS	0.00	669.80	78.32	111.05	13.27										
	New Centrex Customized Common Block			UEP9E	M1ACC	0.00	669.80	78.32	111.05	13.27										
	NAR Establishment Charge, Per Occasion			UEP9E	URECA	0.00	72.75													
	<b>Additional Non-Recurring Charges (NRC)</b>																			
	Unbundled Miscellaneous Rate Element, Tag Loop at End Use Premise			UEP9E	URETL		8.33	0.83												
	Unbundled Miscellaneous Rate Element, Tag Design Loop at End Use Premise			UEP9E	URETN		11.21	1.10												
	<b>UNE-P CENTREX - DCO - Valid in AL, KY, LA, MS, &amp; TN</b>																			
	<b>2-Wire VG Loop/2-Wire Voice Grade Port (Centrex) Combo</b>																			
	<b>UNE Port/Loop Combination Rates (Non-Design)</b>																			
	2-Wire VG Loop/2-Wire Voice Grade Port (Centrex) Port Combo - Non-Design		1	UEP93		10.79														
	2-Wire VG Loop/2-Wire Voice Grade Port (Centrex)Port Combo - Non-Design		2	UEP93		15.52														
	2-Wire VG Loop/2-Wire Voice Grade Port (Centrex)Port Combo - Non-Design		3	UEP93		31.74														
	<b>UNE Port/Loop Combination Rates (Design)</b>																			
	2-Wire VG Loop/2-Wire Voice Grade Port (Centrex) Port Combo - Design		1	UEP93		13.82														
	2-Wire VG Loop/2-Wire Voice Grade Port (Centrex)Port Combo - Design		2	UEP93		18.60														
	2-Wire VG Loop/2-Wire Voice Grade Port (Centrex)Port Combo - Design		3	UEP93		34.37														
	<b>UNE Loop Rate</b>																			
	2-Wire Voice Grade Loop (SL 1) - Zone 1		1	UEP93	UECS1	9.64														

UNBUNDLED NETWORK ELEMENTS - Kentucky														Attachment: 2		Exhibit: A				
CATEGORY	RATE ELEMENTS	Interim	Zone	BCS	USOC	RATES (\$)	Svc Order Submitted Elec per LSR	Svc Order Submitted Manually per LSR	Incremental Charge - Manual Svc Order vs. Electronic-1st	Incremental Charge - Manual Svc Order vs. Electronic-Add'l	Incremental Charge - Manual Svc Order vs. Electronic-Disc 1st	Incremental Charge - Manual Svc Order vs. Electronic-Disc Add'l	OSS Rates (\$)							
													Rec	Nonrecurring		Nonrecurring Disconnect		SOMECE	SOMAN	SOMAN
													First	Add'l	First	Add'l				
	2-Wire Voice Grade Loop (SL 1) - Zone 2		2	UEP93	UECS1	14.37														
	2-Wire Voice Grade Loop (SL 1) - Zone 3		3	UEP93	UECS1	30.59														
	2-Wire Voice Grade Loop (SL 2) - Zone 1		1	UEP93	UECS2	12.67														
	2-Wire Voice Grade Loop (SL 2) - Zone 2		2	UEP93	UECS2	17.45														
	2-Wire Voice Grade Loop (SL 2) - Zone 3		3	UEP93	UECS2	33.22														
<b>UNE Port Rate</b>																				
<b>AL, KY, LA, MS, &amp; TN only</b>																				
	2-Wire Voice Grade Port (Centrex ) Basic Local Area			UEP93	UEPYA	1.15	21.29	15.49	2.85	2.67										
	2-Wire Voice Grade Port (Centrex 800 termination)Basic Local Area			UEP93	UEPYB	1.15	21.29	15.49	2.85	2.67										
	2-Wire Voice Grade Port (Centrex with Caller ID)1Basic Local Area			UEP93	UEPYH	1.15	21.29	15.49	2.85	2.67										
	2-Wire Voice Grade Port (Centrex from diff Serving Wire Center)2,3 Basic Local Area			UEP93	UEPYM	1.15	21.29	15.49	2.85	2.67										
	2-Wire Voice Grade Port, Diff Serving Wire Center - 2,3 - 800 Service Term - Basic Local Area			UEP93	UEPYZ	1.15	21.29	15.49	2.85	2.67										
	2-Wire Voice Grade Port terminated in on Megalink or equivalent - Basic Local Area			UEP93	UEPY9	1.15	21.29	15.49	2.85	2.67										
	2-Wire Voice Grade Port Terminated on 800 Service Term - Basic Local Area			UEP93	UEPY2	1.15	21.29	15.49	2.85	2.67										
	2-Wire Voice Grade Port (Centrex )			UEP93	UEPQA	1.15	21.29	15.49	2.85	2.67										
	2-Wire Voice Grade Port (Centrex 800 termination)			UEP93	UEPQB	1.15	21.29	15.49	2.85	2.67										
	2-Wire Voice Grade Port (Centrex with Caller ID)1			UEP93	UEPQH	1.15	21.29	15.49	2.85	2.67										
	2-Wire Voice Grade Port (Centrex from diff Serving Wire Center)2,3			UEP93	UEPQM	1.15	21.29	15.49	2.85	2.67										
	2-Wire Voice Grade Port, Diff Serving Wire Center - 2,3 -800 Service Term			UEP93	UEPQZ	1.15	21.29	15.49	2.85	2.67										
	2-Wire Voice Grade Port terminated in on Megalink or equivalent			UEP93	UEPQ9	1.15	21.29	15.49	2.85	2.67										
	2-Wire Voice Grade Port Terminated on 800 Service Term			UEP93	UEPQ2	1.15	21.29	15.49	2.85	2.67										
<b>Local Switching</b>																				
	Centrex Intercom Functionality, per port			UEP93	URECS	0.8873														
<b>Local Number Portability</b>																				
	Local Number Portability (1 per port)			UEP93	LNPC	0.35														
<b>Features</b>																				
	All Standard Features Offered, per port			UEP93	UEPVF	0.00														
	All Centrex Control Features Offered, per port			UEP93	UEPVC	0.00														
<b>NARS</b>																				
	Unbundled Network Access Register - Combination			UEP93	UARCX	0.00	0.00	0.00	0.00	0.00										
	Unbundled Network Access Register - Indial			UEP93	UAR1X	0.00	0.00	0.00	0.00	0.00										
	Unbundled Network Access Register - Outdial			UEP93	UAROX	0.00	0.00	0.00	0.00	0.00										
<b>Miscellaneous Terminations</b>																				
<b>2-Wire Trunk Side</b>																				
	Trunk Side Terminations, each			UEP93	CEND6	10.51	92.18	15.82	52.16	5.30										
<b>4-Wire Digital (1.544 Megabits)</b>																				
	DS1 Circuit Terminations, each			UEP93	M1HD1	74.77	164.86	77.74	60.69	3.86										
	DS0 Channels Activated, Per Channel			UEP93	M1HDO	0.00	15.09													
<b>Interoffice Channel Mileage - 2-Wire</b>																				
	Interoffice Channel Facilities Termination			UEP93	M1GBC	29.11														
	Interoffice Channel mileage, per mile or fraction of mile			UEP93	M1GBM	0.01														
<b>Feature Activations (DS0) Centrex Loops on Channelized DS1 Service</b>																				
<b>D4 Channel Bank Feature Activations</b>																				
	Feature Activation on D-4 Channel Bank Centrex Loop Slot			UEP93	1PQWS	0.62														
	Feature Activation on D-4 Channel Bank FX Line Side Loop Slot			UEP93	1PQW6	0.62														
	Feature Activation on D-4 Channel Bank FX Trunk Side Loop Slot			UEP93	1PQW7	0.62														
	Feature Activation on D-4 Channel Bank Centrex Loop Slot - Different Wire Center			UEP93	1PQWP	0.62														
	Feature Activation on D-4 Channel Bank Private Line Loop Slot			UEP93	1PQWV	0.62														
	Feature Activation on D-4 Channel Bank Tie Line/Trunk Loop Slot			UEP93	1PQWQ	0.62														
	Feature Activation on D-4 Channel Bank WATS Loop Slot			UEP93	1PQWA	0.62														

UNBUNDLED NETWORK ELEMENTS - Kentucky																
CATEGORY	RATE ELEMENTS	Interim	Zone	BCS	USOC	RATES (\$)	Svc Order Submitted Elec per LSR	Svc Order Submitted Manually per LSR	Attachment: 2		Exhibit: A					
									Incremental Charge - Manual Svc Order vs. Electronic-1st	Incremental Charge - Manual Svc Order vs. Electronic-Add'l	Incremental Charge - Manual Svc Order vs. Electronic-Disc 1st	Incremental Charge - Manual Svc Order vs. Electronic-Disc Add'l				
									Rec	Nonrecurring		Nonrecurring Disconnect		OSS Rates (\$)		
						First	Add'l	First	Add'l	SOMEc	SOMAN	SOMAN	SOMAN	SOMAN	SOMAN	
	<b>Non-Recurring Charges (NRC) Associated with UNE-P Centrex</b>															
	NRC Conversion Currently Combined Switch-As-Is with allowed changes, per port			UEP93	USAC2	0.102	0.102									
	Conversion of Existing Centrex Common Block, each			UEP93	USACN	18.95	8.32									
	New Centrex Standard Common Block			UEP93	M1ACS	0.00	669.80	78.32	111.05	13.27						
	New Centrex Customized Common Block			UEP93	M1ACC	0.00	669.80	78.32	111.05	13.27						
	NAR Establishment Charge, Per Occasion			UEP93	URECA	0.00	72.75									
	<b>Additional Non-Recurring Charges (NRC)</b>															
	Unbundled Miscellaneous Rate Element, Tag Loop at End Use Premise			UEP93	URETL	8.33	0.83									
	Unbundled Miscellaneous Rate Element, Tag Design Loop at End Use Premise			UEP93	URETN	11.21	1.10									
	<b>Note 1 - Required Port for Centrex Control in 1AESS, 5ESS &amp; EWSD</b>															
	<b>Note 2 - Requires Interoffice Channel Mileage</b>															
	<b>Note 3 - Installation is combination of Installation charge for SL2 Loop and Port</b>															
	<b>Note 4 - Requires Specific Customer Premises Equipment</b>															
	<b>Note: Rates displaying an "R" in Interim column are interim and subject to rate true-up as set forth in General Terms and Conditions.</b>															

**Attachment 3**  
**Network Interconnection**

## TABLE OF CONTENTS

<b>1. GENERAL.....</b>	<b>3</b>
<b>2. DEFINITIONS: (FOR THE PURPOSE OF THIS ATTACHMENT) .....</b>	<b>3</b>
<b>3. NETWORK INTERCONNECTION .....</b>	<b>5</b>
<b>4. INTERCONNECTION TRUNK GROUP ARCHITECTURES.....</b>	<b>9</b>
<b>5. NETWORK DESIGN AND MANAGEMENT FOR INTERCONNECTION .....</b>	<b>16</b>
<b>6. SIGNALING.....</b>	<b>17</b>
<b>7. FORECASTING FOR TRUNK PROVISIONING .....</b>	<b>26</b>
<b>8. TRUNK UTILIZATION .....</b>	<b>27</b>
<b>9. INTERFERENCE OR IMPAIRMENT .....</b>	<b>29</b>
<b>10. COMPENSATION FOR CALL TRANSPORTATION AND TERMINATION FOR LOCAL TRAFFIC AND ISP-BOUND TRAFFIC .....</b>	<b>31</b>
<b>11. FRAME RELAY SERVICE INTERCONNECTION.....</b>	<b>41</b>
<b>12. BASIC 911 AND E911 INTERCONNECTION.....</b>	<b>44</b>
<b>Rates</b>	<b>Exhibit A</b>
<b>Basic Architecture</b>	<b>Exhibit B</b>
<b>One Way Architecture</b>	<b>Exhibit C</b>
<b>Two Way Architecture</b>	<b>Exhibit D</b>
<b>Supergroup Architecture</b>	<b>Exhibit E</b>

## NETWORK INTERCONNECTION

### 1. GENERAL

- 1.1 The Parties shall provide interconnection with each other's networks for the transmission and routing of telephone exchange service (Local Traffic), ISP-bound Traffic, and exchange access (Switched Access Traffic) on the following terms:

### 2. DEFINITIONS: (FOR THE PURPOSE OF THIS ATTACHMENT)

For purposes of this attachment only, the following terms shall have the definitions set forth below:

- 2.1 **Automatic Location Identification (ALI)** is a feature by which the address associated with the calling party's telephone number (ANI) is forwarded to the PSAP for display. Access to the ALI database is described in Attachment 2 to this Agreement.
- 2.2 **Automatic Number Identification (ANI)** corresponds to the seven-digit telephone number assigned by the serving local exchange carrier.
- 2.3 **Basic 911 Service (B911)** routes a call to one centralized answering location. The attendant at the answering location obtains the pertinent information that identifies the call and the caller's needs. The attendant then determines the appropriate agency and dials a 7-digit number to transfer the caller to that agency. The calling party's emergency information is verbally relayed to the responding agency and a unit is dispatched to the caller's location.
- 2.4 **Call Termination** has the meaning set forth for "termination" in 47CFR § 51.701(d).
- 2.5 **Call Transport** has the meaning set forth for "transport" in 47 CFR § 51.701(c).
- 2.6 **Call Transport and Termination** is used collectively to mean the switching and transport functions from the Interconnection Point to the last point of switching.
- 2.7 **Common (Shared) Transport** is defined as the transport of the originating Party's traffic by the terminating Party over the terminating Party's common (shared) facilities between (1) the terminating Party's tandem switch and end office switch, (2) between the terminating Party's tandem switches, and/or (3) between the terminating Party's host and remote end office switches. All switches referred herein must be entered into the Local Exchange Routing Guide (LERG).
- 2.8 **Cross Connect** is as defined in Attachment 4 of the Interconnection Agreement. If a Party provisions a cross connect for the purposes of interconnection under



this Attachment 3, and such cross connect is not associated with a physical or virtual collocation arrangement, the provisioning party shall not charge for such cross connect.

- 2.9 **Dedicated Interoffice Facility** is defined as a switch transport facility between a Party's Serving Wire Center and the first point of switching within the LATA on the other Party's network.
- 2.10 **End Office Switching** is defined as the function that establishes a communications path between the trunk side and line side of the End Office switch.
- 2.11 **Enhanced 911 Service** provides features not present in Basic 911 Service, including ANI and ALI display, Selective Routing (SR) and other standard and optional features.
- 2.12 **Fiber Meet** is an interconnection arrangement whereby the Parties physically interconnect their networks via an optical fiber interface at which one Party's facilities, provisioning, and maintenance responsibility begins and the other Party's responsibility ends.
- 2.13 **Interconnection Point (IP)** is the physical telecommunications equipment interface that interconnects the networks of BellSouth and KMC.
- 2.14 **IntraLATA Toll Traffic** does not exist for purposes of this Agreement, as the Parties have agreed upon a LATA-wide Local Traffic definition.
- 2.15 **ISP-bound Traffic** is defined as a call to an information service provider/enhanced service provider or Internet Service Provider ("ISP") that is dialed by using a local dialing pattern (7 or 10 digits).
- 2.16 **Local Channel** is defined as a switched transport facility between a Party's Point of Presence and its designated Serving Wire center where the POP is not located in the designated Serving Wire Center.
- 2.17 **Local Traffic** is as defined any circuit switched call that is originated by an end user of one Party and terminated to an end user of the other Party within a given LATA on that other Party's network, except for those calls that are originated or terminated through switched access arrangements as established by applicable FCC and Commissions rules and orders.
- 2.18 **Point of Presence (POP)** is the physical location at which a Party establishes itself for obtaining access to the other Party's network.
- 2.19 **Public Safety Answering Point (PSAP)** is the answering location for 911 calls.

- 2.20 **Reciprocal Trunk Group** is defined as a one-way trunk group carrying BellSouth originated traffic to be terminated by KMC.
- 2.21 **Serving Wire Center** is defined as the first, or only, wire center (such as a tandem or an end office) owned, or leased by one Party that is designated by that Party to serve the geographic area in which the other Party's POP is located and to which the other Party's facilities are connected (i.e. interconnected or transverses/passes through) for the purposes of interconnection.
- 2.22 **Selective Routing (SR)** is a standard feature that routes an E911 call from the tandem to the designated PSAP based upon the address of the ANI of the calling party.
- 2.23 **Tandem Switching** is defined as the function that establishes a communications path between two switching offices through a third switching office through the provision of trunk side to trunk side switching.
- 2.23.1 Consistent with FCC rules and orders, a KMC switch shall be considered a tandem switch if it serves a geographic area comparable, but not necessarily identical, to that served by the relevant BellSouth tandem switch. KMC shall provide to BellSouth supporting data to show such geographic comparability and if the Parties are unable to agree then the issue shall be resolved pursuant to the Dispute Resolution process set forth in the General Terms and Conditions of this Agreement.
- 2.24 **Transit Traffic** is traffic originating on one Party's network that is switched and/or transported by the other Party and delivered to a third party's network, or traffic originating on a third party's network that is switched and/or transported by one Party and delivered to the other Party's network.

### 3. NETWORK INTERCONNECTION

- 3.1 This Attachment pertains only to the provision of network interconnection where KMC owns, leases from a third party or otherwise provides its own switch(es).
- 3.2 Network interconnection may be provided by the Parties at any technically feasible point within BellSouth's network in accordance with applicable FCC and Commission Rules and Orders. In accordance with the terms of this Agreement, network interconnection may be provided via a DS0 where technically feasible and supported by applicable industry standards. Requests for interconnection via methods, such as OCn level interconnection, other than as set forth in this Attachment may be made through the Bona Fide Request (BFR) process set out in Attachment 11 to this Agreement.
- 3.2.1 Each Party is responsible for providing, engineering and maintaining the network on its side of the IP. The IP must be located within BellSouth's serving territory in the LATA in which traffic is originating. The IP determines the point at which

the originating Party shall pay the terminating Party for the Call Transport and Termination of Local Traffic, and ISP-bound Traffic.

3.2.2 Pursuant to the provisions of this Attachment, the location of the initial IP in a given LATA shall be established by mutual agreement of the Parties. Subject to the requirements for installing additional IPs, as set forth below, any IPs existing prior to the Effective Date of the Agreement will be accepted as initial IPs and BellSouth will not require re-grooming, however, KMC may augment and regroom such IP(s). When the Parties mutually agree to utilize two-way interconnection trunk groups for the exchange of Local Traffic, ISP-bound Traffic and between each other, the Parties shall mutually agree to the location of the IP. Notwithstanding the foregoing, if the Parties are unable to agree to a mutual initial IP, each Party, as originating Party, shall establish a single IP in the LATA for the delivery of its originated Local Traffic, ISP-bound Traffic and to the other Party for Call Transport and Termination by the terminating Party.

3.2.3 When first establishing the interconnection arrangement in each LATA, the location of the IP shall be established by mutual agreement of the Parties. In selecting the IP, both Parties will act in good faith and select the point that is most efficient for both Parties. If the Parties are unable to agree on the location of the IP, each Party will designate IPs for its originated traffic. Additional IP(s) in a LATA may be established by mutual agreement of the Parties. In selecting additional IP(s) both Parties will act in good faith and shall consider points that are efficient for both Parties. Notwithstanding the foregoing, and unless mutually agreed to otherwise, additional IP(s) in a particular LATA shall be established, at the request of either Party, when the following criteria are satisfied: (1) the Local Traffic and ISP-bound Traffic exceeds 8.9 million minutes per month for three consecutive months at the proposed location of the additional IP; and (2) any end office to be designated as an IP must be more than twenty (20) miles from an existing IP. BellSouth will not request the establishment of an IP where physical or virtual collocation space is not available or where BellSouth fiber connectivity is not available. When the Parties agree to utilize two-way interconnection trunk groups for the exchange of Local Traffic, ISP-bound Traffic and the Parties must agree to the location of the additional IP(s).

3.2.4 Upon written notification from the Party requesting the establishment of an additional IP, the receiving Party has twenty (20) business days to analyze, respond to, and negotiate in good faith regarding the establishment of such IP.

### 3.3 **Interconnection via Dedicated Facilities**

3.3.1 With the exception of Transit Traffic, the Parties shall institute a “bill and keep” compensation plan under which neither Party will charge the other Party recurring and nonrecurring charges for trunks (one-way or two-way), trunk ports and associated dedicated facilities for the exchange of Local Traffic (non-transit) and ISP-bound Traffic (non-transit) and 911 traffic. The appropriate rate elements

that are subject to this “bill and keep” compensation plan are set forth in Exhibit A to this Attachment. Each Party has the obligation to install and maintain the appropriate trunks, trunk ports and associated facilities on its respective side of the IP and is responsible for bearing its costs for such trunks, trunk ports and associated facilities on its side of the IP. Both Parties, as appropriate, shall be compensated for the ordering of trunks, trunk ports and facilities used exclusively for transit traffic and for ancillary traffic types including, but not limited to OS/DA. The Parties agree that charges for such trunks, trunk ports and facilities are as set forth in Exhibit A to this Attachment or to the extent a rate associated with the interconnecting trunk group is not set forth in Exhibit A, the rate shall be as set forth in the appropriate Party’s tariff as filed and effective with the FCC or Commission, or reasonable and non-discriminatory web-posted listing if the FCC or Commission does not require filing of a tariff.

3.3.2 **Local Channel Facilities.** In lieu of providing facilities on its side of Interconnection Point or as part of Call Transport and Termination, either Party may purchase Local Channel facilities from the other Party pursuant to the provisions of this Attachment, where such facilities are available. The percentage of Local Channel Facilities utilized for Local Traffic and ISP-bound Traffic shall be determined based upon the application of the Percent Local Facility (PLF) Factor on a statewide basis. The charges applied to the percentage of Local Channel facilities used for Local Traffic and ISP-bound Traffic as determined by the PLF are set forth in Section 3.3.1 above. The remaining percentage of Local Channel Facilities shall be billed at the appropriate Party’s intrastate or interstate tariff rates for switched access services or reasonable and non-discriminatory web-posted listing if the FCC or Commission does not require filing of a tariff.

3.3.3 **Dedicated Interoffice Facilities.** In lieu of providing facilities on its side of Interconnection Point or as part of Call Transport and Termination, either Party may purchase Dedicated Interoffice facilities from the other Party pursuant to the provisions of this Attachment, where such facilities are available. The percentage of Dedicated Interoffice Facilities utilized for Local Traffic and ISP-bound Traffic shall be determined based upon the application of the Percent Local Facility (PLF) Factor on a statewide basis. The charges applied to the percentage of Dedicated Interoffice facilities used for Local Traffic and ISP-bound Traffic as determined by the PLF are set forth in Section 3.3.1 above. The remaining percentage of the Dedicated Interoffice Facilities shall be billed at the appropriate Party’s intrastate or interstate tariff rates for switched access services or reasonable and non-discriminatory web-posted listing if the FCC or Commission does not require filing of a tariff.

3.3.4 [Parties Disagree]

**[KMC Version]** In the event that a Party's Point of Presence is located within any serving wire center (i.e., switch location), such Party may interconnect to the other Party's switch via a Cross Connect or any other technically feasible means of interconnection.

**[BellSouth Version]** If a Party provisions a cross connect for the purposes of interconnection under this Attachment 3, and such cross connect is not associated with a physical or virtual collocation arrangement, the provisioning party shall not charge for such cross connect.

3.3.5 The facilities and associated components as set forth in Exhibit A of this Attachment purchased pursuant to this Section 3 shall be ordered via the Access Service Request (ASR) process. The terms, conditions and rates for ordering charges (i.e., expedite, cancellation, and order modification charges) are as set forth in the BellSouth FCC Tariff No. 1. To the extent that BellSouth requests that <<customer\_short\_name>> submit an ASR for an augmentation to the facilities purchased by <<customer\_short\_name>> from BellSouth but utilized for BellSouth's originated traffic, the Parties will work in good faith and make best efforts to ensure that the ASR submitted for such augmentations does not require expedition, cancellation or modification and in the event that <<customer\_short\_name>> incurs ordering charges, BellSouth and <<customer\_short\_name>> shall work cooperatively to determine which Party caused the incurrence of such charges and that Party shall be responsible for such charges.

#### 3.4 **Fiber Meet**

3.4.1 Notwithstanding Section 3.2.1, 3.2.2, and 3.2.3 above, if KMC elects to establish interconnection with BellSouth pursuant to a Fiber Meet Local Channel, KMC and BellSouth shall jointly engineer, operate and maintain a Synchronous Optical Network (SONET) transmission system by which they shall interconnect their transmission and routing of Local Traffic via a Local Channel at either the DS1 or DS3 level. The Parties shall work jointly to determine the specific transmission system. However, KMC's SONET transmission system must be compatible with BellSouth's equipment, and the Data Communications Channel (DCC) must be turned off, unless otherwise mutually agreed to by the Parties.

3.4.2 Each Party, at its own expense, shall procure, install and maintain the agreed upon SONET transmission system in its network.

3.4.3 The Parties shall agree to a Fiber Meet point between the BellSouth Serving Wire Center and the KMC Serving Wire Center. The Parties shall deliver their fiber optic facilities to the Fiber Meet point with sufficient spare length to reach the fusion splice point for the Fiber Meet Point. BellSouth shall, at its own expense, provide and maintain the fusion splice point for the Fiber Meet. A building type Common Language Location Identification (CLLI) code will be established for

each Fiber Meet point. All orders for interconnection facilities from the Fiber Meet point shall indicate the Fiber Meet point as the originating point for the facility.

- 3.4.4 Upon verbal request by KMC, and within a reasonable and non-discriminatory time frame, BellSouth shall allow KMC access to the fusion splice point for the Fiber Meet point for maintenance purposes on KMC's side of the Fiber Meet point.
- 3.4.5 Neither Party shall charge the other for its Local Channel portion of the Fiber Meet facility used exclusively for Local Traffic and ISP-Bound Traffic. The remaining portion of the Local Channel shall be billed at the appropriate Party's intrastate or interstate tariff rates for switched access services or reasonable and non-discriminatory web-posted listing if the FCC or Commission does not require filing of a tariff.

#### **4. INTERCONNECTION TRUNK GROUP ARCHITECTURES**

- 4.1 BellSouth and KMC shall establish interconnecting trunk groups and trunk group configurations between networks, including the use of one-way or two-way trunks in accordance with the following provisions set forth in this Attachment. For trunking purposes, traffic will be routed based on the digits dialed by the originating End User and in accordance with the LERG.
- 4.2 Consistent with Section 3.2, 3.2.1, 3.2.2, and 3.3.3. KMC shall establish an interconnection trunk group(s) to at least one BellSouth access tandem within the LATA for the delivery of KMC's originated Local Traffic, ISP-bound Traffic and for the receipt and delivery of Transit Traffic. To the extent KMC desires to deliver Local Traffic, ISP-bound Traffic, and/or Transit Traffic to BellSouth access tandems within the LATA, other than the tandems(s) to which KMC has established interconnection trunk groups, KMC shall order Multiple Tandem Access, as described in this Attachment, to such other BellSouth access tandems.
- 4.2.1 Notwithstanding the forgoing, <<customer\_short\_name>> shall establish an interconnection trunk group(s) to all BellSouth access and local tandems in the LATA where <<customer\_short\_name>> has homed (i.e. assigned) its NPA/NXXs. <<customer\_short\_name>> shall home its NPA/NXXs on the BellSouth tandems that serve the exchange rate center areas to which the NPA/NXXs are assigned. The specified exchange rate center assigned to each BellSouth tandem is defined in the LERG. <<customer\_short\_name>> shall enter its NPA/NXX access and/or local tandem homing arrangements into the LERG.
- 4.3 Switched access traffic will be delivered to and from Interexchange Carriers (IXCs) based on KMC's NXX access tandem homing arrangement as specified by KMC in the LERG.

- 4.4 Any KMC interconnection request that (1) deviates from the interconnection trunk group architectures as described in this Attachment, (2) affects traffic delivered to KMC from a BellSouth switch, and (3) requires special BellSouth switch translations and other network modifications will require KMC to submit a BFR/NBR via the BFR/NBR Process as set forth in Attachment 11 of this Agreement. At such time that BellSouth submits a request for interconnection that meets the requirements of this section, the Parties will negotiate the rates, terms, and conditions for such request.
- 4.5 All trunk groups will be provisioned as Signaling System 7 (SS7) capable where technically feasible. If SS7 is not technically feasible multi-frequency (MF) protocol signaling shall be used.
- 4.6 In cases where KMC is also an IXC, the IXC's Feature Group D (FG D) trunk group(s) must remain separate from the local interconnection trunk group(s).
- 4.7 Each Party shall order interconnection trunks and trunk group including trunk and trunk group augmentations via the ASR process. A Firm Order Confirmation (FOC) shall be returned to the ordering Party, after receipt of a valid, error free ASR, within the timeframes set forth in each state's applicable Performance Measures. Notwithstanding the foregoing, blocking situations and projects shall be managed through BellSouth's Carrier Interconnection Switching Center (CISC) Project Management Group and KMC's equivalent trunking group, and FOCs for such orders shall be returned in the timeframes negotiated by the Parties and suitable to the project. No additional charges shall be triggered due to the involvement of such project management. A project is defined as (1) a new trunk group, excluding augments to existing routes or trunk groups already provided for pursuant to the terms of this Attachment or (2) a request for more than 96 trunks on a single or multiple group(s) in a given BellSouth local calling area.
- 4.8 **Interconnection Trunk Groups for Exchange of Local Traffic, ISP-Bound Traffic and Transit Traffic**
- Upon mutual agreement of the Parties in a joint planning meeting, the Parties' shall exchange Local Traffic, ISP-Bound Traffic, , and Transit Traffic, where applicable, on two-way interconnection trunk group(s) with the quantity of trunks being mutually determined and the provisioning being jointly coordinated. Furthermore, the Parties shall agree upon the IP(s) for two-way interconnection trunk groups transporting both Parties' Local Traffic, ISP-bound Traffic, and Transit Traffic, where applicable as set forth in Section 3 of this Attachment above. KMC shall order such two-way trunks via the Access Service Request (ASR) process. BellSouth will use the Trunk Group Service Request (TGSR) to request changes in trunking. Furthermore, the Parties shall jointly review trunk performance and forecasts on a periodic basis as set forth in section 7 of this Attachment. The Parties' use of two-way interconnection trunk groups for the transport of Local Traffic, ISP-bound Traffic, , and Transit Traffic between the Parties does not preclude either Party from establishing additional one-way

interconnection trunks for the delivery of its originated Local Traffic, ISP-bound Traffic, and , and Transit Traffic to the other Party.

#### 4.8.1 **BellSouth Access Tandem Interconnection**

BellSouth access tandem interconnection at a single access tandem provides access to those end offices subtending that access tandem (Intratandem Access). Access tandem interconnection is available for any of the following access tandem architectures

##### 4.8.1.1 **Basic Architecture**

In the basic architecture, KMC 's originating Local Traffic, ISP-bound Traffic and and originating and terminating Transit Traffic is transported on a single two-way trunk group between KMC and BellSouth access tandem(s) within a LATA to provide Intratandem Access. This trunk group carries Transit Traffic between KMC and Independent Companies, Interexchange Carriers, other CLECs, CMRS providers that have a Meet Point Billing arrangement with BellSouth, and other network providers with which KMC desires to exchange traffic. This trunk group also carries KMC originated Transit Traffic transiting a single BellSouth access tandem destined to third party tandems such as an Independent Company tandem or other CLEC tandem. BellSouth originated Local Traffic, ISP-bound Traffic and is transported on a separate single one-way trunk group terminating to KMC . Other trunk groups for operator services, directory assistance, emergency services and intercept may be established pursuant to the applicable BellSouth tariff if service is requested. The LERG contains current routing and tandem serving arrangements. The basic Architecture is illustrated in Exhibit B.

##### 4.8.1.2 **One-Way Trunk Group Architecture**

In one-way trunk group architecture, the Parties interconnect using three separate trunk groups. A one-way trunk group provides Intratandem Access for KMC – originated Local Traffic, ISP-bound Traffic and destined for BellSouth End Users. A second one-way trunk group carries BellSouth-originated Local Traffic, ISP-bound Traffic and destined for KMC End-Users. A two-way trunk group provides Intratandem Access for KMC 's originating and terminating Transit Traffic. This trunk group carries Transit Traffic between KMC and Independent Companies, Interexchange Carriers, other CLECs, CMRS providers that have a Meet Point Billing arrangement with BellSouth, and other network providers with which KMC desires to exchange traffic. This trunk group also carries KMC originated Transit Traffic transiting a single BellSouth access tandem destined to third party tandems such as an Independent Company tandem or other CLEC tandem. BellSouth originated Local Traffic, ISP-bound Traffic and is transported on a separate single one-way trunk group terminating to KMC . Other trunk groups for operator services, directory assistance, emergency services and intercept may be established pursuant to the applicable BellSouth tariff if service is requested. The LERG contains current routing and tandem serving arrangements. The one-way trunk group architecture is illustrated in Exhibit C.



#### 4.8.1.3 **Two-Way Trunk Group Architecture**

The two-way trunk group Architecture establishes one two-way trunk group to provide Intratandem Access for the exchange of Local Traffic, ISP-bound Traffic and between KMC and BellSouth. In addition, a separate two-way transit trunk group must be established for KMC 's originating and terminating Transit Traffic. This trunk group carries Transit Traffic between KMC and Independent Companies, Interexchange Carriers, other CLECs, CMRS providers that have a Meet Point Billing arrangement with BellSouth, and other network providers with which KMC desires to exchange traffic. This trunk group also carries KMC originated Transit Traffic transiting a single BellSouth access tandem destined to third party tandems such as an Independent Company tandem or other CLEC tandem. Upon reasonable notice, either Party's originated traffic may, in order to prevent or remedy traffic blocking situations, be transported on a separate single one-way trunk group terminating to the other Party. However, where KMC is responsive in a timely manner to BellSouth's transport needs for its originated traffic, BellSouth originating traffic will be placed on the two-way Local Traffic trunk group carrying ISP-bound Traffic and . Other trunk groups for operator services, directory assistance, emergency services and intercept may be established pursuant to the applicable BellSouth tariff if service is requested. The LERG contains current routing and tandem serving arrangements. The two-way trunk group architecture is illustrated in Exhibit D.

#### 4.8.1.4 **Supergroup Architecture**

In the supergroup architecture, the Parties' Local Traffic, ISP-bound Traffic and and KMC 's Transit Traffic are exchanged on a single two-way trunk group between KMC and BellSouth to provide Intratandem Access to KMC . This trunk group carries Transit Traffic between KMC and Independent Companies, Interexchange Carriers, other CLECs, CMRS providers that have a Meet Point Billing arrangement with BellSouth, and other network providers with which KMC desires to exchange traffic. This trunk group also carries KMC originated Transit Traffic transiting a single BellSouth access tandem destined to third party tandems such as an Independent Company tandem or other CLEC tandem. Upon reasonable notice, either Party's originated traffic may, in order to prevent or remedy traffic blocking situations, be transported on a separate single one-way trunk group terminating to the other Party . However, where KMC is responsive in a timely manner to BellSouth's transport needs for its originated traffic, BellSouth originating traffic will be placed on the Supergroup. Other trunk groups for operator services, directory assistance, emergency services and intercept may be established pursuant to the applicable BellSouth tariff if service is requested. The LERG contains current routing and tandem serving arrangements. The supergroup architecture is illustrated in Exhibit E.

#### 4.8.1.5 **Multiple Tandem Access Interconnection**

##### 4.8.1.5.1 Where KMC does not choose access tandem interconnection at every BellSouth access tandem within a LATA, KMC may utilize BellSouth's multiple tandem

access interconnection (MTA). To utilize MTA KMC must establish an interconnection trunk group(s) at a BellSouth access tandem through multiple BellSouth access tandems within the LATA as required. BellSouth will route KMC 's originated Local Traffic, ISP-bound Traffic and for LATA wide transport and termination. KMC must also establish an interconnection trunk group(s) at all BellSouth access tandems where KMC NXXs are homed as described in Section 4.2.1 above. If KMC does not have NXXs homed at any particular BellSouth access tandem within a LATA and elects not to establish an interconnection trunk group(s) at such BellSouth access tandem, KMC can order MTA in each BellSouth access tandem within the LATA where it does have an interconnection trunk group(s) and BellSouth will terminate KMC 's Local Traffic, ISP-bound Traffic and to End-Users served through those BellSouth access tandems where KMC does not have an interconnection trunk group(s). MTA shall be provisioned in accordance with BellSouth's Ordering Guidelines.

- 4.8.1.5.2 KMC may also utilize MTA to route its originated Transit Traffic; provided, however, that MTA may not be utilized to route switched access traffic that transits the BellSouth network to an Interexchange Carrier (IXC). Switched access traffic originated by or terminated to KMC will be delivered to and from IXCs based on KMC 's NXX access tandem homing arrangement as specified by KMC in the LERG.
- 4.8.1.5.3 Compensation for MTA shall be at the applicable tandem switching and transport charges specified in Exhibit A to this Attachment and shall be billed in addition to any Call Transport and Termination charges.
- 4.8.1.5.4 To the extent KMC does not purchase MTA in a LATA served by multiple access tandems, KMC must establish an interconnection trunk group(s) to every access tandem in the LATA to serve the entire LATA. To the extent KMC routes its traffic in such a way that utilizes BellSouth's MTA service without properly ordering MTA, KMC shall pay BellSouth the associated MTA charges.

#### 4.8.2 **Local Tandem Interconnection**

- 4.8.2.1 Local Tandem Interconnection arrangement allows KMC to establish its IP, pursuant to the provisions of this Attachment, and the associated interconnection trunk group(s) at BellSouth local tandems for: (1) the delivery of KMC – originated Local Traffic, ISP-bound Traffic and transported and terminated by BellSouth to BellSouth end offices served by those BellSouth local tandems, and (2) for local Transit Traffic transported by BellSouth for third party network providers who have also established an interconnection trunk group(s) at those BellSouth local tandems.
- 4.8.2.2 When a specified local calling area is served by more than one BellSouth local tandem, KMC must designate a “home” local tandem for each of its assigned NPA/NXXs and establish trunk connections to such local tandems. Additionally,

KMC may choose to establish an interconnection trunk group(s) at the BellSouth local tandems where it has no codes homing but is not required to do so. KMC may deliver Local Traffic, ISP-bound Traffic and to a “home” BellSouth local tandem that is destined for other BellSouth or third party network provider end offices subtending other BellSouth local tandems in the same local calling area where KMC does not choose to establish an interconnection trunk group(s). It is KMC’s responsibility to enter its own NPA/NXX local tandem homing arrangements into the LERG either directly or via a vendor in order for other third party network providers to determine appropriate traffic routing to KMC’s codes. Likewise, KMC shall obtain its routing information from the LERG.

4.8.2.3 Notwithstanding establishing an interconnection trunk group(s) to BellSouth’s local tandems, KMC must also establish an interconnection trunk group(s) to a BellSouth access tandem within the LATA on which KMC has NPA/NXXs homed for the delivery of Interexchange Carrier Switched Access (SWA) and toll traffic, and traffic to Type 2A CMRS connections located at the access tandems. BellSouth shall not switch SWA traffic through more than one BellSouth access tandem. SWA, Type 2A CMRS or toll traffic routed to the local tandem in error will not be backhauled to the BellSouth access tandem for completion. (Type 2A CMRS interconnection is defined in BellSouth’s A35 General Subscriber Services Tariff).

4.8.2.4 BellSouth’s provisioning of Local Tandem Interconnection assumes that KMC has executed the necessary local interconnection agreements with the other third party network providers subtending those local tandems as required by the Act.

#### 4.8.3 **Direct End Office-to-End Office Interconnection**

4.8.3.1 Direct End Office-to-End Office one-way or two-way interconnection trunk groups allow for the delivery of a Party’s originating Local Traffic, ISP-bound Traffic and to the terminating Party on a direct end office-to-end office basis.

4.8.3.2 The Parties may utilize direct end office-to-end office trunk groups under any one of the following conditions:

4.8.3.2.1 Tandem Exhaust – If a tandem through which the Parties are interconnected is unable to, or is forecasted to be unable to support additional traffic loads for the Parties or any other carrier for any period of time, the Parties will endeavor to mutually agree on an end office trunking plan or an appropriate alternate routing plan that will alleviate the tandem capacity shortage and ensure completion of traffic between KMC and BellSouth.

4.8.3.2.2 Traffic Volume –To the extent either Party has the capability to measure the amount of traffic between KMC’s switch and a BellSouth end office switch, and where such traffic exceeds or is forecasted to exceed a single DS3 (i.e. 8.9 million minutes) of traffic for three consecutive months, then the Parties shall install and

maintain direct end office trunking sufficient to handle such traffic volumes. Either Party will install and maintain additional capacity between such points when overflow traffic exceeds or is forecasted to exceed a single DS3 (i.e. 8.9 million minutes) of traffic for three consecutive months. In the case of one-way trunking, additional trunking shall only be required by the Party whose trunking has achieved the preceding usage threshold.

4.8.3.2.3 Mutual Agreement – The Parties may install direct end office trunking upon mutual agreement in the absence of conditions (1) or (2) above.

4.10.3.3 Overflow Routing - To the extent technically feasible and where appropriate, BellSouth will provide overflow routing consistent with how BellSouth overflows its traffic. The overflow will be based on the homing arrangements displayed in the LERG.

#### 4.8.4 Transit Traffic Trunk Group

Transit Traffic trunks can either be two-way trunks or two one-way trunks ordered by KMC to deliver and receive Transit Traffic. Establishing Transit Traffic trunks at BellSouth access and local tandems provides intratandem access to the third parties also interconnected at those tandems.

##### 4.8.4.1 Toll Free Traffic

4.8.4.1.1 If KMC chooses BellSouth to perform the Service Switching Point (SSP) Function (i.e., handle Toll Free database queries) from BellSouth's switches, all KMC originating Toll Free traffic will be routed over the Transit Traffic Trunk Group and shall be delivered using GR-394 format. Carrier Code "0110" and Circuit Code (to be determined for each LATA) shall be used for all such calls.

4.8.4.1.2 KMC may choose to perform its own Toll Free database queries from its switch. In such cases, KMC will determine the nature (local/intraLATA/interLATA) of the Toll Free call (local/IntraLATA/InterLATA) based on the response from the database. If the call is a BellSouth local or intraLATA Toll Free call, KMC will route the post-query local or IntraLATA converted ten-digit local number to BellSouth over the local or intraLATA trunk group. If the call is a third party (ICO, IXC, CMRS or other CLEC) local or intraLATA Toll Free call, KMC will route the post-query local or intraLATA converted ten-digit local number to BellSouth over the Transit Traffic Trunk Group and KMC shall provide to BellSouth a Toll Free billing record when appropriate. If the query reveals the call is an interLATA Toll Free call, KMC will route the post-query interLATA Toll Free call (1) directly from its switch for carriers interconnected with its network or (2) over the Transit Traffic Trunk Group to carriers that are not directly connected to KMC's network but that are connected to BellSouth's access tandem.

4.8.4.2 All post-query Toll Free calls for which KMC performs the SSP function, if delivered to BellSouth, shall be delivered using GR-394 format for calls destined to IXC's, and GR-317 format for calls destined to end offices that directly subtend a BellSouth access tandem within the LATA.

#### 4.8.5 **High Volume Calling (Mass Calling) Trunk Groups**

4.8.5.1 The Parties will cooperate to establish separate trunk groups, or provide some other means of protective controls (i.e., call gapping), for the completion of calls to high volume customers, such as radio contest lines.

4.8.5.2 Both parties agree to terminate each Party's mass calling codes as Local Traffic, where appropriate. The Parties agree that each will put in place controls for NXXs that are dedicated for media stimulated mass calling.

### 5. **NETWORK DESIGN AND MANAGEMENT FOR INTERCONNECTION**

5.1 Network Management and Changes. The Parties will work cooperatively with each other to install and maintain the most effective and reliable interconnected telecommunications networks, including but not limited to the exchange of toll-free maintenance contact numbers and escalation procedures. The Parties will provide public notice of network changes in the information necessary for the transmission and routing of services using their local exchange facilities and networks, to the extent required by, and in accordance with applicable federal and state rules and regulations.

5.2 Interconnection Technical Standards. The interconnection of all networks will be based upon accepted industry/national guidelines for transmission standards and traffic blocking criteria. Interconnecting facilities shall conform, at a minimum, to the telecommunications industry standard of DS-1 pursuant to Telcordia Standard No. TR-NWT-00499. Where KMC chooses to utilize Signaling System 7 signaling, also known as Common Channel Signaling (SS7), SS7 connectivity is required between the KMC switch and the BellSouth Signaling Transfer Point (STP). BellSouth will provide SS7 signaling using Common Channel Signaling Access Capability in accordance with the technical specifications set forth in the BellSouth Guidelines to Technical Publication, TR-TSV-000905. Facilities of each Party shall provide the necessary on-hook, off-hook answer and disconnect supervision and shall provide calling number ID (Calling Party Number) when technically feasible.

5.3 Quality of Interconnection. The local interconnection for the transmission and routing of telephone exchange service and exchange access that each Party provides to each other will be at least Equal in Quality to what it provides to itself and any subsidiary or affiliate, where technically feasible, or to any other Party to which each Party provides local interconnection.

- 5.3.1 In the event of an outage or trouble in any arrangement, facility, or service being provided by BellSouth hereunder, BellSouth will follow procedures for isolating and clearing the outage or trouble that are no less favorable than those that apply to comparable arrangements, facilities, or services being provided by BellSouth to itself, Affiliate or any other carrier whose network is connected to that of BellSouth.
- 5.3.2 “Equal in Quality” shall have the meaning accorded in Section 51.305(a)(3) of the FCC’s Rules, 47 C.F.R. § 51.305(a)(3). As soon as possible and in no case later than twenty-four (24) hours after receipt of notification of blocking of traffic originated within the other Party’s network, the Parties shall determine and begin work to implement reasonable corrective measures in a manner consistent with industry practices.
- 5.4 Network Management Controls. Both Parties will work cooperatively to apply sound network management principles by invoking appropriate network management controls (e.g., call gapping) to alleviate or prevent network congestion.



## 6. SIGNALING

- 6.1 BellSouth shall offer access to signaling and access to BellSouth’s signaling databases subject to compatibility testing and at the rates set forth in this Attachment. BellSouth may provide mediated access to BellSouth signaling systems and databases. Available signaling elements include signaling links, signal transfer points and service control points. Signaling functionality will be available with both A-link and B-link connectivity.
- 6.1.1 Both Parties will utilize LEC-to-LEC SS7 Signaling, where available, in conjunction with all traffic in order to enable full interoperability of CLASS features and functions except for call return. All SS7 signaling parameters will be provided, including but not limited to automatic number identification (ANI), originating line information (OLI) calling company category and charge number.
- 6.2 Signaling Link Transport
- 6.2.1 Signaling Link Transport is a set of two (2) or four (4) dedicated 56 kbps transmission paths between <<customer\_short\_name>> designated Signaling Points of Interconnection that provide appropriate physical diversity.
- 6.2.2 Technical Requirements

- 6.2.3 Signaling Link Transport shall consist of full duplex mode 56 kbps transmission paths and shall perform in the following two ways:
  - 6.2.3.1 An “A-link” Signaling Link Transport is a connection between a switch or SCP and a Signaling Transfer Point switch pair; and
  - 6.2.3.2 As a “B-link” Signaling Link Transport is a connection between two Signaling Transfer Point switch pairs in different company networks (e.g., between two Signaling Transfer Point switch pairs for two CLECs).
- 6.2.4 Signaling Link Transport shall consist of signaling link layers as follows:
  - 6.2.4.1 An A-link layer shall consist of two (2) links. There shall be no more than two (2) minutes down time per year for an A-link layer.
  - 6.2.4.2 A B-link layer shall consist of four (4) links. There shall be negligible (less than two (2) seconds) down time per year for a B-link layer.
- 6.2.5 A signaling link layer shall satisfy interoffice and intraoffice diversity of facilities and equipment, such that:
  - 6.2.5.1 No single failure of facilities or equipment causes the failure of both links in an A-link layer (i.e., the links should be provided on a minimum of two (2) separate physical paths end-to-end); and
  - 6.2.5.2 No two (2) concurrent failures of facilities or equipment shall cause the failure of all four (4) links in a B-link layer (i.e., the links should be provided on a minimum of three (3) separate physical paths end-to-end).
- 6.2.6 Interface Requirements
  - 6.2.6.1 There shall be a DS1 (1.544 Mbps) interface at <<customer\_short\_name>>’s designated SPOIs. Each 56 kbps transmission path shall appear as a DS0 channel within the DS1 interface.
- 6.3 Signaling Transfer Points (STPs)
  - 6.3.1 A Signaling Transfer Point is a signaling network function that includes all of the capabilities provided by the signaling transfer point switches (STPs) and their associated signaling links that enables the exchange of SS7 messages among and between switching elements, database elements and STPs.
  - 6.3.2 Technical Requirements

- 6.3.2.1 STPs shall provide access to BellSouth Local Switching or Tandem Switching and to BellSouth Service Control Points/Databases connected to BellSouth SS7 network. STPs also provide access to third-party local or tandem switching and third-party-provided STPs.
- 6.3.2.2 The connectivity provided by STPs shall fully support the functions of all other Network Elements connected to the BellSouth SS7 network. This includes the use of the BellSouth SS7 network to convey messages that neither originate nor terminate at a signaling end point directly connected to the BellSouth SS7 network (i.e., transit messages). When the BellSouth SS7 network is used to convey transit messages, there shall be no alteration of the Integrated Services Digital Network User Part or Transaction Capabilities Application Part (TCAP) user data that constitutes the content of the message.
- 6.3.2.3 STPs shall provide all functions of the SCCP necessary for Class 0 (basic connectionless) service, as defined in Telcordia ANSI Interconnection Requirements. This includes Global Title Translation (GTT) and SCCP Management procedures, as specified in ANSI T1.112.4. Where the destination signaling point is a <<customer\_short\_name>> or third party local or tandem switching system directly connected to BellSouth SS7 network, BellSouth shall perform final GTT of messages to the destination and SCCP Subsystem Management of the destination. In all other cases, BellSouth shall perform intermediate GTT of messages to a gateway pair of STPs in an SS7 network connected with the BellSouth SS7 network, and shall not perform SCCP Subsystem Management of the destination. If BellSouth performs final GTT to a <<customer\_short\_name>> database, then <<customer\_short\_name>> agrees to provide BellSouth with the Destination Point Code for <<customer\_short\_name>> database.
- 6.3.2.4 STPs shall provide all functions of the Operations, Maintenance and Administration Part (OMAP) as specified in applicable industry standard technical references, which may include, where available in BellSouth's network, MTP Routing Verification Test (MRVT); and SCCP Routing Verification Test (SRVT).
- 6.3.2.5 Where the destination signaling point is a BellSouth local or tandem switching system or database, or is a <<customer\_short\_name>> or third party local or tandem switching system directly connected to the BellSouth SS7 network, STPs shall perform MRVT and SRVT to the destination signaling point. In all other cases, STPs shall perform MRVT and SRVT to a gateway pair of STPs in an SS7 network connected with the BellSouth SS7 network. This requirement may be superseded by the specifications for Internetwork MRVT and SRVT when these become approved ANSI standards and available capabilities of BellSouth STPs.
- 6.4 SS7 Advanced Intelligent Network (AIN) Access



## 6.4.1 Interface Requirements

- 6.4.1.1 BellSouth shall provide the following STP options to connect <<customer\_short\_name>> or <<customer\_short\_name>>-designated local switching systems to the BellSouth SS7 network:
  - 6.4.1.1.1 An A-link interface from <<customer\_short\_name>> local switching systems; and,
  - 6.4.1.1.2 A B-link interface from <<customer\_short\_name>> local STPs.
- 6.4.1.2 Each type of interface shall be provided by one or more layers of signaling links.
- 6.4.1.3 The Signaling Point of Interconnection for each link shall be located at a cross connect element in the central office where the BellSouth STP is located.
- 6.4.1.4 BellSouth shall provide intraoffice diversity between the SPOI and BellSouth STPs, so that no single failure of intraoffice facilities or equipment shall cause the failure of both B-links in a layer connecting to a BellSouth STP.
- 6.4.1.5 STPs shall provide all functions of the MTP as defined in the applicable industry standard technical references.

## 6.4.2 Message Screening

- 6.4.2.1 BellSouth shall set message screening parameters so as to accept/send valid messages from <<customer\_short\_name>> local or tandem switching systems destined to/from any signaling point within BellSouth's SS7 network where the <<customer\_short\_name>> switching system has a valid signaling relationship.
- 6.4.3 BellSouth shall set message screening parameters so as to accept/send valid messages from <<customer\_short\_name>> local or tandem switching systems destined to/from any signalling point or network accessed through BellSouth's SS7 network where the <<customer\_short\_name>> switching system has a valid signalling relationship.

## 6.5 Service Control Points/Databases

- 6.5.1 Call Related Databases provide the storage of, access to, and manipulation of information required to offer a particular service and/or capability. BellSouth shall provide access to the following Databases: Local Number Portability, LIDB, Toll Free Number Database, Automatic Location Identification/Data Management System, and Calling Name Database. BellSouth also provides access to Service Creation Environment and Service Management System (SCE/SMS) application databases and Directory Assistance.

- 6.5.2 A Service Control Point (SCP) is deployed in a SS7 network that executes service application logic in response to SS7 queries sent to it by a switching system also connected to the SS7 network. Service Management Systems provide operational interfaces to allow for provisioning, administration and maintenance of subscriber data and service application data stored in SCPs.
- 6.5.3 Technical Requirements for SCPs/Databases
- 6.5.3.1 BellSouth shall provide physical access to SCPs through the SS7 network and protocols with TCAP as the application layer protocol.
- 6.5.3.2 BellSouth shall provide physical interconnection to databases via industry standard interfaces and protocols (e.g. SS7, ISDN and X.25).
- 6.5.3.3 The reliability of interconnection options shall be consistent with requirements for diversity and survivability.
- 6.6 Local Number Portability Database
- 6.6.1 The Permanent Number Portability (PNP) database supplies routing numbers for calls involving numbers that have been ported from one local service provider to another. BellSouth agrees to provide access to the PNP database at rates, terms and conditions as set forth by BellSouth and in accordance with an effective FCC or Commission directive.
- 6.7 SS7 Network Interconnection
- 6.7.1 SS7 Network Interconnection is the interconnection of <<customer\_short\_name>> local STPs or <<customer\_short\_name>> local or tandem switching systems with BellSouth STPs. This interconnection provides connectivity that enables the exchange of SS7 messages among BellSouth switching systems and databases, <<customer\_short\_name>> local or tandem switching systems, and other third-party switching systems directly connected to the BellSouth SS7 network.
- 6.7.2 The connectivity provided by SS7 Network Interconnection shall fully support the functions of BellSouth switching systems and databases and <<customer\_short\_name>> or other third-party switching systems with A-link access to the BellSouth SS7 network.
- 6.7.3 If traffic is routed based on dialed or translated digits between a <<customer\_short\_name>> local switching system and a BellSouth or other third-party local switching system, either directly or via a BellSouth tandem switching system, then it is a requirement that the BellSouth SS7 network convey via SS7

Network Interconnection the TCAP messages that are necessary to provide Call Management services (Automatic Callback, Automatic Recall, and Screening List Editing) between the <<customer\_short\_name>> local STPs and BellSouth or other third-party local switch.

- 6.7.4 SS7 Network Interconnection shall provide:
  - 6.7.4.1 Signaling Data Link functions, as specified in ANSI T1.111.2;
  - 6.7.4.2 Signaling Link functions, as specified in ANSI T1.111.3; and
  - 6.7.4.3 Signaling Network Management functions, as specified in ANSI T1.111.4.
- 6.7.5 SS7 Network Interconnection shall provide all functions of the SCCP necessary for Class 0 (basic connectionless) service, as specified in ANSI T1.112. This includes GTT and SCCP Management procedures, as specified in ANSI T1.112.4. Where the destination signaling point is a BellSouth switching system or database, or is another third-party local or tandem switching system directly connected to the BellSouth SS7 network, SS7 Network Interconnection shall include final GTT of messages to the destination and SCCP Subsystem Management of the destination. Where the destination signaling point is a <<customer\_short\_name>> local or tandem switching system, SS7 Network Interconnection shall include intermediate GTT of messages to a gateway pair of <<customer\_short\_name>> local STPs, and shall not include SCCP Subsystem Management of the destination.
- 6.7.6 SS7 Network Interconnection shall provide all functions of the Integrated Services Digital Network User Part, as specified in ANSI T1.113.
- 6.7.7 SS7 Network Interconnection shall provide all functions of the TCAP, as specified in ANSI T1.114.
- 6.7.8 If Internetwork MRVT and SRVT become approved ANSI standards and available capabilities of BellSouth STPs, SS7 Network Interconnection may provide these functions of the OMAP.
- 6.7.9 Interface Requirements
  - 6.7.9.1 The following SS7 Network Interconnection interface options are available to connect <<customer\_short\_name>> or <<customer\_short\_name>>-designated local or tandem switching systems or STPs to the BellSouth SS7 network:
    - 6.7.9.1.1 A-link interface from <<customer\_short\_name>> local or tandem switching systems; and

- 6.7.9.1.2 B-link interface from <<customer\_short\_name>> STPs.
- 6.7.9.2 The SPOI for each link shall be located at a cross-connect element in the central office where the BellSouth STP is located. There shall be a DS1 or higher rate transport interface at each of the SPOIs. Each signaling link shall appear as a DS0 channel within the DS1 or higher rate interface.
- 6.7.9.3 BellSouth shall provide intraoffice diversity between the SPOIs and the BellSouth STP, so that no single failure of intraoffice facilities or equipment shall cause the failure of both B-links in a layer connecting to a BellSouth STP.
- 6.7.9.4 The protocol interface requirements for SS7 Network Interconnection include the MTP, ISDNUP, SCCP, and TCAP. These protocol interfaces shall conform to the applicable industry standard technical references. BellSouth does not have the capability to support any of the VoIP interfaces at the present time but is willing to negotiate new protocol interfaces IAW 7.7.8.
- 6.7.9.5 BellSouth shall set message screening parameters to accept messages from <<customer\_short\_name>> local or tandem switching systems destined to any signaling point in the BellSouth SS7 network with which the <<customer\_short\_name>> switching system has a valid signaling relationship.
- 6.8 Rate Categories And Applications
  - 6.8.1 Message Charges
    - 6.8.1.1 Message charges, as set forth in 6.8.1.3, following, are assessed based on the type of message protocol, ISUP or TCAP. ISUP messages are associated with call set-up, while TCAP messages are used to query call related databases. ISUP message charges are assessed per terminating and originating call set-up request and TCAP message charges are assessed per data request.
    - 6.8.1.2 Message charges do not apply for TCAP messages switched by the regional STPs to the BellSouth provided 800 Data Base, LIDB or LNP Data Base. Query charges are assessed in lieu of message charges. Query charges for 800 Data Base are described in 6.9.5, following. When TCAP messages are destined for a foreign database, including a non-company provided LNP Data Base, message charges are assessed in lieu of query charges.
    - 6.8.1.3 Message charges are assessed in the following manner:
      - 6.8.1.3.1 Signal Formulation

- 6.8.1.3.1.1 An ISUP Signal Formulation charge is assessed, per call set-up request, for terminating and originating formulating signaling messages in association with call set-up.
- 6.8.1.3.2 Signal Transport
- 6.8.1.3.2.1 An ISUP Signal Transport charge is assessed, per call set-up request, for signaling messages transported to and from the Company STP in association with call set-up.
- 6.8.1.3.2.2 A TCAP Signal Transport charge is assessed per data request transported to a BellSouth STP and destined for a foreign database.
- 6.8.1.3.3 Signal Switching
- 6.8.1.3.3.1 An ISUP Signal Switching charge is assessed per call set-up request that is switched at the Company STP for terminating and originating messages .
- 6.8.1.3.3.2 A TCAP Signal Switching charge is assessed for each data request that is switched by the Company STP and destined for a foreign network or database.
- 6.8.1.3.4 Query Charges
- 6.8.1.3.4.1 Query charges apply for queries to the Company LIDB and the LNP Data Base. When query charges apply for access to a Company provided database, message charges are not assessed. LIDB Query Charges are described in 6.9.3, following and the LNP Data Base Query Charge is described in 6.9.4, following.
- 6.8.1.4 TCAP Bill and Keep
- 6.8.1.4.1 The Parties agree to treat signaling messages, signaling ports, and signaling links associated with local calls on a bill and keep basis.
- 6.8.1.4.2 <<customer\_short\_name>> and BellSouth agree that BellSouth will bill <<customer\_short\_name>> for signaling links, signaling ports, and signaling messages associated with interstate calls and with intrastate non-local calls in accordance with BellSouth's federal and state tariffs.
- 6.8.1.4.3 Beginning on the Effective Date of this Agreement and continuing until <<customer\_short\_name>> implements a system that is capable of counting the total number of signaling messages that traveled over facilities connecting <<customer\_short\_name>>'s CCS7 network and BellSouth's CCS7 network, BellSouth agrees that for the purposes of billing BellSouth for signaling messages for any given month, <<customer\_short\_name>> may use the total number of signaling messages that BellSouth's signaling bill to <<customer\_short\_name>>

indicates have traveled over facilities connecting <<customer\_short\_name>>'s CCS7 network and BellSouth's CCS7 network for that same month. When <<customer\_short\_name>> implements a system that is capable of counting the total number of signaling messages that travel over facilities connecting <<customer\_short\_name>>'s CCS7 network and BellSouth's CCS7 network, <<customer\_short\_name>> will use the number of signaling messages counted by such system for the purposes of billing BellSouth for signaling messages, subject to BellSouth's right to contest the accuracy of the number of signaling messages counted by such system.

- 6.8.1.4.4 For the purposes of billing BellSouth for signaling messages, <<customer\_short\_name>> will apply the SPIU/SPLU provided by BellSouth (which can, at BellSouth's option, be the same as the PIU/PLU that BellSouth provides for minutes of use) to the number of messages calculated pursuant to Paragraph 6.8.1.4.3 above.

## 6.9 RATES AND CHARGES ASSOCIATED WITH SS7

- |       |                                  |             |
|-------|----------------------------------|-------------|
| 6.9.1 | Message Charge for ISUP Messages | RATE        |
|       | Per signaling message            | Bill & Keep |

- |       |                                  |             |
|-------|----------------------------------|-------------|
| 6.9.2 | Message Charge for TCAP Messages | RATE        |
|       | Per signaling message            | Bill & Keep |

## 6.9.3 LINE INFORMATION DATA BASE SERVICE

### RATE PER QUERY

- |                              |  |
|------------------------------|--|
| Per Access Transport Query   | Exhibit A of Attachment 2 for UNE-P Only, Tariff Rate for All Others |
| Per Validation Service Query | Exhibit A of Attachment 2 for UNE-P Only, Tariff Rate for All Others |
| Per OLNS Service Query       | Tariff Rate  |

## 6.9.4 LOCAL NUMBER PORTABILITY DATA BASE SERVICE

- |               |  |
|---------------|--|
| Per LNP Query | Exhibit A of Attachment 2 for UNE-P Only |
|---------------|--|

Negotiated Rates Pursuant to a Separate Agreement for All Others

6.9.5 800 DATA BASE SERVICE

Per 800 Query

Exhibit A of Attachment 2 for UNE-P Only,  
Tariff Rate for All Others

**7. FORECASTING FOR TRUNK PROVISIONING**

- 7.1 Within six (6) months after execution of this Agreement, KMC shall provide an initial interconnection trunk group forecast for each LATA in which it plans to provide service within BellSouth's region. BellSouth shall then provide to KMC reciprocal trunking forecasts. BellSouth's reciprocal trunking forecasts will be based upon information provided by <<customer\_short\_name>> in the initial forecast. If <<customer\_short\_name>> refuses to provide such information, BellSouth shall provide reciprocal trunking forecasts based only on existing trunk group growth and BellSouth's annual estimated percentage of BellSouth subscriber line growth. After the exchange of each Party's forecast, the Parties shall conduct a joint planning meeting to develop a joint interconnection trunk group forecast. Each forecast provided under this Section shall be deemed "Confidential Information" under the General Terms and Conditions of this Agreement.
- 7.2 The Parties shall use best efforts to make the initial and annual subsequent forecasts as accurate as possible based on reasonable engineering criteria. In addition, the Parties agree to proactively manage their interconnection trunking arrangements and use best efforts to timely notify each other if forecasted need quantities change or if a known or anticipated network event that may create a blocking situation is likely to occur during the time period between joint planning meetings. Joint planning meetings shall be conducted via conference call, unless mutual agreement is reached otherwise.
- 7.3 At a minimum, the joint forecast shall include the projected quantity of Transit Trunks, KMC -to-BellSouth one-way trunks (KMC Trunks), BellSouth-to-KMC one-way trunks (Reciprocal Trunk Groups) and/or two-way interconnection trunks, if the Parties have agreed to interconnect using two-way trunking to transport the Parties' Local Traffic, ISP-Bound Traffic, and . The quantities shall be projected for a minimum of six months and shall include an estimate of the current year plus the next two years total forecasted quantities. The Parties shall mutually develop Reciprocal Trunk Groups and/or two-way interconnection trunk forecast quantities
- 7.4 All forecasts shall include, at a minimum, Access Carrier Terminal Location (ACTL), trunk group type (local/intraLATA toll, Transit, Operator Services, 911,

etc.), A location/Z location (CLLI codes for KMC location and BellSouth location where the trunks shall terminate), interface type (e.g., DS1), Direction of Signaling, Trunk Group Number, if known, (commonly referred to as the 2-6 code) and forecasted trunks in service each year (cumulative).

- 7.5 Once initial interconnection trunk forecasts have been developed, KMC shall continue to provide interconnection trunk forecasts on an annual basis or at otherwise mutually agreeable intervals. KMC shall use its best efforts to make the forecasts as accurate as possible based on reasonable engineering criteria. The Parties shall continue to exchange Reciprocal Trunk Group and/or two-way interconnection trunk forecasts as described in Section 7.1.
- 7.6 The submitting and development of interconnection trunk forecasts shall not replace the ordering process for local interconnection trunks. Each Party shall exercise its best efforts to provide the quantity of interconnection trunks mutually forecasted. However, the provision of the forecasted quantity of interconnection trunks is subject to trunk terminations and facility capacity existing at the time the trunk order is submitted and the provisioning Party shall not be responsible for a lack of interconnection trunks provided that the provisioning Party can establish that best efforts and good faith have been exercised. Furthermore, the receipt and development of trunk forecasts does not imply any liability for failure to perform if capacity (trunk terminations or facilities) is not available for use at the forecasted time.

## 8. **TRUNK UTILIZATION**

- 8.1 For the Reciprocal Trunk Groups that cannot overflow traffic to another trunk group (Reciprocal Final Trunk Groups), BellSouth and KMC shall monitor traffic on each interconnection Reciprocal Final Trunk Group that is ordered and installed. The Parties agree that the Reciprocal Final Trunk Groups will be utilized at 60 percent (60%) of the time consistent busy hour utilization level within 120 days of installation. The Parties agree that the Reciprocal Final Trunk Groups will be utilized at eighty percent (80%) of the time consistent busy hour utilization level within 180 days of installation. Any Reciprocal Final Trunk Group not meeting the minimum thresholds set forth in this Section are defined as "Under-utilized" trunks. BellSouth may disconnect any Under-utilized Reciprocal Final Trunk Groups and, for trunks not in excess of KMC's forecast, KMC shall refund to BellSouth the associated nonrecurring and recurring trunk and facility charges paid by BellSouth, if any.
- 8.1.1 Any Reciprocal Final Trunk Group not meeting the minimum thresholds set forth in this Section are defined as "Under-Utilized" trunks. BellSouth's CISC will notify KMC of any under-utilized Reciprocal Trunk Groups and the number of such trunk groups that BellSouth wishes to disconnect. BellSouth will provide supporting information either by email or facsimile to the designated KMC interface. KMC will provide concurrence with the disconnection in ten (10)



business days or will provide specific information supporting why the trunks should not be disconnected. Such supporting information should include expected traffic volumes (including traffic volumes generated due to Local Number Portability) and the timeframes within which KMC expects to need such trunks. BellSouth's CISC Project Manager and Circuit Capacity Manager will discuss the information with KMC to determine if agreement can be reached on the number of Reciprocal Final Trunk Groups to be removed. If no agreement can be reached, BellSouth will issue disconnect orders to KMC. The due date of these orders will be thirty (30) calendar days after KMC was first notified in writing of the underutilization of the trunk groups, unless otherwise agreed to by the Parties. When BellSouth issues disconnect orders to KMC for any Under-utilized Reciprocal Final Trunk Groups, KMC shall refund to BellSouth the associated nonrecurring and recurring trunk and facility charges paid by BellSouth to KMC, if any.

8.1.2 To the extent that any interconnection trunk group is utilized at a time-consistent busy hour of eighty percent (80%) or greater, the Parties may review the trunk groups and, if necessary, shall negotiate in good faith for the installation of augmented facilities.

8.2 For the two-way trunk groups that cannot overflow traffic to another trunk group and other than alternate final trunk groups, BellSouth and KMC shall monitor traffic on each interconnection trunk group that is ordered and installed. The Parties agree that within 120 days of the installation of the BellSouth two-way trunk or trunks, the trunks will be utilized at 60 percent (60%) of the time consistent busy hour utilization level. The Parties agree that within 180 days of the installation of a trunk or trunks, the trunks will be utilized at eighty percent (80%) of the time consistent busy hour utilization level. Any trunk or trunks not meeting the minimum thresholds set forth in this Section are defined as "Under-utilized" trunks. BellSouth will request the disconnection of any Under-utilized two-way trunk(s) and, for trunks not in excess of KMC's forecast, KMC shall refund to BellSouth the associated nonrecurring and recurring trunk and facility charges paid by BellSouth, if any.

8.2.1 BellSouth's LISC will notify KMC of any under-utilized two-way trunk groups and the number of trunks that BellSouth wishes to disconnect. BellSouth will provide supporting information either by email or facsimile to the designated KMC interface. KMC will provide concurrence with the disconnection in ten (10) business days or will provide specific information supporting why the two-way trunks should not be disconnected. Such supporting information should include expected traffic volumes (including traffic volumes generated due to Local Number Portability) and the timeframes within which KMC expects to need such trunks. BellSouth's CISC Project Manager and Circuit Capacity Manager will discuss the information with KMC to determine if agreement can be reached

on the number of trunks to be removed. If no agreement can be reached, KMC will issue disconnect orders to BellSouth. The due date of these orders will be thirty (30) calendar days after KMC was first notified in writing of the underutilization of the trunk groups, unless otherwise agreed to by the Parties.

- 8.2.2 To the extent that any interconnection trunk group is utilized at a time-consistent busy hour of eighty percent (80%) or greater, the Parties shall review the trunk groups and, if necessary, shall negotiate in good faith for the installation of augmented facilities.

## **9. INTERFERENCE OR IMPAIRMENT**

- 9.1 As soon as possible and in no case later than twenty-four (24) hours after receipt of notification of blocking of traffic originated within the other Party's network, the Parties shall determine and begin work to implement reasonable corrective measures in a manner consistent with industry practices.
- 9.2 In the event of an outage or trouble in any arrangement, facility, or service being provided by BellSouth hereunder, BellSouth will follow procedures for isolating and clearing the outage or trouble that are no less favorable than those that apply to comparable arrangements, facilities, or services being provided by BellSouth to itself, Affiliate or any other carrier whose network is connected to that of BellSouth.
- 9.3 BellSouth will use best efforts to provide <<customer\_short\_name>> with at least thirty (30) days advance notification of scheduled maintenance activity. Upon such notice, <<customer\_short\_name>> may submit a reasonable request for additional information relevant to the scheduled maintenance activity and BellSouth shall provide such information to the extent the scheduled maintenance activity may impact <<customer\_short\_name>> and such information is reasonably necessary for <<customer\_short\_name>> to identify and analyze potential risks associated with such maintenance. BellSouth may expedite or delay scheduled maintenance as a result of unscheduled maintenance or other unforeseen events. In those instances where BellSouth will not perform scheduled maintenance at the announced times, BellSouth will make best efforts to provide <<customer\_short\_name>> with as much notice as is reasonably possible concerning the changed schedule.
- 9.4 For switch software/processor updates, software upgrades/new releases to the SONET transport network elements, or other major scheduled events which might impact <<customer\_short\_name>>, BellSouth shall use best efforts to provide <<customer\_short\_name>> with at least thirty (30) days advance notification of scheduled maintenance activity. Upon such notice, <<customer\_short\_name>> may submit a reasonable request for additional information relevant to the scheduled maintenance activity and BellSouth shall provide such information to

the extent the scheduled maintenance activity may impact <<customer\_short\_name>> and such information is reasonably necessary for <<customer\_short\_name>> to identify and analyze potential risks associated with such maintenance.

9.5 BellSouth will provide <<customer\_short\_name>>'s Network Operations Center with written notice when translations are scheduled to be modified on <<customer\_short\_name>>'s trunk groups. BellSouth shall use best efforts to provide such notice 30 days in advance of such scheduled activity, or as close thereto as possible.

9.6 [Parties Disagree]

[KMC Version] Once <<customer\_short\_name>> determines that there is an outage that encompasses either a particular section of the network or the whole network, then <<customer\_short\_name>> shall generate a trouble ticket to the CISC. After issuing the trouble ticket, <<customer\_short\_name>> will notify the appropriate BellSouth representative in the CISC via telephone. <<customer\_short\_name>> may then send an email confirmation to such BellSouth representative. BellSouth will work cooperatively with <<customer\_short\_name>> to determine the appropriate steps to resolve such outage. Additionally, <<customer\_short\_name>> will provide BellSouth with any applicable information that is necessary to resolve such outage and the Parties will work cooperatively to take all steps necessary to resolve the outage. **Upon request, BellSouth will provide a written root cause analysis report for all global outages, and for any trunk group outage that has occurred 3 or more times in a 60 day period. BellSouth shall use best efforts to provide such report within five (5) business days after the request for it is made.**

[BellSouth Version] Once <<customer\_short\_name>> determines that there is an outage that encompasses either a particular section of the network or the whole network, then <<customer\_short\_name>> shall generate a trouble ticket to the CISC. After issuing the trouble ticket, <<customer\_short\_name>> will notify the appropriate BellSouth representative in the CISC via telephone. <<customer\_short\_name>> may then send an email confirmation to such BellSouth representative. BellSouth will work cooperatively with <<customer\_short\_name>> to determine the appropriate steps to resolve such outage. Additionally, <<customer\_short\_name>> will provide BellSouth with any applicable information that is necessary to resolve such outage and the Parties will work cooperatively to take all steps necessary to resolve the outage. **<<customer\_short\_name>> may submit a reasonable request to BellSouth for a written analysis of the cause of any global outage affecting <<customer\_short\_name>>'s network. BellSouth shall use best efforts to provide such report within thirty (30) days of such request.**

**10. COMPENSATION FOR CALL TRANSPORTATION AND TERMINATION FOR LOCAL TRAFFIC AND ISP-BOUND TRAFFIC**

10.1 [Parties Disagree]

[KMC Version] Notwithstanding any other provision in this Attachment 3, the Parties shall pay each other reciprocal compensation for the transport and termination of Local Traffic at the elemental rates for end office switching, tandem switching and transport, as set forth in Exhibit A. The terminating Party is entitled to bill and the originating Party is obligated to pay reciprocal compensation to the terminating Party at a symmetrical tandem interconnection rate, inclusive of end office switching, tandem switching and transport.

[BellSouth Version] Each Party shall pay compensation to the other Party for the per minute of use rate elements associated with the Call Transport and Termination of Local Traffic.

10.2 [Parties Disagree]

[KMC Version] For the per minute of use rate elements associated with Call Transport and Termination, the Parties shall compensate each other at the rate of \$0.0007 per minute of use for ISP-bound Traffic

[BellSouth Version] For the per minute of use rate elements associated with Call Transport and Termination **of ISP-bound Traffic**, the Parties shall compensate each other at the rate of \$0.0007 **per minute of use subject to the ceiling of minutes as set forth below.**

10.2.1 [Parties Disagree]

[KMC Version] No section.

[BellSouth Version] For ISP-bound Traffic exchanged from the Effective Date through the Expiration Date of this Agreement, compensation as set forth in Section 10.2 shall be billed by the terminating Party to the originating Party on the ISP-bound minutes up to a ceiling of ISP-bound minutes, which shall be calculated as set forth in the ISP Order on Remand. The Parties shall exchange data to determine the appropriate volume of minutes to be utilized.

10.3 Notwithstanding the definitions of Local Traffic and ISP-bound Traffic in this Attachment, and pursuant to the FCC's Order on Remand and Report and Order in CC Docket 99- 68 released April 27, 2001 ("ISP Order on Remand"), BellSouth and <<customer\_short\_name>> agree to the rebuttable presumption that all combined Local and ISP-bound Traffic delivered to BellSouth or <<customer\_short\_name>> that exceeds a 3:1 ratio of terminating to originating traffic on a statewide basis shall be considered ISP-bound Traffic for compensation purposes. BellSouth and <<customer\_short\_name>> further

agree to the rebuttable presumption that all combined Local and ISP-bound Traffic delivered to BellSouth or <<customer\_short\_name>> that does not exceed a 3:1 ratio of terminating to originating traffic on a statewide basis shall be considered Local Traffic for compensation purposes.

- 10.4 The appropriate elemental rates set forth in Exhibit A of this Attachment shall apply for Transit Traffic as described in this Attachment and to Multiple Tandem Access as described in this Attachment.
- 10.5 Neither Party shall represent Switched Access Traffic as Local Traffic or ISP-bound Traffic for purposes of determining compensation for the call.
- 10.6 If <<customer\_short\_name>> assigns NPA/NXXs to specific BellSouth rate centers within the LATA and assigns numbers from those NPA/NXXs to <<customer\_short\_name>> End Users physically located outside of that LATA, BellSouth originated traffic that is not bound for an Internet Service Provider (“ISP”) and originates from within the LATA where the NPA/NXXs are assigned and is delivered to a <<customer\_short\_name>> End User physically located outside of such LATA shall not be deemed Local Traffic. Further, <<customer\_short\_name>> agrees to identify such traffic to BellSouth, to the extent technically feasible, and to compensate BellSouth for originating and transporting such non-local traffic to <<customer\_short\_name>> at BellSouth’s switched access tariff rates.
- 10.6.1 The Parties have been unable to agree on the treatment of calls where <<customer\_short\_name>> assigns NPA/NXXs to specific BellSouth rate centers within the LATA and assigns numbers from those NPA/NXXs to <<customer\_short\_name>> End Users physically located outside of that LATA and such End Users are Internet Service Providers (“ISPs”). Notwithstanding the foregoing, and without waiving any rights with respect to either Party’s position as to the treatment of such calls, the Parties agree that, for purposes of this Agreement, traffic delivered to an End User that is an ISP physically located outside of such LATA shall be considered ISP-bound Traffic as defined in this Attachment.
- 10.7 **Jurisdictional Reporting**
- 10.7.1 **Percent Local Use.** Each Party shall report to the other a Percent Local Usage (PLU) factor. The application of the PLU will determine the amount of local or ISP-bound minutes to be billed to the other Party. Local Traffic and ISP-bound Traffic shall be treated as Local for purposes of calculating the PLU.

Requirements associated with PLU calculation and reporting shall be as set forth in BellSouth's Jurisdictional Factors Reporting Guide, as it is amended from time to time.

- 10.7.2 **Percent Local Facility**. Each Party shall report to the other a Percent Local Facility (PLF) factor. The application of the PLF will determine the portion of switched dedicated transport to be billed per the local jurisdiction rates. The PLF shall be applied to Multiplexing, Local Channel and Interoffice Channel Switched Dedicated Transport utilized in the provision of local interconnection trunks. Local Traffic and ISP-bound Traffic shall be treated Local for the purposes of calculating the PLF. Requirements associated with PLF calculation and reporting shall be as set forth in BellSouth's Jurisdictional Factors Reporting Guide.
- 10.7.3 **Percent Interstate Usage**. Each Party shall report to the other the projected Percent Interstate Usage (PIU) factor. . After interstate and intrastate traffic percentages have been determined by use of PIU procedures, the PLU and PLF factors will be used for application and billing of local interconnection. Requirements associated with PIU calculation and reporting shall be as set forth in BellSouth Jurisdictional Factors Reporting Guide.
- 10.7.4 In Lieu of Jurisdictional Factors Reported. Notwithstanding the provisions in Section 10.5.1, 10.5.2, and 10.5.3 above, where the terminating Party has message recording technology that identifies the jurisdiction of traffic terminated as defined in this Agreement, such information may, at the terminating Party's option, be utilized to determine the appropriate jurisdictional reporting factors, in lieu of those provided by the originating Party. In the event that the terminating Party opts to utilize its own data to determine jurisdictional reporting factors, such terminating Party shall notify the originating Party at least 30 days prior to the beginning of the calendar quarter in which the terminating Party will begin to utilize its own data.
- 10.7.4.1 Upon the request of the originating Party, the terminating Party shall provide supporting data for the jurisdictional factors proposed by the terminating Party to be used in lieu of those reported by the originating Party. The originating Party shall have 30 days to consent or object to the proposed replacement of reported factors. If the originating Party consents or fails to respond within 30 days, the terminating Party may proceed with the replacement of factors effective at the beginning of the calendar quarter. If the originating Party objects to the proposed replacement of reported factors, the Parties shall proceed as set forth below.
- 10.7.4.2 **[Parties Disagree]**
- [KMC Version]** Upon either Party's request, the Parties will work in good faith to resolve the discrepancy between the factors submitted by the originating party and those proposed by the terminating party pursuant to Section 7.2.5 above. In the event that the Parties are unable to mutually agree as to the appropriate

resolution, the Parties may negotiate a mutually agreeable resolution based on the data specific to the traffic patterns of the originating party or either Party may request an audit of the factors in accordance with Section 7.2.9 below. In the event that negotiations and audits fail to resolve disputes between the parties, either Party may seek Dispute Resolution as set forth in the General Terms and Conditions. **While such a dispute is pending, factors reported by the originating Party shall remain in place, unless the Parties mutually agree otherwise.**

**[BellSouth Version]** Upon either Party's request, the Parties will work in good faith to resolve the discrepancy between the factors submitted by the originating party and those proposed by the terminating party pursuant to Section 7.2.5 above. In the event that the Parties are unable to mutually agree as to the appropriate resolution, the Parties may negotiate a mutually agreeable resolution based on the data specific to the traffic patterns of the originating party or either Party may request an audit of the factors in accordance with Section 7.2.9 below. In the event that negotiations and audits fail to resolve disputes between the parties, either Party may seek Dispute Resolution as set forth in the General Terms and Conditions. **While such a dispute is pending, the factors proposed by the terminating Party pursuant to Section 7.2.5 above shall be utilized, unless the Parties mutually agree otherwise.**

10.7.5 Audits. On thirty (30) days written notice, each Party must provide the other the ability and opportunity to conduct an annual audit to ensure the proper billing of traffic. BellSouth and KMC shall retain records of call detail for a minimum of nine months from which the PLU, PLF and/or PIU can be ascertained. The audit shall be conducted during normal business hours at an office designated by the Party being audited. Audit requests shall not be submitted more frequently than one (1) time per calendar year. Audits shall be performed by a mutually acceptable independent auditor paid for by the Party requesting the audit. The PLF, PLU and/or PIU shall be adjusted based upon the audit results and shall apply for the quarter the audit was completed, for the quarter prior to the completion of the audit, and for the two quarters following the completion of the audit. If, as a result of an audit, either Party is found to have overstated the PLF, PLU and/or PIU by twenty percentage points (20%) or more, that Party shall reimburse the auditing Party for the cost of the audit.

10.8 Compensation for 8XX Traffic

7.6.1 Compensation for 8XX Traffic. Each Party shall pay the other the appropriate switched access charges set forth in the BellSouth intrastate or interstate switched access tariffs. KMC will pay BellSouth the database query charge as set forth in the BellSouth intrastate or interstate switched access tariffs as applicable.

- 10.8.1 Records for 8XX Billing. Each Party will provide to the other the appropriate records necessary for billing intraLATA 8XX customers. The records provided will be in a standard EMI format.
- 10.8.2 8XX Access Screening. BellSouth's provision of 8XX Toll Free Dialing (TFD) to KMC requires interconnection from KMC to BellSouth's 8XX Signal Channel Point (SCP). Such interconnections shall be established pursuant to BellSouth's Common Channel Signaling Interconnection Guidelines and Telcordia's CCS Network Interface Specification document, TR-TSV-000905. KMC shall establish SS7 interconnection at the BellSouth Local Signal Transfer Points serving the BellSouth 8XX SCPs that KMC desires to query. The terms and conditions for 8XX TFD are set out in BellSouth's Intrastate Access Services Tariff.
- 10.9 Mutual Provision of Switched Access Service
- 10.9.1 Switched Access Traffic. Switched Access Traffic is described as telephone calls requiring local transmission or switching services for the purpose of the origination or termination of Telephone Toll Service. Switched Access Traffic includes, but is not limited to, the following types of traffic: Feature Group A, Feature Group B, Feature Group C, Feature Group D, toll free access (e.g., 8XX), and 900 access. Switched Access Traffic does not include Local Traffic and ISP-Bound Traffic originated by one Party and terminated by the other. ok)
- 10.9.2 Voice-Over-Internet-Protocol ("VOIP") Transmissions. The Parties have been unable to agree as to whether "Voice-Over-Internet-Protocol" transmissions ("VOIP") which cross LATA boundaries constitute Switched Access Service Traffic. Notwithstanding the foregoing, and without waiving any rights with respect to either Party's position as to the jurisdictional nature of VOIP, the Parties agree to amend this Agreement in accordance with the General Terms and Conditions of this Agreement to abide by any effective and applicable FCC rules and orders regarding the nature of such traffic and the compensation payable by the Parties for such traffic, if any.
- 10.9.3 If the BellSouth End User chooses KMC as their presubscribed interexchange carrier, or if the BellSouth End User uses KMC as an interexchange carrier on a 101XXXX basis, BellSouth will charge KMC the appropriate BellSouth tariff charges for originating switched access services.
- 10.9.4 When one Party's end office switch, subtending the other Party's Access Tandem switch for receipt or delivery of switched access traffic, provides an access service connection to or from an interexchange carrier ("IXC") by either a direct trunk group to the IXC utilizing the other Party's facilities, or via the other



Party's tandem switch, each Party will provide its own access services to the IXC and bill on a multi-bill, multi-tariff meet-point basis. Each Party will bill its own access services rates to the IXC with the exception of the interconnection charge. The interconnection charge will be billed by the Party providing the end office function. The Parties will use the Multiple Exchange Carrier Access Billing (MECAB) guidelines to establish meet point billing for all applicable traffic. . Thirty (30)-day billing periods will be employed for these arrangements. To the extent either party is providing the tandem function, that party (i.e., Initial Billing Company) agrees to provide to the other company (i.e., Subsequent Billing Company), as defined in MECAB, at no charge, the switched access detailed usage data within no more than sixty (60) days after the recording date where technically feasible. Each company will notify the other when it determines that it is not feasible to meet these requirements so that the customers may be notified for any necessary revenue accrual associated with the significantly delayed recording or billing. As business requirements change, data reporting requirements may be modified as necessary, by mutual agreement of the Parties or per a change in industry standards.

10.9.5

[Parties Disagree]

**[KMC Version]** In the event that either Party fails to provide accurate switched access detailed usage data to the other Party within 90 days after the recording date and the receiving Party is unable to bill and/or collect access revenues due to the sending Party's failure to provide such data within said time period, then the Party failing to send the data as specified herein shall be liable to the other Party in an amount equal to the unbillable or uncollectible revenues. Each company will provide complete documentation to the other to substantiate any claim of such unbillable or uncollectible access revenues. In the event that the Parties disagree as to the liability of the Initial Billing Party for such unbillable or uncollectible revenues, then either Party may invoke the Dispute Resolution process set forth in this Agreement.

**[BellSouth Version]** In the event that the Initial Billing Party, as defined in Section 7.4.4 herein, was provided the accurate switched access detailed usage data in a manner that allowed the Initial Billing Party to generate and provide such data to the Subsequent Billing Party in a reasonable timeframe and where the Initial Billing Party failed to provide notice to the Subsequent Billing Party of any inability to provide such data within a reasonable and nondiscriminatory timeframe and the Subsequent Billing Party is unable to bill and/or collect access revenues due to the Initial Billing Party's failure to provide such data within said time period, then the Initial Billing Party shall be liable to the other Party in an amount equal to the unbillable or uncollectible revenues. Each company will provide complete documentation to the other to substantiate any claim of such unbillable or uncollectible revenues. In the event that the Parties disagree as to the liability of the Initial Billing Party

for such unbillable or uncollectible revenues, then either Party may invoke the Dispute Resolution process set forth in this Agreement.

10.9.6 The Initial Billing Company will retain for a minimum period of sixty (60) days, access message detail sufficient to recreate any data that is lost or damaged by the tandem provider company or any third party involved in processing or transporting data. Initial Billing Company agrees to recreate the lost or damaged data within forty-eight (48) hours of notification by the other or by an authorized third party handling the data.

10.9.7 Initial Billing Company also agrees to process the recreated data within forty-eight (48) hours of receipt at its data processing center.

10.9.8 All claims for unbillable or uncollectible revenue should be filed with the Initial Billing Company within 120 days of the date the receipt of the usage record.

10.9.9 The Initial Billing Party shall keep records of its billing activities relating to jointly-provided Intrastate and Interstate Switched Access Traffic Services in sufficient detail to permit the Subsequent Billing Party to, by formal or informal review or audit, to verify the accuracy and reasonableness of the jointly-provided access billing data provided by the Initial Billing Party. Each Party agrees to cooperate in such formal or informal reviews or audits and further agrees to jointly review the findings of such reviews or audits in order to resolve any differences concerning the findings thereof. In the absence of mutual agreement otherwise, the Audit provisions set forth in Section 10.5.6.3 of this Attachment shall govern.

10.10 Transit Traffic

10.10.1 [Parties Disagree]

[KMC's Version] Each Party shall provide tandem switching and transport services for the other Party's Transit Traffic. Rates for Local Transit Traffic and ISP-Bound Transit Traffic shall be the applicable Call Transport and Termination charges (i.e., common transport and tandem switching charge; end office switching charge is not applicable) as set forth in Exhibit A to this Attachment. Rates for Switched Access Transit Traffic shall be the applicable charges as set forth in the applicable Party's Commission approved Interstate or Intrastate Switched Access tariffs as filed and effective with the FCC or Commission, or reasonable and non-discriminatory web-posted listing if the FCC or Commission does not require filing of a tariff. Billing associated with all Transit Traffic shall be pursuant to MECAB guidelines.

[BellSouth's Version] Each Party shall provide tandem switching and transport services for the other Party's Transit Traffic. Rates for Local Transit Traffic and ISP-Bound Transit Traffic shall be the applicable Call Transport and Termination charges (i.e., common transport and tandem switching charges and **tandem**

**intermediary charge**; end office switching charge is not applicable) as set forth in Exhibit A to this Attachment. Rates for Switched Access Transit Traffic shall be the applicable charges as set forth in the applicable Party's Commission approved Interstate or Intrastate Switched Access tariffs as filed and effective with the FCC or Commission, or reasonable and non-discriminatory web-posted listing if the FCC or Commission does not require filing of a tariff. Billing associated with all Transit Traffic shall be pursuant to MECAB guidelines.

- 10.10.2 Traffic between KMC and Wireless Type 1 third parties or a third party CLEC utilizing BellSouth switching (including resellers and UNE-P providers) shall not be treated as Transit Traffic from a routing or billing perspective. Traffic originated by a Wireless Type 1 third party or a third party CLEC utilizing BellSouth switching (including resellers and UNE-P providers) shall be treated as BellSouth-originated traffic and BellSouth shall compensate KMC for transport and termination of such traffic based on the classification of such traffic as Local Traffic, ISP-Bound Traffic, or Switched Access Traffic in accordance with the terms of this Attachment.
- 10.10.3 Traffic between KMC and Wireless Type 2A third parties shall not be treated as Transit Traffic from a routing or billing perspective until BellSouth and the Wireless Type 2A carrier have the capability to properly meet-point-bill in accordance with MECAB guidelines. Until such time, such traffic originated by Wireless Type 2A third parties shall be treated as BellSouth-originated traffic and BellSouth shall compensate KMC for transport and termination of such traffic based on the classification of such traffic as Local Traffic, ISP-Bound Traffic, or Switched Access Traffic in accordance with the terms of this Attachment.
- 10.10.4 Traffic between BellSouth and Wireless Type 1 third parties or a third party CLEC utilizing KMC switching shall not be treated as Transit Traffic from a routing or billing perspective. Such traffic originated by a Wireless Type 1 third party or a third party CLEC utilizing KMC switching shall be treated as KMC-originated traffic and KMC shall compensate BellSouth for transport and termination of such traffic based on the classification of such traffic as Local Traffic, ISP-Bound Traffic, or Switched Access Traffic in accordance with the terms of this Attachment.
- 10.10.5 Traffic between BellSouth and Wireless Type 2A third parties shall not be treated as Transit Traffic from a routing or billing perspective until KMC and the Wireless Type 2A carrier have the capability to properly meet-point-bill in accordance with MECAB guidelines. Until such time, such traffic originated by Wireless Type 2A third parties shall be treated as KMC -originated traffic and KMC shall compensate BellSouth for transport and termination of such traffic based on the classification of such traffic as Local Traffic, ISP-Bound Traffic, or Switched Access Traffic in accordance with the terms of this Attachment.
- 10.10.6 [Parties Disagree]

**[KMC Version]** BellSouth agrees to deliver Transit Traffic originated by <<customer\_short\_name>> to the terminating carrier; provided, however, that <<customer\_short\_name>> is solely responsible for negotiating and executing any appropriate contractual agreements with the terminating carrier for the exchange of Transit Traffic through the BellSouth network. BellSouth will not be liable for any compensation to the terminating carrier or to <<customer\_short\_name>> for transiting <<customer\_short\_name>>-originated or terminated Transit Traffic. In the event that the terminating third party carrier imposes on BellSouth any charges or costs for the delivery of Transit Traffic originated by <<customer\_short\_name>>, <<customer\_short\_name>> shall reimburse BellSouth for all charges paid by BellSouth, **which BellSouth is contractually obligated to pay**, provided that BellSouth notifies and, upon request, provides <<customer\_short\_name>> with a copy of such an invoice, if available, or other equivalent supporting documentation (if an invoice is not available), and proof of payment and other applicable supporting documentation. BellSouth will provide such notice and information in a timely, reasonable and nondiscriminatory manner. BellSouth shall diligently review, dispute and pay such third party invoices (or equivalent) in a manner that is at parity with its own practices for reviewing, disputing and paying such invoices (or equivalent) **when no similar reimbursement provision applies**. Additionally, the Parties agree that any billing to a third party or other telecommunications carrier under this section shall be pursuant to MECAB procedures.

**[BellSouth Version]** BellSouth agrees to deliver Transit Traffic originated by <<customer\_short\_name>> to the terminating carrier; provided, however, that <<customer\_short\_name>> is solely responsible for negotiating and executing any appropriate contractual agreements with the terminating carrier for the exchange of Transit Traffic through the BellSouth network. BellSouth will not be liable for any compensation to the terminating carrier or to <<customer\_short\_name>> for transiting <<customer\_short\_name>>-originated or terminated Transit Traffic. In the event that the terminating third party carrier imposes on BellSouth any charges or costs for the delivery of Transit Traffic originated by <<customer\_short\_name>>, <<customer\_short\_name>> shall reimburse BellSouth for all charges paid by BellSouth, provided that BellSouth notifies <<customer\_short\_name>> **and, upon request, provides <<customer\_short\_name>> with a copy** of such an invoice, if available, or other equivalent supporting documentation (if an invoice is not available), and proof of payment and other applicable supporting documentation. BellSouth will use **commercially reasonable** efforts to provide such notice and information in a timely, reasonable and nondiscriminatory manner. BellSouth shall diligently review, dispute and pay such third party invoices (or equivalent) in a manner that is at parity with its own practices for reviewing, disputing and paying such invoices (or equivalent) **under the same circumstances. Once <<customer\_short\_name>> reimburses BellSouth for any such payments, any disputes with respect to such charges shall be between <<customer\_short\_name>> and the terminating third party carrier.**

Additionally, the Parties agree that any billing to a third party or other telecommunications carrier under this section shall be pursuant to MECAB procedures.

- 10.10.7 Except for as provided otherwise in this Attachment, transit charges as described in this Attachment shall only be assessed on the carrier originating Transit Traffic and shall not be assessed on the terminating carrier.
- 10.10.8 Transit charges associated with the provisioning of toll free services (e.g., 800/888/877) shall be assessed upon the terminating carrier and shall not be imposed on the originating carrier.
- 10.10.9 Exchange of Traffic Subject to Primary Toll Provider Arrangements
- 10.10.9.1 Where BellSouth is the primary toll provider for an Independent Company's ("ICO") end users (i.e. BellSouth receives the toll revenue paid by the end users) and where such ICO originates a toll call that transits BellSouth's network and is terminated by KMC, BellSouth and KMC will work cooperatively together to determine the appropriate amount of usage to be paid by BellSouth for such traffic. BellSouth shall route such traffic over transit traffic trunk groups, where technically feasible, and will pass appropriate OLI associated with these calls, where technically feasible. KMC will bill BellSouth at KMC's tariffed intrastate switched access rate or non-discriminatory web-posted listing if the FCC or Commission does not require filing of a tariff.
- 10.10.9.2 Where KMC originates traffic that is neither local traffic nor EAS traffic that transits BellSouth's network and it is terminated by and ICO and such ICO charges BellSouth switched access for the termination of such traffic, KMC agrees to reimburse BellSouth for the actual charges assessed by the ICO to BellSouth (and paid by BellSouth) for the KMC originated calls.
- 10.10.9.3 KMC and BellSouth agree to conduct a quarterly true-up in order to adjust for the appropriate ICO transit usage to be billed to or paid by each party.
- 10.10.10 Misrouting of Traffic.
- 10.10.10.1 The Parties shall route traffic to each other in a manner consistent with the Trunk Group Architectures selected by the Parties and as set forth in Section 4 of this Attachment 3, except as otherwise set forth in this Agreement (e.g., overflow) or in instances where a third party causes either Party to route traffic in a manner that is inconsistent with this Attachment.

- 10.10.10.2 In instances of misrouting, either Party may request that the Parties investigate, identify the cause of, and correct misrouting to the extent technically and economically feasible.
- 10.10.10.3 In the event that misrouting results in either Party's inability to bill or collect revenues from a third party and the Parties disagree as to the liability of the other Party for such revenues, then either Party may pursue the Dispute Resolution procedures set forth in this Agreement.
- 10.10.11 Records Exchange
  - 10.10.11.1 Where feasible and appropriate, the Parties will generate and exchange all available messages for the purpose of billing third parties, including but not limited to CMRS providers and other LECs.

## **11. FRAME RELAY SERVICE INTERCONNECTION**

- 11.1 In addition to the Local Interconnection services set forth above, BellSouth will offer a network to network Interconnection arrangement between BellSouth's and KMC's frame relay switches as set forth below. The following provisions will apply only to Frame Relay Service and Exchange Access Frame Relay Service and Managed Shared Frame Relay Service in those states in which KMC is certified and providing Frame Relay Service as a Local Exchange Carrier and where traffic is being exchanged between KMC and BellSouth Frame Relay Switches in the same LATA.
- 11.2 The Parties agree to establish two-way Frame Relay facilities between their respective Frame Relay Switches to the mutually agreed upon Frame Relay Service point(s) of interconnection (IP(s)) within the LATA. All IPs shall be within the same Frame Relay Network Serving Areas as defined in Section A40 of BellSouth's General Subscriber Service Tariff except as set forth in this Attachment.
- 11.3 Upon the request of either Party, such interconnection will be established where BellSouth and KMC have Frame Relay Switches in the same LATA. Where there are multiple Frame Relay switches in one central office, an interconnection with any one of the switches will be considered an interconnection with all of the switches at that central office for purposes of routing packet traffic.
- 11.4 The Parties agree to provision local and intraLATA Frame Relay Service and Exchange Access Frame Relay Service and Managed Shared Frame Relay

Service (both intrastate and interstate) over Frame Relay interconnection facilities between the respective Frame Relay switches and the IPs.

- 11.5 The Parties agree to assess each other reciprocal charges for the facilities that each provides to the other according to the Percent Local Circuit Use Factor (PLCU), determined as follows:
- 11.5.1 If the data packets originate and terminate in locations in the same LATA, and are consistent with the local definitions of the Agreement, the traffic is considered local. Frame Relay framed packet data is transported within Virtual Circuits (VC). For the purposes of this Agreement, if all the data packets transported within a VC remain within the LATA, then consistent with the local definitions in this Agreement, the traffic on that VC is local (Local VC).
- 11.5.2 If the originating and terminating locations of the two-way packet data traffic are not in the same LATA, the traffic on that VC is interLATA (InterLATA VC).
- 11.5.3 The PLCU is determined by dividing the total number of Local VCs, by the total number of VCs on each Frame Relay facility. To facilitate implementation, KMC may determine its PLCU in aggregate, by dividing the total number of Local VCs in a given LATA by the total number VCs in that LATA. The Parties agree to renegotiate the method for determining PLCU, at BellSouth's request, and within 90 days, if BellSouth notifies KMC that it has found that this method does not adequately represent the PLCU.
- 11.5.4 If there are no VCs on a facility when it is billed, the PLCU will be zero.
- 11.5.5 BellSouth will provide the circuit between the Parties' respective Frame Relay Switches. The Parties will be compensated as follows: BellSouth will invoice, and KMC will pay, the total nonrecurring and recurring charges for the circuit based upon the rates set forth in BellSouth's Interstate Access Tariff, FCC No. 1. KMC will then invoice, and BellSouth will pay, an amount calculated by multiplying the BellSouth billed charges for the circuit by one-half of KMC's PLCU.
- 11.6 The Parties agree to compensate each other for Frame Relay network-to-network interface (NNI) ports based upon the NNI rates set forth in BellSouth's Interstate Access Tariff, FCC No. 1. Compensation for each pair of NNI ports will be calculated as follows: BellSouth will invoice, and KMC will pay, the total nonrecurring and recurring charges for the NNI port. KMC will then invoice, and BellSouth will pay, an amount calculated by multiplying the BellSouth billed nonrecurring and recurring charges for the NNI port by KMC's PLCU.
- 11.7 Each Party agrees that there will be no charges to the other Party for its own subscriber's Permanent Virtual Circuit (PVC) rate elements for the local PVC segment from its Frame Relay switch to its own subscriber's premises. PVC rate

elements include the Data Link Connection Identifier (DLCI) and Committed Information Rate (CIR).

- 11.8 For the PVC segment between the KMC and BellSouth Frame Relay switches, compensation for the PVC charges is based upon the rates in BellSouth's Interstate Access Tariff, FCC No. 1.
- 11.9 Compensation for PVC rate elements will be calculated as follows:
- 11.9.1 If KMC orders a VC connection between a BellSouth subscriber's PVC segment and a PVC segment from the BellSouth Frame Relay switch to the KMC Frame Relay switch, BellSouth will invoice, and KMC will pay, the total nonrecurring and recurring PVC charges for the PVC segment between the BellSouth and KMC Frame Relay switches. If the VC is a Local VC, KMC will then invoice and BellSouth will pay, the total nonrecurring and recurring PVC charges billed for that segment. If the VC is not local, no compensation will be paid to KMC for the PVC segment.
- 11.9.2 If BellSouth orders a Local VC connection between a KMC subscriber's PVC segment and a PVC segment from the KMC Frame Relay switch to the BellSouth Frame Relay switch, BellSouth will invoice, and KMC will pay, the total nonrecurring and recurring PVC and CIR charges for the PVC segment between the BellSouth and KMC Frame Relay switches. If the VC is a Local VC, KMC will then invoice and BellSouth will pay the total nonrecurring and recurring PVC and CIR charges billed for that segment. If the VC is not local, no compensation will be paid to KMC for the PVC segment.
- 11.9.3 The Parties agree to compensate each other for requests to change a PVC segment or PVC service order record, according to the Feature Change charge as set forth in the BellSouth access tariff BellSouth Tariff FCC No. 1.
- 11.9.4 If KMC requests a change, BellSouth will invoice and KMC will pay a Feature Change charge for each affected PVC segment.
- 11.9.4.1 If BellSouth requests a change to a Local VC, KMC will invoice and BellSouth will pay a Feature Change charge for each affected PVC segment.
- 11.9.5 The Parties agree to limit the sum of the CIR for the VCs on a DS1 NNI port to not more than three times the port speed, or not more than six times the port speed on a DS3 NNI port.
- 11.9.6 Except as expressly provided herein, this Agreement does not address or alter in any way either Party's provision of Exchange Access Frame Relay Service, Managed Shared Frame Relay Service or interLATA Frame Relay Service. All charges by each Party to the other for carriage of Exchange Access Frame Relay Service or interLATA Frame Relay Service are included in the BellSouth access tariff BellSouth Tariff FCC No. 1.



11.10 KMC will identify and report quarterly to BellSouth the PLCU of the Frame Relay facilities it uses, per Section 11.5.3 above.

11.11 Either Party may request a review or audit of the various service components, consistent with the provisions of section E2 of the BellSouth State Access Services tariffs or Section 2 of the BellSouth FCC No.1 Tariff.

## **12. BASIC 911 AND E911 INTERCONNECTION**

12.1 Basic 911 and E911 provides a caller access to the applicable emergency service bureau by dialing 911.

12.2 Basic 911 Interconnection. BellSouth will provide to <<customer\_short\_name>> a list consisting of each municipality that subscribes to Basic 911 service. The list will also provide, if known, the E911 conversion date for each municipality and, for network routing purposes, a ten-digit directory number representing the appropriate emergency answering position for each municipality subscribing to 911. <<customer\_short\_name>> will be required to arrange to accept 911 calls from its end users in municipalities that subscribe to Basic 911 service and translate the 911 call to the appropriate 10-digit directory number as stated on the list provided by BellSouth. <<customer\_short\_name>> will be required to route the call to the appropriate PSAP. When a municipality converts to E911 service, <<customer\_short\_name>> will be required to begin using E911 procedures.

12.3 E911 Interconnection. <<customer\_short\_name>> shall install a minimum of two (2) dedicated trunks originating from its Serving Wire Center and terminating to the appropriate E911 tandem. The Serving Wire Center must be in the same LATA as the E911 tandem. The dedicated trunks shall be, at a minimum, DS0 level trunks configured as part of a digital (1.544 Mb/s) interface (DS1 facility). The configuration shall use CAMA-type signaling with multifrequency (MF) pulsing that will deliver ANI with the voice portion of the call. If the user interface is digital, MF pulses as well as other AC signals shall be encoded per the u-255 Law convention. <<customer\_short\_name>> will be required to provide BellSouth daily updates to the E911 database. <<customer\_short\_name>> will be required to forward 911 calls to the appropriate E911 tandem along with ANI based upon the current E911 end office to tandem homing arrangement as provided by BellSouth. If the E911 tandem trunks are not available, <<customer\_short\_name>> will be required to route the call to a designated seven (7)-digit or ten (10)-digit local number residing in the appropriate PSAP. This call will be transported over BellSouth's interoffice network and will not carry the ANI of the calling party. <<customer\_short\_name>> shall be responsible for providing BellSouth with complete and accurate data for submission to the 911/E911 database for the purpose of providing 911/E911 to its End Users.

- 12.4 Rates. Recurring and nonrecurring rates associated with trunk groups for 911 service are as set forth in Section 3.3.1 of this Attachment.
- 12.5 The detailed practices and procedures for 911/E911 interconnection are contained in the E911 Local Exchange Carrier Guide For Facility-Based Providers, which can be found at <http://www.interconnection.bellsouth.com/guides/e911/html/gcuge001/index.htm>.

Exhibit B

# Basic Architecture

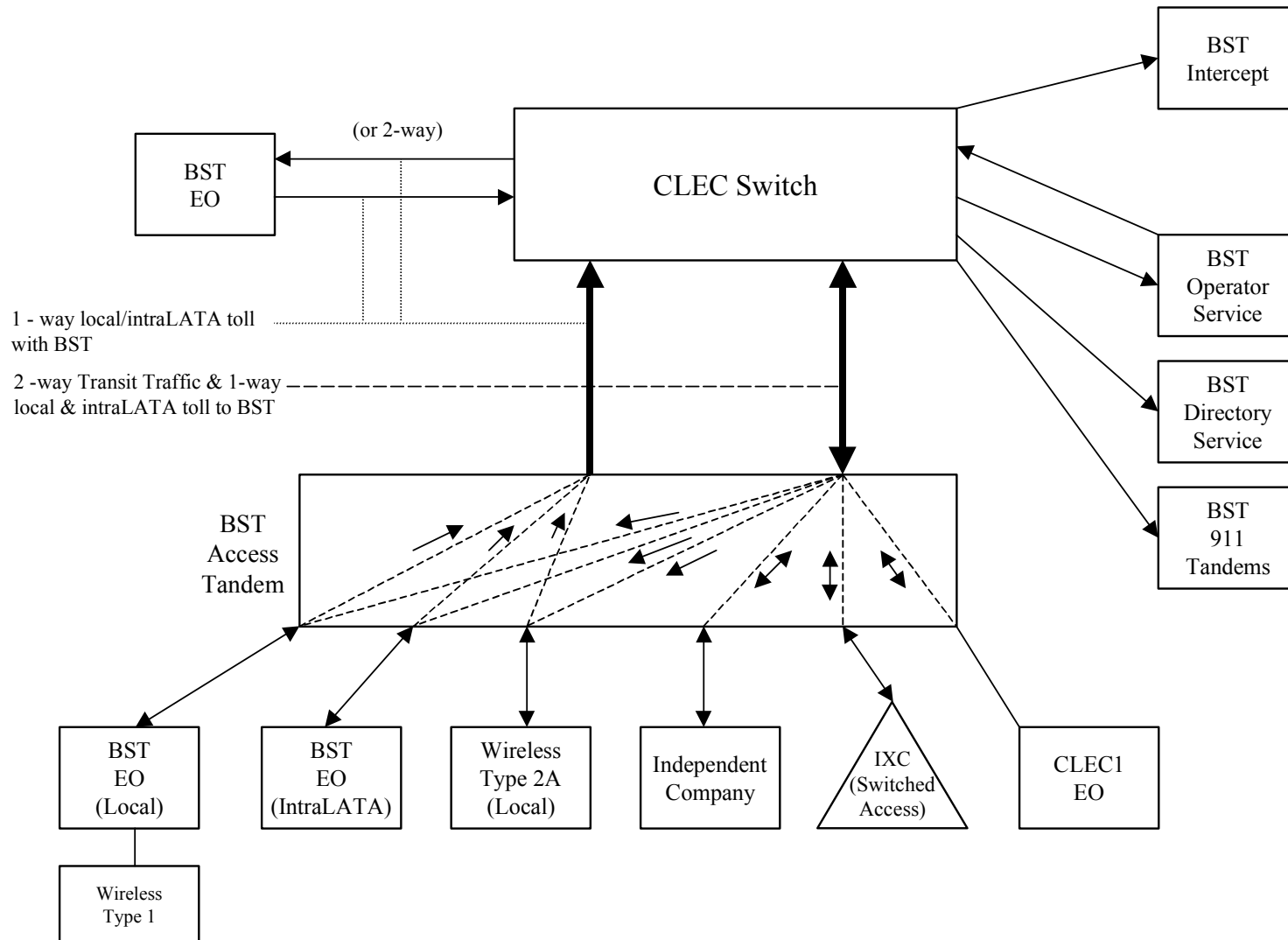

# One-Way Architecture

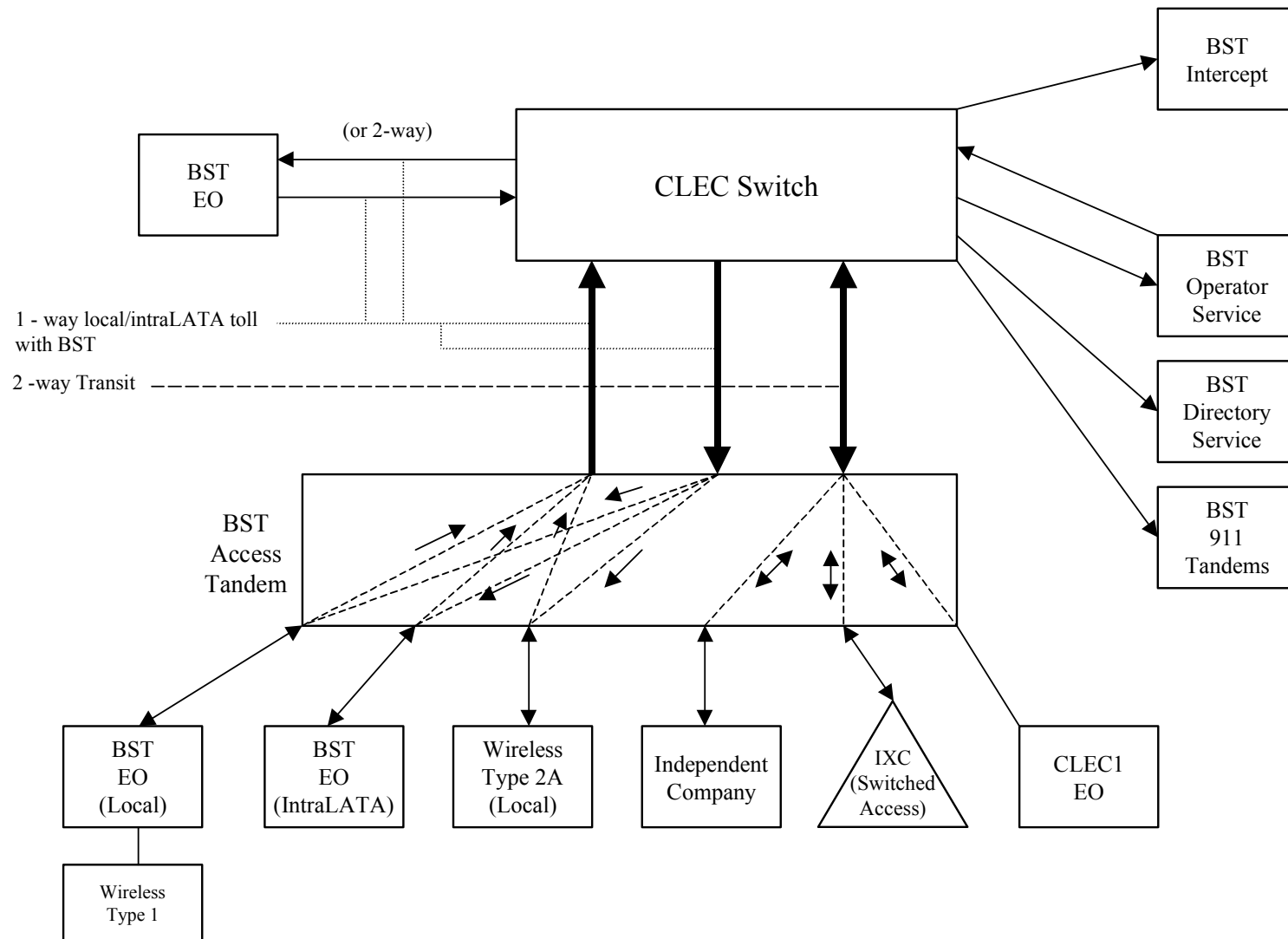

Exhibit D

# Two-Way Architecture

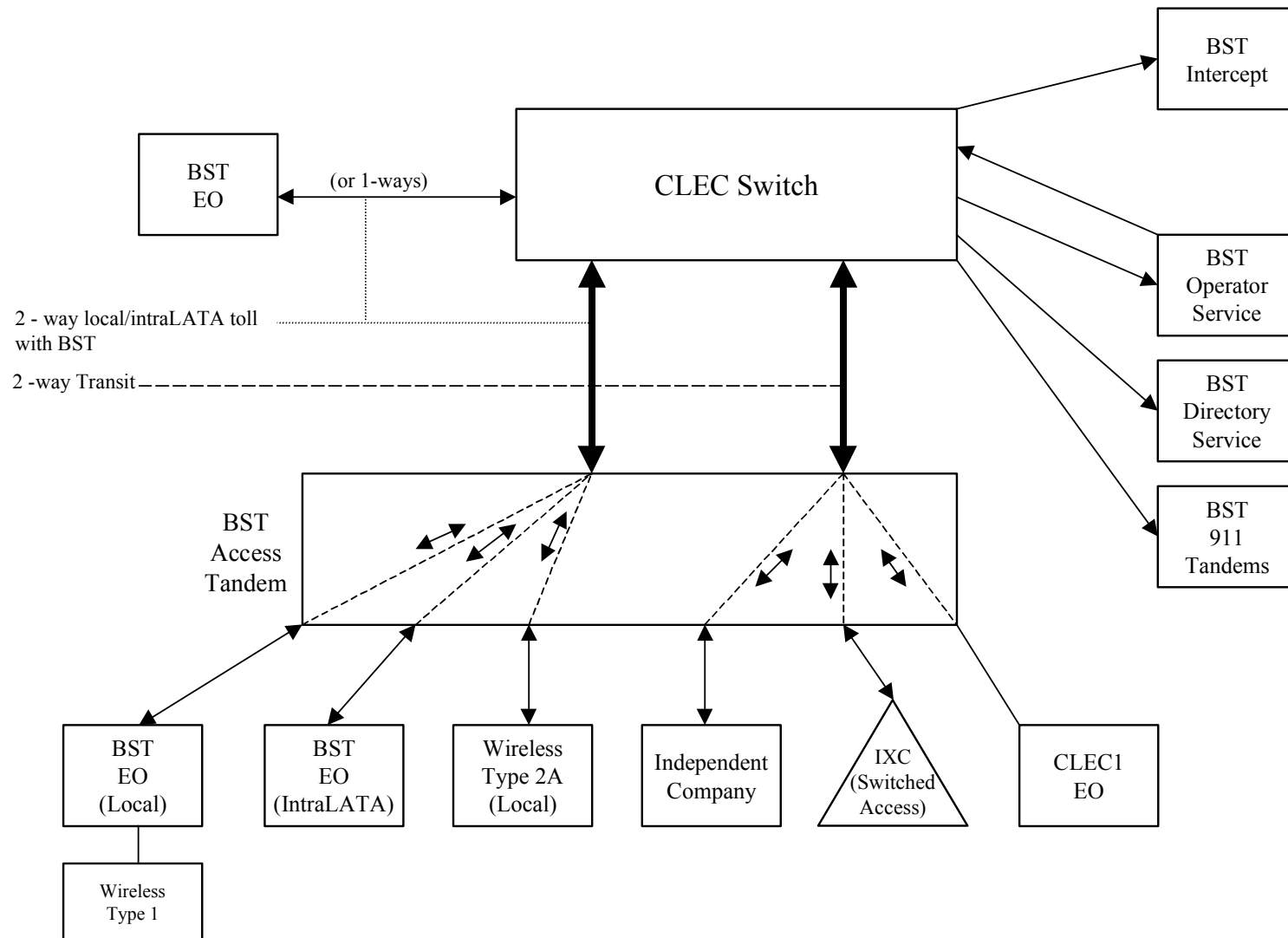
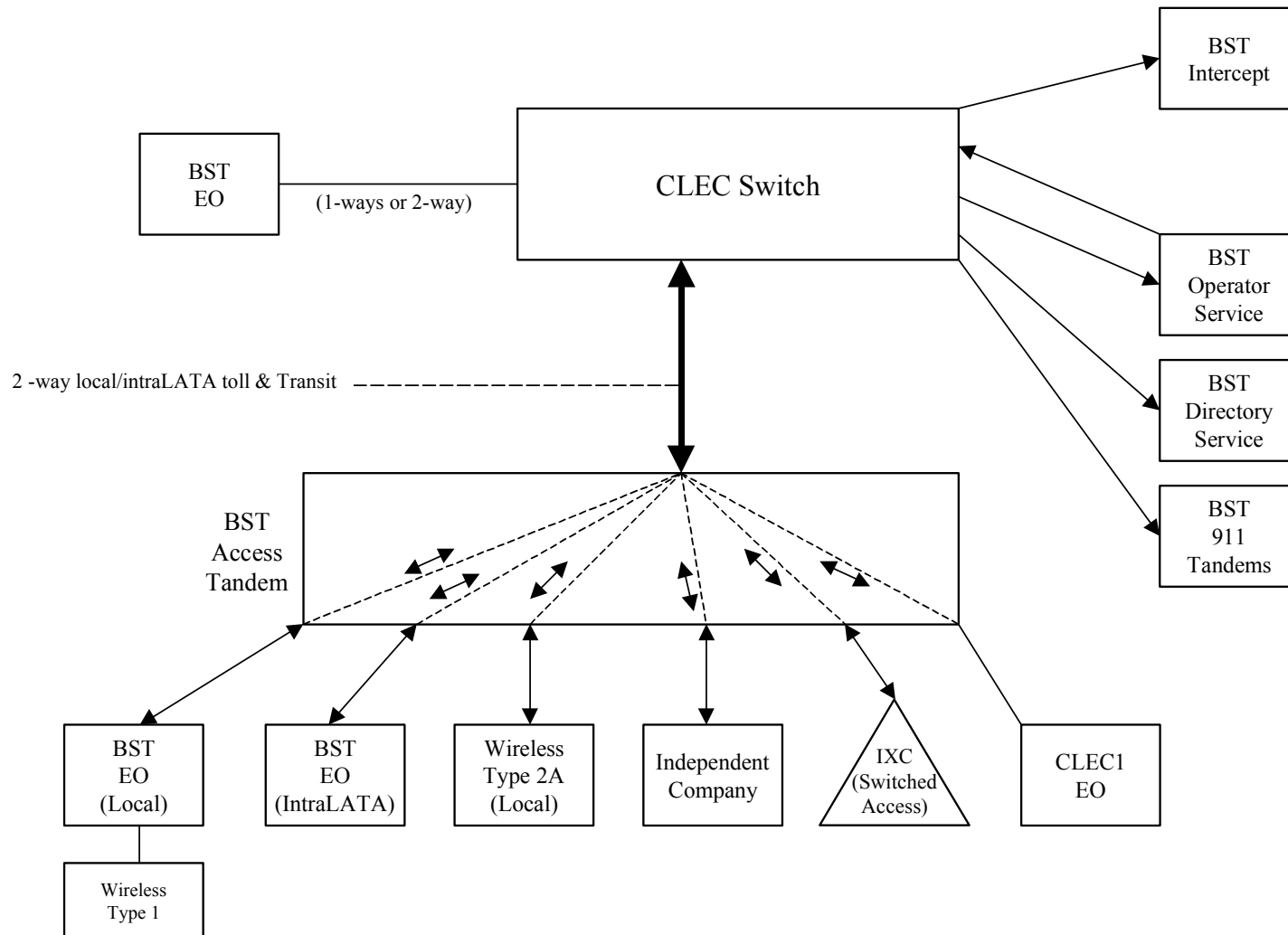

Exhibit E

# Supergroup Architecture



LOCAL INTERCONNECTION - Kentucky											Attachment: 3			Exhibit: A		
CATEGORY	UNBUNDLED NETWORK ELEMENT	Interim	Zone	BCS	USOC	RATES (\$)				OSS RATES (\$)						
						Rec	Nonrecurring		Nonrecurring Disconnect		Svc Order Submitted Elec per LSR SOMEK	Svc Order Submitted Manually per LSR SOMAN	Incremental Charge - Manual Svc Order vs. Electronic-1st SOMAN	Incremental Charge - Manual Svc Order vs. Electronic-Add'l SOMAN	Incremental Charge - Manual Svc Order vs. Electronic-Disc 1st SOMAN	Incremental Charge - Manual Svc Order vs. Electronic-Disc Add'l SOMAN
							First	Add'l	First	Add'l						
<b>LOCAL INTERCONNECTION (CALL TRANSPORT AND TERMINATION)</b>																
<b>END OFFICE SWITCHING</b>																
	End Office Switching Function, Per MOU			OHD		0.0014083										
<b>TANDEM SWITCHING</b>																
	Tandem Switching Function Per MOU			OHD		0.0006772										
	Multiple Tandem Switching, per MOU (applies to intial tandem only)			OHD		0.0006772										
	Tandem Intermediary Charge, per MOU*			OHD		0.0015										
* This charge is applicable only to transit traffic and is applied in addition to applicable switching and/or interconnection charges.																
<b>TRUNK CHARGE</b>																
	Installation Trunk Side Service - per DS0			OHD	TPP++	334.09	57.12									
	Dedicated End Office Trunk Port Service-per DS0**			OHD	TDE0P	0.00										
	Dedicated End Office Trunk Port Service-per DS1**			OH1 OH1MS	TDE1P	0.00										
	Dedicated Tandem Trunk Port Service-per DS0**			OHD	TDW0P	0.00										
	Dedicated Tandem Trunk Port Service-per DS1**			OH1 OH1MS	TDW1P	0.00										
** This rate element is recovered on a per MOU basis and is included in the End Office Switching and Tandem Switching, per MOU rate elements.																
<b>COMMON TRANSPORT (Shared)</b>																
	Common Transport - Per Mile, Per MOU			OHD		0.000003										
	Common Transport - Facilities Termination Per MOU			OHD		0.0007466										
<b>LOCAL INTERCONNECTION (TRANSPORT)</b>																
<b>INTEROFFICE CHANNEL - DEDICATED TRANSPORT - VOICE GRADE</b>																
	Interoffice Channel - Dedicated Transport - 2-Wire Voice Grade - Per Mile per month			OHL, OHM	1L5NF	0.01										
	Interoffice Channel - Dedicated Transport- 2- Wire Voice Grade - Facility Termination per month			OHL, OHM	1L5NF	29.11	47.34		22.77							
<b>INTEROFFICE CHANNEL - DEDICATED TRANSPORT - 56/64 KBPS</b>																
	Interoffice Channel - Dedicated Transport - 56 kbps - per mile per month			OHL, OHM	1L5NK	0.0115										
	Interoffice Channel - Dedicated Transport - 56 kbps - Facility Termination per month			OHL, OHM	1L5NK	20.97	47.35		22.77							
	Interoffice Channel - Dedicated Transport - 64 kbps - per mile per month			OHL, OHM	1L5NK	0.0115										
	Interoffice Channel - Dedicated Transport - 64 kbps - Facility Termination per month			OHL, OHM	1L5NK	20.97	47.35		22.77							
<b>INTEROFFICE CHANNEL - DEDICATED TRANSPORT - DS1</b>																
	Interoffice Channel - Dedicated Channel - DS1 - Per Mile per month			OH1, OH1MS	1L5NL	0.23										
	Interoffice Channel - Dedicated Transport - DS1 - Facility Termination per month			OH1, OH1MS	1L5NL	96.04	105.52		23.09							
<b>INTEROFFICE CHANNEL - DEDICATED TRANSPORT - DS3</b>																
	Interoffice Channel - Dedicated Transport - DS3 - Per Mile per month			OH3, OH3MS	1L5NM	4.97										
	Interoffice Channel - Dedicated Transport - DS3 - Facility Termination per month			OH3, OH3MS	1L5NM	1,175.15	335.40		89.57							
<b>LOCAL CHANNEL - DEDICATED TRANSPORT</b>																

LOCAL INTERCONNECTION - Kentucky											Attachment: 3		Exhibit: A				
CATEGORY	UNBUNDLED NETWORK ELEMENT	Interim	Zone	BCS	USOC	RATES (\$)				OSS RATES (\$)							
						Rec	Nonrecurring		Nonrecurring Disconnect		Svc Order Submitted Elec per LSR	Svc Order Submitted Manually per LSR	Incremental Charge - Manual Svc Order vs. Electronic-1st	Incremental Charge - Manual Svc Order vs. Electronic-Disc Add'l	Incremental Charge - Manual Svc Order vs. Electronic-Disc 1st	Incremental Charge - Manual Svc Order vs. Electronic-Disc Add'l	
							First	Add'l	First	Add'l							SOMECS
	Local Channel - Dedicated - 2-Wire Voice Grade per month			OHL, OHM	TEFV2	18.57	265.78	46.96	46.79	4.98							
	Local Channel - Dedicated - 4-Wire Voice Grade per month			OHL, OHM	TEFV4	19.86	266.48	47.65	47.54	5.73							
	Local Channel - Dedicated - DS1 per month			OH1	TEFHG	40.46	209.60	176.51	30.21	21.07							
	Local Channel - Dedicated - DS3 Facility Termination per month			OH3	TEFHJ	576.05	551.38	338.08	173.00	120.42							
<b>LOCAL INTERCONNECTION MID-SPAN MEET</b>																	
<b>NOTE: If Access service ride Mid-Span Meet, one-half the tariffed service Local Channel rate is applicable.</b>																	
	Local Channel - Dedicated - DS1 per month			OH1MS	TEFHG	0.00	0.00										
	Local Channel - Dedicated - DS3 per month			OH3MS	TEFHJ	0.00	0.00										
<b>MULTIPLEXERS</b>																	
	Channelization - DS1 to DS0 Channel System			OH1, OH1MS	SATN1	113.33	101.40	71.60	13.79	13.04							
	DS3 to DS1 Channel System per month			OH3, OH3MS	SATNS	158.20	199.23	118.62	50.16	48.59							
	DS3 Interface Unit (DS1 COC) per month			OH1, OH1MS	SATCO	11.80	10.07	7.08									



**Attachment 3**  
**Network Interconnection**

**TABLE OF CONTENTS**

**1. GENERAL.....3**

**2. DEFINITIONS: (FOR THE PURPOSE OF THIS ATTACHMENT) .....3**

**3. NETWORK INTERCONNECTION .....4**

**4. INTERCONNECTION TRUNK GROUP ARCHITECTURES.....8**

**5. NETWORK DESIGN AND MANAGEMENT FOR INTERCONNECTION .....16**

**6. SIGNALING.....17**

**7. FORECASTING FOR TRUNK PROVISIONING .....25**

**8. TRUNK UTILIZATION .....27**

**9. INTERFERENCE OR IMPAIRMENT.....28**

**10. COMPENSATION FOR CALL TRANSPORT AND TERMINATION FOR LOCAL TRAFFIC AND ISP-BOUND TRAFFIC. .....30**

**11. BASIC 911 AND E911 INTERCONNECTION.....39**

**12. FRAME RELAY SERVICE INTERCONNECTION .....40**

<b>Rates</b>	<b>Exhibit A</b>
<b>Basic Architecture</b>	<b>Exhibit B</b>
<b>One Way Architecture</b>	<b>Exhibit C</b>
<b>Two Way Architecture</b>	<b>Exhibit D</b>
<b>Supergroup Architecture</b>	<b>Exhibit E</b>

## NETWORK INTERCONNECTION

### 1. GENERAL

1.1 The Parties shall provide interconnection with each other's networks for the transmission and routing of telephone exchange service and exchange access on the following terms:

### 2. DEFINITIONS: (FOR THE PURPOSE OF THIS ATTACHMENT)

2.1 For purposes of this attachment only, the following terms shall have the definitions set forth below:

2.1.1 **Call Termination** has the meaning set forth for "termination" in 47 CFR § 51.701(d).

2.1.2 **Call Transport** has the meaning set forth for "transport" in 47 CFR § 51.701(c).

2.1.3 **Call Transport and Termination** is used collectively to mean the switching and transport functions from the Interconnection Point to the last point of switching.

2.1.4 **Common (Shared) Transport** is defined as the transport of the originating Party's traffic by the terminating Party over the terminating Party's common (shared) facilities between (1) the terminating Party's tandem switch and end office switch, (2) between the terminating Party's tandem switches, and/or (3) between the terminating Party's host and remote end office switches. All switches referred to herein must be registered in the Local Exchange Routing Guide (LERG).

2.1.5 **Cross Connect** is as defined in Attachment 4 of the Interconnection Agreement. If a Party provisions a cross connect for the purposes of interconnection under this Attachment 3, and such cross connect is not associated with a physical or virtual collocation arrangement, the provisioning party shall not charge for such cross connect.

2.1.6 **Dedicated Interoffice Facility** is defined as a switch transport facility between a Party's Serving Wire Center and the first point of switching within the LATA on the other Party's network.

2.1.7 **End Office Switching** is defined as the function that establishes a communications path between the trunk side and line side of the End Office switch.

2.1.8 **Fiber Meet** is an interconnection arrangement whereby the Parties physically interconnect their networks via an optical fiber interface at which one Party's facilities, provisioning, and maintenance responsibility begins and the other Party's responsibility ends.

- 2.1.9 **Interconnection Point (IP)** is a physical telecommunications equipment interface that interconnects the networks of BellSouth and <<customer\_short\_name>>.
- 2.1.10 **ISP-Bound Traffic** is calls to an information service provider/enhanced service provider or Internet service provider (ISP) that are dialed by using a local dialing pattern (7 or 10 digits).
- 2.1.11 **Local Channel** is defined as a switched transport facility between a Party's Point of Presence and its designated Serving Wire Center where the Point of Presence is not located within the designated Serving Wire Center
- 2.1.12 **Local Traffic** is defined as any traffic that is originated by an end user of one Party and is terminated to an end user of the other Party within a given LATA on that other Party's network, except for those calls that are originated or terminated through switched access arrangements. Additionally, Local Traffic includes any cross boundary, intrastate, interLATA or interstate interLATA calls established as a local call by the ruling regulatory body.
- 2.1.13 A **Point of Presence** is the physical location at which a Party establishes itself for obtaining access to the other Party's network.
- 2.1.14 **Reciprocal Trunk Group** is defined as a one-way trunk group carrying BellSouth originated traffic to be terminated by <<customer\_short\_name>>.
- 2.1.15 **Serving Wire Center** is defined as the wire center owned or leased by one Party that is designated by that Party to serve the geographic area in which the other Party's POP is located.
- 2.1.6 **Tandem Switching** is defined as the function that establishes a communications path between two switching offices through a third switching office through the provision of trunk side to trunk side switching.
- 2.1.7 **Transit Traffic** is traffic originating on one Party's network that is switched and/or transported by the other Party and delivered to a third party's network, or traffic originating on a third party's network that is switched and/or transported by one Party and delivered to the other Party's network.

### 3. NETWORK INTERCONNECTION

- 3.1 This Attachment pertains only to the provision of network interconnection where <<customer\_short\_name>> owns, leases from a third party or otherwise provides its own switch(es).
- 3.2 Network interconnection may be provided by the Parties via any technically feasible method and at any technically feasible point or points in accordance with applicable FCC and Commission rules and orders. In accordance with the terms of this Agreement, network interconnection may be provided via a DS0 where

technically feasible and supported by applicable industry standards. Requests for interconnection via methods, such as OCN level interconnection, other than as set forth in this Attachment may be made through the Bona Fide Request (BFR) process set out in Attachment 11 to this Agreement.

- 3.2.1 Requests for interconnection at a point or points other than as set forth in this Attachment may be made through the Bona Fide Request (BFR) process set out in Attachment 11 to this Agreement. At such time that BellSouth submits a request for interconnection that meets the requirements of this section, the Parties will negotiate the rates, terms, and conditions for such request.
- 3.2.2 Each Party is responsible for providing, engineering and maintaining the network on its side of the IP. The IP must be located within BellSouth's serving territory on BellSouth's network, or as otherwise mutually agreed by the Parties, in the LATA in which traffic is originating. The IP determines the point at which the originating Party shall pay the terminating Party for the Call Transport and Termination of Local Traffic and ISP-Bound Traffic.
- 3.2.3 Pursuant to the provisions of this Attachment, the Parties will endeavor in good faith to mutually agree on the location of the initial IP(s) in a given LATA. Both Parties will act in good faith and shall consider points that are efficient for both Parties. If the Parties are unable to agree on the location of the initial IP, in accordance with the terms and conditions set forth in this Attachment each Party may designate a single IP in the LATA for the delivery of Transit Traffic, Local Traffic originated by the other Party and ISP-bound Traffic originated by the other Party. BellSouth will not request the establishment of an IP where physical or virtual collocation space is not available or where BellSouth fiber connectivity is not available.
- 3.2.4 Additional IP(s) in a LATA may be established by mutual agreement of the Parties. Unless mutually agreed otherwise, an additional IP must be established if the following criteria are satisfied: (1) the traffic between <<customer\_short\_name>> and BellSouth at the proposed additional IP must exceed 8.9 million minutes of Local Traffic and ISP-Bound Traffic per month for three consecutive months; and (2) any end office to be designated as an additional IP must be more than 20 miles from an existing IP. BellSouth will not request the establishment of an IP where physical or virtual collocation space is not available or where BellSouth fiber connectivity is not available.
- 3.2.4.1 Upon written notification from the Party requesting the establishment of an additional IP, the receiving Party has twenty (20) business days to analyze, respond to, and negotiate in good faith regarding the establishment of such IP. Should the Parties disagree on how to proceed, the requesting Party may resort to the Dispute Resolution process set forth in the General Terms and Conditions.

- 3.2.5 When the Parties agree to utilize two-way interconnection trunk groups for the exchange of Local Traffic and ISP-bound Traffic the Parties must agree to the location of the IP(s).
- 3.2.6 Notwithstanding any other provision of this Attachment and subject to the requirements for installing additional IPs, as set forth above, any IPs existing prior to the Effective Date of the Agreement will be accepted as initial IPs. BellSouth will not require re-grooming however, <<customer\_short\_name>> may regroom and augment such IPs.

### 3.3 **Interconnection via Dedicated Facilities**

- 3.3.1 With the exception of Transit Traffic, the Parties shall institute a “bill and keep” compensation plan under which neither Party will charge the other Party recurring and nonrecurring charges for trunks (one-way or two-way), trunk ports and associated dedicated facilities for the exchange of Local Traffic (non-transit) and ISP-bound Traffic (non-transit), and 911 traffic. The appropriate rate elements that are subject to this “bill and keep” compensation plan are set forth in Exhibit A to this Attachment. Each Party has the obligation to install and maintain the appropriate trunks, trunk ports and associated facilities on its respective side of the IP and is responsible for bearing its costs for such trunks, trunk ports and associated facilities on its side of the IP. Both Parties, as appropriate, shall be compensated for the ordering of trunks, trunk ports and facilities used exclusively for Transit Traffic and for ancillary traffic types including, but not limited to, OS/DA. The Parties agree that charges for such trunks, trunk ports and facilities are as set forth in Exhibit A to this Attachment or to the extent a rate associated with the interconnecting trunk group is not set forth in Exhibit A, the rate shall be as set forth in the appropriate Party’s tariff as filed and effective with the FCC or Commission, or reasonable and non-discriminatory web-posted listing if the FCC or Commission does not require filing of a tariff.
- 3.3.2 **Local Channel Facilities.** In lieu of providing facilities on its side of Interconnection Point or as part of Call Transport and Termination, either Party may purchase Local Channel facilities from the other Party, pursuant to the provisions of this Attachment, where such facilities are available. The percentage of Local Channel Facilities utilized for Local Traffic and ISP-bound Traffic shall be determined based upon the application of the Percent Local Facility (PLF) Factor on a statewide basis. The charges applied to the percentage of Local Channel facilities used for Local Traffic and ISP-bound Traffic as determined by the PLF are set forth in Section 3.3.1 above. The remaining percentage of Local Channel Facilities shall be billed at the appropriate Party’s intrastate or interstate tariff rates for switched access services or reasonable and non-discriminatory web-posted listing if the FCC or Commission does not require filing of a tariff.

3.3.3 **Dedicated Interoffice Facilities**. In lieu of providing facilities on its side of Interconnection Point or as part of Call Transport and Termination, either Party may purchase Dedicated Interoffice facilities from the other Party, pursuant to the provisions of this Attachment, where such facilities are available. The percentage of Dedicated Interoffice Facilities utilized for Local Traffic and ISP-bound Traffic shall be determined based upon the application of the Percent Local Facility (PLF) Factor on a statewide basis. The charges applied to the percentage of Dedicated Interoffice facilities used for Local Traffic and ISP-bound Traffic as determined by the PLF are set forth in Section 3.3.1 above. The remaining percentage of the Dedicated Interoffice Facilities shall be billed at the appropriate Party's intrastate or interstate tariff rates for switched access services or reasonable and non-discriminatory web-posted listing if the FCC or Commission does not require filing of a tariff.

3.3.4 [Parties Disagree]

[NewSouth Version] In the event that a Party's Point of Presence is located within any serving wire center (i.e., switch location), such Party may interconnect to the other Party's switch via a Cross Connect or any other technically feasible means of interconnection.

[BellSouth Version] If a Party provisions a cross connect for the purposes of interconnection under this Attachment 3, and such cross connect is not associated with a physical or virtual collocation arrangement, the provisioning party shall not charge for such cross connect.

3.3.5 The facilities and associated components as set forth in Exhibit A of this Attachment purchased pursuant to this Section 3 shall be ordered via the Access Service Request (ASR) process. The terms, conditions and rates for ordering charges (i.e., expedite, cancellation, and order modification charges) are as set forth in the BellSouth FCC Tariff No. 1. To the extent that BellSouth requests that <<customer\_short\_name>> submit an ASR for an augmentation to the facilities purchased by <<customer\_short\_name>> from BellSouth but utilized for BellSouth's originated traffic, the Parties will work in good faith and make best efforts to ensure that the ASR submitted for such augmentations does not require expedition, cancellation or modification and in the event that <<customer\_short\_name>> incurs ordering charges, BellSouth and <<customer\_short\_name>> shall work cooperatively to determine which Party caused the incurrence of such charges and that Party shall be responsible for such charges.

3.4 **Fiber Meet**

- 3.4.1 If <<customer\_short\_name>> elects to establish interconnection with BellSouth pursuant to a Fiber Meet Local Channel, <<customer\_short\_name>> and BellSouth shall jointly engineer, operate and maintain a Synchronous Optical Network (SONET) transmission system by which they shall interconnect their transmission and routing of Local Traffic via a Local Channel at either the, DS10, DS1, or DS3 level. The Parties shall work jointly to determine the specific transmission system. However, <<customer\_short\_name>>'s SONET transmission system must be compatible with BellSouth's equipment, and the Data Communications Channel (DCC) must be turned off, unless otherwise mutually agreed to by the Parties.
- 3.4.2 Each Party, at its own expense, shall procure, install and maintain the agreed upon SONET transmission system in its network.
- 3.4.3 The Parties shall agree to a Fiber Meet point between the BellSouth Serving Wire Center and the <<customer\_short\_name>> Serving Wire Center. The Parties shall deliver their fiber optic facilities to the Fiber Meet point with sufficient spare length to reach the fusion splice point for the Fiber Meet Point. BellSouth shall, at its own expense, provide and maintain the fusion splice point for the Fiber Meet. A building type Common Language Location Identification (CLLI) code will be established for each Fiber Meet point. All orders for interconnection facilities from the Fiber Meet point shall indicate the Fiber Meet point as the originating point for the facility.
- 3.4.4 Upon verbal request by <<customer\_short\_name>> and within a reasonable and non-discriminatory timeframe, BellSouth shall allow <<customer\_short\_name>> access to the fusion splice point for the Fiber Meet point for maintenance purposes on <<customer\_short\_name>>'s side of the Fiber Meet point.
- 3.4.5 Neither Party shall charge the other for its Local Channel portion of the Fiber Meet facility used for Local Traffic and ISP-bound Traffic. The remaining portion of the Local Channel shall be billed at the appropriate Party's intrastate or interstate tariff rates for switched access services or reasonable and non-discriminatory web-posted listing if the FCC or Commission does not require filing of a tariff.

#### **4. INTERCONNECTION TRUNK GROUP ARCHITECTURES**

- 4.1 BellSouth and <<customer\_short\_name>> shall establish interconnecting trunk groups and trunk group configurations between networks, including the use of one-way or two-way trunks in accordance with the following provisions set forth in this Attachment. For trunking purposes, traffic will be routed based on the digits dialed by the originating End User and in accordance with the LERG.
- 4.2 <<customer\_short\_name>> shall establish an interconnection trunk group(s) to at least one BellSouth access tandem within the LATA for the delivery of



<<customer\_short\_name>>'s originated Local Traffic, ISP-bound Traffic and IntraLATA Toll Traffic and for the receipt and delivery of Transit Traffic. To the extent <<customer\_short\_name>> desires to deliver Local Traffic, ISP-bound Traffic, IntraLATA Toll Traffic and/or Transit Traffic to BellSouth access tandems within the LATA, other than the tandems(s) to which <<customer\_short\_name>> has established interconnection trunk groups, <<customer\_short\_name>> shall order Multiple Tandem Access, as described in this Attachment, to such other BellSouth access tandems.

- 4.2.1 Notwithstanding the forgoing, <<customer\_short\_name>> shall establish an interconnection trunk group(s) to all BellSouth access and local tandems in the LATA where <<customer\_short\_name>> has homed (i.e., assigned) its NPA/NXXs. <<customer\_short\_name>> shall home its NPA/NXXs on the BellSouth tandems that serve the exchange rate center areas to which the NPA/NXXs are assigned. The specified exchange rate center assigned to each BellSouth tandem is defined in the LERG. <<customer\_short\_name>> shall enter its NPA/NXX access and/or local tandem homing arrangements into the LERG.
- 4.3 Switched access traffic will be delivered to and from Interexchange Carriers (IXCs) based on <<customer\_short\_name>>'s NXX access tandem homing arrangement as specified by <<customer\_short\_name>> in the LERG.
- 4.4 Any <<customer\_short\_name>> interconnection request that (1) deviates from the interconnection trunk group architectures as described in this Agreement, (2) affects traffic delivered to <<customer\_short\_name>> from a BellSouth switch and (3) requires special BellSouth -switch translations and other network modifications will require <<customer\_short\_name>> to follow the procedures set forth in Attachment 11 to this Agreement. At such time that BellSouth submits a request for interconnection that meets the requirements of this section, the Parties will negotiate the rates, terms, and conditions for such request.
- 4.5 Unless the Parties mutually agree otherwise, <<customer\_short\_name>> shall be responsible for ordering and paying for any two way trunks carrying Transit Traffic. At such time as <<customer\_short\_name>> is providing the transit function for 15% or more of all Transit Traffic, <<customer\_short\_name>> will provide BellSouth with notification and supporting documentation that such threshold has been met. Within fifteen days following BellSouth's receipt of such notification and documentation, the Parties will begin negotiations for an alternative compensation arrangement for such two-way trunks carrying Transit Traffic. If the Parties are unable to agree to an alternative compensation arrangement within forty-five days of BellSouth's receipt of notification, then the Parties shall mutually agree to extend the negotiations or, absent mutual agreement, the Parties shall refer to the Dispute Resolution procedure set forth in this Agreement. Upon agreement of such alternative compensation arrangement, the Parties shall execute an amendment implementing such alternative

compensation for two way trunks carrying Transit Traffic and the Parties shall “true-up” such arrangement to the date BellSouth received notification.

- 4.6 All trunk groups will be provisioned as Signaling System 7 (SS7) capable where technically feasible. If SS7 is not technically feasible, multi-frequency (MF) protocol signaling shall be used.
- 4.7 In cases where <<customer\_short\_name>> is also an IXC, the IXC’s Feature Group D (FG D) trunk group(s) must remain separate from the local interconnection trunk group(s).
- 4.8 **One-Way Interconnection Trunks and Trunk Groups.** Each Party shall order one-way interconnection trunks and trunk groups, including trunk and trunk group augmentations, via the ASR process. A Firm Order Confirmation (FOC) shall be returned to the ordering Party, after receipt of a valid, error free ASR, within the timeframes set forth in Attachment 6, if applicable. Notwithstanding the foregoing, blocking situations and projects shall be project managed through BellSouth’s Carrier Interconnection Switching Center (CISC) Project Management Group and <<customer\_short\_name>>’s equivalent trunking group and FOCs for such orders shall be returned in the timeframes negotiated by the Parties and suitable to the project. No additional charges shall be triggered due to the involvement of such project management. A project is defined as (1) a new trunk group (excluding augments to existing routes) or (2) a request for more than 96 trunks on a single or multiple group(s) in a given BellSouth local calling area.
- 4.9 **Two-Way Interconnection Trunks and Trunk Groups.** Upon mutual agreement of the Parties, the Parties’ shall exchange Local Traffic and ISP-Bound Traffic, and Transit Traffic, where applicable, on two-way interconnection trunk group(s) with the quantity of trunks being mutually determined and the provisioning being jointly coordinated. Furthermore, the Parties shall agree upon the IP(s) for two-way interconnection trunk groups transporting both Parties’ Local Traffic, ISP-Bound Traffic and Transit Traffic, where applicable, consistent with Section 3 above . Upon determination by the Parties in a joint planning meeting that such trunk groups shall be utilized, <<customer\_short\_name>> shall order such two-way trunks, and any subsequent trunk and trunk group augmentations, via the Access Service Request (ASR) process. BellSouth will use the Trunk Group Service Request (TGSR) and/or submit a request to <<customer\_short\_name>> via email or phone (with e-mail confirmation) to request changes in trunking to <<customer\_short\_name>>’s two-way trunk groups carrying BellSouth originated traffic. A Firm Order Confirmation (FOC) shall be returned to the ordering Party, after receipt of a valid, error free ASR, within the applicable timeframes as set forth in Attachment 6, if applicable. Notwithstanding the foregoing, blocking situations and projects shall be project managed through BellSouth’s Carrier Interconnection Switching Center (CISC) Project Management Group and <<customer\_short\_name>>’s equivalent trunking group and FOCs for such orders shall be returned in the timeframes negotiated by

the Parties and suitable to the project. No additional charges shall be triggered due to the involvement of such project management. A project is defined as (1) a new trunk group (excluding augments to existing routes) or (2) a request for more than 96 trunks on a single or multiple group(s) in a given BellSouth local calling area. Furthermore, the Parties shall jointly review trunk performance and forecasts on a periodic basis, as set forth in Section 5.7 of this Attachment. The Parties' use of two-way interconnection trunk groups for the transport of Local Traffic, ISP-Bound Traffic and Transit Traffic, where applicable, between the Parties does not preclude the Parties from mutually agreeing to establish additional one-way interconnection trunks for the delivery of either Party's originated Local Traffic, ISP-Bound Traffic, and Transit Traffic to the other Party where necessary, however, the proposal to establish such one-ways will be discussed by the parties prior to the submission of an ASR.

#### 4.9.1 **BellSouth Access Tandem Interconnection**

Interconnection at a single access tandem provides access to those end offices subtending that access tandem (Intratandem Access). Access tandem interconnection is available for any of the following access tandem architectures:

##### 4.9.1.1 **Basic Architecture**

In the Basic Architecture, <<customer\_short\_name>>'s originating Local Traffic, ISP-bound Traffic and IntraLATA Toll Traffic and originating and terminating Transit Traffic is transported on a single two-way trunk group between <<customer\_short\_name>> and BellSouth access tandem(s) within a LATA to provide Intratandem Access. This trunk group carries Transit Traffic between <<customer\_short\_name>> and Independent Companies, Interexchange Carriers, other CLECs, and CMRS providers that have a Meet Point Billing arrangement with BellSouth, and other network providers with which <<customer\_short\_name>> desires to exchange traffic. This trunk group also carries <<customer\_short\_name>> originated Transit Traffic transiting a single BellSouth access tandem destined to third party tandems such as an Independent Company tandem or other CLEC tandem. BellSouth originated Local Traffic, ISP-bound Traffic and IntraLATA Toll Traffic is transported on a separate single one-way trunk group terminating to <<customer\_short\_name>>. Other trunk groups for operator services, directory assistance, and intercept may be established pursuant to the applicable BellSouth tariff if service is requested. The LERG shall be referenced for current routing and tandem serving arrangements. The Basic Architecture is illustrated in Exhibit B.

##### 4.9.1.2 **One-Way Trunk Group Architecture**

In One-Way Trunk Group architecture, the Parties interconnect using three separate trunk groups. A one-way trunk group provides Intratandem Access for <<customer\_short\_name>>-originated Local Traffic, ISP-bound Traffic and IntraLATA Toll Traffic destined for BellSouth End Users. A second one-way trunk group carries BellSouth-originated Local Traffic, ISP-bound Traffic and

IntraLATA Toll Traffic destined for <<customer\_short\_name>> End-Users. A two-way trunk group provides Intratandem Access for <<customer\_short\_name>>'s originating and terminating Transit Traffic. This trunk group carries Transit Traffic between <<customer\_short\_name>> and Independent Companies, Interexchange Carriers, other CLECs, CMRS providers that have a Meet Point Billing arrangement with BellSouth, and other network providers with which <<customer\_short\_name>> desires to exchange traffic. This trunk group also carries <<customer\_short\_name>> originated Transit Traffic transiting a single BellSouth access tandem destined to third party tandems such as an Independent Company tandem or other CLEC tandem. BellSouth originated Local Traffic, ISP-bound Traffic and IntraLATA Toll Traffic is transported on a separate single one-way trunk group terminating to <<customer\_short\_name>>. Other trunk groups for operator services, directory assistance, and intercept may be established pursuant to the applicable BellSouth tariff if service is requested. The LERG contains current routing and tandem serving arrangements. The one-way trunk group architecture is illustrated in Exhibit C.

#### 4.9.1.3 **Two-Way Trunk Group Architecture**

The Two-Way Trunk Group Architecture establishes one two-way trunk group to provide Intratandem Access for the exchange of Local Traffic, ISP-bound Traffic and IntraLATA Toll Traffic between <<customer\_short\_name>> and BellSouth. In addition, a separate two-way transit trunk group must be established for <<customer\_short\_name>>'s originating and terminating Transit Traffic. This trunk group carries Transit Traffic between <<customer\_short\_name>> and Independent Companies, Interexchange Carriers, other CLECs, CMRS providers that have a Meet Point Billing arrangement with BellSouth, and other network providers with which <<customer\_short\_name>> desires to exchange traffic. This trunk group also carries <<customer\_short\_name>> originated Transit Traffic transiting a single BellSouth access tandem destined to third party tandems such as an Independent Company tandem or other CLEC tandem. Either Party's originated traffic, may, in order to prevent or remedy a traffic blocking situations, be transported on a separate single one-way trunk group terminating to the other Party. However, where <<customer\_short\_name>> is responsive in a timely manner to BellSouth's transport needs for its originated traffic, BellSouth originating traffic will be placed on the two-way Local Traffic trunk group carrying ISP-bound Traffic and IntraLATA Toll Traffic. -Other trunk groups for operator services, directory assistance, and intercept may be established pursuant to the applicable BellSouth tariff if service is requested. The LERG contains current routing and tandem serving arrangements. The two-way trunk group architecture is illustrated in Exhibit D.

#### 4.9.1.4 **Supergroup Architecture**

In the Supergroup Architecture, the Parties' Local Traffic, ISP-bound Traffic and IntraLATA Toll Traffic and <<customer\_short\_name>>'s Transit Traffic are

exchanged on a single two-way trunk group between <<customer\_short\_name>> and BellSouth to provide Intratandem Access to <<customer\_short\_name>>. This trunk group carries Transit Traffic between <<customer\_short\_name>> and Independent Companies, Interexchange Carriers, other CLECs, CMRS providers that have a Meet Point Billing arrangement with BellSouth, and other network providers with which <<customer\_short\_name>> desires to exchange traffic. This trunk group also carries <<customer\_short\_name>> originated Transit Traffic transiting a single BellSouth access tandem destined to third party tandems such as an Independent Company tandem or other CLEC tandem. Either Party's originated traffic, may, in order to prevent or remedy a traffic blocking situations, be transported on a separate single one-way trunk group terminating to the other Party. However, where <<customer\_short\_name>> is responsive in a timely manner to BellSouth's transport needs for its originated traffic, BellSouth originating traffic will be placed on the Supergroup. Other trunk groups for operator services, directory assistance, and intercept may be established pursuant to the applicable BellSouth tariff if service is requested. The LERG shall be referenced for current routing and tandem serving arrangements. The Supergroup architecture is illustrated in Exhibit E.

#### 4.9.1.5 **Multiple Tandem Access Interconnection**

4.9.1.5.1 BellSouth Multiple Tandem Access ("MTA") provides for LATA wide BellSouth transport and termination of <<customer\_short\_name>>'s-originated Local Traffic and ISP-bound Traffic transported by BellSouth by establishing an interconnection trunk group at a BellSouth access tandem with routing through multiple BellSouth access tandems as required. <<customer\_short\_name>> must also establish an interconnection trunk group(s) at all BellSouth access tandems where <<customer\_short\_name>> NXXs are homed as described in Section 4.2.1 above. If <<customer\_short\_name>> does not have NXXs homed at any particular BellSouth access tandem within a LATA and elects not to establish an interconnection trunk group(s) at such BellSouth access tandem, <<customer\_short\_name>> can order MTA in each BellSouth access tandem within the LATA where it does have an interconnection trunk group(s) and BellSouth will terminate <<customer\_short\_name>>'s Local Traffic, ISP-bound Traffic and IntraLATA Toll Traffic to End-Users served through those BellSouth access tandems where <<customer\_short\_name>> does not have an interconnection trunk group(s).

4.9.1.5.2 <<customer\_short\_name>> may also utilize MTA to route its originated Transit Traffic; provided, however, that MTA may not be utilized to route switched access traffic that transits the BellSouth network to an Interexchange Carrier (IXC). Switched access traffic originated by or terminated to <<customer\_short\_name>> will be delivered to and from IXCs based on <<customer\_short\_name>>'s NXX access tandem homing arrangement as specified by <<customer\_short\_name>> in the LERG.

4.9.1.5.3 Compensation for MTA shall be at the applicable tandem switching and transport charges specified in Exhibit A to this Attachment and shall be billed in addition to any other applicable Call Transport and Termination charges. The Multiple Tandem Access rate element set forth in Exhibit A applies to the initial tandem only.

4.9.1.5.4 To the extent <<customer\_short\_name>> does not purchase MTA in a LATA served by multiple access tandems, <<customer\_short\_name>> must establish an interconnection trunk group(s) to every access tandem in the LATA to serve the entire LATA. To the extent <<customer\_short\_name>> routes its traffic in such a way that utilizes BellSouth's MTA service without properly ordering MTA, <<customer\_short\_name>> shall pay BellSouth the associated MTA charges. In a situation of tandem exhaust at any particular tandem, where the Parties choose MTA as an alternative routing plan, the Parties will negotiate appropriate rates, terms and conditions for MTA.

#### 4.9.2 **Local Tandem Interconnection**

4.9.2.1 Local Tandem Interconnection arrangement allows <<customer\_short\_name>> to establish an interconnection trunk group(s) at BellSouth local tandems for: (1) the delivery of <<customer\_short\_name>>-originated Local Traffic, ISP-bound Traffic and IntraLATA Toll Traffic transported and terminated by BellSouth to BellSouth end offices served by those BellSouth local tandems, and (2) for local Transit Traffic transported by BellSouth for third party network providers who have also established an interconnection trunk group(s) at those BellSouth local tandems.

4.9.2.2 When a specified local calling area is served by more than one BellSouth local tandem, <<customer\_short\_name>> must designate a "home" local tandem for each of its assigned NPA/NXXs and establish trunk connections to such local tandems. Additionally, <<customer\_short\_name>> may choose to establish an interconnection trunk group(s) at the BellSouth local tandems where it has no codes homing but is not required to do so. <<customer\_short\_name>> may deliver Local Traffic, ISP-bound Traffic and IntraLATA Toll Traffic to a "home" BellSouth local tandem that is destined for other BellSouth or third party network provider end offices subtending other BellSouth local tandems in the same local calling area where <<customer\_short\_name>> does not choose to establish an interconnection trunk group(s). It is <<customer\_short\_name>>'s responsibility to enter its own NPA/NXX local tandem homing arrangements into the LERG either directly or via a vendor in order for other third party network providers to determine appropriate traffic routing to <<customer\_short\_name>>'s codes. Likewise, <<customer\_short\_name>> shall obtain its routing information from the LERG.

4.9.2.3 Notwithstanding establishing an interconnection trunk group(s) to BellSouth's local tandems, <<customer\_short\_name>> must also establish an interconnection

trunk group(s) to BellSouth access tandems within the LATA on which <<customer\_short\_name>> has NPA/NXXs homed for the delivery of Interexchange Carrier Switched Access (SWA) and toll and traffic to Type 2A CMRS connections located at the access tandems. BellSouth shall not switch SWA traffic through more than one BellSouth access tandem. SWA, Type 2A CMRS or toll traffic routed to the local tandem in error will not be backhauled to the BellSouth access tandem for completion. A Type 2A CMRS interconnection is a connection between a BellSouth access tandem or local tandem office to an Mobile Service Provider's point of termination.

#### 4.9.3 **Direct End Office-to-End Office Interconnection**

4.9.3.1 Direct End Office-to-End Office one-way or two-way interconnection trunk groups allow for the delivery of a Party's originating Local Traffic, ISP-bound Traffic and IntraLATA Toll Traffic to the terminating Party on a direct end office-to-end office basis.

4.9.3.2 To the extent technically feasible and where appropriate, BellSouth will provide overflow routing consistent with how BellSouth overflows its traffic. The overflow will be based on the homing arrangements displayed in the LERG.

4.9.3.3 The Parties may utilize direct end office-to-end office trunk groups under any one of the following conditions:

4.9.3.3.1 Tandem Exhaust - If a tandem through which the Parties are interconnected is unable to, or is forecasted to be unable to support additional traffic loads for the Parties or any other carrier for any period of time, the Parties will attempt to mutually agree on an end office trunking plan or an appropriate alternative routing plan that will alleviate the tandem capacity shortage and ensure completion of traffic between <<customer\_short\_name>> and BellSouth.

4.9.3.4 Mutual Agreement - The Parties may install and maintain direct end office trunking upon mutual agreement in the absence of conditions (1) or (2) above.

#### 4.9.4 **Transit Traffic Trunk Group**

Transit Traffic trunks can either be two-way trunks or two one-way trunks ordered by <<customer\_short\_name>> to deliver and receive Transit Traffic. Establishing Transit Traffic trunks at BellSouth access and local tandems provides intratandem access to the third parties also interconnected at those tandems.

#### 4.9.5 **Toll Free Traffic**

4.9.5.1 If <<customer\_short\_name>> chooses BellSouth to perform the Service Switching Point (SSP) Function (i.e., handle Toll Free database queries) from BellSouth's switches, all <<customer\_short\_name>> originating Toll Free traffic will be routed over the Transit Traffic Trunk Group and shall be delivered using

GR-394 format. Carrier Code "0110" and Circuit Code (to be determined for each LATA) shall be used for all such calls.

- 4.9.5.2 <<customer\_short\_name>> may choose to perform its own Toll Free database queries from its switch. In such cases, <<customer\_short\_name>> will determine the nature (local/intraLATA/interLATA) of the Toll Free call (local/IntraLATA/InterLATA) based on the response from the database. If the response from the database determines that the call is a BellSouth local or intraLATA Toll Free call, <<customer\_short\_name>> will route the post-query local or IntraLATA converted ten-digit local number to BellSouth over the local or intraLATA trunk group. If the response from the database determines that the is a third party (ICO, IXC, CMRS or other CLEC) local or intraLATA Toll Free call, <<customer\_short\_name>> will route the post-query local or intraLATA converted ten-digit local number to BellSouth over the Transit Traffic Trunk Group and <<customer\_short\_name>> shall provide to BellSouth a Toll Free billing record when appropriate. If the query reveals the call is an interLATA Toll Free call, <<customer\_short\_name>> will route the post-query interLATA Toll Free call (1) directly from its switch for carriers interconnected with its network or (2) over the Transit Traffic Trunk Group to carriers that are not directly connected to <<customer\_short\_name>>'s network but that are connected to BellSouth's access tandem.
- 4.9.5.3 All post-query Toll Free calls for which <<customer\_short\_name>> performs the SSP function, if delivered to BellSouth, shall be delivered using GR-394 format for calls destined to IXCs, and GR-317 format for calls destined to end offices that directly subtend a BellSouth access tandem within the LATA.

## **5. NETWORK DESIGN AND MANAGEMENT FOR INTERCONNECTION**

- 5.1** Network Management and Changes. Both Parties will work cooperatively with each other to install and maintain the most effective and reliable interconnected telecommunications networks, including but not limited to, the exchange of toll-free maintenance contact numbers and escalation procedures. Both Parties agree to provide public notice of changes in the information necessary for the transmission and routing of services using their local exchange facilities or networks, as well as of any other changes that would affect the interoperability of those facilities and networks, to the extent required by, and in accordance with, applicable federal and state rules and regulations and as otherwise provided in this Agreement.
- 5.2** Interconnection Technical Standards. The interconnection of all networks will be based upon accepted industry/national guidelines for transmission standards and traffic blocking criteria. Interconnecting facilities shall conform, at a minimum, to the telecommunications industry standard of DS-1 pursuant to Telcordia Standard No. TR-NWT-00499. Where <<customer\_short\_name>> chooses to



utilize Signaling System 7 signaling, also known as Common Channel Signaling (SS7), SS7 connectivity is required between the <<customer\_short\_name>> switch and the BellSouth Signaling Transfer Point (STP). BellSouth will provide SS7 signaling using Common Channel Signaling Access Capability in accordance with the technical specifications set forth in the BellSouth Guidelines to Technical Publication, TR-TSV-000905. Facilities of each Party shall provide the necessary on-hook, off-hook answer and disconnect supervision and shall provide calling number ID (Calling Party Number) when technically feasible.

**5.3** Quality of Interconnection. The local interconnection for the transmission and routing of telephone exchange service and exchange access that each Party provides to each other will be at least Equal in Quality to what it provides to itself and any subsidiary or affiliate, where technically feasible, or to any other Party to which each Party provides local interconnection “Equal in Quality” shall have the meaning accorded in Section 51.305(a)(3) of the FCC’s Rules, 47 C.F.R. § 51.305(a)(3).

**5.4** Network Management Controls. Both Parties will work cooperatively to apply sound network management principles by invoking appropriate network management controls (e.g., call gapping) to alleviate or prevent network congestion.

## **6 Signaling**

6.1 BellSouth shall offer access to signaling and access to BellSouth’s signaling databases subject to compatibility testing and at the rates set forth in this Attachment. BellSouth may provide mediated access to BellSouth signaling systems and databases. Available signaling elements include signaling links, signal transfer points and service control points. Signaling functionality will be available with both A-link and B-link connectivity.

6.2 Signaling Link Transport

6.2.1 Signaling Link Transport is a set of two (2) or four (4) dedicated 56 kbps transmission paths between <<customer\_short\_name>> designated Signaling Points of Interconnection that provide appropriate physical diversity.

6.2.2 Technical Requirements

6.2.3 Signaling Link Transport shall consist of full duplex mode 56 kbps transmission paths and shall perform in the following two ways:

6.2.3.1 An “A-link” Signaling Link Transport is a connection between a switch or SCP and a Signaling Transfer Point switch pair; and

- 6.2.3.2 As a “B-link” Signaling Link Transport is a connection between two Signaling Transfer Point switch pairs in different company networks (e.g., between two Signaling Transfer Point switch pairs for two CLECs).
- 6.2.4 Signaling Link Transport shall consist of signaling link layers as follows:
  - 6.2.4.1 An A-link layer shall consist of two (2) links. There shall be no more than two (2) minutes down time per year for an A-link layer.
  - 6.2.4.2 A B-link layer shall consist of four (4) links. There shall be negligible (less than two (2) seconds) down time per year for a B-link layer.
- 6.2.5 A signaling link layer shall satisfy interoffice and intraoffice diversity of facilities and equipment, such that:
  - 6.2.5.1 No single failure of facilities or equipment causes the failure of both links in an A-link layer (i.e., the links should be provided on a minimum of two (2) separate physical paths end-to-end); and
  - 6.2.5.2 No two (2) concurrent failures of facilities or equipment shall cause the failure of all four (4) links in a B-link layer (i.e., the links should be provided on a minimum of three (3) separate physical paths end-to-end).
- 6.2.6 Interface Requirements
  - 6.2.6.1 There shall be a DS1 (1.544 Mbps) interface at <<customer\_short\_name>>’s designated SPOIs. Each 56 kbps transmission path shall appear as a DS0 channel within the DS1 interface.
- 6.3 Signaling Transfer Points (STPs)
  - 6.3.1 A Signaling Transfer Point is a signaling network function that includes all of the capabilities provided by the signaling transfer point switches (STPs) and their associated signaling links that enables the exchange of SS7 messages among and between switching elements, database elements and STPs.
  - 6.3.2 Technical Requirements
    - 6.3.2.1 STPs shall provide access to BellSouth Local Switching or Tandem Switching and to BellSouth Service Control Points/Databases connected to BellSouth SS7 network. STPs also provide access to third-party local or tandem switching and third-party-provided STPs.
    - 6.3.2.2 The connectivity provided by STPs shall fully support the functions of all other Network Elements connected to the BellSouth SS7 network. This includes the

use of the BellSouth SS7 network to convey messages that neither originate nor terminate at a signaling end point directly connected to the BellSouth SS7 network (i.e., transit messages). When the BellSouth SS7 network is used to convey transit messages, there shall be no alteration of the Integrated Services Digital Network User Part or Transaction Capabilities Application Part (TCAP) user data that constitutes the content of the message.

- 6.3.2.3 STPs shall provide all functions of the SCCP necessary for Class 0 (basic connectionless) service, as defined in Telcordia ANSI Interconnection Requirements. This includes Global Title Translation (GTT) and SCCP Management procedures, as specified in ANSI T1.112.4. Where the destination signaling point is a <<customer\_short\_name>> or third party local or tandem switching system directly connected to BellSouth SS7 network, BellSouth shall perform final GTT of messages to the destination and SCCP Subsystem Management of the destination. In all other cases, BellSouth shall perform intermediate GTT of messages to a gateway pair of STPs in an SS7 network connected with the BellSouth SS7 network, and shall not perform SCCP Subsystem Management of the destination. If BellSouth performs final GTT to a <<customer\_short\_name>> database, then <<customer\_short\_name>> agrees to provide BellSouth with the Destination Point Code for <<customer\_short\_name>> database.
- 6.3.2.4 STPs shall provide all functions of the Operations, Maintenance and Administration Part (OMAP) as specified in applicable industry standard technical references, which may include, where available in BellSouth's network, MTP Routing Verification Test (MRVT); and SCCP Routing Verification Test (SRVT).
- 6.3.2.5 Where the destination signaling point is a BellSouth local or tandem switching system or database, or is a <<customer\_short\_name>> or third party local or tandem switching system directly connected to the BellSouth SS7 network, STPs shall perform MRVT and SRVT to the destination signaling point. In all other cases, STPs shall perform MRVT and SRVT to a gateway pair of STPs in an SS7 network connected with the BellSouth SS7 network. This requirement may be superseded by the specifications for Internetwork MRVT and SRVT when these become approved ANSI standards and available capabilities of BellSouth STPs.
- 6.4 SS7 Advanced Intelligent Network (AIN) Access
- 6.4.1 Interface Requirements
- 6.4.1.1 BellSouth shall provide the following STP options to connect <<customer\_short\_name>> or <<customer\_short\_name>>-designated local switching systems to the BellSouth SS7 network:

- 6.4.1.1.1 An A-link interface from <<customer\_short\_name>> local switching systems;  
and,
- 6.4.1.1.2 A B-link interface from <<customer\_short\_name>> local STPs.
- 6.4.1.2 Each type of interface shall be provided by one or more layers of signaling links.
- 6.4.1.3 The Signaling Point of Interconnection for each link shall be located at a cross connect element in the central office where the BellSouth STP is located.
- 6.4.1.4 BellSouth shall provide intraoffice diversity between the SPOI and BellSouth STPs, so that no single failure of intraoffice facilities or equipment shall cause the failure of both B-links in a layer connecting to a BellSouth STP.
- 6.4.1.5 STPs shall provide all functions of the MTP as defined in the applicable industry standard technical references.
- 6.4.2 Message Screening
  - 6.4.2.1 BellSouth shall set message screening parameters so as to accept/send valid messages from <<customer\_short\_name>> local or tandem switching systems destined to/from any signaling point within BellSouth's SS7 network where the <<customer\_short\_name>> switching system has a valid signaling relationship.
  - 6.4.3 BellSouth shall set message screening parameters so as to accept/send valid messages from <<customer\_short\_name>> local or tandem switching systems destined to/from any signalling point or network accessed through BellSouth's SS7 network where the <<customer\_short\_name>> switching system has a valid signalling relationship.
- 6.5 Service Control Points/Databases
  - 6.5.1 Call Related Databases provide the storage of, access to, and manipulation of information required to offer a particular service and/or capability. BellSouth shall provide access to the following Databases: Local Number Portability, LIDB, Toll Free Number Database, Automatic Location Identification/Data Management System, and Calling Name Database. BellSouth also provides access to Service Creation Environment and Service Management System (SCE/SMS) application databases and Directory Assistance.
  - 6.5.2 A Service Control Point (SCP) is deployed in a SS7 network that executes service application logic in response to SS7 queries sent to it by a switching system also connected to the SS7 network. Service Management Systems provide operational interfaces to allow for provisioning, administration and maintenance of subscriber data and service application data stored in SCPs.

- 6.5.3 Technical Requirements for SCPs/Databases
  - 6.5.3.1 BellSouth shall provide physical access to SCPs through the SS7 network and protocols with TCAP as the application layer protocol.
  - 6.5.3.2 BellSouth shall provide physical interconnection to databases via industry standard interfaces and protocols (e.g. SS7, ISDN and X.25).
  - 6.5.3.3 The reliability of interconnection options shall be consistent with requirements for diversity and survivability.
- 6.6 Local Number Portability Database
  - 6.6.1 The Permanent Number Portability (PNP) database supplies routing numbers for calls involving numbers that have been ported from one local service provider to another. BellSouth agrees to provide access to the PNP database at rates, terms and conditions as set forth by BellSouth and in accordance with an effective FCC or Commission directive.
- 6.7 SS7 Network Interconnection
  - 6.7.1 SS7 Network Interconnection is the interconnection of <<customer\_short\_name>> local STPs or <<customer\_short\_name>> local or tandem switching systems with BellSouth STPs. This interconnection provides connectivity that enables the exchange of SS7 messages among BellSouth switching systems and databases, <<customer\_short\_name>> local or tandem switching systems, and other third-party switching systems directly connected to the BellSouth SS7 network.
  - 6.7.2 The connectivity provided by SS7 Network Interconnection shall fully support the functions of BellSouth switching systems and databases and <<customer\_short\_name>> or other third-party switching systems with A-link access to the BellSouth SS7 network.
  - 6.7.3 If traffic is routed based on dialed or translated digits between a <<customer\_short\_name>> local switching system and a BellSouth or other third-party local switching system, either directly or via a BellSouth tandem switching system, then it is a requirement that the BellSouth SS7 network convey via SS7 Network Interconnection the TCAP messages that are necessary to provide Call Management services (Automatic Callback, Automatic Recall, and Screening List Editing) between the <<customer\_short\_name>> local STPs and BellSouth or other third-party local switch.
  - 6.7.4 SS7 Network Interconnection shall provide:

- 6.7.4.1 Signaling Data Link functions, as specified in ANSI T1.111.2;
- 6.7.4.2 Signaling Link functions, as specified in ANSI T1.111.3; and
- 6.7.4.3 Signaling Network Management functions, as specified in ANSI T1.111.4.
- 6.7.5 SS7 Network Interconnection shall provide all functions of the SCCP necessary for Class 0 (basic connectionless) service, as specified in ANSI T1.112. This includes GTT and SCCP Management procedures, as specified in ANSI T1.112.4. Where the destination signaling point is a BellSouth switching system or database, or is another third-party local or tandem switching system directly connected to the BellSouth SS7 network, SS7 Network Interconnection shall include final GTT of messages to the destination and SCCP Subsystem Management of the destination. Where the destination signaling point is a <<customer\_short\_name>> local or tandem switching system, SS7 Network Interconnection shall include intermediate GTT of messages to a gateway pair of <<customer\_short\_name>> local STPs, and shall not include SCCP Subsystem Management of the destination.
- 6.7.6 SS7 Network Interconnection shall provide all functions of the Integrated Services Digital Network User Part, as specified in ANSI T1.113.
- 6.7.7 SS7 Network Interconnection shall provide all functions of the TCAP, as specified in ANSI T1.114.
- 6.7.8 If Internetwork MRVT and SRVT become approved ANSI standards and available capabilities of BellSouth STPs, SS7 Network Interconnection may provide these functions of the OMAP.
- 6.7.9 Interface Requirements
  - 6.7.9.1 The following SS7 Network Interconnection interface options are available to connect <<customer\_short\_name>> or <<customer\_short\_name>>-designated local or tandem switching systems or STPs to the BellSouth SS7 network:
    - 6.7.9.1.1 A-link interface from <<customer\_short\_name>> local or tandem switching systems; and
    - 6.7.9.1.2 B-link interface from <<customer\_short\_name>> STPs.
  - 6.7.9.2 The SPOI for each link shall be located at a cross-connect element in the central office where the BellSouth STP is located. There shall be a DS1 or higher rate transport interface at each of the SPOIs. Each signaling link shall appear as a DS0 channel within the DS1 or higher rate interface.

- 6.7.9.3 BellSouth shall provide intraoffice diversity between the SPOIs and the BellSouth STP, so that no single failure of intraoffice facilities or equipment shall cause the failure of both B-links in a layer connecting to a BellSouth STP.
- 6.7.9.4 The protocol interface requirements for SS7 Network Interconnection include the MTP, ISDNUP, SCCP, and TCAP. These protocol interfaces shall conform to the applicable industry standard technical references. BellSouth does not have the capability to support any of the VoIP interfaces at the present time but is willing to negotiate new protocol interfaces.
- 6.7.9.5 BellSouth shall set message screening parameters to accept messages from <<customer\_short\_name>> local or tandem switching systems destined to any signaling point in the BellSouth SS7 network with which the <<customer\_short\_name>> switching system has a valid signaling relationship.
- 6.8 Rate Categories And Applications
- 6.8.1 Message Charges
- 6.8.1.1 Message charges, as set forth in 6.8.1.3, following, are assessed based on the type of message protocol, ISUP or TCAP. ISUP messages are associated with call set-up, while TCAP messages are used to query call related databases. ISUP message charges are assessed per terminating and originating call set-up request and TCAP message charges are assessed per data request.
- 6.8.1.2 Message charges do not apply for TCAP messages switched by the regional STPs to the BellSouth provided 800 Data Base, LIDB or LNP Data Base. Query charges are assessed in lieu of message charges. Query charges for 800 Data Base are described in 6.9.5, following. When TCAP messages are destined for a foreign database, including a non-company provided LNP Data Base, message charges are assessed in lieu of query charges.
- 6.8.1.3 Message charges are assessed in the following manner:
- 6.8.1.3.1 Signal Formulation
- 6.8.1.3.1.1 An ISUP Signal Formulation charge is assessed, per call set-up request, for terminating and originating formulating signaling messages in association with call set-up.
- 6.8.1.3.2 Signal Transport
- 6.8.1.3.2.1 An ISUP Signal Transport charge is assessed, per call set-up request, for signaling messages transported to and from the Company STP in association with call set-up.

- 6.8.1.3.2.2 A TCAP Signal Transport charge is assessed per data request transported to a BellSouth STP and destined for a foreign database.
- 6.8.1.3.3 Signal Switching
- 6.8.1.3.3.1 An ISUP Signal Switching charge is assessed per call set-up request that is switched at the Company STP for terminating and originating messages .
- 6.8.1.3.3.2 A TCAP Signal Switching charge is assessed for each data request that is switched by the Company STP and destined for a foreign network or database.
- 6.8.1.3.4 Query Charges
- 6.8.1.3.4.1 Query charges apply for queries to the Company LIDB and the LNP Data Base. When query charges apply for access to a Company provided database, message charges are not assessed. LIDB Query Charges are described in 6.9.3, following and the LNP Data Base Query Charge is described in 6.9.4, following.
- 6.8.1.4 TCAP Bill and Keep
- 6.8.1.4.1 The Parties agree to treat signaling messages, signaling ports, and signaling links associated with local calls on a bill and keep basis.
- 6.8.1.4.2 <<customer\_short\_name>> and BellSouth agree that BellSouth will bill <<customer\_short\_name>> for signaling links, signaling ports, and signaling messages associated with interstate calls and with intrastate non-local calls in accordance with BellSouth's federal and state tariffs.
- 6.8.1.4.3 Beginning on the Effective Date of this Agreement and continuing until <<customer\_short\_name>> implements a system that is capable of counting the total number of signaling messages that traveled over facilities connecting <<customer\_short\_name>>'s CCS7 network and BellSouth's CCS7 network, BellSouth agrees that for the purposes of billing BellSouth for signaling messages for any given month, <<customer\_short\_name>> may use the total number of signaling messages that BellSouth's signaling bill to <<customer\_short\_name>> indicates have traveled over facilities connecting <<customer\_short\_name>>'s CCS7 network and BellSouth's CCS7 network for that same month. When <<customer\_short\_name>> implements a system that is capable of counting the total number of signaling messages that travel over facilities connecting <<customer\_short\_name>>'s CCS7 network and BellSouth's CCS7 network, <<customer\_short\_name>> will use the number of signaling messages counted by such system for the purposes of billing BellSouth for signaling messages, subject to BellSouth's right to contest the accuracy of the number of signaling messages counted by such system.



6.8.1.4.4 For the purposes of billing BellSouth for signaling messages, <<customer\_short\_name>> will apply the SPIU/SPLU provided by BellSouth (which can, at BellSouth's option, be the same as the PIU/PLU that BellSouth provides for minutes of use) to the number of messages calculated pursuant to Paragraph 6.8.1.4.3 above.

6.9 RATES AND CHARGES ASSOCIATED WITH SS7

6.9.1	Message Charge for ISUP Messages	RATE
	Per signaling message	Bill & Keep

6.9.2	Message Charge for TCAP Messages	RATE
	Per signaling message	Bill & Keep

6.9.3 LINE INFORMATION DATA BASE SERVICE

RATE PER QUERY

Per Access Transport Query	Exhibit A of Attachment 2 for UNE-P Only, Tariff Rate for All Others
Per Validation Service Query	Exhibit A of Attachment 2 for UNE-P Only, Tariff Rate for All Others
Per OLNS Service Query	Tariff Rate

6.9.4 LOCAL NUMBER PORTABILITY DATA BASE SERVICE

Per LNP Query	Exhibit A of Attachment 2 for UNE-P Only
Negotiated Rates Pursuant to a Separate Agreement for All Others	

6.9.5 800 DATA BASE SERVICE

Per 800 Query	Exhibit A of Attachment 2 for UNE-P Only, Tariff Rate for All Others
---------------	--

**7. FORECASTING FOR TRUNK PROVISIONING**

- 7.1** Within six (6) months after execution of this Agreement, <<customer\_short\_name>> shall provide an initial interconnection trunk group forecast for each LATA in which it plans to provide service within BellSouth's region. BellSouth's reciprocal trunking forecasts will be based upon information provided by <<customer\_short\_name>> in the initial forecast. If <<customer\_short\_name>> refuses to provide such information, BellSouth shall provide reciprocal trunking forecasts based only on existing trunk group growth and BellSouth's annual estimated percentage of BellSouth subscriber line growth. After the exchange of each Party's forecast information, the Parties shall conduct a joint planning meeting to develop a joint interconnection trunk group forecast. Each forecast provided under this Section shall be deemed "Confidential Information" under the General Terms and Conditions of this Agreement.
- 7.2** The Parties shall use best efforts to make the initial and semi-annual subsequent forecasts as accurate as possible based on reasonable engineering criteria. In addition, the Parties agree to proactively manage their interconnection trunking arrangements and use best efforts to timely notify each other if forecasted need quantities change or if a known or anticipated network event that may create a blocking situation is likely to occur during the time period between joint planning meetings. Joint planning meetings shall be conducted via conference call, unless mutual agreement is reached otherwise.
- 7.3** At a minimum, the joint forecast shall include the projected quantity of Transit Trunks, <<customer\_short\_name>>-to-BellSouth one-way trunks (<<customer\_short\_name>> Trunks), BellSouth-to-<<customer\_short\_name>> one-way trunks (Reciprocal Trunks) and/or two-way interconnection trunks, if the Parties have agreed to interconnect using two-way trunking to transport the Parties' Local Traffic, ISP-Bound Traffic and IntraLATA Toll Traffic. The quantities shall be projected for a minimum of six months and shall include an estimate of the current year plus the next two years total forecasted quantities. The Parties shall mutually develop Reciprocal Trunk Groups and/or two-way interconnection trunk forecast quantities.
- 7.4** All forecasts shall include, at a minimum, Access Carrier Terminal Location (ACTL), trunk group type (local/intraLATA toll, Transit, Operator Services, 911, etc.), A location/Z location (CLLI codes for <<customer\_short\_name>> location and BellSouth location where the trunks shall terminate), interface type (e.g., DS1), Direction of Signaling, Trunk Group Number, if known, (commonly referred to as the 2-6 code) and forecasted trunks in service each year (cumulative).
- 7.5** The submitting and development of interconnection trunk forecasts shall not replace the ordering process for local interconnection trunks. Each Party shall exercise its best efforts and act in good faith to plan for and provide the quantity of interconnection trunks mutually forecasted. However, the provision of the forecasted quantity of interconnection trunks is subject to trunk terminations and

facility capacity existing at the time the trunk order is submitted and BellSouth shall not be responsible for a lack of interconnection trunks provided that best efforts and good faith have been exercised.

## **8. TRUNK UTILIZATION**

**8.1** For the Reciprocal Trunk Groups that cannot overflow traffic to another trunk group (Reciprocal Final Trunk Groups), BellSouth and <<customer\_short\_name>> shall monitor traffic on each interconnection Reciprocal Final Trunk Group that is ordered and installed. The Parties agree that the Reciprocal Final Trunk Groups will be utilized at 60 percent (60%) of the time consistent busy hour utilization level within 180 days of installation. The Parties agree that the Reciprocal Final Trunk Groups will be utilized at eighty percent (80%) of the time consistent busy hour utilization level within 365 days of installation. Any Reciprocal Final Trunk Group not meeting the minimum thresholds set forth in this Section are defined as "Under-utilized" trunks. BellSouth may disconnect any Under-utilized Reciprocal Final Trunk Groups and, for trunks not in excess of <<customer\_short\_name>>'s forecast, <<customer\_short\_name>> shall refund to BellSouth the associated nonrecurring and recurring trunk and facility charges paid by BellSouth, if any.

**8.1.1** BellSouth's CISC will notify <<customer\_short\_name>> of any under-utilized Reciprocal Trunk Groups and the number of such trunk groups that BellSouth wishes to disconnect. BellSouth will provide supporting information either by email or facsimile to the designated <<customer\_short\_name>> interface. <<customer\_short\_name>> will provide concurrence with the disconnection in seven (7) business days or will provide specific information supporting why the trunks should not be disconnected. Such supporting information should include expected traffic volumes (including traffic volumes generated due to Local Number Portability) and the timeframes within which <<customer\_short\_name>> expects to need such trunks. BellSouth's CISC Project Manager and Circuit Capacity Manager will discuss the information with <<customer\_short\_name>> to determine if agreement can be reached on the number of Reciprocal Final Trunk Groups to be removed. If no agreement can be reached, BellSouth will issue disconnect orders to <<customer\_short\_name>>. Notwithstanding any other provision to this Agreement, the Parties will disconnect the underutilized trunks no sooner than two weeks after <<customer\_short\_name>> receives such disconnect orders, unless the parties mutually agree to do so sooner.

**8.1.2** To the extent that any interconnection trunk group is utilized at a time-consistent busy hour of eighty percent (80%) or greater, the Parties may review the trunk groups and, if necessary, shall negotiate in good faith for the installation of augmented facilities.

**8.2** For the two-way trunk groups that cannot overflow traffic to another trunk group and other than alternate final trunk groups, BellSouth and

<<customer\_short\_name>> shall monitor traffic on each interconnection trunk group that is ordered and installed. The Parties agree that within 180 days of the installation of the BellSouth two-way trunk or trunks, the trunks will be utilized at 60 percent (60%) of the time consistent busy hour utilization level. The Parties agree that within 365 days of the installation of a trunk or trunks, the trunks will be utilized at eighty percent (80%) of the time consistent busy hour utilization level. Any trunk or trunks not meeting the minimum thresholds set forth in this Section are defined as "Under-utilized" trunks. BellSouth will request the disconnection of any Under-utilized two-way trunk(s) and, for trunks not in excess of <<customer\_short\_name>>'s forecast, <<customer\_short\_name>> shall refund to BellSouth the associated nonrecurring and recurring trunk and facility charges paid by BellSouth, if any.

8.2.1 BellSouth's LISC will notify <<customer\_short\_name>> of any under-utilized two-way trunk groups and the number of trunks that BellSouth wishes to disconnect. BellSouth will provide supporting information either by email or facsimile to the designated <<customer\_short\_name>> interface. <<customer\_short\_name>> will provide concurrence with the disconnection in seven (7) business days or will provide specific information supporting why the two-way trunks should not be disconnected. Such supporting information should include expected traffic volumes (including traffic volumes generated due to Local Number Portability) and the timeframes within which <<customer\_short\_name>> expects to need such trunks. BellSouth's CISC Project Manager and Circuit Capacity Manager will discuss the information with <<customer\_short\_name>> to determine if agreement can be reached on the number of trunks to be removed. If no agreement can be reached, <<customer\_short\_name>> will issue disconnect orders to BellSouth. Notwithstanding any other provision to this Agreement, the Parties will disconnect the underutilized trunks no sooner than two weeks after <<customer\_short\_name>> receives such disconnect orders, unless the parties mutually agree to do so sooner.

8.2.2 To the extent that any interconnection trunk group is utilized at a time-consistent busy hour of eighty percent (80%) or greater, the Parties shall review the trunk groups and, if necessary, shall negotiate in good faith for the installation of augmented facilities.

## **9. INTERFERENCE OR IMPAIRMENT**

9.1 As soon as possible and in no case later than twenty-four (24) hours after receipt of notification of blocking of traffic originated within the other Party's network, the Parties shall determine and begin work to implement reasonable corrective measures in a manner consistent with industry practices.

9.2 In the event of an outage or trouble in any arrangement, facility, or service being provided by BellSouth hereunder, BellSouth will follow procedures for isolating

and clearing the outage or trouble that are no less favorable than those that apply to comparable arrangements, facilities, or services being provided by BellSouth to itself, Affiliate or any other carrier whose network is connected to that of BellSouth.

- 9.3** BellSouth will use best efforts to provide <<customer\_short\_name>> with at least thirty (30) days advance notification of scheduled maintenance activity. Upon such notice, <<customer\_short\_name>> may submit a reasonable request for additional information relevant to the scheduled maintenance activity and BellSouth shall provide such information to the extent the scheduled maintenance activity may impact NewSouth and such information is reasonably necessary for <<customer\_short\_name>> to identify and analyze potential risks associated with such maintenance. BellSouth may expedite or delay scheduled maintenance as a result of unscheduled maintenance or other unforeseen events. In those instances where BellSouth will not perform scheduled maintenance at the announced times, BellSouth will make best efforts to provide <<customer\_short\_name>> with as much notice as is reasonably possible concerning the changed schedule.
- 9.4** For switch software/processor updates, software upgrades/new releases to the SONET transport network elements, or other major scheduled events which might impact <<customer\_short\_name>>, BellSouth shall use best efforts to provide <<customer\_short\_name>> with at least thirty (30) days advance notification of scheduled maintenance activity. Upon such notice, <<customer\_short\_name>> may submit a reasonable request for additional information relevant to the scheduled maintenance activity and BellSouth shall provide such information to the extent the scheduled maintenance activity may impact NewSouth and such information is reasonably necessary for <<customer\_short\_name>> to identify and analyze potential risks associated with such maintenance.
- 9.5** BellSouth will use best efforts to provide <<customer\_short\_name>>'s Network Operations Center with at least thirty (30) days advance, written notice when translations are scheduled to be modified on <<customer\_short\_name>>'s trunk groups.
- 9.6** [Parties Disagree]
- [NewSouth Version] Once <<customer\_short\_name>> determines that there is an outage that encompasses either a particular section of the network or the whole network, then <<customer\_short\_name>> shall generate a trouble ticket to the CISC. After issuing the trouble ticket, <<customer\_short\_name>> will notify the appropriate BellSouth representative in the CISC via telephone. <<customer\_short\_name>> may then send an email confirmation to such BellSouth representative. BellSouth will work cooperatively with <<customer\_short\_name>> to determine the appropriate steps to resolve such outage. Additionally, <<customer\_short\_name>> will provide BellSouth with

any applicable information that is necessary to resolve such outage and the Parties will work cooperatively to take all steps necessary to resolve the outage. **Upon request, BellSouth will provide a written root cause analysis report for all global outages, and for any trunk group outage that has occurred 3 or more times in a 60 day period. BellSouth shall use best efforts to provide such report within five (5) business days after the request for it is made.**

[BellSouth Version] Once <<customer\_short\_name>> determines that there is an outage that encompasses either a particular section of the network or the whole network, then <<customer\_short\_name>> shall generate a trouble ticket to the CISC. After issuing the trouble ticket, <<customer\_short\_name>> will notify the appropriate BellSouth representative in the CISC via telephone. <<customer\_short\_name>> may then send an email confirmation to such BellSouth representative. BellSouth will work cooperatively with <<customer\_short\_name>> to determine the appropriate steps to resolve such outage. Additionally, <<customer\_short\_name>> will provide BellSouth with any applicable information that is necessary to resolve such outage and the Parties will work cooperatively to take all steps necessary to resolve the outage. <<customer\_short\_name>> **may submit a reasonable request to BellSouth for a written analysis of the cause of any global outage affecting <<customer\_short\_name>>'s network. BellSouth shall use best efforts to provide such report within thirty (30) days of such request.**

**10. COMPENSATION FOR CALL TRANSPORT AND TERMINATION FOR LOCAL TRAFFIC AND ISP-BOUND TRAFFIC.**

- 10.1** Neither Party shall pay compensation to the other Party for per minute of use rate elements associated with the Call Transport and Termination of Local Traffic or ISP-bound Traffic.
- 10.2** The appropriate elemental rates set forth in Exhibit A of this Attachment shall apply for Transit Traffic as described in this Attachment and to Multiple Tandem Access as described in this Attachment.
- 10.3** Neither Party shall represent Switched Access Traffic, as defined in this Attachment, as Local Traffic or ISP-bound Traffic for purposes of determining compensation for the call.
- 10.4** If <<customer\_short\_name>> assigns NPA/NXXs to specific BellSouth rate centers within the LATA and assigns numbers from those NPA/NXXs to <<customer\_short\_name>> End Users physically located outside of that LATA, BellSouth originated traffic that is not bound for an Internet Service Provider ("ISP") and originates from within the LATA where the NPA/NXXs are assigned and is delivered to a <<customer\_short\_name>> End User physically located outside of such LATA shall not be deemed Local Traffic. Further, <<customer\_short\_name>> agrees to identify such traffic to BellSouth, to the

extent technically feasible, and to compensate BellSouth for originating and transporting such non-local traffic to <<customer\_short\_name>> at BellSouth's switched access tariff rates.

- 10.4.1 The Parties have been unable to agree on the treatment of calls where <<customer\_short\_name>> assigns NPA/NXXs to specific BellSouth rate centers within the LATA and assigns numbers from those NPA/NXXs to <<customer\_short\_name>> End Users physically located outside of that LATA and such End Users are Internet Service Providers ("ISPs"). Notwithstanding the foregoing, and without waiving any rights with respect to either Party's position as to the treatment of such calls, the Parties agree that, for purposes of this Agreement, traffic delivered to an End User that is an ISP physically located outside of such LATA shall be considered ISP-bound Traffic as defined in this Attachment.

## 10.5 Jurisdictional Reporting

- 10.5.1 **Percent Local Usage.** Each Party shall report to the other a Percent Local Usage (PLU) factor. The application of the PLU will determine the amount of Local/ISP-Bound minutes to be billed to the other Party. Local and ISP-bound Traffic shall be treated as Local for purposes of calculating the PLU. Requirements associated with PLU calculation and reporting shall be as set forth in BellSouth's Jurisdictional Factors Reporting Guide, attached hereto as Exhibit F.
- 10.5.2 **Percent Local Facility.** Each Party shall report to the other a Percent Local Facility (PLF) factor. The application of the PLF will determine the portion of switched dedicated transport to be billed per the local jurisdiction rates. The PLF shall be applied to Multiplexing, Local Channel and Interoffice Channel Switched Dedicated Transport utilized in the provision of local interconnection trunks. Requirements associated with PLF calculation and reporting shall be as set forth in BellSouth's Jurisdictional Factors Reporting Guide, attached hereto as Exhibit F.
- 10.5.3 **Percent Interstate Usage.** Each Party shall report to the other a Percent Interstate Usage (PIU) factor. Requirements associated with PIU calculation and reporting shall be as set forth in BellSouth's Jurisdictional Factors Reporting Guide, attached hereto as Exhibit F.
- 10.5.4 **Application of Factors.** After interstate and intrastate traffic percentages have been determined by use of PIU procedures, the PLU factor will be used for application and billing of Call Transport and Termination consistent with Section 7.1 of this Attachment.
- 10.5.5 **In Lieu of Jurisdictional Factors Reported.** Notwithstanding the provisions in Section 10.5.1, 10.5.2, and 10.5.3 above, where the terminating Party has message

recording technology that identifies the jurisdiction of traffic terminated as defined in this Agreement, such information may, at the terminating Party's option, be utilized to determine the appropriate jurisdictional reporting factors, in lieu of those provided by the originating Party. In the event that the terminating Party opts to utilize its own data to determine jurisdictional reporting factors, such terminating Party shall notify the originating Party at least 30 days prior to the beginning of the calendar quarter in which the terminating Party will begin to utilize its own data.

10.5.5.1 Upon the request of the originating Party, the terminating Party shall provide supporting data for the jurisdictional factors proposed by the terminating Party to be used in lieu of those reported by the originating Party. The originating Party shall have 30 days to consent or object to the proposed replacement of reported factors. If the originating Party consents or fails to respond within 30 days, the terminating Party may proceed with the replacement of factors effective at the beginning of the calendar quarter. If the originating Party objects to the proposed replacement of reported factors, the Parties shall proceed as set forth below.

10.5.5.2 [Parties Disagree]

[NewSouth Version] Upon either Party's request, the Parties will work in good faith to resolve the discrepancy between the factors submitted by the originating party and those proposed by the terminating party pursuant to Section 7.2.5 above. In the event that the Parties are unable to mutually agree as to the appropriate resolution, the Parties may negotiate a mutually agreeable resolution based on the data specific to the traffic patterns of the originating party or either Party may request an audit of the factors in accordance with Section 7.2.9 below. In the event that negotiations and audits fail to resolve disputes between the parties, either Party may seek Dispute Resolution as set forth in the General Terms and Conditions. **While such a dispute is pending, factors reported by the originating Party shall remain in place, unless the Parties mutually agree otherwise.**

[BellSouth Version] Upon either Party's request, the Parties will work in good faith to resolve the discrepancy between the factors submitted by the originating party and those proposed by the terminating party pursuant to Section 7.2.5 above. In the event that the Parties are unable to mutually agree as to the appropriate resolution, the Parties may negotiate a mutually agreeable resolution based on the data specific to the traffic patterns of the originating party or either Party may request an audit of the factors in accordance with Section 7.2.9 below. In the event that negotiations and audits fail to resolve disputes between the parties, either Party may seek Dispute Resolution as set forth in the General Terms and Conditions. **While such a dispute is pending, the factors proposed by the terminating Party pursuant to Section 7.2.5 above shall be utilized, unless the Parties mutually agree otherwise.**



10.5.5.3 Audits. On thirty (30) days written notice, each Party must provide the other the ability and opportunity to conduct an annual audit of the jurisdictional reporting factors as reported or utilized pursuant to this Attachment 3 to ensure the proper billing of traffic. BellSouth and <<customer\_short\_name>> shall retain records of call detail for a minimum of nine months from which the jurisdictional reporting factors can be ascertained. The audit shall be conducted during normal business hours at an office designated by the Party being audited. Audit requests shall not be submitted more frequently than one (1) time per calendar year. The Parties shall use commercially reasonable efforts to complete audits in as timely a manner as possible. Audits shall be performed by a mutually acceptable independent auditor paid for by the Party requesting the audit. The jurisdictional reporting factors shall be adjusted based upon the audit results and shall apply for the quarter the audit was completed, for the quarter prior to the completion of the audit, and for the two quarters following the completion of the audit. If, as a result of an audit, either Party is found to have overstated jurisdictional reporting factors by twenty percentage points (20%) or more, that Party shall reimburse the auditing Party for the cost of the audit

## 10.6 Compensation for 8XX Traffic

10.6.1 Compensation for 8XX Traffic. Each Party shall compensate the other pursuant to the appropriate Switched Access charges, including the database query charge as applicable, as set forth in the providing Party's tariff, as filed and effective with the FCC or Commission, or reasonable and non-discriminatory web-posted listing if the FCC or Commission does not require filing of a tariff.

10.6.2 Records for 8XX Billing. Each Party will provide to the other the appropriate records necessary for billing intraLATA 8XX customers. The records provided will be in a standard EMI format.

10.6.3 8XX Access Toll Free Dialing Ten Digit Screening ("TFD"). BellSouth's provision of TFD to <<customer\_short\_name>> requires interconnection from <<customer\_short\_name>> to BellSouth's 8XX Signal Channel Point (SCP). Such interconnections shall be established pursuant to BellSouth's Common Channel Signaling Interconnection Guidelines and Telcordia's CCS Network Interface Specification document, TR-TSV-000905. <<customer\_short\_name>> shall establish SS7 interconnection at the BellSouth Local Signal Transfer Points serving the BellSouth 8XX SCPs that <<customer\_short\_name>> desires to query. The terms and conditions for 8XX TFD are set out in BellSouth's Intrastate Access Services Tariff.

10.7 Switched Access Traffic is defined as telephone calls requiring local transmission or switching services for the purpose of the origination or termination of Telephone Toll Service. Switched Access Traffic includes the following types of traffic: Feature Group A, Feature Group B, Feature Group C, Feature Group D,

toll free access (e.g., 800/877/888), and 900 access services. Switched Access Traffic does not include Local Traffic and ISP-Bound Traffic originated by one Party and terminated by the other. The Parties have been unable to agree as to whether “Voice-Over-Internet Protocol” transmissions (“VOIP”) which cross LATA boundaries constitute Switched Access Traffic. Notwithstanding the foregoing, and without waiving any rights with respect to either Party’s position as to the jurisdictional nature of VOIP, the Parties agree to amend this Agreement in accordance with the General Terms and Conditions of this Agreement to abide by any effective and applicable FCC rules and orders regarding the nature of such traffic and the compensation payable by the Parties for such traffic, if any.

- 10.7.1 If the BellSouth End User chooses <<customer\_short\_name>> as their presubscribed interexchange carrier, or if the BellSouth End User uses <<customer\_short\_name>> as an interexchange carrier on a 101XXXX basis, BellSouth will charge <<customer\_short\_name>> the appropriate BellSouth tariff charges for originating switched access services.
- 10.7.2 Where the originating Party delivers Switched Access Traffic to the terminating Party, the originating Party will pay the terminating Party terminating switched access charges as set forth in the providing Party’s tariff, as filed and effective with the FCC or Commission, or reasonable and non-discriminatory web-posted listing if the FCC or Commission does not require filing of a tariff.
- 10.7.3 When one Party’s end office switch, subtending the other Party’s Access Tandem switch for receipt or delivery of switched access traffic, provides an access service connection to or from an interexchange carrier (“IXC”) by either a direct trunk group to the IXC utilizing the other Party’s facilities, or via the other Party’s tandem switch, each Party will provide its own access services to the IXC and bill on a multi-bill, multi-tariff meet-point basis. Each Party will bill its own access services rates to the IXC with the exception of the interconnection charge. The interconnection charge will be billed by the Party providing the end office function. The Parties will use the Multiple Exchange Carrier Access Billing (MECAB) guidelines to establish meet point billing for all applicable traffic. . Thirty (30)-day billing periods will be employed for these arrangements. To the extent either party is providing the tandem function, that party (i.e., Initial Billing Company) agrees to provide to the other company (i.e., Subsequent Billing Company), as defined in MECAB, at no charge, the switched access detailed usage data within no more than sixty (60) days after the recording date where technically feasible. Each company will notify the other when it determines that it is not feasible to meet these requirements so that the customers may be notified for any necessary revenue accrual associated with the significantly delayed recording or billing. As business requirements change, data reporting requirements may be modified as necessary, by mutual agreement of the Parties or per a change in industry standards.
- 10.7.4 [Parties Disagree]

**[NewSouth Version]** In the event that either Party fails to provide accurate switched access detailed usage data to the other Party within 90 days after the recording date and the receiving Party is unable to bill and/or collect access revenues due to the sending Party's failure to provide such data within said time period, then the Party failing to send the data as specified herein shall be liable to the other Party in an amount equal to the unbillable or uncollectible revenues. Each company will provide complete documentation to the other to substantiate any claim of such unbillable or uncollectible access revenues. In the event that the Parties disagree as to the liability of the Initial Billing Party for such unbillable or uncollectible revenues, then either Party may invoke the Dispute Resolution process set forth in this Agreement.

**[BellSouth Version]** In the event that the Initial Billing Party, as defined in Section 7.4.4 herein, was provided the accurate switched access detailed usage data in a manner that allowed the Initial Billing Party to generate and provide such data to the Subsequent Billing Party in a reasonable timeframe and where the Initial Billing Party failed to provide notice to the Subsequent Billing Party of any inability to provide such data within a reasonable and nondiscriminatory timeframe and the Subsequent Billing Party is unable to bill and/or collect access revenues due to the Initial Billing Party's failure to provide such data within said time period, then the Initial Billing Party shall be liable to the other Party in an amount equal to the unbillable or uncollectible revenues. Each company will provide complete documentation to the other to substantiate any claim of such unbillable or uncollectible revenues. In the event that the Parties disagree as to the liability of the Initial Billing Party for such unbillable or uncollectible revenues, then either Party may invoke the Dispute Resolution process set forth in this Agreement.

- 10.7.5 The Initial Billing Company will retain for a minimum period of sixty (60) days, access message detail sufficient to recreate any data that is lost or damaged by the tandem provider company or any third party involved in processing or transporting data. Initial Billing Company agrees to recreate the lost or damaged data within forty-eight (48) hours of notification by the other or by an authorized third party handling the data.
- 10.7.6 Initial Billing Company also agrees to process the recreated data within forty-eight (48) hours of receipt at its data processing center.
- 10.7.7 All claims for unbillable or uncollectible revenue should be filed with the Initial Billing Company within 120 days of the date the receipt of the usage record.
- 10.7.8 The Initial Billing Party shall keep records of its billing activities relating to jointly-provided Intrastate and Interstate Switched Access Traffic Services in sufficient detail to permit the Subsequent Billing Party to, by formal or informal review or audit, to verify the accuracy and reasonableness of the jointly-provided access billing data provided by the Initial Billing Party. Each Party agrees to

cooperate in such formal or informal reviews or audits and further agrees to jointly review the findings of such reviews or audits in order to resolve any differences concerning the findings thereof. In the absence of mutual agreement otherwise, the Audit provisions set forth in Section 10.5.6.3 of this Attachment shall govern.

## 10.8 Transit Traffic

### 10.8.1 [NewSouth Version]

Each Party shall provide tandem switching and transport services for the other Party's Transit Traffic. Rates for Local Transit Traffic and ISP-Bound Transit Traffic shall be the applicable Call Transport and Termination charges (i.e., common transport and tandem switching charge; end office switching charge is not applicable) as set forth in Exhibit A to this Attachment. Rates for Switched Access Transit Traffic shall be the applicable charges as set forth in the applicable Party's Commission approved Interstate or Intrastate Switched Access tariffs as filed and effective with the FCC or Commission, or reasonable and non-discriminatory web-posted listing if the FCC or Commission does not require filing of a tariff. Billing associated with all Transit Traffic shall be pursuant to MECAB guidelines.

### [BellSouth Version]

Each Party shall provide tandem switching and transport services for the other Party's Transit Traffic. Rates for Local Transit Traffic and ISP-Bound Transit Traffic shall be the applicable Call Transport and Termination charges (i.e., common transport and tandem switching charges and **tandem intermediary charge**; end office switching charge is not applicable) as set forth in Exhibit A to this Attachment. Rates for Switched Access Transit Traffic shall be the applicable charges as set forth in the applicable Party's Commission approved Interstate or Intrastate Switched Access tariffs as filed and effective with the FCC or Commission, or reasonable and non-discriminatory web-posted listing if the FCC or Commission does not require filing of a tariff. Billing associated with all Transit Traffic shall be pursuant to MECAB guidelines.

10.8.2 Traffic between <<customer\_short\_name>> and Wireless Type 1 third parties or a third party CLEC utilizing BellSouth switching (including resellers and UNE-P providers) shall not be treated as Transit Traffic from a routing or billing perspective. Traffic originated by a Wireless Type 1 third party or a third party CLEC utilizing BellSouth switching (including resellers and UNE-P providers) shall be treated as BellSouth-originated traffic and BellSouth shall compensate <<customer\_short\_name>> for transport and termination of such traffic based on the classification of such traffic as Local Traffic, ISP-Bound Traffic, IntraLATA Toll or Switched Access Traffic in accordance with the terms of this Attachment.

10.8.3 Traffic between <<customer\_short\_name>> and Wireless Type 2A third parties shall not be treated as Transit Traffic from a routing or billing perspective until

BellSouth and the Wireless Type 2A carrier have the capability to properly meet-point-bill in accordance with MECAB guidelines. Until such time, such traffic originated by Wireless Type 2A third parties shall be treated as BellSouth-originated traffic and BellSouth shall compensate <<customer\_short\_name>> for transport and termination of such traffic based on the classification of such traffic as Local Traffic, ISP-Bound Traffic, IntraLATA Toll or Switched Access Traffic in accordance with the terms of this Attachment.

- 10.8.4 Traffic between BellSouth and Wireless Type 1 third parties or a third party CLEC utilizing <<customer\_short\_name>> switching shall not be treated as Transit Traffic from a routing or billing perspective. Such traffic originated by a Wireless Type 1 third party or a third party CLEC utilizing <<customer\_short\_name>> switching shall be treated as <<customer\_short\_name>>-originated traffic and <<customer\_short\_name>> shall compensate BellSouth for transport and termination of such traffic based on the classification of such traffic as Local Traffic, ISP-Bound Traffic, IntraLATA Toll or Switched Access Traffic in accordance with the terms of this Attachment.
- 10.8.5 Traffic between BellSouth and Wireless Type 2A third parties shall not be treated as Transit Traffic from a routing or billing perspective until <<customer\_short\_name>> and the Wireless Type 2A carrier have the capability to properly meet-point-bill in accordance with MECAB guidelines. Until such time, such traffic originated by Wireless Type 2A third parties shall be treated as <<customer\_short\_name>> -originated traffic and <<customer\_short\_name>> shall compensate BellSouth for transport and termination of such traffic based on the classification of such traffic as Local Traffic, ISP-Bound Traffic, IntraLATA Toll or Switched Access Traffic in accordance with the terms of this Attachment.
- 10.8.6 [Parties Disagree]
- [NewSouth Version] BellSouth agrees to deliver Transit Traffic originated by <<customer\_short\_name>> to the terminating carrier; provided, however, that <<customer\_short\_name>> is solely responsible for negotiating and executing any appropriate contractual agreements with the terminating carrier for the exchange of Transit Traffic through the BellSouth network. BellSouth will not be liable for any compensation to the terminating carrier or to <<customer\_short\_name>> for transiting <<customer\_short\_name>>-originated or terminated Transit Traffic. **Notwithstanding any other provision of this Attachment**, in the event that the terminating third party carrier imposes on BellSouth any charges or costs for the delivery of Transit Traffic originated by <<customer\_short\_name>>, <<customer\_short\_name>> shall reimburse BellSouth for all charges paid by BellSouth, **which BellSouth is contractually obligated to pay**, provided that BellSouth notifies and, upon request, provides <<customer\_short\_name>> with a copy of such an invoice, if available, or other equivalent supporting documentation (if an invoice is not available), and proof of payment and other applicable supporting documentation. BellSouth will provide

such notice and information in a timely, reasonable and nondiscriminatory manner. BellSouth shall diligently review, dispute and pay such third party invoices (or equivalent) in a manner that is at parity with its own practices for reviewing, disputing and paying such invoices (or equivalent) **when no similar reimbursement provision applies.** Additionally, the Parties agree that any billing to a third party or other telecommunications carrier under this section shall be pursuant to MECAB procedures.

**[BellSouth Version]** BellSouth agrees to deliver Transit Traffic originated by <<customer\_short\_name>> to the terminating carrier; provided, however, that <<customer\_short\_name>> is solely responsible for negotiating and executing any appropriate contractual agreements with the terminating carrier for the exchange of Transit Traffic through the BellSouth network. BellSouth will not be liable for any compensation to the terminating carrier or to <<customer\_short\_name>> for transiting <<customer\_short\_name>>-originated or terminated Transit Traffic. In the event that the terminating third party carrier imposes on BellSouth any charges or costs for the delivery of Transit Traffic originated by <<customer\_short\_name>>, <<customer\_short\_name>> shall reimburse BellSouth for all charges paid by BellSouth, provided that BellSouth notifies <<customer\_short\_name>> and, upon request, provides <<customer\_short\_name>> with a copy of such an invoice, if available, or other equivalent supporting documentation (if an invoice is not available), and proof of payment and other applicable supporting documentation. BellSouth will **use commercially reasonable efforts to** provide such notice and information in a timely, reasonable and nondiscriminatory manner. BellSouth shall diligently review, dispute and pay such third party invoices (or equivalent) in a manner that is at parity with its own practices for reviewing, disputing and paying such invoices (or equivalent) **under the same circumstances. Once <<customer\_short\_name>> reimburses BellSouth for any such payments, any disputes with respect to such charges shall be between <<customer\_short\_name>> and the terminating third party carrier.** Additionally, the Parties agree that any billing to a third party or other telecommunications carrier under this section shall be pursuant to MECAB procedures.

- 10.8.7 Except for as provided in 7.6.3 and 7.6.4, transit charges as described in this Attachment shall only be assessed on the carrier originating Transit Traffic and shall not be assessed on the terminating carrier.
- 10.8.8 Transit charges associated with the provisioning of toll free services (e.g., 800/888/877) shall be assessed upon the terminating carrier and shall not be imposed on the originating carrier.
- 10.9** Records Exchange and Misrouting of Traffic.
- 10.9.1 Misrouted Traffic.

- 10.9.1.1 The Parties shall route traffic to each other in a manner consistent with the Trunk Group Architectures selected by the Parties and as set forth in Section 4 of this Attachment 3, except as otherwise set forth in this Agreement (e.g., overflow) or in instances where a third party causes either Party to route traffic in a manner that is inconsistent with this Attachment.
- 10.9.1.2 In instances of misrouting, either Party may request that the Parties investigate, identify the cause of, and correct misrouting to the extent technically and economically feasible.
- 10.9.1.3 In the event that misrouting results in either Party's inability to bill or collect revenues from a third party and the Parties disagree as to the liability of the other Party for such revenues, then either Party may pursue the Dispute Resolution procedures set forth in this Agreement.

## 10.9.2 Records Exchange

- 10.9.2.1 Where feasible and appropriate, the Parties will generate and exchange all available messages for the purpose of billing third parties, including but not limited to CMRS providers and other LECs.

## 11. BASIC 911 AND E911 INTERCONNECTION

- 11.1 Basic 911 and E911 provides a caller access to the applicable emergency service bureau by dialing 911.

- 11.2 Basic 911 Interconnection. BellSouth will provide to <<customer\_short\_name>> a list consisting of each municipality that subscribes to Basic 911 service. The list will also provide, if known, the E911 conversion date for each municipality and, for network routing purposes, a ten-digit directory number representing the appropriate emergency answering position for each municipality subscribing to 911. <<customer\_short\_name>> will be required to arrange to accept 911 calls from its end users in municipalities that subscribe to Basic 911 service and translate the 911 call to the appropriate 10-digit directory number as stated on the list provided by BellSouth. <<customer\_short\_name>> will be required to route the call to the appropriate PSAP. When a municipality converts to E911 service, <<customer\_short\_name>> will be required to begin using E911 procedures.

- 11.3 E911 Interconnection. <<customer\_short\_name>> shall install a minimum of two (2) dedicated trunks originating from its Serving Wire Center and terminating to the appropriate E911 tandem. The Serving Wire Center must be in the same LATA as the E911 tandem. The dedicated trunks shall be, at a minimum, DS0 level trunks configured as part of a digital (1.544 Mb/s) interface (DS1 facility). The configuration shall use CAMA-type signaling with multifrequency (MF) pulsing that will deliver ANI with the voice portion of the call. If the user interface is digital, MF pulses as well as other AC signals shall be encoded per the u-255 Law convention. <<customer\_short\_name>> will be required to provide

BellSouth daily updates to the E911 database. <<customer\_short\_name>> will be required to forward 911 calls to the appropriate E911 tandem along with ANI based upon the current E911 end office to tandem homing arrangement as provided by BellSouth. If the E911 tandem trunks are not available, <<customer\_short\_name>> will be required to route the call to a designated seven (7)-digit or ten (10)-digit local number residing in the appropriate PSAP. This call will be transported over BellSouth's interoffice network and will not carry the ANI of the calling party. <<customer\_short\_name>> shall be responsible for providing BellSouth with complete and accurate data for submission to the 911/E911 database for the purpose of providing 911/E911 to its End Users.

- 11.4** Rates. Recurring and nonrecurring rates associated with trunk groups for 911 service are as set forth in Section 3.3.1 of this Attachment.
- 11.5** The detailed practices and procedures for 911/E911 interconnection are contained in the E911 Local Exchange Carrier Guide For Facility-Based Providers, which can be found at <http://www.interconnection.bellsouth.com/guides/e911/html/gcuge001/index.htm>.

## **12. FRAME RELAY SERVICE INTERCONNECTION**

- 12.1** In addition to the Local Interconnection services set forth above, BellSouth will offer a network to network Interconnection arrangement between BellSouth's and <<customer\_short\_name>>'s frame relay switches as set forth below. The following provisions will apply only to Frame Relay Service and Exchange Access Frame Relay Service and Managed Shared Frame Relay Service in those states in which <<customer\_short\_name>> is certified and providing Frame Relay Service as a Local Exchange Carrier and where traffic is being exchanged between <<customer\_short\_name>> and BellSouth Frame Relay Switches in the same LATA.
- 12.2** At <<customer\_short\_name>>'s request, the Parties agree to will establish two-way Frame Relay facilities between their respective Frame Relay Switches to the mutually agreed upon Frame Relay Service point(s) of interconnection (IP(s)) within the LATA. All IPs shall be within the same Frame Relay Network Serving Areas as defined in Section A40 of BellSouth's General Subscriber Service Tariff except as set forth in this Attachment.
- 12.3** Such interconnection will be established where BellSouth and <<customer\_short\_name>> have Frame Relay Switches in the same LATA. Where there are multiple Frame Relay switches in one central office, an interconnection with any one of the switches will be considered an interconnection with all of the switches at that central office for purposes of routing packet traffic.



- 12.4** The Parties agree to provision local and intraLATA Frame Relay Service and Exchange Access Frame Relay Service and Managed Shared Frame Relay Service (both intrastate and interstate) over Frame Relay interconnection facilities between the respective Frame Relay switches and the IPs.
- 12.5** The Parties agree to assess each other reciprocal charges for the facilities that each provides to the other according to the Percent Local Circuit Use Factor (PLCU), determined as follows:
- 12.5.1 If the data packets originate and terminate in locations in the same LATA, and are consistent with the local definitions of the Agreement, the traffic is considered local. Frame Relay framed packet data is transported within Virtual Circuits (VC). For the purposes of this Agreement, if all the data packets transported within a VC remain within the LATA, then consistent with the local definitions in this Agreement, the traffic on that VC is local (Local VC).
- 12.5.2 If the originating and terminating locations of the two-way packet data traffic are not in the same LATA, the traffic on that VC is interLATA (InterLATA VC).
- 12.5.3 The PLCU is determined by dividing the total number of Local VCs, by the total number of VCs on each Frame Relay facility. To facilitate implementation, <<customer\_short\_name>> may determine its PLCU in aggregate, by dividing the total number of Local VCs in a given LATA by the total number VCs in that LATA. The Parties agree to renegotiate the method for determining PLCU, at BellSouth's request, and within 90 days, if BellSouth notifies <<customer\_short\_name>> that it has found that this method does not adequately represent the PLCU.
- 12.5.4 If there are no VCs on a facility when it is billed, the PLCU will be zero.
- 12.5.5 BellSouth will provide the circuit between the Parties' respective Frame Relay Switches. The Parties will be compensated as follows: BellSouth will invoice, and <<customer\_short\_name>> will pay, the total nonrecurring and recurring charges for the circuit based upon the rates set forth in BellSouth's Interstate Access Tariff, FCC No. 1. <<customer\_short\_name>> will then invoice, and BellSouth will pay, an amount calculated by multiplying the BellSouth billed charges for the circuit by one-half of <<customer\_short\_name>>'s PLCU.
- 12.6** The Parties agree to compensate each other for Frame Relay network-to-network interface (NNI) ports based upon the NNI rates set forth in BellSouth's Interstate Access Tariff, FCC No. 1.. Compensation for each pair of NNI ports will be calculated as follows: BellSouth will invoice, and <<customer\_short\_name>> will pay, the total nonrecurring and recurring charges for the NNI port. <<customer\_short\_name>> will then invoice, and BellSouth will pay, an amount calculated by multiplying the BellSouth billed nonrecurring and recurring charges for the NNI port by <<customer\_short\_name>>'s PLCU.

- 12.7** Each Party agrees that there will be no charges to the other Party for its own subscriber's Permanent Virtual Circuit (PVC) rate elements for the local PVC segment from its Frame Relay switch to its own subscriber's premises. PVC rate elements include the Data Link Connection Identifier (DLCI) and Committed Information Rate (CIR).
- 12.8** For the PVC segment between the <<customer\_short\_name>> and BellSouth Frame Relay switches, compensation for the PVC charges is based upon the rates in BellSouth's Interstate Access Tariff, FCC No. 1.
- 12.9** Compensation for PVC rate elements will be calculated as follows:
- 12.9.1** If <<customer\_short\_name>> orders a VC connection between a BellSouth subscriber's PVC segment and a PVC segment from the BellSouth Frame Relay switch to the <<customer\_short\_name>> Frame Relay switch, BellSouth will invoice, and <<customer\_short\_name>> will pay, the total nonrecurring and recurring PVC charges for the PVC segment between the BellSouth and <<customer\_short\_name>> Frame Relay switches. If the VC is a Local VC, <<customer\_short\_name>> will then invoice and BellSouth will pay, the total nonrecurring and recurring PVC charges billed for that segment. If the VC is not local, no compensation will be paid to <<customer\_short\_name>> for the PVC segment.
- 12.9.2** If BellSouth orders a Local VC connection between a <<customer\_short\_name>> subscriber's PVC segment and a PVC segment from the <<customer\_short\_name>> Frame Relay switch to the BellSouth Frame Relay switch, BellSouth will invoice, and <<customer\_short\_name>> will pay, the total nonrecurring and recurring PVC and CIR charges for the PVC segment between the BellSouth and <<customer\_short\_name>> Frame Relay switches. If the VC is a Local VC, <<customer\_short\_name>> will then invoice and BellSouth will pay the total nonrecurring and recurring PVC and CIR charges billed for that segment. If the VC is not local, no compensation will be paid to <<customer\_short\_name>> for the PVC segment.
- 12.9.3** The Parties agree to compensate each other for requests to change a PVC segment or PVC service order record, according to the Feature Change charge as set forth in the BellSouth access tariff BellSouth Tariff FCC No. 1.
- 12.9.4** If <<customer\_short\_name>> requests a change, BellSouth will invoice and <<customer\_short\_name>> will pay a Feature Change charge for each affected PVC segment.
- 12.9.4.1** If BellSouth requests a change to a Local VC, <<customer\_short\_name>> will invoice and BellSouth will pay a Feature Change charge for each affected PVC segment.

- 12.9.5 The Parties agree to limit the sum of the CIR for the VCs on a DS1 NNI port to not more than three times the port speed, or not more than six times the port speed on a DS3 NNI port.
- 12.9.6 Except as expressly provided herein, this Agreement does not address or alter in any way either Party's provision of Exchange Access Frame Relay Service, Managed Shared Frame Relay Service or interLATA Frame Relay Service. All charges by each Party to the other for carriage of Exchange Access Frame Relay Service or interLATA Frame Relay Service are included in the BellSouth access tariff BellSouth Tariff FCC No. 1.
- 12.10** <<customer\_short\_name>> will identify and report quarterly to BellSouth the PLCU of the Frame Relay facilities it uses, per Section 11.5.3 above.
- 12.11** Either Party may request a review or audit of the various service components, consistent with the provisions of section E2 of the BellSouth State Access Services tariffs or Section 2 of the BellSouth FCC No.1 Tariff.

# Basic Architecture

Exhibit B

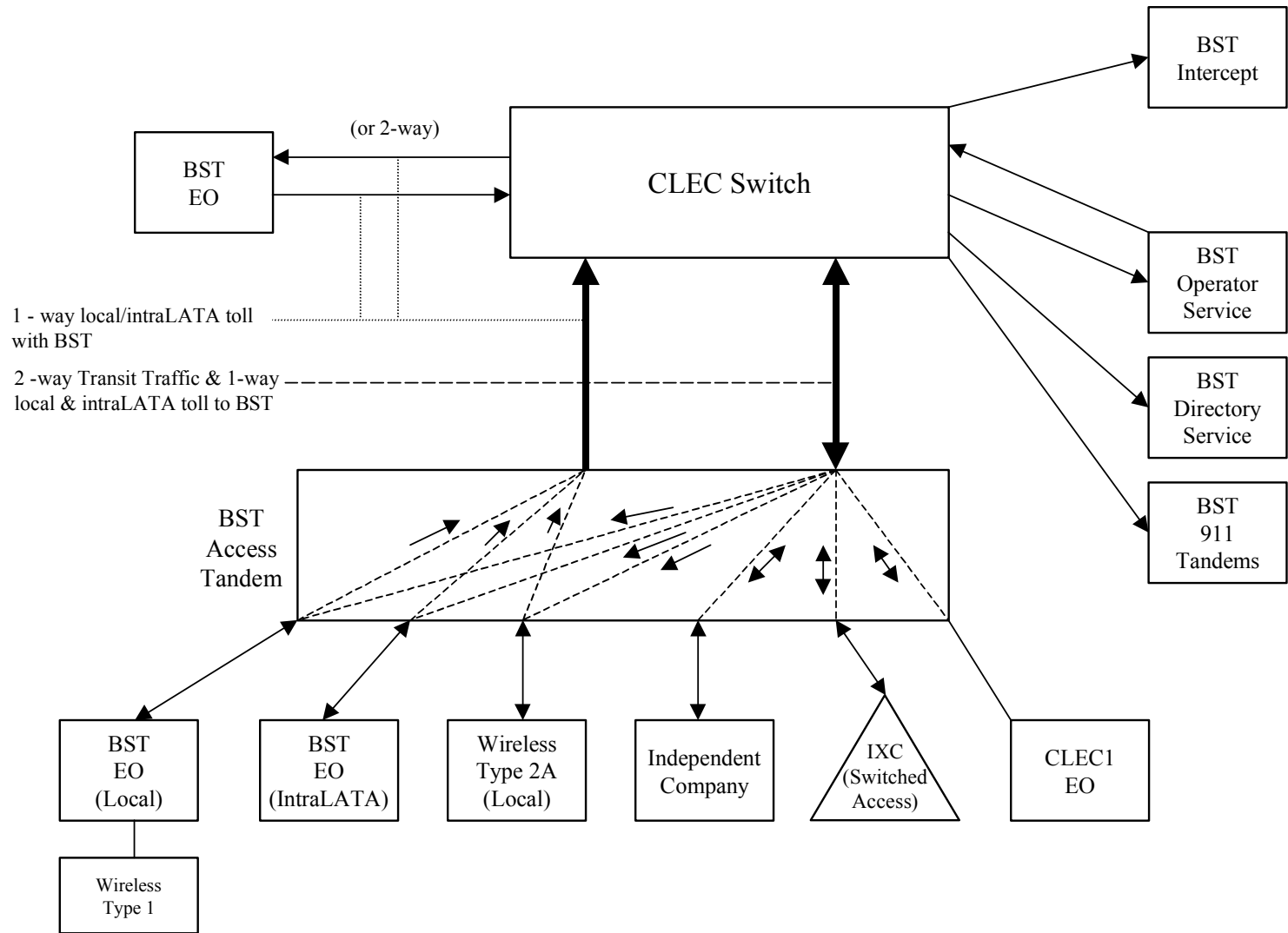

# One-Way Architecture

Exhibit C

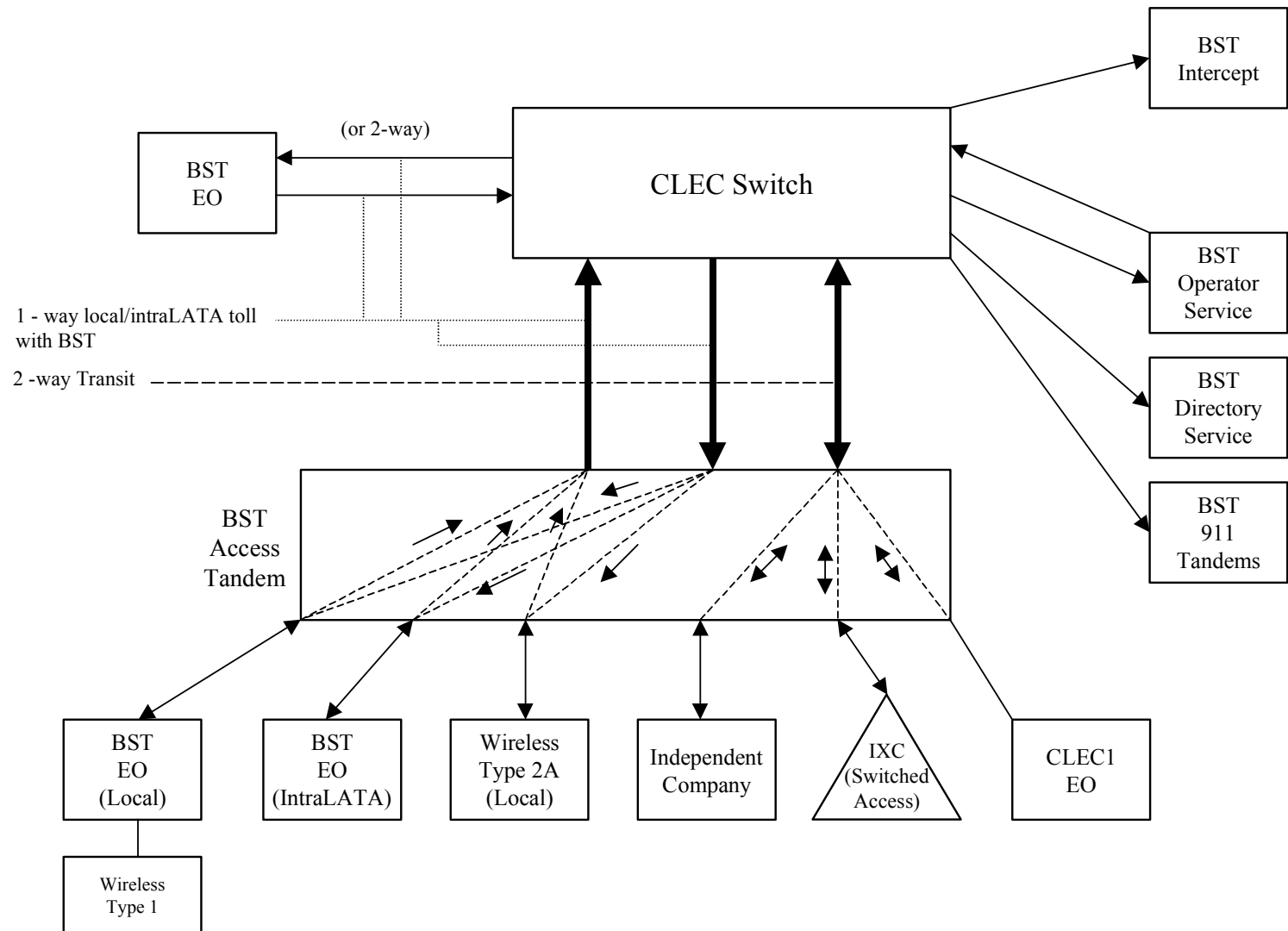

# Two-Way Architecture

Exhibit D

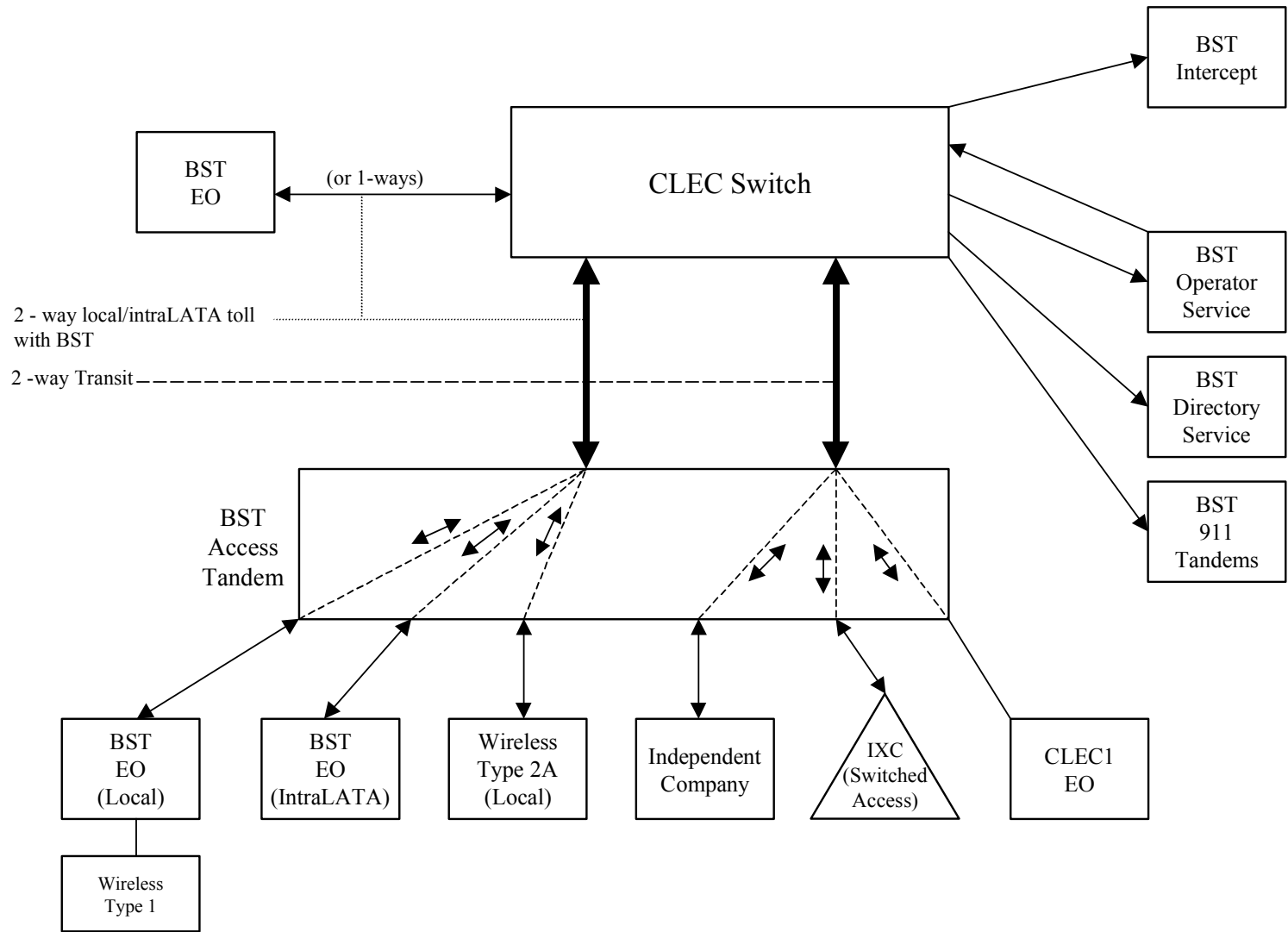

# Supergroup Architecture

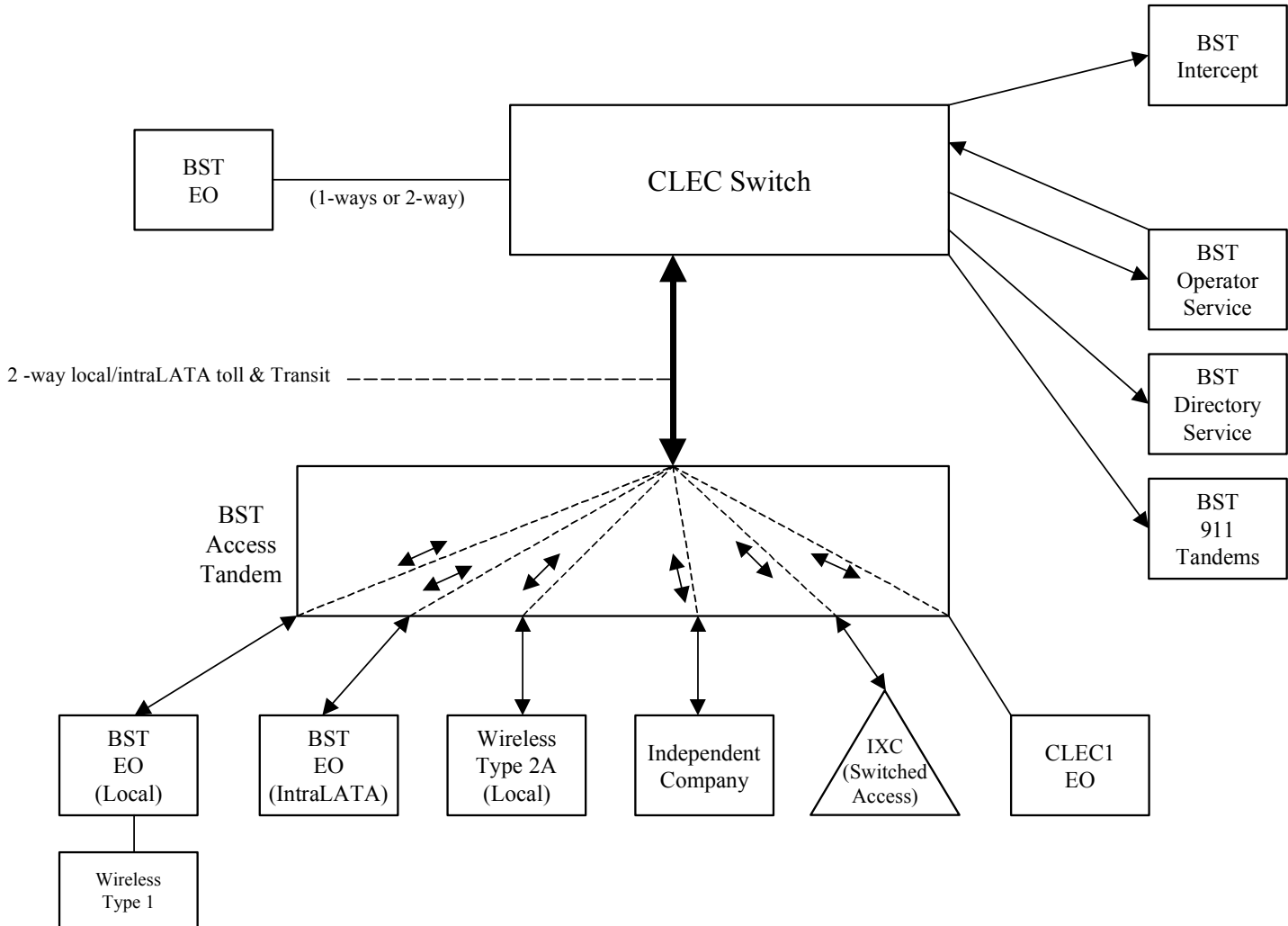





**Attachment 3**  
**Network Interconnection**

**TABLE OF CONTENTS**

**1. GENERAL.....3**

**2. DEFINITIONS: (FOR THE PURPOSE OF THIS ATTACHMENT) .....3**

**3. NETWORK INTERCONNECTION .....5**

**4. INTERCONNECTION TRUNK GROUP ARCHITECTURES.....10**

**5. NETWORK DESIGN AND MANAGEMENT FOR INTERCONNECTION .....18**

**6. SIGNALING.....18**

**7. FORECASTING FOR TRUNK PROVISIONING .....27**

**8. TRUNK UTILIZATION .....29**

**9. INTERFERENCE OR IMPAIRMENT .....30**

**10. COMPENSATION FOR CALL TRANSPORT AND TERMINATION FOR LOCAL TRAFFIC AND ISP-BOUND TRAFFIC. ....32**

**11. BASIC 911 AND E911 INTERCONNECTION.....41**

**12. FRAME RELAY SERVICE INTERCONNECTION .....42**

<b>Rates</b>	<b>Exhibit A</b>
<b>Basic Architecture</b>	<b>Exhibit B</b>
<b>One Way Architecture</b>	<b>Exhibit C</b>
<b>Two Way Architecture</b>	<b>Exhibit D</b>
<b>Supergroup Architecture</b>	<b>Exhibit E</b>

## NETWORK INTERCONNECTION

### 1. GENERAL

1.1 The Parties shall provide interconnection with each other's networks for the transmission and routing of telephone exchange service and exchange access on the following terms:

### 2. DEFINITIONS: (FOR THE PURPOSE OF THIS ATTACHMENT)

2.1 For purposes of this attachment only, the following terms shall have the definitions set forth below:

2.1.1 **Automatic Location Identification (ALI)** is a feature by which the address associated with the calling party's telephone number (ANI) is forwarded to the PSAP for display. Access to the ALI database is described in Attachment 2 to this Agreement.

2.1.2 **Automatic Number Identification (ANI)** corresponds to the seven (7)/ten (10)-digit telephone number assigned by the serving local exchange carrier.

2.1.3 **Basic 911 Service (B911)** routes a 9-1-1 call to one centralized answering location.

2.1.4 **Call Termination** has the meaning set forth for "termination" in 47 CFR § 51.701(d).

2.1.5 **Call Transport** has the meaning set forth for "transport" in 47 CFR § 51.701(c).

2.1.6 **Call Transport and Termination** is used collectively to mean the switching and transport functions from the Interconnection Point to the last point of switching.

2.1.7 **Common (Shared) Transport** is defined as the transport of the originating Party's traffic by the terminating Party over the terminating Party's common (shared) facilities between (1) the terminating Party's tandem switch and end office switch, (2) between the terminating Party's tandem switches, and/or (3) between the terminating Party's host and remote end office switches. All switches referred to herein must be registered in the Local Exchange Routing Guide (LERG).

2.1.8 **Cross Connect** is as defined in Attachment 4 of the Interconnection Agreement. If a Party provisions a cross connect for the purposes of interconnection under this Attachment 3, and such cross connect is not associated with a physical or virtual collocation arrangement, the provisioning party shall not charge for such cross connect.

- 2.1.9 **Dedicated Interoffice Facility** is defined as a switch transport facility between the <<customer\_short\_name>> Serving Wire Center (owned by BellSouth) and the first point of switching within the LATA on the BellSouth network or a switch transport facility between the BellSouth Serving Wire Center (owned by <<customer\_short\_name>>) and the first point of switching within the LATA on the <<customer\_short\_name>> network.
- 2.1.10 **End Office Switching** is defined as the function that establishes a communications path between the trunk side and line side of the End Office switch.
- 2.1.11 **Enhanced 911 Service** routes a 9-1-1 call to one centralized answering location and provides features not present in Basic 911 Service, including ANI and ALI and Selective Routing.
- 2.1.12 **Fiber Meet** is an interconnection arrangement whereby the Parties physically interconnect their networks via an optical fiber interface at which one Party's facilities, provisioning, and maintenance responsibility begins and the other Party's responsibility ends.
- 2.1.13 **Interconnection Point (IP)** is a physical telecommunications equipment interface that interconnects the networks of BellSouth and <<customer\_short\_name>>.
- 2.1.14 **ISP-Bound Traffic** is calls to an information service provider/enhanced service provider or Internet service provider (ISP) that are dialed by using a local dialing pattern (7 or 10 digits).
- 2.1.15 **Local Channel** is defined as a switched transport facility between a Party's Point of Presence and its designated Serving Wire Center where the Point of Presence is not located within the designated Serving Wire Center.
- 2.1.16 **Local Traffic** is defined as any traffic that is originated by an end user of one Party and is terminated to an end user of the other Party within a given LATA on that other Party's network, except for those calls that are originated or terminated through switched access arrangements. Additionally, Local Traffic includes any cross boundary, intrastate, interLATA or interstate interLATA calls established as a local call by the ruling regulatory body.
- 2.1.6 A **Point of Presence** is the physical location at which a Party establishes itself for obtaining access to the other Party's network.
- 2.1.7 **Public Safety Answering Point (PSAP)** is the answering location for 911 calls.

- 2.1.8 **Reciprocal Trunk Group** is defined as a one-way trunk group carrying BellSouth originated traffic to be terminated by <<customer\_short\_name>>.
- 2.1.9 **Selective Routing (SR)** is a standard feature that routes an E911 call from the 9-1-1 tandem to the designated PSAP based upon the address of the ANI of the calling party.
- 2.1.10 **Serving Wire Center** is defined as the wire center owned or leased by one Party from which the other Party would normally obtain dial tone for its Point of Presence.
- 2.1.17 **Tandem Switching** is defined as the function that establishes a communications path between two switching offices through a third switching office through the provision of trunk side to trunk side switching.
- 2.1.17.1 Consistent with FCC rules and orders, a <<customer\_short\_name>> switch shall be considered a tandem switch if it serves a geographic area comparable to that served by the relevant BellSouth tandem switch. <<customer\_short\_name>> shall provide to BellSouth supporting data to show such geographic comparability and if the Parties are unable to agree then the issue shall be resolved pursuant to the Dispute Resolution process set forth in the General Terms and Conditions of this Agreement.
- 2.1.18 **Transit Traffic** is traffic originating on one party's network that is switched and/or transported by the other Party and delivered to a third party's network, or traffic originating on a third party's network that is switched and/or transported by one party and delivered to the other Party's network.

### 3. NETWORK INTERCONNECTION

- 3.1 This Attachment pertains only to the provision of network interconnection where <<customer\_short\_name>> owns, leases from a third party or otherwise provides its own switch(es).
- 3.2 Network interconnection may be provided by the Parties via any technically feasible method and at any technically feasible point or points in accordance with applicable FCC and Commission rules and orders. In accordance with the terms of this Agreement, network interconnection may be provided via a DS0 where technically feasible and supported by applicable industry standards. Requests for interconnection via methods, such as OCn level interconnection, other than as set

forth in this Attachment may be made through the Bona Fide Request (BFR) process set out in Attachment 11 to this Agreement.

3.2.1 Requests for interconnection at a point or points other than as set forth in this Attachment may be made through the Bona Fide Request (BFR) process set out in Attachment 11 to this Agreement. At such time that BellSouth submits a request for interconnection that meets the requirements of this section, the Parties will negotiate the rates, terms, and conditions for such request.

3.2.2

Each Party is responsible for providing, engineering and maintaining the network on its side of the IP. The IP must be located within BellSouth's serving territory on BellSouth's network, unless otherwise agreed to by the parties or as otherwise set forth herein, in the LATA in which traffic is originating. The IP determines the point at which the originating Party shall pay the terminating Party for the Call Transport and Termination of Local Traffic and ISP-Bound Traffic.

3.2.3 Pursuant to the provisions of this Attachment, the Parties will endeavor in good faith to mutually agree on the location of the initial and additional IP(s) in a given LATA.

3.2.4 Notwithstanding any other provision of this Attachment and subject to the requirements for installing additional IPs, as set forth below, any IPs existing prior to the Effective Date of the Agreement will be accepted as initial IPs. BellSouth will not require re-grooming, however, <<customer\_short\_name>> may regroom and augment such IPs.

3.2.5 In selecting initial IP(s), both Parties will act in good faith and shall consider points that are efficient for both Parties. If the Parties are unable to agree on the location of the initial IP, in accordance with the terms and conditions set forth in this Attachment NuVox may designate an IP in the LATA for the delivery of its originated Local Traffic and ISP-bound Traffic and BellSouth will designate a BellSouth access tandem within the LATA as the IP for its originated Local Traffic and ISP-bound Traffic. BellSouth will not request the establishment of an IP where physical or virtual collocation space is not available or where BellSouth fiber connectivity is not available.

3.2.6 In selecting additional IP(s), both Parties will act in good faith and shall consider points that are efficient for both Parties. Additional IP(s) in a LATA may be established by mutual agreement of the Parties. Unless mutually agreed otherwise or direct end office trunking has been installed in accordance with Section 4.9.3.4.1. of this Attachment 3, an additional IP must be established if the following criteria are met: (1) the traffic between <<customer\_short\_name>> and BellSouth at the proposed additional IP must exceed a DS3, or 8.9 million

minutes of Local Traffic and ISP-Bound Traffic, per month for three consecutive months ; and (2) any end office to be designated as an IP must be more than 20 miles from an existing IP. BellSouth will not request the establishment of an IP where physical or virtual collocation space is not available or where BellSouth fiber connectivity is not available.

- 3.2.7 When the Parties agree to utilize two-way interconnection trunk groups for the exchange of Local Traffic, ISP-bound Traffic and IntraLATA Toll Traffic the Parties must agree to the location of the IP(s).
- 3.2.8 Upon written notification from the Party requesting the establishment of an additional IP, the receiving Party has twenty (20) business days to analyze, respond to, and negotiate in good faith regarding the establishment of such IP. Should the Parties disagree on how to proceed, the requesting Party may resort to the Dispute Resolution process set forth in the General Terms and Conditions.

### **3.3 Interconnection via Dedicated Facilities**

- 3.3.1 With the exception of Transit Traffic, the Parties shall institute a “bill and keep” compensation plan under which neither Party will charge the other Party recurring and nonrecurring charges for trunks (one-way or two-way), trunk ports and associated dedicated facilities for the exchange of Local Traffic (non-transit) and ISP-bound Traffic (non-transit), and 911 traffic. The appropriate rate elements that are subject to this “bill and keep” compensation plan are set forth in Exhibit A to this Attachment. Each Party has the obligation to install and maintain the appropriate trunks, trunk ports and associated facilities on its respective side of the IP and is responsible for bearing its costs for such trunks, trunk ports and associated facilities on its side of the IP. Both Parties, as appropriate, shall be compensated for the ordering of trunks, trunk ports and facilities used exclusively for transit traffic and for ancillary traffic types including, but not limited to OS/DA. To the extent <<customer\_short\_name>> purchased trunks, trunk ports, and facilities for OS/DA prior to the Effective Date and such trunks, trunk ports, and facilities were subject to a “bill and keep” arrangement prior to the Effective Date, such trunks, trunk ports, and facilities will continue to be subject to a “bill and keep” arrangement for four months from the Effective Date of this Agreement. The Parties agree that charges for such trunks, trunk ports and facilities are as set forth in Exhibit A to this Attachment or to the extent a rate associated with the interconnecting trunk group is not set forth in Exhibit A, the rate shall be as set forth in the appropriate Party’s tariff as filed and effective with the FCC or Commission, or reasonable and non-discriminatory web-posted listing if the FCC or Commission does not require filing of a tariff.

- 3.3.2 **Local Channel Facilities.** In lieu of providing facilities on its side of Interconnection Point or as part of Call Transport and Termination, either Party may purchase Local Channel facilities from the other Party pursuant to the provisions of this Attachment, where such facilities are available. The percentage of Local Channel Facilities utilized for Local Traffic and ISP-bound Traffic shall be determined based upon the application of the Percent Local Facility (PLF) Factor on a statewide basis. The charges applied to the percentage of Local Channel facilities used for Local Traffic and ISP-bound Traffic as determined by the PLF are set forth in Section 3.3.1 above. The remaining percentage of Local Channel Facilities shall be billed at the appropriate Party's intrastate or interstate tariff rates for switched access services or reasonable and non-discriminatory web-posted listing if the FCC or Commission does not require filing of a tariff.
- 3.3.3 **Dedicated Interoffice Facilities.** In lieu of providing facilities on its side of Interconnection Point or as part of Call Transport and Termination, either Party may purchase Dedicated Interoffice facilities from the other Party pursuant to the provisions of this Attachment, where such facilities are available. The percentage of Dedicated Interoffice Facilities utilized for Local Traffic and ISP-bound Traffic shall be determined based upon the application of the Percent Local Facility (PLF) Factor on a statewide basis. The charges applied to the percentage of Dedicated Interoffice facilities used for Local Traffic and ISP-bound Traffic as determined by the PLF are set forth in Section 3.3.1 above. The remaining percentage of the Dedicated Interoffice Facilities shall be billed at the appropriate Party's intrastate or interstate tariff rates for switched access services or reasonable and non-discriminatory web-posted listing if the FCC or Commission does not require filing of a tariff.
- 3.3.4 [Parties Disagree]
- [NuVox Version] In the event that a Party's Point of Presence is located within any serving wire center (i.e., switch location), such Party may interconnect to the other Party's switch via a Cross Connect or any other technically feasible means of interconnection.
- [BellSouth Version] If a Party provisions a cross connect for the purposes of interconnection under this Attachment 3, and such cross connect is not associated with a physical or virtual collocation arrangement, the provisioning party shall not charge for such cross connect.
- 3.3.5 The facilities and associated components as set forth in Exhibit A of this Attachment purchased pursuant to this Section 3 shall be ordered via the Access Service Request (ASR) process. The terms, conditions and rates for ordering charges (i.e., expedite, cancellation, and order modification charges) are as set forth in the BellSouth FCC Tariff No. 1. To the extent that BellSouth requests that <<customer\_short\_name>> submit an ASR for an augmentation to the



facilities purchased by <<customer\_short\_name>> from BellSouth but utilized for BellSouth's originated traffic, the Parties will work in good faith and make best efforts to ensure that the ASR submitted for such augmentations does not require expedition, cancellation or modification and in the event that <<customer\_short\_name>> incurs ordering charges, BellSouth and <<customer\_short\_name>> shall work cooperatively to determine which Party caused the incurrence of such charges and that Party shall be responsible for such charges.

### **3.4 Fiber Meet**

- 3.4.1 If <<customer\_short\_name>> elects to establish interconnection with BellSouth pursuant to a Fiber Meet Local Channel, <<customer\_short\_name>> and BellSouth shall jointly engineer, operate and maintain a Synchronous Optical Network (SONET) transmission system by which they shall interconnect their transmission and routing of Local Traffic via a Local Channel at either the, DS10, DS1, or DS3 level. The Parties shall work jointly to determine the specific transmission system. However, <<customer\_short\_name>>'s SONET transmission system must be compatible with BellSouth's equipment, and the Data Communications Channel (DCC) must be turned off, unless otherwise mutually agreed to by the Parties.
- 3.4.2 Each Party, at its own expense, shall procure, install and maintain the agreed upon SONET transmission system in its network.
- 3.4.3 The Parties shall agree to a Fiber Meet point between the BellSouth Serving Wire Center and the <<customer\_short\_name>> Serving Wire Center. The Parties shall deliver their fiber optic facilities to the Fiber Meet point with sufficient spare length to reach the fusion splice point for the Fiber Meet Point. BellSouth shall, at its own expense, provide and maintain the fusion splice point for the Fiber Meet. A building type Common Language Location Identification (CLLI) code will be established for each Fiber Meet point. All orders for interconnection facilities from the Fiber Meet point shall indicate the Fiber Meet point as the originating point for the facility.
- 3.4.4 Upon verbal request by <<customer\_short\_name>> and within a reasonable and non-discriminatory timeframe, BellSouth shall allow <<customer\_short\_name>> access to the fusion splice point for the Fiber Meet point for maintenance purposes on <<customer\_short\_name>>'s side of the Fiber Meet point.
- 3.4.5 Neither Party shall charge the other for its Local Channel portion of the Fiber Meet facility used for Local Traffic and ISP-bound Traffic. The percentage of Dedicated Interoffice Facilities utilized for Local Traffic and ISP-bound Traffic shall be determined based upon the application of the Percent Local Facility (PLF) Factor on a statewide basis. The remaining percentage of the Local Channel shall be billed at the appropriate Party's intrastate or interstate tariff rates

for switched access services or reasonable and non-discriminatory web-posted listing if the FCC or Commission does not require filing of a tariff.

#### **4. INTERCONNECTION TRUNK GROUP ARCHITECTURES**

- 4.1** BellSouth and <<customer\_short\_name>> shall establish interconnecting trunk groups and trunk group configurations between networks, including the use of one-way or two-way trunks in accordance with the following provisions set forth in this Attachment. For trunking purposes, traffic will be routed based on the digits dialed by the originating End User and in accordance with the LERG.
- 4.2** <<customer\_short\_name>> shall establish an interconnection trunk group(s) to at least one BellSouth access tandem within the LATA for the delivery of <<customer\_short\_name>>'s originated Local Traffic, ISP-bound Traffic and IntraLATA Toll Traffic and for the receipt and delivery of Transit Traffic. To the extent <<customer\_short\_name>> desires to deliver Local Traffic, ISP-bound Traffic, IntraLATA Toll Traffic and/or Transit Traffic to BellSouth access tandems within the LATA, other than the tandems(s) to which <<customer\_short\_name>> has established interconnection trunk groups, <<customer\_short\_name>> shall order Multiple Tandem Access, as described in this Attachment, to such other BellSouth access tandems.
- 4.2.1** Notwithstanding the forgoing, <<customer\_short\_name>> shall establish an interconnection trunk group(s) to all BellSouth access and local tandems in the LATA where <<customer\_short\_name>> has homed (i.e., assigned) its NPA/NXXs. <<customer\_short\_name>> shall home its NPA/NXXs on the BellSouth tandems that serve the exchange rate center areas to which the NPA/NXXs are assigned. The specified exchange rate center assigned to each BellSouth tandem is defined in the LERG. <<customer\_short\_name>> shall enter its NPA/NXX access and/or local tandem homing arrangements into the LERG.
- 4.3** Switched access traffic will be delivered to and from Interexchange Carriers (IXCs) based on <<customer\_short\_name>>'s NXX access tandem homing arrangement as specified by <<customer\_short\_name>> in the LERG.
- 4.4** Any <<customer\_short\_name>> interconnection request that (1) deviates from the interconnection trunk group architectures as described in this Agreement, (2) affects traffic delivered to <<customer\_short\_name>> from a BellSouth switch and (3) requires special BellSouth -switch translations and other network modifications will require <<customer\_short\_name>> to follow the procedures set forth in Attachment 11 to this Agreement. At such time that BellSouth submits a request for interconnection that meets the requirements of this section, the Parties will negotiate the rates, terms, and conditions for such request.

- 4.5 Unless the Parties mutually agree otherwise, <<customer\_short\_name>> shall be responsible for ordering and paying for any two way trunks carrying Transit Traffic. At such time as <<customer\_short\_name>> is providing the transit function for 15% or more of all Transit Traffic, <<customer\_short\_name>> will provide BellSouth with notification and supporting documentation that such threshold has been met. Within fifteen days following BellSouth's receipt of such notification and documentation, the Parties will begin negotiations for an alternative compensation arrangement for such two-way trunks carrying Transit Traffic. If the Parties are unable to agree to an alternative compensation arrangement within forty-five days of BellSouth's receipt of notification, then the Parties shall mutually agree to extend the negotiations or, absent mutual agreement, the Parties shall refer to the Dispute Resolution procedure set forth in this Agreement. Upon agreement of such alternative compensation arrangement, the Parties shall execute an amendment implementing such alternative compensation for two way trunks carrying Transit Traffic and the Parties shall "true-up" such arrangement to the date BellSouth received notification.
- 4.6 All trunk groups will be provisioned as Signaling System 7 (SS7) capable where technically feasible. If SS7 is not technically feasible, multi-frequency (MF) protocol signaling shall be used.
- 4.7 In cases where <<customer\_short\_name>> is also an IXC, the IXC's Feature Group D (FG D) trunk group(s) must remain separate from the local interconnection trunk group(s).
- 4.8 Each Party shall order interconnection trunks and trunk groups, including trunk and trunk group augmentations, via the ASR process. A Firm Order Confirmation (FOC) shall be returned to the ordering Party, after receipt of a valid, error free ASR, within the timeframes as set forth in Attachment 6, if applicable. Notwithstanding the foregoing, blocking situations and projects shall be project managed through BellSouth's Carrier Interconnection Switching Center (CISC) Project Management Group and <<customer\_short\_name>>'s equivalent trunking group and FOCs for such orders shall be returned in the timeframes negotiated by the Parties and suitable to the project. No additional charges shall be triggered due to the involvement of such project management. A project is defined as (1) a new trunk group (excluding augments to existing routes) or (2) a request for more than 96 trunks on a single or multiple group(s) in a given BellSouth local calling area.
- 4.9 **Interconnection Trunk Groups for Exchange of Local Traffic, ISP-Bound Traffic, and Transit Traffic**
- Upon mutual agreement of the Parties, the Parties' shall exchange Local Traffic, ISP-Bound Traffic, and Transit Traffic, where applicable, on two-way interconnection trunk group(s) with the quantity of trunks being mutually determined and the provisioning being jointly coordinated. Furthermore, the

Parties shall agree upon the IP(s) for two-way interconnection trunk groups transporting both Parties' Local Traffic, ISP-Bound Traffic and Transit Traffic, where applicable, as set forth in Section 3 above. Upon determination by the Parties, in a joint planning meeting, that such trunk groups shall be utilized, <<customer\_short\_name>> shall order such two-way trunks via the Access Service Request (ASR) process. BellSouth will use the Trunk Group Service Request (TGSR) to request changes in trunking. Furthermore, the Parties shall jointly review trunk performance and forecasts on a periodic basis, as set forth in Section 7 of this Attachment. The Parties' use of two-way interconnection trunk groups for the transport of Local Traffic, ISP-Bound Traffic and, IntraLATA Toll Traffic and Transit Traffic, where applicable, between the Parties does not preclude the Parties from mutually agreeing to establish additional one-way interconnection trunks for the delivery of its originated Local Traffic, ISP-Bound Traffic and, IntraLATA Toll Traffic and Transit Traffic to the other Party, where necessary, however, the proposal to establish such one-ways will be discussed by the Parties prior to the submission of an ASR.

#### 4.9.1 **BellSouth Access Tandem Interconnection**

Interconnection at a single access tandem provides access to those end offices subtending that access tandem (Intratandem Access). Access tandem interconnection is available for any of the following access tandem architectures.

##### 4.9.1.1 **Basic Architecture**

In the Basic Architecture, <<customer\_short\_name>>'s originating Local Traffic, ISP-bound Traffic and IntraLATA Toll Traffic and originating and terminating Transit Traffic is transported on a single two-way trunk group between <<customer\_short\_name>> and BellSouth access tandem(s) within a LATA to provide Intratandem Access. This trunk group carries Transit Traffic between <<customer\_short\_name>> and Independent Companies, Interexchange Carriers, other CLECs, and CMRS providers that have a Meet Point Billing arrangement with BellSouth, and other network providers with which <<customer\_short\_name>> desires to exchange traffic. This trunk group also carries <<customer\_short\_name>> originated Transit Traffic transiting a single BellSouth access tandem destined to third party tandems such as an Independent Company tandem or other CLEC tandem. BellSouth originated Local Traffic, ISP-bound Traffic and IntraLATA Toll Traffic is transported on a separate single one-way trunk group terminating to <<customer\_short\_name>>. Other trunk groups for operator services, directory assistance, and intercept may be established pursuant to the applicable BellSouth tariff if service is requested. The LERG shall be referenced for current routing and tandem serving arrangements. The Basic Architecture is illustrated in Exhibit B.

##### 4.9.1.2 **One-Way Trunk Group Architecture**

In One-Way Trunk Group architecture, the Parties interconnect using three separate trunk groups. A one-way trunk group provides Intratandem Access for

<<customer\_short\_name>>-originated Local Traffic, ISP-bound Traffic and IntraLATA Toll Traffic destined for BellSouth End Users. A second one-way trunk group carries BellSouth-originated Local Traffic, ISP-bound Traffic and IntraLATA Toll Traffic destined for <<customer\_short\_name>> End-Users. A two-way trunk group provides IntraTandem Access for <<customer\_short\_name>>'s originating and terminating Transit Traffic. This trunk group carries Transit Traffic between <<customer\_short\_name>> and Independent Companies, Interexchange Carriers, other CLECs, CMRS providers that have a Meet Point Billing arrangement with BellSouth, and other network providers with which <<customer\_short\_name>> desires to exchange traffic. This trunk group also carries <<customer\_short\_name>> originated Transit Traffic transiting a single BellSouth access tandem destined to third party tandems such as an Independent Company tandem or other CLEC tandem. BellSouth originated Local Traffic, ISP-bound Traffic and IntraLATA Toll Traffic is transported on a separate single one-way trunk group terminating to <<customer\_short\_name>>. Other trunk groups for operator services, directory assistance, and intercept may be established pursuant to the applicable BellSouth tariff if service is requested. The LERG contains current routing and tandem serving arrangements. The one-way trunk group architecture is illustrated in Exhibit C.

#### 4.9.1.3 **Two-Way Trunk Group Architecture**

The Two-Way Trunk Group Architecture establishes one two-way trunk group to provide IntraTandem Access for the exchange of Local Traffic, ISP-bound Traffic and IntraLATA Toll Traffic between <<customer\_short\_name>> and BellSouth. In addition, a separate two-way transit trunk group must be established for <<customer\_short\_name>>'s originating and terminating Transit Traffic. This trunk group carries Transit Traffic between <<customer\_short\_name>> and Independent Companies, Interexchange Carriers, other CLECs, CMRS providers that have a Meet Point Billing arrangement with BellSouth, and other network providers with which <<customer\_short\_name>> desires to exchange traffic. This trunk group also carries <<customer\_short\_name>> originated Transit Traffic transiting a single BellSouth access tandem destined to third party tandems such as an Independent Company tandem or other CLEC tandem. Either Party's originated traffic, may, in order to prevent or remedy a traffic blocking situations, be transported on a separate single one-way trunk group terminating to the other Party. Other trunk groups for operator services, directory assistance, and intercept may be established pursuant to the applicable BellSouth tariff if service is requested. The LERG contains current routing and tandem serving arrangements. The two-way trunk group architecture is illustrated in Exhibit D.

#### 4.9.1.4 **Supergroup Architecture**

In the Supergroup Architecture, the Parties' Local Traffic, ISP-bound Traffic and IntraLATA Toll Traffic and <<customer\_short\_name>>'s Transit Traffic are exchanged on a single two-way trunk group between <<customer\_short\_name>>

and BellSouth to provide Intratandem Access to <<customer\_short\_name>>. This trunk group carries Transit Traffic between <<customer\_short\_name>> and Independent Companies, Interexchange Carriers, other CLECs, CMRS providers that have a Meet Point Billing arrangement with BellSouth, and other network providers with which <<customer\_short\_name>> desires to exchange traffic. This trunk group also carries <<customer\_short\_name>> originated Transit Traffic transiting a single BellSouth access tandem destined to third party tandems such as an Independent Company tandem or other CLEC tandem. Either Party's originated traffic, may, in order to prevent or remedy a traffic blocking situations, be transported on a separate single one-way trunk group terminating to the other Party. Other trunk groups for operator services, directory assistance, and intercept may be established pursuant to the applicable BellSouth tariff if service is requested. The LERG shall be referenced for current routing and tandem serving arrangements. The Supergroup architecture is illustrated in Exhibit E.

#### 4.9.1.5 **Multiple Tandem Access Interconnection**

- 4.9.1.5.1 BellSouth Multiple Tandem Access ("MTA") provides for LATA wide BellSouth transport and termination of <<customer\_short\_name>>'s-originated local, ISP-bound and intraLATA toll traffic transported by BellSouth by establishing an interconnection trunk group at a BellSouth access tandem with routing through multiple BellSouth access tandems as required. <<customer\_short\_name>> must also establish an interconnection trunk group(s) at all BellSouth access tandems where <<customer\_short\_name>> NXXs are homed as described in Section 4.2.1 above. If <<customer\_short\_name>> does not have NXXs homed at any particular BellSouth access tandem within a LATA and elects not to establish an interconnection trunk group(s) at such BellSouth access tandem, <<customer\_short\_name>> can order MTA in each BellSouth access tandem within the LATA where it does have an interconnection trunk group(s) and BellSouth will terminate <<customer\_short\_name>>'s Local Traffic, ISP-bound Traffic and IntraLATA Toll Traffic to End-Users served through those BellSouth access tandems where <<customer\_short\_name>> does not have an interconnection trunk group(s).
- 4.9.1.5.2 <<customer\_short\_name>> may also utilize MTA to route its originated Transit Traffic; provided, however, that MTA may not be utilized to route switched access traffic that transits the BellSouth network to an Interexchange Carrier (IXC). Switched access traffic originated by or terminated to <<customer\_short\_name>> will be delivered to and from IXCs based on <<customer\_short\_name>>'s NXX access tandem homing arrangement as specified by <<customer\_short\_name>> in the LERG.
- 4.9.1.5.3 Compensation for MTA shall be at the applicable tandem switching and transport charges specified in Exhibit A to this Attachment and shall be billed in addition to

other applicable Call Transport and Termination charges. The Multiple Tandem Access rate element set forth in Exhibit A applies to the initial tandem only.

- 4.9.1.5.4 To the extent <<customer\_short\_name>> does not purchase MTA in a LATA served by multiple access tandems, <<customer\_short\_name>> must establish an interconnection trunk group(s) to every access tandem in the LATA to serve the entire LATA. To the extent <<customer\_short\_name>> routes its traffic in such a way that utilizes BellSouth's MTA service without properly ordering MTA, <<customer\_short\_name>> shall pay BellSouth the associated MTA charges. In a situation of tandem exhaust at any particular tandem, where the Parties choose MTA as an alternative routing plan, the Parties will negotiate appropriate rates, terms and conditions for MTA.

#### 4.9.2 **Local Tandem Interconnection**

- 4.9.2.1 Local Tandem Interconnection arrangement allows <<customer\_short\_name>> to establish an interconnection trunk group(s) at BellSouth local tandems for: (1) the delivery of <<customer\_short\_name>>-originated Local Traffic, ISP-bound Traffic and IntraLATA Toll Traffic transported and terminated by BellSouth to BellSouth end offices served by those BellSouth local tandems, and (2) for local Transit Traffic transported by BellSouth for third party network providers who have also established an interconnection trunk group(s) at those BellSouth local tandems.

- 4.9.2.2 When a specified local calling area is served by more than one BellSouth local tandem, <<customer\_short\_name>> must designate a "home" local tandem for each of its assigned NPA/NXXs and establish trunk connections to such local tandems. Additionally, <<customer\_short\_name>> may choose to establish an interconnection trunk group(s) at the BellSouth local tandems where it has no codes homing but is not required to do so. <<customer\_short\_name>> may deliver Local Traffic, ISP-bound Traffic and IntraLATA Toll Traffic to a "home" BellSouth local tandem that is destined for other BellSouth or third party network provider end offices subtending other BellSouth local tandems in the same local calling area where <<customer\_short\_name>> does not choose to establish an interconnection trunk group(s). It is <<customer\_short\_name>>'s responsibility to enter its own NPA/NXX local tandem homing arrangements into the LERG either directly or via a vendor in order for other third party network providers to determine appropriate traffic routing to <<customer\_short\_name>>'s codes. Likewise, <<customer\_short\_name>> shall obtain its routing information from the LERG.

- 4.9.2.3 Notwithstanding establishing an interconnection trunk group(s) to BellSouth's local tandems, <<customer\_short\_name>> must also establish an interconnection trunk group(s) to BellSouth access tandems within the LATA on which <<customer\_short\_name>> has NPA/NXXs homed for the delivery of Interexchange Carrier Switched Access (SWA) and toll traffic and traffic to Type

2A CMRS connections located at the access tandems. BellSouth shall not switch SWA traffic through more than one BellSouth access tandem. SWA, Type 2A CMRS or toll traffic routed to the local tandem in error will not be backhauled to the BellSouth access tandem for completion. A Type 2A CMRS interconnection is a connection between a BellSouth access tandem or local tandem office to an Mobile Service Provider's point of termination.

#### 4.9.3 **Direct End Office-to-End Office Interconnection**

- 4.9.3.1 Direct End Office-to-End Office one-way or two-way interconnection trunk groups allow for the delivery of a Party's originating Local Traffic, ISP-bound Traffic and IntraLATA Toll Traffic to the terminating Party on a direct end office-to-end office basis.
- 4.9.3.2 To the extent technically feasible and where appropriate, BellSouth will provide overflow routing consistent with how BellSouth overflows its traffic. The overflow will be based on the homing arrangements displayed in the LERG.
- 4.9.3.3 The Parties shall utilize direct end office-to-end office trunk groups under any one of the following conditions:
- 4.9.3.4 Tandem Exhaust - If a tandem through which the Parties are interconnected is unable to, or is forecasted to be unable to support additional traffic loads for the Parties or any other carrier for any period of time, the Parties will attempt to mutually agree on an end office trunking plan or an appropriate alternative routing plan that will alleviate the tandem capacity shortage and ensure completion of traffic between <<customer\_short\_name>> and BellSouth. (BST proposal)
- 4.9.3.4.1 Traffic Volume –To the extent either Party has the capability to measure the amount of traffic between <<customer\_short\_name>>'s ~~switch~~ switch and the BellSouth switch and where such traffic exceeds or is forecasted to exceed one DS3, or 8.9 million minutes of use, over a period of three consecutive months, then the Parties shall install and maintain direct end office trunking sufficient to handle such traffic volumes between a <<customer\_short\_name>> switch and a BellSouth switch. Either Party will install and maintain additional capacity between such points when overflow traffic exceeds or is forecasted to exceed one DS3, or 8.9 million minutes of use, of traffic per month. In the case of one-way trunking, additional trunking shall only be required by the Party whose trunking has achieved the preceding usage threshold.
- 4.9.3.4.2 Mutual Agreement - The Parties may install and maintain direct end office trunking upon mutual agreement in the absence of conditions (1) or (2) above.

#### 4.9.4 **Transit Traffic Trunk Group**



Transit Traffic trunks can either be two-way trunks or two one-way trunks ordered by <<customer\_short\_name>> to deliver and receive Transit Traffic. Establishing Transit Traffic trunks at BellSouth access and local tandems provides intratandem access to the third parties also interconnected at those tandems.

#### 4.9.5 Toll Free Traffic

4.9.5.1 If <<customer\_short\_name>> chooses BellSouth to perform the Service Switching Point (SSP) Function (i.e., handle Toll Free database queries) from BellSouth's switches, all <<customer\_short\_name>> originating Toll Free traffic will be routed over the Transit Traffic Trunk Group and shall be delivered using GR-394 format. Carrier Code "0110" and Circuit Code (to be determined for each LATA) shall be used for all such calls.

4.9.5.2 <<customer\_short\_name>> may choose to perform its own Toll Free database queries from its switch. In such cases, <<customer\_short\_name>> will determine the nature (local/intraLATA/interLATA) of the Toll Free call (local/IntraLATA/InterLATA) based on the response from the database. If the response from the database determines that the call is a BellSouth local or intraLATA Toll Free call, <<customer\_short\_name>> will route the post-query local or IntraLATA converted ten-digit local number to BellSouth over the local or intraLATA trunk group. If the response from the database determines that the is a third party (ICO, IXC, CMRS or other CLEC) local or intraLATA Toll Free call, <<customer\_short\_name>> will route the post-query local or intraLATA converted ten-digit local number to BellSouth over the Transit Traffic Trunk Group and <<customer\_short\_name>> shall provide to BellSouth a Toll Free billing record when appropriate. If the query reveals the call is an interLATA Toll Free call, <<customer\_short\_name>> will route the post-query interLATA Toll Free call (1) directly from its switch for carriers interconnected with its network or (2) over the Transit Traffic Trunk Group to carriers that are not directly connected to <<customer\_short\_name>>'s network but that are connected to BellSouth's access tandem.

4.9.5.3 All post-query Toll Free calls for which <<customer\_short\_name>> performs the SSP function, if delivered to BellSouth, shall be delivered using GR-394 format for calls destined to IXCs, and GR-317 format for calls destined to end offices that directly subtend a BellSouth access tandem within the LATA.

#### 4.9.5.4 **High Volume Calling (Mass Calling) Trunk Groups**

4.9.5.4.1 The Parties will cooperate to establish separate trunk groups, or provide some other means of protective controls (i.e., call gapping), for the completion of calls to high volume customers, such as radio contest lines.

4.9.5.4.2 Both parties agree to terminate each Party's mass calling codes as Local Traffic, where appropriate. The Parties agree that each will put in place controls for NXXs that are dedicated for media stimulated mass calling.

## **5. NETWORK DESIGN AND MANAGEMENT FOR INTERCONNECTION**

**5.1** Network Management and Changes. Both Parties will work cooperatively with each other to install and maintain the most effective and reliable interconnected telecommunications networks, including but not limited to, the exchange of toll-free maintenance contact numbers and escalation procedures. Both Parties agree to provide public notice of changes in the information necessary for the transmission and routing of services using their local exchange facilities or networks, as well as of any other changes that would affect the interoperability of those facilities and networks, to the extent required by, and in accordance with, applicable federal and state rules and regulations.

**5.2** Interconnection Technical Standards. The interconnection of all networks will be based upon accepted industry/national guidelines for transmission standards and traffic blocking criteria. Interconnecting facilities shall conform, at a minimum, to the telecommunications industry standard of DS-1 pursuant to Telcordia Standard No. TR-NWT-00499. Where <<customer\_short\_name>> chooses to utilize Signaling System 7 signaling, also known as Common Channel Signaling (SS7), SS7 connectivity is required between the <<customer\_short\_name>> switch and the BellSouth Signaling Transfer Point (STP). BellSouth will provide SS7 signaling using Common Channel Signaling Access Capability in accordance with the technical specifications set forth in the BellSouth Guidelines to Technical Publication, TR-TSV-000905. Facilities of each Party shall provide the necessary on-hook, off-hook answer and disconnect supervision and shall provide calling number ID (Calling Party Number) when technically feasible.

**5.3** Quality of Interconnection. The local interconnection for the transmission and routing of telephone exchange service and exchange access that each Party provides to each other will be at least Equal in Quality to what it provides to itself and any subsidiary or affiliate, where technically feasible, or to any other Party to which each Party provides local interconnection "Equal in Quality" shall have the meaning accorded in Section 51.305(a)(3) of the FCC's Rules, 47 C.F.R. § 51.305(a)(3).

**5.4** Network Management Controls. Both Parties will work cooperatively to apply sound network management principles by invoking appropriate network management controls (e.g., call gapping) to alleviate or prevent network congestion.

## **6 Signaling**

- 6.1 BellSouth shall offer access to signaling and access to BellSouth's signaling databases subject to compatibility testing and at the rates set forth in this Attachment. BellSouth may provide mediated access to BellSouth signaling systems and databases. Available signaling elements include signaling links, signal transfer points and service control points. Signaling functionality will be available with both A-link and B-link connectivity.
- 6.2 Signaling Link Transport
  - 6.2.1 Signaling Link Transport is a set of two (2) or four (4) dedicated 56 kbps transmission paths between <<customer\_short\_name>> designated Signaling Points of Interconnection that provide appropriate physical diversity.
  - 6.2.2 Technical Requirements
  - 6.2.3 Signaling Link Transport shall consist of full duplex mode 56 kbps transmission paths and shall perform in the following two ways:
    - 6.2.3.1 An "A-link" Signaling Link Transport is a connection between a switch or SCP and a Signaling Transfer Point switch pair; and
    - 6.2.3.2 As a "B-link" Signaling Link Transport is a connection between two Signaling Transfer Point switch pairs in different company networks (e.g., between two Signaling Transfer Point switch pairs for two CLECs).
  - 6.2.4 Signaling Link Transport shall consist of signaling link layers as follows:
    - 6.2.4.1 An A-link layer shall consist of two (2) links. There shall be no more than two (2) minutes down time per year for an A-link layer.
    - 6.2.4.2 A B-link layer shall consist of four (4) links. There shall be negligible (less than two (2) seconds) down time per year for a B-link layer.
  - 6.2.5 A signaling link layer shall satisfy interoffice and intraoffice diversity of facilities and equipment, such that:
    - 6.2.5.1 No single failure of facilities or equipment causes the failure of both links in an A-link layer (i.e., the links should be provided on a minimum of two (2) separate physical paths end-to-end); and
    - 6.2.5.2 No two (2) concurrent failures of facilities or equipment shall cause the failure of all four (4) links in a B-link layer (i.e., the links should be provided on a minimum of three (3) separate physical paths end-to-end).

## 6.2.6 Interface Requirements

6.2.6.1 There shall be a DS1 (1.544 Mbps) interface at <<customer\_short\_name>>'s designated SPOIs. Each 56 kbps transmission path shall appear as a DS0 channel within the DS1 interface.

## 6.3 Signaling Transfer Points (STPs)

6.3.1 A Signaling Transfer Point is a signaling network function that includes all of the capabilities provided by the signaling transfer point switches (STPs) and their associated signaling links that enables the exchange of SS7 messages among and between switching elements, database elements and STPs.

### 6.3.2 Technical Requirements

6.3.2.1 STPs shall provide access to BellSouth Local Switching or Tandem Switching and to BellSouth Service Control Points/Databases connected to BellSouth SS7 network. STPs also provide access to third-party local or tandem switching and third-party-provided STPs.

6.3.2.2 The connectivity provided by STPs shall fully support the functions of all other Network Elements connected to the BellSouth SS7 network. This includes the use of the BellSouth SS7 network to convey messages that neither originate nor terminate at a signaling end point directly connected to the BellSouth SS7 network (i.e., transit messages). When the BellSouth SS7 network is used to convey transit messages, there shall be no alteration of the Integrated Services Digital Network User Part or Transaction Capabilities Application Part (TCAP) user data that constitutes the content of the message.

6.3.2.3 STPs shall provide all functions of the SCCP necessary for Class 0 (basic connectionless) service, as defined in Telcordia ANSI Interconnection Requirements. This includes Global Title Translation (GTT) and SCCP Management procedures, as specified in ANSI T1.112.4. Where the destination signaling point is a <<customer\_short\_name>> or third party local or tandem switching system directly connected to BellSouth SS7 network, BellSouth shall perform final GTT of messages to the destination and SCCP Subsystem Management of the destination. In all other cases, BellSouth shall perform intermediate GTT of messages to a gateway pair of STPs in an SS7 network connected with the BellSouth SS7 network, and shall not perform SCCP Subsystem Management of the destination. If BellSouth performs final GTT to a <<customer\_short\_name>> database, then <<customer\_short\_name>> agrees to provide BellSouth with the Destination Point Code for <<customer\_short\_name>> database.

- 6.3.2.4 STPs shall provide all functions of the Operations, Maintenance and Administration Part (OMAP) as specified in applicable industry standard technical references, which may include, where available in BellSouth's network, MTP Routing Verification Test (MRVT); and SCCP Routing Verification Test (SRVT).
- 6.3.2.5 Where the destination signaling point is a BellSouth local or tandem switching system or database, or is a <<customer\_short\_name>> or third party local or tandem switching system directly connected to the BellSouth SS7 network, STPs shall perform MRVT and SRVT to the destination signaling point. In all other cases, STPs shall perform MRVT and SRVT to a gateway pair of STPs in an SS7 network connected with the BellSouth SS7 network. This requirement may be superseded by the specifications for Internetwork MRVT and SRVT when these become approved ANSI standards and available capabilities of BellSouth STPs.
- 6.4 SS7 Advanced Intelligent Network (AIN) Access
  - 6.4.1 Interface Requirements
    - 6.4.1.1 BellSouth shall provide the following STP options to connect <<customer\_short\_name>> or <<customer\_short\_name>>-designated local switching systems to the BellSouth SS7 network:
      - 6.4.1.1.1 An A-link interface from <<customer\_short\_name>> local switching systems; and,
      - 6.4.1.1.2 A B-link interface from <<customer\_short\_name>> local STPs.
    - 6.4.1.2 Each type of interface shall be provided by one or more layers of signaling links.
    - 6.4.1.3 The Signaling Point of Interconnection for each link shall be located at a cross connect element in the central office where the BellSouth STP is located.
    - 6.4.1.4 BellSouth shall provide intraoffice diversity between the SPOI and BellSouth STPs, so that no single failure of intraoffice facilities or equipment shall cause the failure of both B-links in a layer connecting to a BellSouth STP.
    - 6.4.1.5 STPs shall provide all functions of the MTP as defined in the applicable industry standard technical references.
  - 6.4.2 Message Screening
    - 6.4.2.1 BellSouth shall set message screening parameters so as to accept/send valid messages from <<customer\_short\_name>> local or tandem switching systems

destined to/from any signaling point within BellSouth's SS7 network where the <<customer\_short\_name>> switching system has a valid signaling relationship.

- 6.4.3 BellSouth shall set message screening parameters so as to accept/send valid messages from <<customer\_short\_name>> local or tandem switching systems destined to/from any signalling point or network accessed through BellSouth's SS7 network where the <<customer\_short\_name>> switching system has a valid signalling relationship.
- 6.5 Service Control Points/Databases
  - 6.5.1 Call Related Databases provide the storage of, access to, and manipulation of information required to offer a particular service and/or capability. BellSouth shall provide access to the following Databases: Local Number Portability, LIDB, Toll Free Number Database, Automatic Location Identification/Data Management System, and Calling Name Database. BellSouth also provides access to Service Creation Environment and Service Management System (SCE/SMS) application databases and Directory Assistance.
  - 6.5.2 A Service Control Point (SCP) is deployed in a SS7 network that executes service application logic in response to SS7 queries sent to it by a switching system also connected to the SS7 network. Service Management Systems provide operational interfaces to allow for provisioning, administration and maintenance of subscriber data and service application data stored in SCPs.
  - 6.5.3 Technical Requirements for SCPs/Databases
    - 6.5.3.1 BellSouth shall provide physical access to SCPs through the SS7 network and protocols with TCAP as the application layer protocol.
    - 6.5.3.2 BellSouth shall provide physical interconnection to databases via industry standard interfaces and protocols (e.g. SS7, ISDN and X.25).
    - 6.5.3.3 The reliability of interconnection options shall be consistent with requirements for diversity and survivability.
- 6.6 Local Number Portability Database
  - 6.6.1 The Permanent Number Portability (PNP) database supplies routing numbers for calls involving numbers that have been ported from one local service provider to another. BellSouth agrees to provide access to the PNP database at rates, terms and conditions as set forth by BellSouth and in accordance with an effective FCC or Commission directive.

- 6.7 SS7 Network Interconnection
- 6.7.1 SS7 Network Interconnection is the interconnection of <<customer\_short\_name>> local STPs or <<customer\_short\_name>> local or tandem switching systems with BellSouth STPs. This interconnection provides connectivity that enables the exchange of SS7 messages among BellSouth switching systems and databases, <<customer\_short\_name>> local or tandem switching systems, and other third-party switching systems directly connected to the BellSouth SS7 network.
- 6.7.2 The connectivity provided by SS7 Network Interconnection shall fully support the functions of BellSouth switching systems and databases and <<customer\_short\_name>> or other third-party switching systems with A-link access to the BellSouth SS7 network.
- 6.7.3 If traffic is routed based on dialed or translated digits between a <<customer\_short\_name>> local switching system and a BellSouth or other third-party local switching system, either directly or via a BellSouth tandem switching system, then it is a requirement that the BellSouth SS7 network convey via SS7 Network Interconnection the TCAP messages that are necessary to provide Call Management services (Automatic Callback, Automatic Recall, and Screening List Editing) between the <<customer\_short\_name>> local STPs and BellSouth or other third-party local switch.
- 6.7.4 SS7 Network Interconnection shall provide:
- 6.7.4.1 Signaling Data Link functions, as specified in ANSI T1.111.2;
- 6.7.4.2 Signaling Link functions, as specified in ANSI T1.111.3; and
- 6.7.4.3 Signaling Network Management functions, as specified in ANSI T1.111.4.
- 6.7.5 SS7 Network Interconnection shall provide all functions of the SCCP necessary for Class 0 (basic connectionless) service, as specified in ANSI T1.112. This includes GTT and SCCP Management procedures, as specified in ANSI T1.112.4. Where the destination signaling point is a BellSouth switching system or database, or is another third-party local or tandem switching system directly connected to the BellSouth SS7 network, SS7 Network Interconnection shall include final GTT of messages to the destination and SCCP Subsystem Management of the destination. Where the destination signaling point is a <<customer\_short\_name>> local or tandem switching system, SS7 Network Interconnection shall include intermediate GTT of messages to a gateway pair of <<customer\_short\_name>> local STPs, and shall not include SCCP Subsystem Management of the destination.

- 6.7.6 SS7 Network Interconnection shall provide all functions of the Integrated Services Digital Network User Part, as specified in ANSI T1.113.
- 6.7.7 SS7 Network Interconnection shall provide all functions of the TCAP, as specified in ANSI T1.114.
- 6.7.8 If Internetwork MRVT and SRVT become approved ANSI standards and available capabilities of BellSouth STPs, SS7 Network Interconnection may provide these functions of the OMAP.
- 6.7.9 Interface Requirements
  - 6.7.9.1 The following SS7 Network Interconnection interface options are available to connect <<customer\_short\_name>> or <<customer\_short\_name>>-designated local or tandem switching systems or STPs to the BellSouth SS7 network:
    - 6.7.9.1.1 A-link interface from <<customer\_short\_name>> local or tandem switching systems; and
    - 6.7.9.1.2 B-link interface from <<customer\_short\_name>> STPs.
  - 6.7.9.2 The SPOI for each link shall be located at a cross-connect element in the central office where the BellSouth STP is located. There shall be a DS1 or higher rate transport interface at each of the SPOIs. Each signaling link shall appear as a DS0 channel within the DS1 or higher rate interface.
  - 6.7.9.3 BellSouth shall provide intraoffice diversity between the SPOIs and the BellSouth STP, so that no single failure of intraoffice facilities or equipment shall cause the failure of both B-links in a layer connecting to a BellSouth STP.
  - 6.7.9.4 The protocol interface requirements for SS7 Network Interconnection include the MTP, ISDNUP, SCCP, and TCAP. These protocol interfaces shall conform to the applicable industry standard technical references. BellSouth does not have the capability to support any of the VoIP interfaces at the present time but is willing to negotiate new protocol interfaces.
  - 6.7.9.5 BellSouth shall set message screening parameters to accept messages from <<customer\_short\_name>> local or tandem switching systems destined to any signaling point in the BellSouth SS7 network with which the <<customer\_short\_name>> switching system has a valid signaling relationship.
- 6.8 Rate Categories And Applications



- 6.8.1 Message Charges
  - 6.8.1.1 Message charges, as set forth in 6.8.1.3, following, are assessed based on the type of message protocol, ISUP or TCAP. ISUP messages are associated with call set-up, while TCAP messages are used to query call related databases. ISUP message charges are assessed per terminating and originating call set-up request and TCAP message charges are assessed per data request.
  - 6.8.1.2 Message charges do not apply for TCAP messages switched by the regional STPs to the BellSouth provided 800 Data Base, LIDB or LNP Data Base. Query charges are assessed in lieu of message charges. Query charges for 800 Data Base are described in 6.9.5, following. When TCAP messages are destined for a foreign database, including a non-company provided LNP Data Base, message charges are assessed in lieu of query charges.
  - 6.8.1.3 Message charges are assessed in the following manner:
    - 6.8.1.3.1 Signal Formulation
      - 6.8.1.3.1.1 An ISUP Signal Formulation charge is assessed, per call set-up request, for terminating and originating formulating signaling messages in association with call set-up.
    - 6.8.1.3.2 Signal Transport
      - 6.8.1.3.2.1 An ISUP Signal Transport charge is assessed, per call set-up request, for signaling messages transported to and from the Company STP in association with call set-up.
      - 6.8.1.3.2.2 A TCAP Signal Transport charge is assessed per data request transported to a BellSouth STP and destined for a foreign database.
    - 6.8.1.3.3 Signal Switching
      - 6.8.1.3.3.1 An ISUP Signal Switching charge is assessed per call set-up request that is switched at the Company STP for terminating and originating messages .
      - 6.8.1.3.3.2 A TCAP Signal Switching charge is assessed for each data request that is switched by the Company STP and destined for a foreign network or database.
    - 6.8.1.3.4 Query Charges
      - 6.8.1.3.4.1 Query charges apply for queries to the Company LIDB and the LNP Data Base. When query charges apply for access to a Company provided database,

message charges are not assessed. LIDB Query Charges are described in 6.9.3, following and the LNP Data Base Query Charge is described in 6.9.4, following.

6.8.1.4 TCAP Bill and Keep

6.8.1.4.1 The Parties agree to treat signaling messages, signaling ports, and signaling links associated with local calls on a bill and keep basis.

6.8.1.4.2 <<customer\_short\_name>> and BellSouth agree that BellSouth will bill <<customer\_short\_name>> for signaling links, signaling ports, and signaling messages associated with interstate calls and with intrastate non-local calls in accordance with BellSouth's federal and state tariffs.

6.8.1.4.3 Beginning on the Effective Date of this Agreement and continuing until <<customer\_short\_name>> implements a system that is capable of counting the total number of signaling messages that traveled over facilities connecting <<customer\_short\_name>>'s CCS7 network and BellSouth's CCS7 network, BellSouth agrees that for the purposes of billing BellSouth for signaling messages for any given month, <<customer\_short\_name>> may use the total number of signaling messages that BellSouth's signaling bill to <<customer\_short\_name>> indicates have traveled over facilities connecting <<customer\_short\_name>>'s CCS7 network and BellSouth's CCS7 network for that same month. When <<customer\_short\_name>> implements a system that is capable of counting the total number of signaling messages that travel over facilities connecting <<customer\_short\_name>>'s CCS7 network and BellSouth's CCS7 network, <<customer\_short\_name>> will use the number of signaling messages counted by such system for the purposes of billing BellSouth for signaling messages, subject to BellSouth's right to contest the accuracy of the number of signaling messages counted by such system.

6.8.1.4.4 For the purposes of billing BellSouth for signaling messages, <<customer\_short\_name>> will apply the SPIU/SPLU provided by BellSouth (which can, at BellSouth's option, be the same as the PIU/PLU that BellSouth provides for minutes of use) to the number of messages calculated pursuant to Paragraph 6.8.1.4.3 above.

6.9 RATES AND CHARGES ASSOCIATED WITH SS7

6.9.1 Message Charge for ISUP Messages RATE

Per signaling message Bill & Keep

6.9.2 Message Charge for TCAP Messages RATE

Per signaling message Bill& Keep

6.9.3 LINE INFORMATION DATA BASE SERVICE

Per Access Transport Query RATE PER QUERY  
Exhibit A of Attachment 2 for  
UNE-P Only, Tariff Rate for All  
Others

Per Validation Service Query Exhibit A of Attachment 2 for  
UNE-P Only, Tariff Rate for All  
Others

Per OLNS Service Query Tariff Rate

6.9.4 LOCAL NUMBER PORTABILITY DATA BASE SERVICE

Per LNP Query Exhibit A of Attachment 2 for UNE-P Only

Negotiated Rates Pursuant to a Separate Agreement for All Others

6.9.5 800 DATA BASE SERVICE

Per 800 Query Exhibit A of Attachment 2 for  
UNE-P Only, Tariff Rate for All  
Others

## 7. FORECASTING FOR TRUNK PROVISIONING

7.1 Within six (6) months after execution of this Agreement, <<customer\_short\_name>> shall provide an initial ~~initial~~ interconnection trunk group forecast for each LATA in which it plans to provide service within BellSouth's region. BellSouth's reciprocal trunking forecasts will be based upon information provided by <<customer\_short\_name>> in the initial forecast. If <<customer\_short\_name>> refuses to provide such information, BellSouth shall provide reciprocal trunking forecasts based only on existing trunk group growth

and BellSouth's annual estimated percentage of BellSouth subscriber line growth. After the exchange of each Party's forecast, the Parties shall conduct a joint planning meeting to develop a joint interconnection trunk group forecast. Each forecast provided under this Section shall be deemed "Confidential Information" under the General Terms and Conditions of this Agreement.

- 7.2** The Parties shall use best efforts to make the initial and annual subsequent forecasts as accurate as possible based on reasonable engineering criteria. In addition, the Parties agree to proactively manage their interconnection trunking arrangements and use best efforts to timely notify each other if forecasted need quantities change or if a known or anticipated network event that may create a blocking situation is likely to occur during the time period between joint planning meetings. Joint planning meetings shall be conducted via conference call, unless mutual agreement is reached otherwise.
- 7.3** At a minimum, the joint forecast shall include the projected quantity of Transit Trunks, <<customer\_short\_name>>-to-BellSouth one-way trunks (<<customer\_short\_name>> Trunks), BellSouth-to-<<customer\_short\_name>> one-way trunks (Reciprocal Trunks) and/or two-way interconnection trunks, if the Parties have agreed to interconnect using two-way trunking to transport the Parties' Local Traffic, ISP-Bound Traffic and IntraLATA Toll Traffic. The quantities shall be projected for a minimum of six months and shall include an estimate of the current year plus the next two years total forecasted quantities. The Parties shall mutually develop Reciprocal Trunk Groups and/or two-way interconnection trunk forecast quantities.
- 7.4** All forecasts shall include, at a minimum, Access Carrier Terminal Location (ACTL), trunk group type (local/intraLATA toll, Transit, Operator Services, 911, etc.), A location/Z location (CLLI codes for <<customer\_short\_name>> location and BellSouth location where the trunks shall terminate), interface type (e.g., DS1), Direction of Signaling, Trunk Group Number, if known, (commonly referred to as the 2-6 code) and forecasted trunks in service each year (cumulative).
- 7.5** The submitting and development of interconnection trunk forecasts shall not replace the ordering process for local interconnection trunks. Each Party shall exercise its best efforts and act in good faith to plan for and provide the quantity of interconnection trunks mutually forecasted. However, the provision of the forecasted quantity of interconnection trunks is subject to trunk terminations and facility capacity existing at the time the trunk order is submitted and the provisioning Party shall not be responsible for a lack of interconnection trunks provided that the provisioning Party can establish that best efforts and good faith have been exercised.

## 8. TRUNK UTILIZATION

**8.1** For the Reciprocal Trunk Groups that cannot overflow traffic to another trunk group (Reciprocal Final Trunk Groups), BellSouth and <<customer\_short\_name>> shall monitor traffic on each interconnection Reciprocal Final Trunk Group that is ordered and installed. The Parties agree that the Reciprocal Final Trunk Groups will be utilized at 60 percent (60%) of the time consistent busy hour utilization level within 180 days of installation. The Parties agree that the Reciprocal Final Trunk Groups will be utilized at eighty percent (80%) of the time consistent busy hour utilization level within 365 days of installation. Any Reciprocal Final Trunk Group not meeting the minimum thresholds set forth in this Section are defined as "Under-utilized" trunks. BellSouth may disconnect any Under-utilized Reciprocal Final Trunk Groups and, for trunks not in excess of <<customer\_short\_name>>'s forecast, <<customer\_short\_name>> shall refund to BellSouth the associated nonrecurring and recurring trunk and facility charges paid by BellSouth, if any.

8.1.1 BellSouth's CISC will notify <<customer\_short\_name>> of any under-utilized Reciprocal Trunk Groups and the number of such trunk groups that BellSouth wishes to disconnect. BellSouth will provide supporting information either by email or facsimile to the designated <<customer\_short\_name>> interface. <<customer\_short\_name>> will provide concurrence with the disconnection in seven (7) business days or will provide specific information supporting why the trunks should not be disconnected. Such supporting information should include expected traffic volumes (including traffic volumes generated due to Local Number Portability) and the timeframes within which <<customer\_short\_name>> expects to need such trunks. BellSouth's CISC Project Manager and Circuit Capacity Manager will discuss the information with <<customer\_short\_name>> to determine if agreement can be reached on the number of Reciprocal Final Trunk Groups to be removed. If no agreement can be reached, BellSouth will issue disconnect orders to <<customer\_short\_name>>. Notwithstanding any other provision to this Agreement, the Parties will disconnect the underutilized trunks no sooner than two weeks after <<customer\_short\_name>> receives such disconnect orders, unless the parties mutually agree to do so sooner.

8.1.2 To the extent that any interconnection trunk group is utilized at a time-consistent busy hour of eighty percent (80%) or greater, the Parties may review the trunk groups and, if necessary, shall negotiate in good faith for the installation of augmented facilities.

**8.2** For the two-way trunk groups that cannot overflow traffic to another trunk group and other than alternate final trunk groups, BellSouth and <<customer\_short\_name>> shall monitor traffic on each interconnection trunk group that is ordered and installed. The Parties agree that within 180 days of the installation of the BellSouth two-way trunk or trunks, the trunks will be utilized at 60 percent (60%) of the time consistent busy hour utilization level. The Parties

agree that within 365 days of the installation of a trunk or trunks, the trunks will be utilized at eighty percent (80%) of the time consistent busy hour utilization level. Any trunk or trunks not meeting the minimum thresholds set forth in this Section are defined as "Under-utilized" trunks. BellSouth will request the disconnection of any Under-utilized two-way trunk(s) and, for trunks not in excess of <<customer\_short\_name>>'s forecast, <<customer\_short\_name>> shall refund to BellSouth the associated nonrecurring and recurring trunk and facility charges paid by BellSouth, if any.

- 8.2.1 BellSouth's LISC will notify <<customer\_short\_name>> of any under-utilized two-way trunk groups and the number of trunks that BellSouth wishes to disconnect. BellSouth will provide supporting information either by email or facsimile to the designated <<customer\_short\_name>> interface. <<customer\_short\_name>> will provide concurrence with the disconnection in seven (7) business days or will provide specific information supporting why the two-way trunks should not be disconnected. Such supporting information should include expected traffic volumes (including traffic volumes generated due to Local Number Portability) and the timeframes within which <<customer\_short\_name>> expects to need such trunks. BellSouth's CISC Project Manager and Circuit Capacity Manager will discuss the information with <<customer\_short\_name>> to determine if agreement can be reached on the number of trunks to be removed. If no agreement can be reached, <<customer\_short\_name>> will issue disconnect orders to BellSouth. Notwithstanding any other provision to this Agreement, the Parties will disconnect the underutilized trunks no sooner than two weeks after <<customer\_short\_name>> receives such disconnect orders, unless the parties mutually agree to do so sooner.
- 8.2.2 To the extent that any interconnection trunk group is utilized at a time-consistent busy hour of eighty percent (80%) or greater, the Parties shall review the trunk groups and, if necessary, shall negotiate in good faith for the installation of augmented facilities.

## **9. INTERFERENCE OR IMPAIRMENT**

- 9.1 As soon as possible and in no case later than twenty-four (24) hours after receipt of notification of blocking of traffic originated within the other Party's network, the Parties shall determine and begin work to implement reasonable corrective measures in a manner consistent with industry practices.
- 9.2 In the event of an outage or trouble in any arrangement, facility, or service being provided by BellSouth hereunder, BellSouth will follow procedures for isolating and clearing the outage or trouble that are no less favorable than those that apply to comparable arrangements, facilities, or services being provided by BellSouth to

itself, Affiliate or any other carrier whose network is connected to that of BellSouth.

**9.3** BellSouth will use best efforts to provide <<customer\_short\_name>> with at least thirty (30) days advance notification of scheduled maintenance activity. Upon such notice, <<customer\_short\_name>> may submit a reasonable request for additional information relevant to the scheduled maintenance activity and BellSouth shall provide such information to the extent the scheduled maintenance activity may impact <<customer\_short\_name>> and such information is reasonably necessary for <<customer\_short\_name>> to identify and analyze potential risks associated with such maintenance. BellSouth may expedite or delay scheduled maintenance as a result of unscheduled maintenance or other unforeseen events. In those instances where BellSouth will not perform scheduled maintenance at the announced times, BellSouth will make best efforts to provide <<customer\_short\_name>> with as much notice as is reasonably possible concerning the changed schedule.

**9.4** For switch software/processor updates, software upgrades/new releases to the SONET transport network elements, or other major scheduled events which might impact <<customer\_short\_name>>, BellSouth shall use best efforts to provide <<customer\_short\_name>> with at least thirty (30) days advance notification of scheduled maintenance activity. Upon such notice, <<customer\_short\_name>> may submit a reasonable request for additional information relevant to the scheduled maintenance activity and BellSouth shall provide such information to the extent the scheduled maintenance activity may impact <<customer\_short\_name>> and such information is reasonably necessary for <<customer\_short\_name>> to identify and analyze potential risks associated with such maintenance.

**9.5** BellSouth will provide <<customer\_short\_name>>'s Network Operations Center with written notice when translations are scheduled to be modified on <<customer\_short\_name>>'s trunk groups. BellSouth shall use best efforts to provide such notice 30 days in advance of such scheduled activity, or as close thereto as possible.

**9.6** [Parties Disagree]

[NuVox Version] Once <<customer\_short\_name>> determines that there is an outage that encompasses either a particular section of the network or the whole network, then <<customer\_short\_name>> shall generate a trouble ticket to the CISC. After issuing the trouble ticket, <<customer\_short\_name>> will notify the appropriate BellSouth representative in the CISC via telephone. <<customer\_short\_name>> may then send an email confirmation to such BellSouth representative. BellSouth will work cooperatively with <<customer\_short\_name>> to determine the appropriate steps to resolve such

outage. Additionally, <<customer\_short\_name>> will provide BellSouth with any applicable information that is necessary to resolve such outage and the Parties will work cooperatively to take all steps necessary to resolve the outage. **Upon request, BellSouth will provide a written root cause analysis report for all global outages, and for any trunk group outage that has occurred 3 or more times in a 60 day period. BellSouth shall use best efforts to provide such report within five (5) business days after the request for it is made.**

[BellSouth Version] Once <<customer\_short\_name>> determines that there is an outage that encompasses either a particular section of the network or the whole network, then <<customer\_short\_name>> shall generate a trouble ticket to the CISC. After issuing the trouble ticket, <<customer\_short\_name>> will notify the appropriate BellSouth representative in the CISC via telephone.

<<customer\_short\_name>> may then send an email confirmation to such BellSouth representative. BellSouth will work cooperatively with <<customer\_short\_name>> to determine the appropriate steps to resolve such outage. Additionally, <<customer\_short\_name>> will provide BellSouth with any applicable information that is necessary to resolve such outage and the Parties will work cooperatively to take all steps necessary to resolve the outage.

**<<customer\_short\_name>> may submit a reasonable request to BellSouth for a written analysis of the cause of any global outage affecting <<customer\_short\_name>>'s network. BellSouth shall use best efforts to provide such report within thirty (30) days of such request.**

## **10. COMPENSATION FOR CALL TRANSPORT AND TERMINATION FOR LOCAL TRAFFIC AND ISP-BOUND TRAFFIC.**

**10.1** Neither Party shall pay compensation to the other Party for per minute of use rate elements associated with the Call Transport and Termination of Local Traffic or ISP-bound Traffic.

**10.2** The appropriate elemental rates set forth in Exhibit A of this Attachment shall apply for Transit Traffic as described in this Attachment and to Multiple Tandem Access as described in this Attachment.

**10.3** Neither Party shall represent Switched Access Traffic, as defined in this Attachment, as Local Traffic or ISP-bound Traffic for purposes of determining compensation for the call.

**10.4** If <<customer\_short\_name>> assigns NPA/NXXs to specific BellSouth rate centers within the LATA and assigns numbers from those NPA/NXXs to <<customer\_short\_name>> End Users physically located outside of that LATA, BellSouth originated traffic that is not bound for an Internet Service Provider ("ISP") and originates from within the LATA where the NPA/NXXs are assigned and is delivered to a <<customer\_short\_name>> End User physically located outside of such LATA shall not be deemed Local Traffic. Further,



<<customer\_short\_name>> agrees to identify such traffic to BellSouth, to the extent technically feasible, and to compensate BellSouth for originating and transporting such non-local traffic to <<customer\_short\_name>> at BellSouth's switched access tariff rates.

- 10.4.1 The Parties have been unable to agree on the treatment of calls where <<customer\_short\_name>> assigns NPA/NXXs to specific BellSouth rate centers within the LATA and assigns numbers from those NPA/NXXs to <<customer\_short\_name>> End Users physically located outside of that LATA and such End Users are Internet Service Providers ("ISPs"). Notwithstanding the foregoing, and without waiving any rights with respect to either Party's position as to the treatment of such calls, the Parties agree that, for purposes of this Agreement, traffic delivered to an End User that is an ISP physically located outside of such LATA shall be considered ISP-bound Traffic as defined in this Attachment.

## **10.5 Jurisdictional Reporting**

- 10.5.1 **Percent Local Usage.** Each Party shall report to the other a Percent Local Usage (PLU) factor. The application of the PLU will determine the amount of Local/ISP-Bound minutes to be billed to the other Party. Local and ISP-bound Traffic shall be treated as Local for purposes of calculating the PLU. Requirements associated with PLU calculation and reporting shall be as set forth in BellSouth's Jurisdictional Factors Reporting Guide, attached hereto as Exhibit F.
- 10.5.2 **Percent Local Facility.** Each Party shall report to the other a Percent Local Facility (PLF) factor. The application of the PLF will determine the portion of switched dedicated transport to be billed per the local jurisdiction rates. The PLF shall be applied to Multiplexing, Local Channel and Interoffice Channel Switched Dedicated Transport utilized in the provision of local interconnection trunks. Requirements associated with PLF calculation and reporting shall be as set forth in BellSouth's Jurisdictional Factors Reporting Guide, attached hereto as Exhibit F.
- 10.5.3 **Percent Interstate Usage.** Each Party shall report to the other a Percent Interstate Usage (PIU) factor. Requirements associated with PIU calculation and reporting shall be as set forth in BellSouth's Jurisdictional Factors Reporting Guide, attached hereto as Exhibit F.
- 10.5.4 **Application of Factors.** After interstate and intrastate traffic percentages have been determined by use of PIU procedures, the PLU factor will be used for application and billing of Call Transport and Termination consistent with Section 7.1 of this Attachment.

- 10.5.5 Factors on file with BellSouth as of the Effective Date of this Agreement shall remain in place until such time as they are replaced by <<customer\_short\_name>> in accordance with this Attachment, or replaced in accordance with Section 10.5.6 of this Attachment 3.
- 10.5.6 **In Lieu of Jurisdictional Factors Reported.** Notwithstanding the provisions in Section 10.5.1, 10.5.2, and 10.5.3 above, where the terminating Party has message recording technology that identifies the jurisdiction of traffic terminated as defined in this Agreement, such information may, at the terminating Party's option, be utilized to determine the appropriate jurisdictional reporting factors, in lieu of those provided by the originating Party. In the event that the terminating Party opts to utilize its own data to determine jurisdictional reporting factors, such terminating Party shall notify the originating Party at least 30 days prior to the beginning of the calendar quarter in which the terminating Party will begin to utilize its own data.
- 10.5.6.1 Upon the request of the originating Party, the terminating Party shall provide supporting data for the jurisdictional factors proposed by the terminating Party to be used in lieu of those reported by the originating Party. The originating Party shall have 30 days to consent or object to the proposed replacement of reported factors. If the originating Party consents or fails to respond within 30 days, the terminating Party may proceed with the replacement of factors effective at the beginning of the calendar quarter. If the originating Party objects to the proposed replacement of reported factors, the Parties shall proceed as set forth below.
- 10.5.6.2 [Parties Disagree]
- [NuVox Version] Upon either Party's request, the Parties will work in good faith to resolve the discrepancy between the factors submitted by the originating party and those proposed by the terminating party pursuant to Section 7.2.5 above. In the event that the Parties are unable to mutually agree as to the appropriate resolution, the Parties may negotiate a mutually agreeable resolution based on the data specific to the traffic patterns of the originating party or either Party may request an audit of the factors in accordance with Section 7.2.9 below. In the event that negotiations and audits fail to resolve disputes between the parties, either Party may seek Dispute Resolution as set forth in the General Terms and Conditions. **While such a dispute is pending, factors reported by the originating Party shall remain in place, unless the Parties mutually agree otherwise.**
- [BellSouth Version] Upon either Party's request, the Parties will work in good faith to resolve the discrepancy between the factors submitted by the originating party and those proposed by the terminating party pursuant to Section 7.2.5 above. In the event that the Parties are unable to mutually agree as to the appropriate resolution, the Parties may negotiate a mutually agreeable resolution

based on the data specific to the traffic patterns of the originating party or either Party may request an audit of the factors in accordance with Section 7.2.9 below. In the event that negotiations and audits fail to resolve disputes between the parties, either Party may seek Dispute Resolution as set forth in the General Terms and Conditions. **While such a dispute is pending, the factors proposed by the terminating Party pursuant to Section 7.2.5 above shall be utilized, unless the Parties mutually agree otherwise.**

10.5.6.3 Audits. On thirty (30) days written notice, each Party must provide the other the ability and opportunity to conduct an annual audit of the jurisdictional reporting factors as reported or utilized pursuant to this Attachment 3 to ensure the proper billing of traffic. BellSouth and <<customer\_short\_name>> shall retain records of call detail for a minimum of nine months from which the jurisdictional reporting factors can be ascertained. The audit shall be conducted during normal business hours at an office designated by the Party being audited. Audit requests shall not be submitted more frequently than one (1) time per calendar year. The Parties shall use commercially reasonable efforts to complete audits in as timely a manner as possible. Audits shall be performed by a mutually acceptable independent auditor paid for by the Party requesting the audit. The jurisdictional reporting factors shall be adjusted based upon the audit results and shall apply for the quarter the audit was completed, for the quarter prior to the completion of the audit, and for the two quarters following the completion of the audit. If, as a result of an audit, either Party is found to have overstated jurisdictional reporting factors by twenty percentage points (20%) or more, that Party shall reimburse the auditing Party for the cost of the audit

## 10.6 Compensation for 8XX Traffic

10.6.1 Compensation for 8XX Traffic. Each Party shall compensate the other pursuant to the appropriate Switched Access charges, including the database query charge as applicable, as set forth in the providing Party's tariff, as filed and effective with the FCC or Commission, or reasonable and non-discriminatory web-posted listing if the FCC or Commission does not require filing of a tariff.

10.6.2 Records for 8XX Billing. Each Party will provide to the other the appropriate records necessary for billing intraLATA 8XX customers. The records provided will be in a standard EMI format.

10.6.3 8XX Access Toll Free Dialing Ten Digit Screening ("TFD"). BellSouth's provision of TFD to <<customer\_short\_name>> requires interconnection from <<customer\_short\_name>> to BellSouth's 8XX Signal Channel Point (SCP). Such interconnections shall be established pursuant to BellSouth's Common Channel Signaling Interconnection Guidelines and Telcordia's CCS Network Interface Specification document, TR-TSV-000905. <<customer\_short\_name>> shall establish SS7 interconnection at the BellSouth Local Signal Transfer Points

servicing the BellSouth 8XX SCPs that <<customer\_short\_name>> desires to query. The terms and conditions for 8XX TFD are set out in BellSouth's Intrastate Access Services Tariff.

- 10.7** Switched Access Traffic is defined as telephone calls requiring local transmission or switching services for the purpose of the origination or termination of Telephone Toll Service. Switched Access Traffic includes the following types of traffic: Feature Group A, Feature Group B, Feature Group C, Feature Group D, toll free access (e.g., 800/877/888), and 900 access services. Switched Access Traffic does not include Local Traffic and ISP-Bound Traffic originated by one Party and terminated by the other. The Parties have been unable to agree as to whether "Voice-Over-Internet Protocol" transmissions ("VOIP") which cross LATA boundaries constitute Switched Access Traffic. Notwithstanding the foregoing, and without waiving any rights with respect to either Party's position as to the jurisdictional nature of VOIP, the Parties agree amend this Agreement in accordance with the General Terms and Conditions of this Agreement to abide by any effective and applicable FCC rules and orders regarding the nature of such traffic and the compensation payable by the Parties for such traffic, if any.
- 10.7.1 If the BellSouth End User chooses <<customer\_short\_name>> as their presubscribed interexchange carrier, or if the BellSouth End User uses <<customer\_short\_name>> as an interexchange carrier on a 101XXXX basis, BellSouth will charge <<customer\_short\_name>> the appropriate BellSouth tariff charges for originating switched access services.
- 10.7.2 Where the originating Party delivers Switched Access Traffic to the terminating Party, the originating Party will pay the terminating Party terminating switched access charges as set forth in the providing Party's tariff, as filed and effective with the FCC or Commission, or reasonable and non-discriminatory web-posted listing if the FCC or Commission does not require filing of a tariff.
- 10.7.3 When one Party's end office switch, subtending the other Party's Access Tandem switch for receipt or delivery of switched access traffic, provides an access service connection to or from an interexchange carrier ("IXC") by either a direct trunk group to the IXC utilizing the other Party's facilities, or via the other Party's tandem switch, each Party will provide its own access services to the IXC and bill on a multi-bill, multi-tariff meet-point basis. Each Party will bill its own access services rates to the IXC with the exception of the interconnection charge. The interconnection charge will be billed by the Party providing the end office function. The Parties will use the Multiple Exchange Carrier Access Billing (MECAB) guidelines to establish meet point billing for all applicable traffic. . Thirty (30)-day billing periods will be employed for these arrangements. To the extent either party is providing the tandem function, that party (i.e., Initial Billing Company) agrees to provide to the other company (i.e., Subsequent Billing Company), as defined in MECAB, at no charge, the switched access detailed

usage data within no more than sixty (60) days after the recording date where technically feasible. Each company will notify the other when it determines that it is not feasible to meet these requirements so that the customers may be notified for any necessary revenue accrual associated with the significantly delayed recording or billing. As business requirements change, data reporting requirements may be modified as necessary, by mutual agreement of the Parties or per a change in industry standards.

10.7.4 [Parties Disagree]

**[NuVox Version]** In the event that either Party fails to provide accurate switched access detailed usage data to the other Party within 90 days after the recording date and the receiving Party is unable to bill and/or collect access revenues due to the sending Party's failure to provide such data within said time period, then the Party failing to send the data as specified herein shall be liable to the other Party in an amount equal to the unbillable or uncollectible revenues. Each company will provide complete documentation to the other to substantiate any claim of such unbillable or uncollectible access revenues. In the event that the Parties disagree as to the liability of the Initial Billing Party for such unbillable or uncollectible revenues, then either Party may invoke the Dispute Resolution process set forth in this Agreement.

**[BellSouth Version]** In the event that the Initial Billing Party, as defined in Section 7.4.4 herein, was provided the accurate switched access detailed usage data in a manner that allowed the Initial Billing Party to generate and provide such data to the Subsequent Billing Party in a reasonable timeframe and where the Initial Billing Party failed to provide notice to the Subsequent Billing Party of any inability to provide such data within a reasonable and nondiscriminatory timeframe and the Subsequent Billing Party is unable to bill and/or collect access revenues due to the Initial Billing Party's failure to provide such data within said time period, then the Initial Billing Party shall be liable to the other Party in an amount equal to the unbillable or uncollectible revenues. Each company will provide complete documentation to the other to substantiate any claim of such unbillable or uncollectible revenues. In the event that the Parties disagree as to the liability of the Initial Billing Party for such unbillable or uncollectible revenues, then either Party may invoke the Dispute Resolution process set forth in this Agreement.

10.7.5 The Initial Billing Company will retain for a minimum period of sixty (60) days, access message detail sufficient to recreate any data that is lost or damaged by the tandem provider company or any third party involved in processing or transporting data. Initial Billing Company agrees to recreate the lost or damaged data within forty-eight (48) hours of notification by the other or by an authorized third party handling the data.

- 10.7.6 Initial Billing Company also agrees to process the recreated data within forty-eight (48) hours of receipt at its data processing center.
- 10.7.7 All claims for unbillable or uncollectible revenue should be filed with the Initial Billing Company within 120 days of the date the receipt of the usage record.
- 10.7.8 The Initial Billing Party shall keep records of its billing activities relating to jointly-provided Intrastate and Interstate Switched Access Traffic Services in sufficient detail to permit the Subsequent Billing Party to, by formal or informal review or audit, to verify the accuracy and reasonableness of the jointly-provided access billing data provided by the Initial Billing Party. Each Party agrees to cooperate in such formal or informal reviews or audits and further agrees to jointly review the findings of such reviews or audits in order to resolve any differences concerning the findings thereof. In the absence of mutual agreement otherwise, the Audit provisions set forth in Section 10.5.6.3 of this Attachment shall govern.

## **10.8 Transit Traffic**

- 10.8.1 Each Party shall provide tandem switching and transport services for the other Party's Transit Traffic. Rates for Local Transit Traffic and ISP-Bound Transit Traffic shall be the applicable Call Transport and Termination charges (i.e., common transport and tandem switching charges and tandem intermediary charge; end office switching charge is not applicable) as set forth in Exhibit A to this Attachment. Rates for Switched Access Transit Traffic shall be the applicable charges as set forth in the applicable Party's Commission approved Interstate or Intrastate Switched Access tariffs as filed and effective with the FCC or Commission, or reasonable and non-discriminatory web-posted listing if the FCC or Commission does not require filing of a tariff. Billing associated with all Transit Traffic shall be pursuant to MECAB guidelines.
- 10.8.2 Traffic between <<customer\_short\_name>> and Wireless Type 1 third parties or a third party CLEC utilizing BellSouth switching (including resellers and UNE-P providers) shall not be treated as Transit Traffic from a routing or billing perspective. Traffic originated by a Wireless Type 1 third party or a third party CLEC utilizing BellSouth switching (including resellers and UNE-P providers) shall be treated as BellSouth-originated traffic and BellSouth shall compensate <<customer\_short\_name>> for transport and termination of such traffic based on the classification of such traffic as Local Traffic, ISP-Bound Traffic, IntraLATA Toll or Switched Access Traffic in accordance with the terms of this Attachment.
- 10.8.3 Traffic between <<customer\_short\_name>> and Wireless Type 2A third parties shall not be treated as Transit Traffic from a routing or billing perspective until BellSouth and the Wireless Type 2A carrier have the capability to properly meet-point-bill in accordance with MECAB guidelines. Until such time, such traffic originated by Wireless Type 2A third parties shall be treated as BellSouth-

originated traffic and BellSouth shall compensate <<customer\_short\_name>> for transport and termination of such traffic based on the classification of such traffic as Local Traffic, ISP-Bound Traffic, IntraLATA Toll or Switched Access Traffic in accordance with the terms of this Attachment.

10.8.4 Traffic between BellSouth and Wireless Type 1 third parties or a third party CLEC utilizing <<customer\_short\_name>> switching shall not be treated as Transit Traffic from a routing or billing perspective. Such traffic originated by a Wireless Type 1 third party or a third party CLEC utilizing <<customer\_short\_name>> switching shall be treated as <<customer\_short\_name>>-originated traffic and <<customer\_short\_name>> shall compensate BellSouth for transport and termination of such traffic based on the classification of such traffic as Local Traffic, ISP-Bound Traffic, IntraLATA Toll or Switched Access Traffic in accordance with the terms of this Attachment.

10.8.5 Traffic between BellSouth and Wireless Type 2A third parties shall not be treated as Transit Traffic from a routing or billing perspective until <<customer\_short\_name>> and the Wireless Type 2A carrier have the capability to properly meet-point-bill in accordance with MECAB guidelines. Until such time, such traffic originated by Wireless Type 2A third parties shall be treated as <<customer\_short\_name>> -originated traffic and <<customer\_short\_name>> shall compensate BellSouth for transport and termination of such traffic based on the classification of such traffic as Local Traffic, ISP-Bound Traffic, IntraLATA Toll or Switched Access Traffic in accordance with the terms of this Attachment.

10.8.6 [Parties Disagree]

[NuVox Version] BellSouth agrees to deliver Transit Traffic originated by <<customer\_short\_name>> to the terminating carrier; provided, however, that <<customer\_short\_name>> is solely responsible for negotiating and executing any appropriate contractual agreements with the terminating carrier for the exchange of Transit Traffic through the BellSouth network. BellSouth will not be liable for any compensation to the terminating carrier or to <<customer\_short\_name>> for transiting <<customer\_short\_name>>-originated or terminated Transit Traffic. **Notwithstanding any other provision of this Attachment**, in the event that the terminating third party carrier imposes on BellSouth any charges or costs for the delivery of Transit Traffic originated by <<customer\_short\_name>>, <<customer\_short\_name>> shall reimburse BellSouth for all charges paid by BellSouth, **which BellSouth is contractually obligated to pay**, provided that BellSouth notifies and, upon request, provides <<customer\_short\_name>> with a copy of such an invoice, if available, or other equivalent supporting documentation (if an invoice is not available), and proof of payment and other applicable supporting documentation. BellSouth will provide such notice and information in a timely, reasonable and nondiscriminatory manner. BellSouth shall diligently review, dispute and pay such third party invoices (or equivalent) in a manner that is at parity with its own practices for

reviewing, disputing and paying such invoices (or equivalent) **when no similar reimbursement provision applies**. Additionally, the Parties agree that any billing to a third party or other telecommunications carrier under this section shall be pursuant to MECAB procedures.

**[BellSouth Version]** BellSouth agrees to deliver Transit Traffic originated by <<customer\_short\_name>> to the terminating carrier; provided, however, that <<customer\_short\_name>> is solely responsible for negotiating and executing any appropriate contractual agreements with the terminating carrier for the exchange of Transit Traffic through the BellSouth network. BellSouth will not be liable for any compensation to the terminating carrier or to <<customer\_short\_name>> for transiting <<customer\_short\_name>>-originated or terminated Transit Traffic. In the event that the terminating third party carrier imposes on BellSouth any charges or costs for the delivery of Transit Traffic originated by <<customer\_short\_name>>, <<customer\_short\_name>> shall reimburse BellSouth for all charges paid by BellSouth, provided that BellSouth notifies <<customer\_short\_name>> and, upon request, provides <<customer\_short\_name>> with a copy of such an invoice, if available, or other equivalent supporting documentation (if an invoice is not available), and proof of payment and other applicable supporting documentation. BellSouth will **use commercially reasonable efforts to** provide such notice and information in a timely, reasonable and nondiscriminatory manner. BellSouth shall diligently review, dispute and pay such third party invoices (or equivalent) in a manner that is at parity with its own practices for reviewing, disputing and paying such invoices (or equivalent) **under the same circumstances. Once <<customer\_short\_name>> reimburses BellSouth for any such payments, any disputes with respect to such charges shall be between <<customer\_short\_name>> and the terminating third party carrier.** Additionally, the Parties agree that any billing to a third party or other telecommunications carrier under this section shall be pursuant to MECAB procedures.

- 10.8.7 Except for as provided in 7.6.3 and 7.6.4, transit charges as described in this Attachment shall only be assessed on the carrier originating Transit Traffic and shall not be assessed on the terminating carrier.
- 10.8.8 Transit charges associated with the provisioning of toll free services (e.g., 800/888/877) shall be assessed upon the terminating carrier and shall not be imposed on the originating carrier.
- 10.9** Records Exchange and Misrouting of Traffic.
  - 10.9.1 Misrouted Traffic.
    - 10.9.1.1 The Parties shall route traffic to each other in a manner consistent with the Trunk Group Architectures selected by the Parties and as set forth in Section 4 of this



Attachment 3, except as otherwise set forth in this Agreement (e.g., overflow) or in instances where a third party causes either Party to route traffic in a manner that is inconsistent with this Attachment.

- 10.9.1.2 In instances of misrouting, either Party may request that the Parties investigate, identify the cause of, and correct misrouting to the extent technically and economically feasible.
- 10.9.1.3 In the event that misrouting results in either Party's inability to bill or collect revenues from a third party and the Parties disagree as to the liability of the other Party for such revenues, then either Party may pursue the Dispute Resolution procedures set forth in this Agreement.
- 10.9.2 Records Exchange
- 10.9.2.1 Where feasible and appropriate, the Parties will generate and exchange all available messages for the purpose of billing third parties, including but not limited to CMRS providers and other LECs.

## **11. BASIC 911 AND E911 INTERCONNECTION**

- 11.1 Basic 911 and E911 provides a caller access to the applicable emergency service bureau by dialing 911.
- 11.2 Basic 911 Interconnection. BellSouth will provide to <<customer\_short\_name>> a list consisting of each municipality that subscribes to Basic 911 service. The list will also provide, if known, the E911 conversion date for each municipality and, for network routing purposes, a ten-digit directory number representing the appropriate emergency answering position for each municipality subscribing to 911. <<customer\_short\_name>> will be required to arrange to accept 911 calls from its end users in municipalities that subscribe to Basic 911 service and translate the 911 call to the appropriate 10-digit directory number as stated on the list provided by BellSouth. <<customer\_short\_name>> will be required to route the call to the appropriate PSAP. When a municipality converts to E911 service, <<customer\_short\_name>> will be required to begin using E911 procedures.
- 11.3 E911 Interconnection. <<customer\_short\_name>> shall install a minimum of two (2) dedicated trunks originating from its Serving Wire Center and terminating to the appropriate E911 tandem. The Serving Wire Center must be in the same LATA as the E911 tandem. The dedicated trunks shall be, at a minimum, DS0 level trunks configured as part of a digital (1.544 Mb/s) interface (DS1 facility). The configuration shall use CAMA-type signaling with multifrequency (MF) pulsing that will deliver ANI with the voice portion of the call. If the user interface is digital, MF pulses as well as other AC signals shall be encoded per the u-255 Law convention. <<customer\_short\_name>> will be required to provide BellSouth daily updates to the E911 database. <<customer\_short\_name>> will be

required to forward 911 calls to the appropriate E911 tandem along with ANI based upon the current E911 end office to tandem homing arrangement as provided by BellSouth. If the E911 tandem trunks are not available, <<customer\_short\_name>> will be required to route the call to a designated seven (7)-digit or ten (10)-digit local number residing in the appropriate PSAP. This call will be transported over BellSouth's interoffice network and will not carry the ANI of the calling party. <<customer\_short\_name>> shall be responsible for providing BellSouth with complete and accurate data for submission to the 911/E911 database for the purpose of providing 911/E911 to its End Users.

- 11.4** Rates. Recurring and nonrecurring rates associated with trunk groups for 911 service are as set forth in Section 3.3.1 of this Attachment.
- 11.5** The detailed practices and procedures for 911/E911 interconnection are contained in the E911 Local Exchange Carrier Guide For Facility-Based Providers, which can be found at <http://www.interconnection.bellsouth.com/guides/e911/html/gcuge001/index.htm>.

## **12. FRAME RELAY SERVICE INTERCONNECTION**

- 12.1.1** <<customer\_short\_name>> and BellSouth agree that, at the request of either Party, they will negotiate an amendment to this Agreement that provides rates, terms and conditions for frame relay service interconnection.

# Basic Architecture

Exhibit B

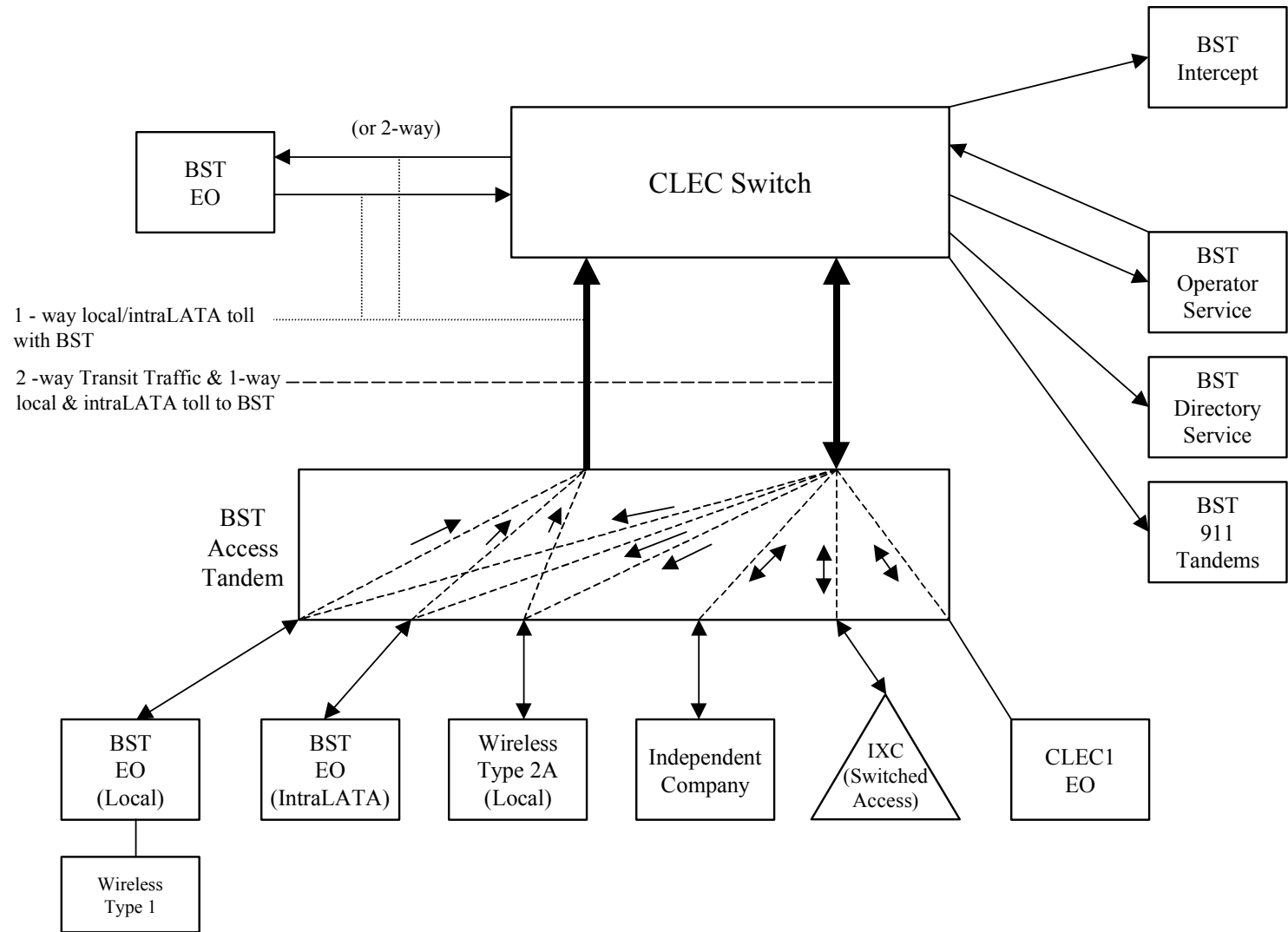

# One-Way Architecture

Exhibit C

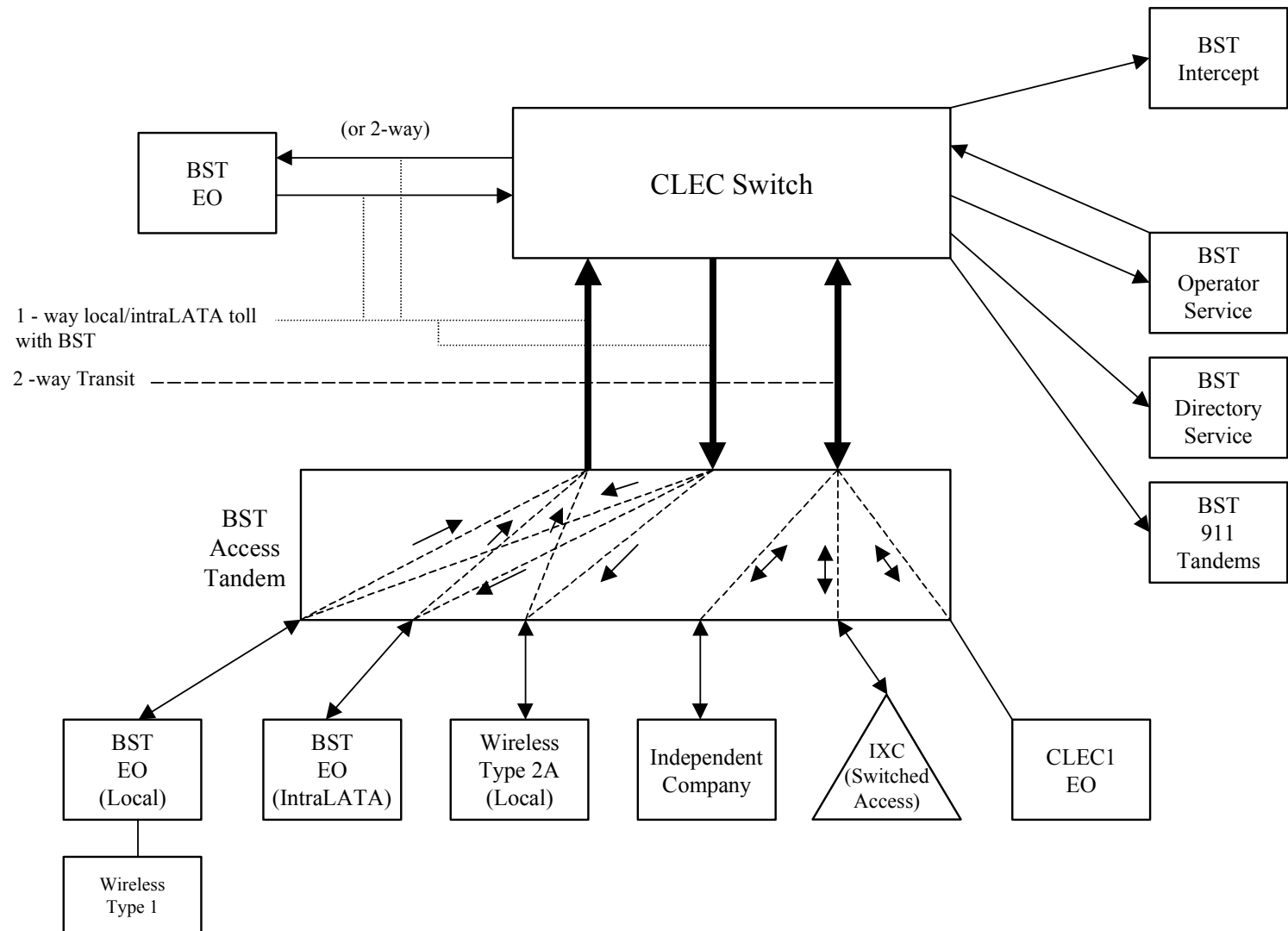

# Two-Way Architecture

Exhibit D

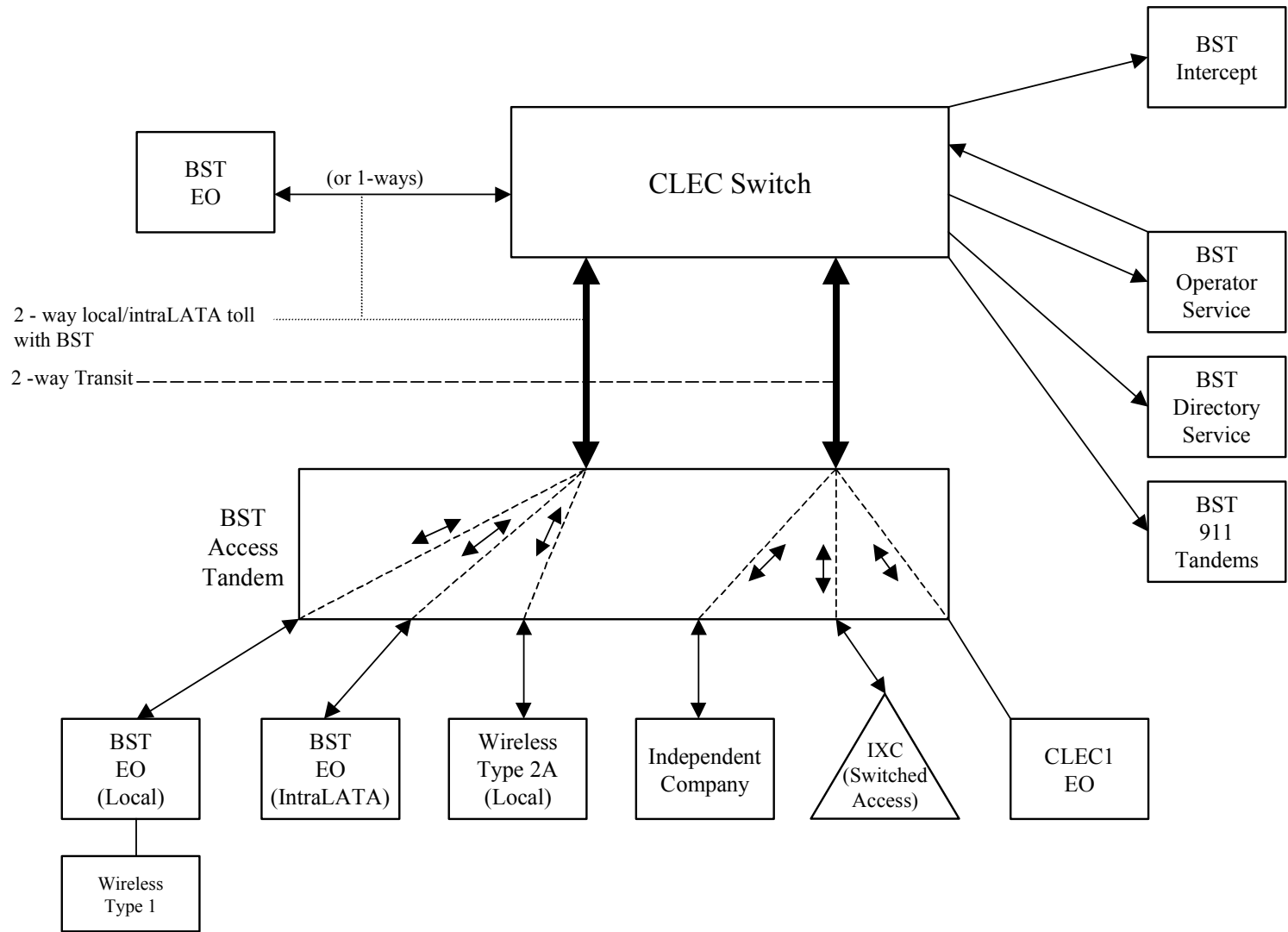

# Supergroup Architecture

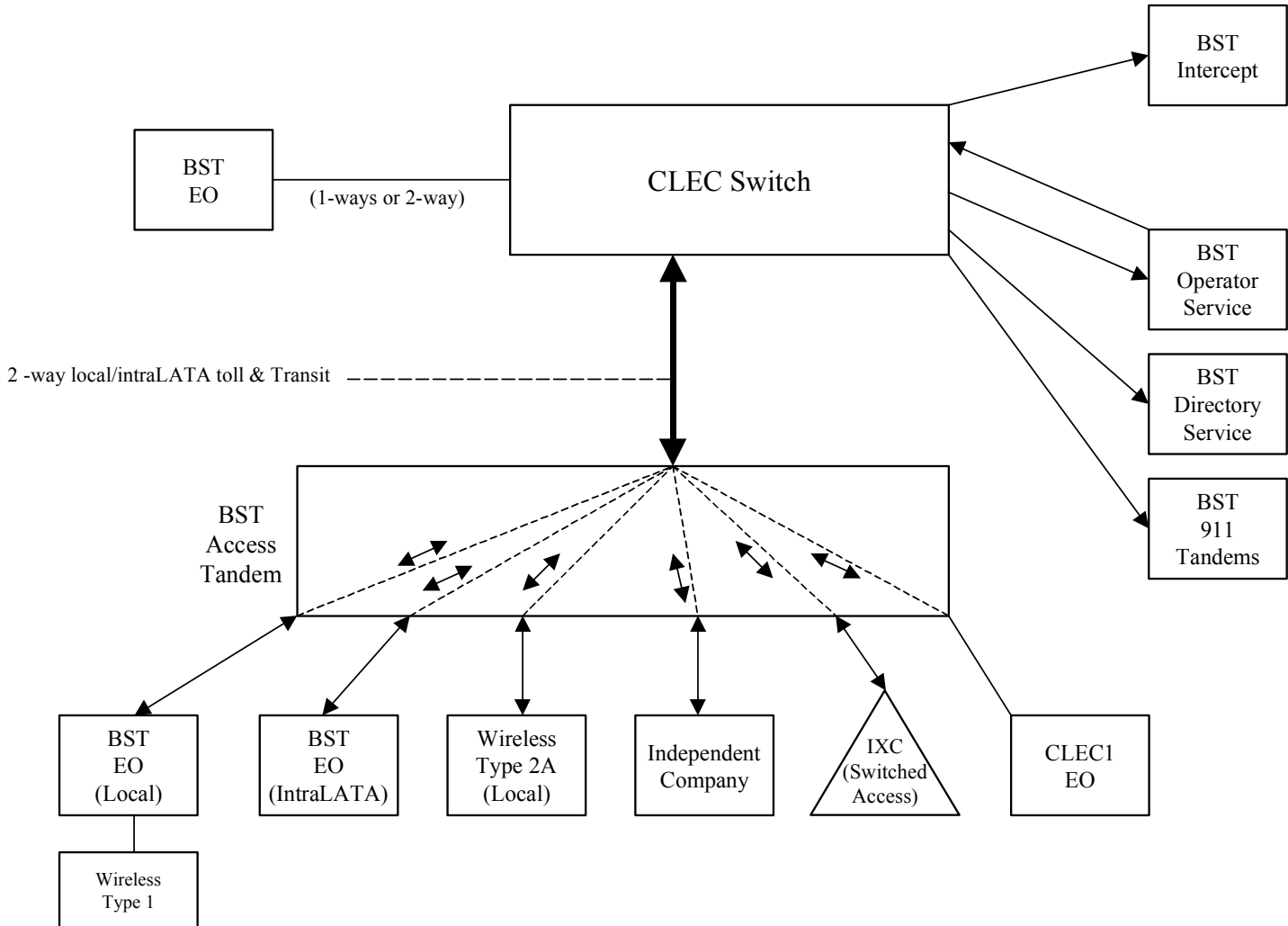

LOCAL INTERCONNECTION - Kentucky							Svc Order Submitted Elec per LSR	Svc Order Submitted Manually per LSR	Attachment: 3		Exhibit: A	
CATEGORY	RATE ELEMENTS	Interim	Zone	BCS	USOC	RATES (\$)			Incremental Charge - Manual Svc Order vs. Electronic-1st	Incremental Charge - Manual Svc Order vs. Electronic-Add'l	Incremental Charge - Manual Svc Order vs. Electronic-Disc 1st	Incremental Charge - Manual Svc Order vs. Electronic-Disc Add'l
						Rec	Nonrecurring		Nonrecurring Disconnect		OSS Rates (\$)	
							First	Add'l	First	Add'l	SOMEc	SOMAN
											SOMAN	SOMAN
<b>LOCAL INTERCONNECTION (CALL TRANSPORT AND TERMINATION)</b>												
NOTE: "bk" beside a rate indicates that the Parties have agreed to bill and keep for that element pursuant to the terms and conditions in Attachment 3.												
<b>TANDEM SWITCHING</b>												
	Tandem Switching Function Per MOU			OHD		0.0006772bk						
	Multiple Tandem Switching, per MOU (applies to initial tandem only)			OHD		0.0006772bk						
	Tandem Intermediary Charge, per MOU*			OHD		0.0025						
* This charge is applicable only to transit traffic and is applied in addition to applicable switching and/or interconnection charges.												
<b>TRUNK CHARGE</b>												
	Installation Trunk Side Service - per DS0			OHD	TPP6X		21.58bk		8.13bk			
	Installation Trunk Side Service - per DS0			OHD	TPP9X		21.58bk		8.13bk			
	Dedicated End Office Trunk Port Service-per DS0**			OHD	TDEOP	0.00bk						
	Dedicated End Office Trunk Port Service-per DS1**			OH1 OH1MS	TDE1P	0.00bk						
	Dedicated Tandem Trunk Port Service-per DS0**			OHD	TDWOP	0.00bk						
	Dedicated Tandem Trunk Port Service-per DS1**			OH1 OH1MS	TDW1P	0.00bk						
** This rate element is recovered on a per MOU basis and is included in the End Office Switching and Tandem Switching, per MOU rate elements												
<b>COMMON TRANSPORT (Shared)</b>												
	Common Transport - Per Mile, Per MOU			OHD		0.0000030bk						
	Common Transport - Facilities Termination Per MOU			OHD		0.0007466bk						
<b>LOCAL INTERCONNECTION (DEDICATED TRANSPORT)</b>												
<b>INTEROFFICE CHANNEL - DEDICATED TRANSPORT</b>												
	Interoffice Channel - Dedicated Transport - 2-Wire Voice Grade - Per Mile per month			OHM	1L5NF	0.01bk						
	Interoffice Channel - Dedicated Transport - 2-Wire Voice Grade - Facility Termination per month			OHM	1L5NF	29.11bk	47.34bk	31.78bk	22.77bk	8.75bk		
	Interoffice Channel - Dedicated Transport - 56 kbps - per mile per month			OHM	1L5NK	0.0115bk						
	Interoffice Channel - Dedicated Transport - 56 kbps - Facility Termination per month			OHM	1L5NK	20.97bk	47.35bk	31.78bk	22.77bk	8.75bk		
	Interoffice Channel - Dedicated Transport - 64 kbps - per mile per month			OHM	1L5NK	0.0115bk						
	Interoffice Channel - Dedicated Transport - 64 kbps - Facility Termination per month			OHM	1L5NK	20.97bk	47.35bk	31.78bk	22.77bk	8.75bk		
	Interoffice Channel - Dedicated Channel - DS1 - Per Mile per month			OH1, OH1MS	1L5NL	0.23bk						
	Interoffice Channel - Dedicated Transport - DS1 - Facility Termination per month			OH1, OH1MS	1L5NL	96.04bk	105.52bk	98.46bk	23.09bk	20.49bk		
	Interoffice Channel - Dedicated Transport - DS3 - Per Mile per month			OH3, OH3MS	1L5NM	4.97bk						
	Interoffice Channel - Dedicated Transport - DS3 - Facility Termination per month			OH3, OH3MS	1L5NM	1175.15bk	335.40bk	219.24bk	89.57bk	87.75bk		
<b>LOCAL CHANNEL - DEDICATED TRANSPORT</b>												
	Local Channel - Dedicated - 2-Wire Voice Grade per month			OHM	TEFV2	18.57bk	265.78bk	46.96bk	46.79bk	4.98bk		
	Local Channel - Dedicated - 4-Wire Voice Grade per month			OHM	TEFV4	19.86bk	266.48bk	47.65bk	47.54bk	5.73bk		
	Local Channel - Dedicated - DS1 per month			OH1	TEFHG	40.46bk	209.60bk	176.51bk	30.21bk	21.07bk		
	Local Channel - Dedicated - DS3 Facility Termination per month			OH3	TEFHJ	576.05bk	551.38bk	338.08bk	173.00bk	120.42bk		
<b>LOCAL INTERCONNECTION MID-SPAN MEET</b>												
NOTE: If Access service ride Mid-Span Meet, one-half the tariffed service Local Channel rate is applicable.												
	Local Channel - Dedicated - DS1 per month			OH1MS	TEFHG	0.00bk		0.00bk				
	Local Channel - Dedicated - DS3 per month			OH3MS	TEFHJ	0.00bk		0.00bk				
<b>MULTIPLEXERS</b>												
	Channelization - DS1 to DS0 Channel System			OH1, OH1MS	SATN1	113.33bk	101.40bk	71.60bk	13.79bk	13.04bk		
	DS3 to DS1 Channel System per month			OH3, OH3MS	SATNS	158.20bk	199.23bk	118.62bk	50.16bk	48.59bk		
	DS3 Interface Unit (DS1 COCI) per month			OH1, OH1MS	SATCO	11.80bk	10.07bk	7.08bk				

**Attachment 3**  
**Network Interconnection**



**TABLE OF CONTENTS**

<b>1. GENERAL.....</b>	<b>3</b>
<b>2. DEFINITIONS: (FOR THE PURPOSE OF THIS ATTACHMENT) .....</b>	<b>3</b>
<b>3. NETWORK INTERCONNECTION .....</b>	<b>5</b>
<b>4. INTERCONNECTION TRUNK GROUP ARCHITECTURES.....</b>	<b>9</b>
<b>5. NETWORK DESIGN AND MANAGEMENT FOR INTERCONNECTION .....</b>	<b>18</b>
<b>6. SIGNALING.....</b>	<b>51</b>
<b>7. FORECASTING FOR TRUNK PROVISIONING .....</b>	<b>28</b>
<b>8. TRUNK UTILIZATION .....</b>	<b>29</b>
<b>9. INTERFERENCE OR IMPAIRMENT .....</b>	<b>31</b>
<b>10. COMPENSATION FOR LOCAL TRAFFIC, ISP-BOUND TRAFFIC AND INTRALATA TOLL TRAFFIC.....</b>	<b>32</b>
<b>11. FRAME RELAY SERVICE INTERCONNECTION .....</b>	<b>43</b>

<b>Rates</b>	<b>Exhibit A</b>
<b>Basic Architecture</b>	<b>Exhibit B</b>
<b>One Way Architecture</b>	<b>Exhibit C</b>
<b>Two Way Architecture</b>	<b>Exhibit D</b>
<b>Supergroup Architecture</b>	<b>Exhibit E</b>

## NETWORK INTERCONNECTION

### 1. GENERAL

1.1 The Parties shall provide interconnection with each other's networks for the transmission and routing of telephone exchange service and exchange access on the following terms:

### 2. DEFINITIONS: (FOR THE PURPOSE OF THIS ATTACHMENT)

2.1 For purposes of this attachment only, the following terms shall have the definitions set forth below:

2.1.1 **Call Termination** has the meaning set forth for "termination" in 47 CFR § 51.701(d).

2.1.2 **Call Transport** has the meaning set forth for "transport" in 47 CFR § 51.701(c).

2.1.3 **Call Transport and Termination** is used collectively to mean the switching and transport functions from the Interconnection Point to the last point of switching consistent with FCC rules including but not limited to 47 CFR § 51.701 et seq.

2.1.4 **Common (Shared) Transport** is defined as the transport of the originating Party's traffic by the terminating Party over the terminating Party's common (shared) facilities between (1) the terminating Party's tandem switch and end office switch, (2) between the terminating Party's tandem switches, and/or (3) between the terminating Party's host and remote end office switches. All switches referred to herein must be registered in the Local Exchange Routing Guide (LERG).

2.1.5 **Cross Connect** is as defined in Attachment 4 of the Interconnection Agreement. If a Party provisions a cross connect for the purposes of interconnection under this Attachment 3, and such cross connect is not associated with a physical or virtual collocation arrangement, the provisioning party shall not charge for such cross connect.

2.1.6 **Dedicated Interoffice Facility** is defined as a switch transport facility between the <<customer\_short\_name>> Serving Wire Center (owned by BellSouth) and the first point of switching within the LATA on the BellSouth network or a switch transport facility between the BellSouth Serving Wire Center (owned by <<customer\_short\_name>>) and the first point of switching within the LATA on the <<customer\_short\_name>> network.

- 2.1.6 **End Office Switching** is defined as the function that establishes a communications path between the trunk side and line side of the End Office switch.
- 2.1.7 **Fiber Meet** is an interconnection arrangement whereby the Parties physically interconnect their networks via an optical fiber interface at which one Party's facilities, provisioning, and maintenance responsibility begins and the other Party's responsibility ends.
- 2.1.8 **Interconnection Point (IP)** is a physical telecommunications equipment interface that interconnects the networks of BellSouth and <<customer\_short\_name>>.
- 2.1.9 **IntraLATA Toll Traffic** is all traffic that originates and terminates within a single LATA that is not Local or ISP-bound traffic under this Attachment.
- 2.1.10 **ISP-Bound Traffic** is calls to an information service provider/enhanced service provider or Internet service provider (ISP) that are dialed by using a local dialing pattern (7 or 10 digits).
- 2.1.11 **Local Channel** is defined as a switched transport facility between a Party's Point of Presence and its designated Serving Wire Center where the Point of Presence is not located within the designated Serving Wire Center.
- 2.1.12 [Parties Disagree]
- [Xspedius Version] **Local Traffic** is defined as any telephone call that originates in one exchange and is terminated in either the same exchange, or other mandatory local calling area associated with the originating exchange (e.g., mandatory Extended Area Service) as defined and specified in Section A3 of BellSouth's General Subscriber Service Tariff. Designation of Local Traffic is not dependent on the type of switching technology used to switch and terminate such Local Traffic, including use of frame switching. Local Traffic includes any cross boundary, intrastate, interLATA or interstate, interLATA calls established as a local call by the ruling regulatory body.
- [BellSouth Version] **Local Traffic** is defined as any telephone call that originates in one exchange and terminates in either the same exchange, or other local calling area associated with the originating exchange as defined and specified in Section A3 of BellSouth's General Subscriber Service Tariff.

- 2.1.13 A **Point of Presence** is the physical location at which a Party establishes itself for obtaining access to the other Party's network.
- 2.1.14 **Reciprocal Trunk Group** is defined as a one-way trunk group carrying BellSouth originated traffic to be terminated by <<customer\_short\_name>>.
- 2.1.15 **Serving Wire Center** is defined as the wire center owned or leased by one Party from which the other Party would normally obtain dial tone for its Point of Presence.
- 2.1.7 **Tandem Switching** is defined as the function that establishes a communications path between two switching offices through a third switching office through the provision of trunk side to trunk side switching.
- 2.1.7.1 Consistent with FCC rules and orders, a <<customer\_short\_name>> switch shall be considered a tandem switch if it serves a geographic area comparable to that served by the relevant BellSouth tandem switch. <<customer\_short\_name>> shall provide to BellSouth supporting data to show such geographic comparability and if the Parties are unable to agree then the issue shall be resolved pursuant to the Dispute Resolution process set forth in the General Terms and Conditions of this Agreement.
- 2.1.8 **Transit Traffic** is traffic originating on one party's network that is switched and/or transported by the other Party and delivered to a third party's network, or traffic originating on a third party's network that is switched and/or transported by one party and delivered to the other Party's network.

### 3. NETWORK INTERCONNECTION

3.1 This Attachment pertains only to the provision of network interconnection where <<customer\_short\_name>> owns, leases from a third party or otherwise provides its own switch(es).

3.2 [Parties Disagree]

[Xspedius Version] Network interconnection may be provided by the Parties via any technically feasible method, **including but not limited to OCn level interconnection at TELRIC-compliant rates**, and at any technically feasible point or points in accordance with applicable FCC and Commission rules and orders.

[BellSouth Version] Network interconnection may be provided by the Parties via any technically feasible method and at any technically feasible point or points

**within BellSouth's network** in accordance with applicable FCC and Commission rules and orders.

- 3.2.1 Requests for interconnection at a point or points other than as set forth in this Attachment may be made through the Bona Fide Request (BFR) process set out in Attachment 11 to this Agreement. At such time that BellSouth submits a request for interconnection that meets the requirements of this section, the Parties will negotiate the rates, terms, and conditions for such request.
- 3.2.2 Each Party is responsible for providing, engineering and maintaining the network on its side of the IP. The IP must be located within BellSouth's serving territory in the LATA in which traffic is originating. The IP determines the point at which the originating Party shall pay the terminating Party for the Call Transport and Termination of Local Traffic, ISP-Bound Traffic and IntraLATA Toll Traffic.
- 3.2.3 Pursuant to the provisions of this Attachment, the Parties will endeavor in good faith to mutually agree on the location of the initial IP(s) in a given LATA.
- 3.2.4 Subject to the requirements for installing additional IPs, as set forth below, any IPs existing prior to the Effective Date of the Agreement will be accepted as initial IPs. BellSouth will not require re-grooming, however, <<customer\_short\_name>> may regroom and augment such IPs.
- 3.2.5 In selecting the initial IP(s), both Parties will act in good faith and shall consider points that are efficient for both Parties. If the Parties are unable to agree on the location of the initial IP, the Parties will establish the initial IP at the BellSouth access tandem in the LATA, or, where multiple BellSouth access tandems reside in such LATA, <<customer\_short\_name>> shall designate the BellSouth access tandem at which the Parties will establish the initial IP.
- 3.2.6 Additional IP(s) in a LATA may be established by mutual agreement of the Parties. In selecting additional IPs, both Parties will act in good faith and shall consider points that are efficient for both Parties. Unless mutually agreed otherwise or where direct end office trunking has been installed in accordance with Section 4.10.3.4.1. of this Attachment 3, an additional IP must be established if the following criteria are met: (1) the traffic between <<customer\_short\_name>> and BellSouth at the proposed additional IP must exceed a DS3, or 8.9 million minutes of Local Traffic and ISP-Bound Traffic, per month for three consecutive months; and (2) any end office to be designated as an IP must be more than 20 miles from an existing IP. BellSouth will not request the establishment of an IP where physical or virtual collocation space is not available or where BellSouth fiber connectivity is not available.
- 3.2.7 When the Parties agree to utilize two-way interconnection trunk groups for the exchange of Local Traffic, ISP-bound Traffic and IntraLATA Toll Traffic the Parties must agree to the location of the initial and/or additional IP(s).

- 3.2.8 Upon written notification from the Party requesting the establishment of an additional IP, the receiving Party has twenty (20) business days to analyze, respond to, and negotiate in good faith regarding the establishment of such IP. Should the Parties disagree on how to proceed, the requesting Party may resort to the Dispute Resolution process set forth in the General Terms and Conditions.

### 3.3 Interconnection via Dedicated Facilities

#### 3.3.1 [Parties Disagree]

**[Xspedius Version] Local Channel Facilities.** As part of Call Transport and Termination, either Party may purchase Local Channel facilities from the other Party pursuant to the provisions of this Attachment and at the rates set forth in Exhibit A.

**[BellSouth Version] Local Channel Facilities.** As part of Call Transport and Termination, either Party may purchase Local Channel facilities from the other Party pursuant to the provisions of this Attachment. . The percentage of Local Channel Facilities utilized for Local Traffic and ISP-bound Traffic shall be determined based upon the application of the Percent Local Facility (PLF) Factor on a statewide basis. The charges applied to the percentage of Local Channel facilities used for Local Traffic and ISP-bound Traffic as determined by the PLF are set forth in Exhibit A to this Attachment. The remaining percentage of Local Channel Facilities shall be billed at the appropriate Party's intrastate or interstate tariff rates for switched access services or reasonable and non-discriminatory web-posted listing if the FCC or Commission does not require filing of a tariff.

#### 3.3.2 [Parties Disagree]

**[Xspedius Version] Dedicated Interoffice Facilities.** As part of Call Transport and Termination, either Party may purchase Dedicated Interoffice facilities from the other Party pursuant to the provisions of this Attachment and at the rates set forth in Exhibit A.

**[BellSouth Version] Dedicated Interoffice Facilities.** As part of Call Transport and Termination, either Party may purchase Dedicated Interoffice facilities from the other Party pursuant to the provisions of this Attachment. The percentage of Dedicated Interoffice Facilities utilized for Local Traffic and ISP-bound Traffic shall be determined based upon the application of the Percent Local Facility (PLF) Factor on a statewide basis. The charges applied to the percentage of Dedicated Interoffice facilities used for Local Traffic and ISP-bound Traffic as determined by the PLF are set forth in Exhibit A to this Attachment. The remaining percentage of the Dedicated Interoffice Facilities shall be billed at the

appropriate Party's intrastate or interstate tariff rates for switched access services or reasonable and non-discriminatory web-posted listing if the FCC or Commission does not require filing of a tariff.

3.3.3 [Parties Disagree]

[Xspedius Version] In the event that a Party's Point of Presence is located within any serving wire center (i.e., switch location), such Party may interconnect to the other Party's switch via a Cross Connect or any other technically feasible means of interconnection.

[BellSouth Version] If a Party provisions a cross connect for the purposes of interconnection under this Attachment 3, and such cross connect is not associated with a physical or virtual collocation arrangement, the provisioning party shall not charge for such cross connect.

3.3.4 The facilities and associated components as set forth in Exhibit A of this Attachment purchased pursuant to this Section 3 shall be ordered via the Access Service Request (ASR) process. The terms, conditions and rates for ordering charges (i.e., expedite, cancellation, and order modification charges) are as set forth in the BellSouth FCC Tariff No. 1. To the extent that BellSouth requests that <<customer\_short\_name>> submit an ASR for an augmentation to the facilities purchased by <<customer\_short\_name>> from BellSouth but utilized for BellSouth's originated traffic, the Parties will work in good faith and make best efforts to ensure that the ASR submitted for such augmentations does not require expedition, cancellation or modification and in the event that <<customer\_short\_name>> incurs ordering charges, BellSouth and <<customer\_short\_name>> shall work cooperatively to determine which Party caused the incurrence of such charges and that Party shall be responsible for such charges.

3.4 **Fiber Meet**

3.4.1 If <<customer\_short\_name>> elects to establish interconnection with BellSouth pursuant to a Fiber Meet Local Channel, <<customer\_short\_name>> and BellSouth shall jointly engineer, operate and maintain a Synchronous Optical Network (SONET) transmission system by which they shall interconnect their transmission and routing of Local Traffic via a Local Channel at either the, DS10, DS1, or DS3 level. The Parties shall work jointly to determine the specific transmission system. However, <<customer\_short\_name>>'s SONET transmission system must be compatible with BellSouth's equipment, and the Data Communications Channel (DCC) must be turned off, unless otherwise mutually agreed to by the Parties.

- 3.4.2 Each Party, at its own expense, shall procure, install and maintain the agreed upon SONET transmission system in its network.
- 3.4.3 The Parties shall agree to a Fiber Meet point between the BellSouth Serving Wire Center and the <<customer\_short\_name>> Serving Wire Center. The Parties shall deliver their fiber optic facilities to the Fiber Meet point with sufficient spare length to reach the fusion splice point for the Fiber Meet Point. BellSouth shall, at its own expense, provide and maintain the fusion splice point for the Fiber Meet. A building type Common Language Location Identification (CLLI) code will be established for each Fiber Meet point. All orders for interconnection facilities from the Fiber Meet point shall indicate the Fiber Meet point as the originating point for the facility.
- 3.4.4 Upon verbal request by <<customer\_short\_name>> and within a reasonable and non-discriminatory timeframe, BellSouth shall allow <<customer\_short\_name>> access to the fusion splice point for the Fiber Meet point for maintenance purposes on <<customer\_short\_name>>'s side of the Fiber Meet point.
- 3.4.5 [Parties Disagree]

[Xspedius Version] Neither Party shall charge the other for its Local Channel portion of the Fiber Meet facility used for Local Traffic and ISP-bound Traffic.

[BellSouth Version] Neither Party shall charge the other for its Local Channel portion of the Fiber Meet facility used for Local Traffic and ISP-bound Traffic. The percentage of Dedicated Interoffice Facilities utilized for Local Traffic and ISP-bound Traffic shall be determined based upon the application of the Percent Local Facility (PLF) Factor on a statewide basis. The remaining percentage of the Local Channel shall be billed at the appropriate Party's intrastate or interstate tariff rates for switched access services or reasonable and non-discriminatory web-posted listing if the FCC or Commission does not require filing of a tariff.

#### 4. INTERCONNECTION TRUNK GROUP ARCHITECTURES

- 4.1 BellSouth and <<customer\_short\_name>> shall establish interconnecting trunk groups and trunk group configurations between networks, including the use of one-way or two-way trunks in accordance with the following provisions set forth in this Attachment. For trunking purposes, traffic will be routed based on the digits dialed by the originating End User and in accordance with the LERG.
- 4.2 <<customer\_short\_name>> shall establish an interconnection trunk group(s) to at least one BellSouth access tandem within the LATA for the delivery of <<customer\_short\_name>>'s originated Local Traffic, ISP-bound Traffic and IntraLATA Toll Traffic and for the receipt and delivery of Transit Traffic. To the extent <<customer\_short\_name>> desires to deliver Local Traffic, ISP-bound



Traffic, IntraLATA Toll Traffic and/or Transit Traffic to BellSouth access tandems within the LATA, other than the tandems(s) to which <<customer\_short\_name>> has established interconnection trunk groups, <<customer\_short\_name>> shall order Multiple Tandem Access, as described in this Attachment, to such other BellSouth access tandems.

4.2.1 Notwithstanding the forgoing, <<customer\_short\_name>> shall establish an interconnection trunk group(s) to all BellSouth access and local tandems in the LATA where <<customer\_short\_name>> has homed (i.e., assigned) its NPA/NXXs. <<customer\_short\_name>> shall home its NPA/NXXs on the BellSouth tandems that serve the exchange rate center areas to which the NPA/NXXs are assigned. The specified exchange rate center assigned to each BellSouth tandem is defined in the LERG. <<customer\_short\_name>> shall enter its NPA/NXX access and/or local tandem homing arrangements into the LERG.

4.3 Switched access traffic will be delivered to and from Interexchange Carriers (IXCs) based on <<customer\_short\_name>>'s NXX access tandem homing arrangement as specified by <<customer\_short\_name>> in the LERG.

4.4 Any <<customer\_short\_name>> interconnection request that (1) deviates from the interconnection trunk group architectures as described in this Agreement, (2) affects traffic delivered to <<customer\_short\_name>> from a BellSouth switch and (3) requires special BellSouth switch translations and other network modifications will require <<customer\_short\_name>> to follow the procedures set forth in Attachment 11 to this Agreement. At such time that BellSouth submits a request for interconnection that meets the requirements of this section, the Parties will negotiate the rates, terms, and conditions for such request.

4.5 [Parties Disagree]

[Xspedius Version] Recurring and nonrecurring rates associated with interconnecting trunk groups between BellSouth and <<customer\_short\_name>> are set forth in Exhibit A. To the extent a rate associated with the interconnecting trunk group is not set forth in Exhibit A, and no Commission approved rate has been set, the rate shall be negotiated by the Parties. If the Parties are unable to agree on a rate, either Party may Petition the Commission to establish a rate.

[BellSouth Version] Recurring and nonrecurring rates associated with interconnecting trunk groups between BellSouth and <<customer\_short\_name>> are set forth in Exhibit A. **To the extent a rate associated with the interconnecting trunk group is not set forth in Exhibit A, the rate shall be as set forth in the appropriate Party's intrastate or interstate tariff rates for switched access services or reasonable and non-discriminatory web-posted listing if the FCC or Commission does not require filing of a tariff.**

4.6 [Parties Disagree]

**[Xspedius Version]** For two-way trunk groups that carry only both Parties' non-transit and non-interLATA Switched Access traffic, each Party shall pay its proportionate share of the recurring charges for trunks and associated facilities and nonrecurring charges for additional trunks and associated facilities based on the percentage of the total traffic originated by that Party. The Parties shall determine the applicable percentages twice per year based on the previous six months minutes of use billed by each Party. Each Party shall pay its proportionate share of initial facilities based on the joint forecasts for circuits required by each Party. <<customer\_short\_name>> shall be responsible for ordering and paying for any two-way trunks carrying Transit Traffic.

**[BellSouth Version]** For two-way trunk groups that carry only both Parties' Local Traffic, the Parties shall be compensated at 50% of the nonrecurring and recurring rates for dedicated trunks and DS1 facilities.

<<customer\_short\_name>> shall be responsible for ordering and paying for any two-way trunks carrying Transit Traffic.

4.7 Unless the Parties mutually agree otherwise, <<customer\_short\_name>> shall be responsible for ordering and paying for any two way trunks carrying Transit Traffic. At such time as <<customer\_short\_name>> is providing the transit function for 15% or more of all Transit Traffic, <<customer\_short\_name>> will provide BellSouth with notification and supporting documentation that such threshold has been met. Within fifteen days following BellSouth's receipt of such notification and documentation, the Parties will begin negotiations for an alternative compensation arrangement for such two-way trunks carrying Transit Traffic. If the Parties are unable to agree to an alternative compensation arrangement within forty-five days of BellSouth's receipt of notification, then the Parties shall mutually agree to extend the negotiations or, absent mutual agreement, the Parties shall refer to the Dispute Resolution procedure set forth in this Agreement. Upon agreement of such alternative compensation arrangement, the Parties shall execute an amendment implementing such alternative compensation for two way trunks carrying Transit Traffic and the Parties shall "true-up" such arrangement to the date BellSouth received notification.

4.8 All trunk groups will be provisioned as Signaling System 7 (SS7) capable where technically feasible. If SS7 is not technically feasible, multi-frequency (MF) protocol signaling shall be used.

- 4.9** In cases where <<customer\_short\_name>> is also an IXC, the IXC's Feature Group D (FG D) trunk group(s) must remain separate from the local interconnection trunk group(s).
- 4.10** Each Party shall order interconnection trunks and trunk groups, including trunk and trunk group augmentations, via the ASR process. A Firm Order Confirmation (FOC) shall be returned to the ordering Party, after receipt of a valid, error free ASR, within the timeframes as set forth in Attachment 6, if applicable.. Notwithstanding the foregoing, blocking situations and projects shall be project managed through BellSouth's Carrier Interconnection Switching Center (CISC) Project Management Group and <<customer\_short\_name>>'s equivalent trunking group and FOCs for such orders shall be returned in the timeframes negotiated by the Parties and suitable to the project. No additional charges shall be triggered due to the involvement of such project management. A project is defined as (1) a new trunk group (excluding augments to existing routes) or (2) a request for more than 96 trunks on a single or multiple group(s) in a given BellSouth local calling area.
- 4.11** **Interconnection Trunk Groups for Exchange of Local Traffic, ISP-Bound Traffic, IntraLATA Toll Traffic and Transit Traffic**
- Upon mutual agreement of the Parties, the Parties' shall exchange Local Traffic, ISP-Bound Traffic, IntraLATA Toll and Transit Traffic, where applicable, on two-way interconnection trunk group(s) with the quantity of trunks being mutually determined and the provisioning being jointly coordinated. Furthermore, the Parties shall agree upon the IP(s) for two-way interconnection trunk groups transporting both Parties' Local Traffic, ISP-Bound Traffic and, IntraLATA Toll Traffic and Transit Traffic, where applicable, as set forth in Section 3 of this Attachment above. Upon determination by the Parties, in a joint planning meeting, that such trunk groups shall be utilized, <<customer\_short\_name>> shall order such two-way trunks via the Access Service Request (ASR) process. BellSouth will use the Trunk Group Service Request (TGSR) to request changes in trunking. Furthermore, the Parties shall jointly review trunk performance and forecasts on a periodic basis, as set forth in Section 7 of this Attachment. The Parties' use of two-way interconnection trunk groups for the transport of Local Traffic, ISP-Bound Traffic and, IntraLATA Toll Traffic and Transit Traffic, where applicable, between the Parties does not preclude the Parties from mutually agreeing to establish additional one-way interconnection trunks for the delivery of its originated Local Traffic, ISP-Bound Traffic and, IntraLATA Toll Traffic and Transit Traffic to the other Party, where necessary, however, the proposal to establish such one-ways will be discussed by the Parties prior to the submission of an ASR.
- 4.11.1** **BellSouth Access Tandem Interconnection**

Interconnection at a single access tandem provides access to those end offices subtending that access tandem (Intratandem Access). Access tandem interconnection is available for any of the following access tandem architectures.

#### 4.11.1.1 **Basic Architecture**

In the Basic Architecture, <<customer\_short\_name>>'s originating Local Traffic, ISP-bound Traffic and IntraLATA Toll Traffic and originating and terminating Transit Traffic is transported on a single two-way trunk group between <<customer\_short\_name>> and BellSouth access tandem(s) within a LATA to provide Intratandem Access. This trunk group carries Transit Traffic between <<customer\_short\_name>> and Independent Companies, Interexchange Carriers, other CLECs, and CMRS providers that have a Meet Point Billing arrangement with BellSouth, and other network providers with which <<customer\_short\_name>> desires to exchange traffic. This trunk group also carries <<customer\_short\_name>> originated Transit Traffic transiting a single BellSouth access tandem destined to third party tandems such as an Independent Company tandem or other CLEC tandem. BellSouth originated Local Traffic, ISP-bound Traffic and IntraLATA Toll Traffic is transported on a separate single one-way trunk group terminating to <<customer\_short\_name>>. Other trunk groups for operator services, directory assistance, and intercept may be established pursuant to the applicable BellSouth tariff if service is requested. The LERG shall be referenced for current routing and tandem serving arrangements. The Basic Architecture is illustrated in Exhibit B.

#### 4.11.1.2 **One-Way Trunk Group Architecture**

In One-Way Trunk Group architecture, the Parties interconnect using three separate trunk groups. A one-way trunk group provides Intratandem Access for <<customer\_short\_name>>-originated Local Traffic, ISP-bound Traffic and IntraLATA Toll Traffic destined for BellSouth End Users. A second one-way trunk group carries BellSouth-originated Local Traffic, ISP-bound Traffic and IntraLATA Toll Traffic destined for <<customer\_short\_name>> End-Users. A two-way trunk group provides Intratandem Access for <<customer\_short\_name>>'s originating and terminating Transit Traffic. This trunk group carries Transit Traffic between <<customer\_short\_name>> and Independent Companies, Interexchange Carriers, other CLECs, CMRS providers that have a Meet Point Billing arrangement with BellSouth, and other network providers with which <<customer\_short\_name>> desires to exchange traffic. This trunk group also carries <<customer\_short\_name>> originated Transit Traffic transiting a single BellSouth access tandem destined to third party tandems such as an Independent Company tandem or other CLEC tandem. BellSouth originated Local Traffic, ISP-bound Traffic and IntraLATA Toll Traffic is transported on a separate single one-way trunk group terminating to <<customer\_short\_name>>. Other trunk groups for operator services, directory assistance, and intercept may be established pursuant to the applicable BellSouth tariff if service is requested. The LERG contains current routing and tandem

serving arrangements. The one-way trunk group architecture is illustrated in Exhibit C.

#### 4.11.1.3 **Two-Way Trunk Group Architecture**

The Two-Way Trunk Group Architecture establishes one two-way trunk group to provide IntraTandem Access for the exchange of Local Traffic, ISP-bound Traffic and IntraLATA Toll Traffic between <<customer\_short\_name>> and BellSouth. In addition, a separate two-way transit trunk group must be established for <<customer\_short\_name>>'s originating and terminating Transit Traffic. This trunk group carries Transit Traffic between <<customer\_short\_name>> and Independent Companies, Interexchange Carriers, other CLECs, CMRS providers that have a Meet Point Billing arrangement with BellSouth, and other network providers with which <<customer\_short\_name>> desires to exchange traffic. This trunk group also carries <<customer\_short\_name>> originated Transit Traffic transiting a single BellSouth access tandem destined to third party tandems such as an Independent Company tandem or other CLEC tandem. Either Party's originated traffic, may, in order to prevent or remedy traffic blocking situations, be transported on a separate single one-way trunk group terminating to the other Party. Other trunk groups for operator services, directory assistance, and intercept may be established pursuant to the applicable BellSouth tariff if service is requested. The LERG contains current routing and tandem serving arrangements. The two-way trunk group architecture is illustrated in Exhibit D.

#### 4.11.1.4 **Supergroup Architecture**

In the Supergroup Architecture, the Parties' Local Traffic, ISP-bound Traffic and IntraLATA Toll Traffic and <<customer\_short\_name>>'s Transit Traffic are exchanged on a single two-way trunk group between <<customer\_short\_name>> and BellSouth to provide IntraTandem Access to <<customer\_short\_name>>. This trunk group carries Transit Traffic between <<customer\_short\_name>> and Independent Companies, Interexchange Carriers, other CLECs, CMRS providers that have a Meet Point Billing arrangement with BellSouth, and other network providers with which <<customer\_short\_name>> desires to exchange traffic. This trunk group also carries <<customer\_short\_name>> originated Transit Traffic transiting a single BellSouth access tandem destined to third party tandems such as an Independent Company tandem or other CLEC tandem. Either Party's originated traffic, may, in order to prevent or remedy a traffic blocking situations, be transported on a separate single one-way trunk group terminating to the other Party. Other trunk groups for operator services, directory assistance, and intercept may be established pursuant to the applicable BellSouth tariff if service is requested. The LERG shall be referenced for current routing and tandem serving arrangements. The Supergroup architecture is illustrated in Exhibit E.

#### 4.11.1.5 **Multiple Tandem Access Interconnection**

- 4.11.1.5.1 BellSouth Multiple Tandem Access (“MTA”) provides for LATA wide BellSouth transport and termination of <<customer\_short\_name>>’s-originated local, ISP-bound and intraLATA toll traffic transported by BellSouth by establishing an interconnection trunk group at a BellSouth access tandem with routing through multiple BellSouth access tandems as required. <<customer\_short\_name>> must also establish an interconnection trunk group(s) at all BellSouth access tandems where <<customer\_short\_name>> NXXs are homed as described in Section 4.2.1 above. If <<customer\_short\_name>> does not have NXXs homed at any particular BellSouth access tandem within a LATA and elects not to establish an interconnection trunk group(s) at such BellSouth access tandem, <<customer\_short\_name>> can order MTA in each BellSouth access tandem within the LATA where it does have an interconnection trunk group(s) and BellSouth will terminate <<customer\_short\_name>>’s Local Traffic, ISP-bound Traffic and IntraLATA Toll Traffic to End-Users served through those BellSouth access tandems where <<customer\_short\_name>> does not have an interconnection trunk group(s).
- 4.11.1.5.2 <<customer\_short\_name>> may also utilize MTA to route its originated Transit Traffic; provided, however, that MTA may not be utilized to route switched access traffic that transits the BellSouth network to an Interexchange Carrier (IXC). Switched access traffic originated by or terminated to <<customer\_short\_name>> will be delivered to and from IXCs based on <<customer\_short\_name>>’s NXX access tandem homing arrangement as specified by <<customer\_short\_name>> in the LERG.
- 4.11.1.5.3 Compensation for MTA shall be at the applicable tandem switching and transport charges specified in Exhibit A to this Attachment and shall be billed in addition to other applicable Call Transport and Termination charges. The Multiple Tandem Access rate element set forth in Exhibit A applies to the initial tandem only.
- 4.11.1.5.4 To the extent <<customer\_short\_name>> does not purchase MTA in a LATA served by multiple access tandems, <<customer\_short\_name>> must establish an interconnection trunk group(s) to every access tandem in the LATA to serve the entire LATA. To the extent <<customer\_short\_name>> routes its traffic in such a way that utilizes BellSouth’s MTA service without properly ordering MTA, <<customer\_short\_name>> shall pay BellSouth the associated MTA charges. In a situation of tandem exhaust at any particular tandem, where the Parties choose MTA as an alternative routing plan, the Parties will negotiate appropriate rates, terms and conditions for MTA.
- 4.11.2 **Local Tandem Interconnection**
- 4.11.2.1 Local Tandem Interconnection arrangement allows <<customer\_short\_name>> to establish an interconnection trunk group(s) at BellSouth local tandems for: (1) the delivery of <<customer\_short\_name>>-originated Local Traffic, ISP-bound Traffic and IntraLATA Toll Traffic transported and terminated by BellSouth to

BellSouth end offices served by those BellSouth local tandems, and (2) for local Transit Traffic transported by BellSouth for third party network providers who have also established an interconnection trunk group(s) at those BellSouth local tandems.

- 4.11.2.2 When a specified local calling area is served by more than one BellSouth local tandem, <<customer\_short\_name>> must designate a “home” local tandem for each of its assigned NPA/NXXs and establish trunk connections to such local tandems. Additionally, <<customer\_short\_name>> may choose to establish an interconnection trunk group(s) at the BellSouth local tandems where it has no codes homing but is not required to do so. <<customer\_short\_name>> may deliver Local Traffic, ISP-bound Traffic and IntraLATA Toll Traffic to a “home” BellSouth local tandem that is destined for other BellSouth or third party network provider end offices subtending other BellSouth local tandems in the same local calling area where <<customer\_short\_name>> does not choose to establish an interconnection trunk group(s). It is <<customer\_short\_name>>’s responsibility to enter its own NPA/NXX local tandem homing arrangements into the LERG either directly or via a vendor in order for other third party network providers to determine appropriate traffic routing to <<customer\_short\_name>>’s codes. Likewise, <<customer\_short\_name>> shall obtain its routing information from the LERG.
- 4.11.2.3 Notwithstanding establishing an interconnection trunk group(s) to BellSouth’s local tandems, <<customer\_short\_name>> must also establish an interconnection trunk group(s) to BellSouth access tandems within the LATA on which <<customer\_short\_name>> has NPA/NXXs homed for the delivery of Interexchange Carrier Switched Access (SWA) and toll traffic and traffic to Type 2A CMRS connections located at the access tandems. BellSouth shall not switch SWA traffic through more than one BellSouth access tandem. SWA, Type 2A CMRS or toll traffic routed to the local tandem in error will not be backhauled to the BellSouth access tandem for completion. A Type 2A CMRS interconnection is a connection between a BellSouth access tandem or local tandem office to an Mobile Service Provider’s point of termination.
- 4.11.3 **Direct End Office-to-End Office Interconnection**
- 4.11.3.1 Direct End Office-to-End Office one-way or two-way interconnection trunk groups allow for the delivery of a Party’s originating Local Traffic, ISP-bound Traffic and IntraLATA Toll Traffic to the terminating Party on a direct end office-to-end office basis.
- 4.11.3.2 To the extent technically feasible and where appropriate, BellSouth will provide overflow routing consistent with how BellSouth overflows its traffic. The overflow will be based on the homing arrangements displayed in the LERG.

- 4.11.3.3 The Parties shall utilize direct end office-to-end office trunk groups under any one of the following conditions:
- 4.11.3.4 Tandem Exhaust - If a tandem through which the Parties are interconnected is unable to, or is forecasted to be unable to support additional traffic loads for the Parties or any other carrier for any period of time, the Parties will attempt to mutually agree on an end office trunking plan or an appropriate alternative routing plan that will alleviate the tandem capacity shortage and ensure completion of traffic between <<customer\_short\_name>> and BellSouth. (BST proposal)
- 4.11.3.5 Traffic Volume –To the extent either Party has the capability to measure the amount of traffic between <<customer\_short\_name>>'s ~~switch~~ switch and the BellSouth switch and where such traffic exceeds or is forecasted to exceed one DS3, or 8.9 million minutes of use, over a period of three consecutive months, then the Parties shall install and maintain direct end office trunking sufficient to handle such traffic volumes between a <<customer\_short\_name>> switch and a BellSouth switch. Either Party will install and maintain additional capacity between such points when overflow traffic exceeds or is forecasted to exceed one DS3, or 8.9 million minutes of use, of traffic per month. In the case of one-way trunking, additional trunking shall only be required by the Party whose trunking has achieved the preceding usage threshold.
- 4.11.3.5.1 Mutual Agreement - The Parties may install and maintain direct end office trunking upon mutual agreement in the absence of conditions (1) or (2) above.
- 4.11.4 **Transit Traffic Trunk Group**
- Transit Traffic trunks can either be two-way trunks or two one-way trunks ordered by <<customer\_short\_name>> to deliver and receive Transit Traffic. Establishing Transit Traffic trunks at BellSouth access and local tandems provides intratandem access to the third parties also interconnected at those tandems.
- 4.11.5 **Toll Free Traffic**
- 4.11.5.1 If <<customer\_short\_name>> chooses BellSouth to perform the Service Switching Point (SSP) Function (i.e., handle Toll Free database queries) from BellSouth's switches, all <<customer\_short\_name>> originating Toll Free traffic will be routed over the Transit Traffic Trunk Group and shall be delivered using GR-394 format. Carrier Code "0110" and Circuit Code (to be determined for each LATA) shall be used for all such calls.
- 4.11.5.2 <<customer\_short\_name>> may choose to perform its own Toll Free database queries from its switch. In such cases, <<customer\_short\_name>> will determine the nature (local/intraLATA/interLATA) of the Toll Free call (local/IntraLATA/InterLATA) based on the response from the database. If the response from the database determines that the call is a BellSouth local or



intraLATA Toll Free call, <<customer\_short\_name>> will route the post-query local or IntraLATA converted ten-digit local number to BellSouth over the local or intraLATA trunk group. If the response from the database determines that the is a third party (ICO, IXC, CMRS or other CLEC) local or intraLATA Toll Free call, <<customer\_short\_name>> will route the post-query local or intraLATA converted ten-digit local number to BellSouth over the Transit Traffic Trunk Group and <<customer\_short\_name>> shall provide to BellSouth a Toll Free billing record when appropriate. If the query reveals the call is an interLATA Toll Free call, <<customer\_short\_name>> will route the post-query interLATA Toll Free call (1) directly from its switch for carriers interconnected with its network or (2) over the Transit Traffic Trunk Group to carriers that are not directly connected to <<customer\_short\_name>>'s network but that are connected to BellSouth's access tandem.

4.11.5.3 All post-query Toll Free calls for which <<customer\_short\_name>> performs the SSP function, if delivered to BellSouth, shall be delivered using GR-394 format for calls destined to IXCs, and GR-317 format for calls destined to end offices that directly subtend a BellSouth access tandem within the LATA.

#### 4.11.5.4 **High Volume Calling (Mass Calling) Trunk Groups**

4.11.5.4.1 The Parties will cooperate to establish separate trunk groups, or provide some other means of protective controls (i.e., call gapping), for the completion of calls to high volume customers, such as radio contest lines.

4.11.5.4.2 Both parties agree to terminate each Party's mass calling codes as Local Traffic, where appropriate. The Parties agree that each will put in place controls for NXXs that are dedicated for media stimulated mass calling.

## 5. **NETWORK DESIGN AND MANAGEMENT FOR INTERCONNECTION**

5.1 **Network Management and Changes.** Both Parties will work cooperatively with each other to install and maintain the most effective and reliable interconnected telecommunications networks, including but not limited to, the exchange of toll-free maintenance contact numbers and escalation procedures. Both Parties agree to provide public notice of changes in the information necessary for the transmission and routing of services using their local exchange facilities or networks, as well as of any other changes that would affect the interoperability of those facilities and networks, to the extent required by, and in accordance with, applicable federal and state rules and regulations, and as otherwise provided in this Agreement.

5.2 **Interconnection Technical Standards.** The interconnection of all networks will be based upon accepted industry/national guidelines for transmission standards and traffic blocking criteria. Interconnecting facilities shall conform, at a minimum,

to the telecommunications industry standard of DS-1 pursuant to Telcordia Standard No. TR-NWT-00499. Where <<customer\_short\_name>> chooses to utilize Signaling System 7 signaling, also known as Common Channel Signaling (SS7), SS7 connectivity is required between the <<customer\_short\_name>> switch and the BellSouth Signaling Transfer Point (STP). BellSouth will provide SS7 signaling using Common Channel Signaling Access Capability in accordance with the technical specifications set forth in the BellSouth Guidelines to Technical Publication, TR-TSV-000905. Facilities of each Party shall provide the necessary on-hook, off-hook answer and disconnect supervision and shall provide calling number ID (Calling Party Number) when technically feasible.

**5.3** Quality of Interconnection. The local interconnection for the transmission and routing of telephone exchange service and exchange access that each Party provides to each other will be at least Equal in Quality to what it provides to itself and any subsidiary or affiliate, where technically feasible, or to any other Party to which each Party provides local interconnection “Equal in Quality” shall have the meaning accorded in Section 51.305(a)(3) of the FCC’s Rules, 47 C.F.R. § 51.305(a)(3).

**5.4** Network Management Controls. Both Parties will work cooperatively to apply sound network management principles by invoking appropriate network management controls (e.g., call gapping) to alleviate or prevent network congestion.

## **6 Signaling**

6.1 BellSouth shall offer access to signaling and access to BellSouth’s signaling databases subject to compatibility testing and at the rates set forth in this Attachment. BellSouth may provide mediated access to BellSouth signaling systems and databases. Available signaling elements include signaling links, signal transfer points and service control points. Signaling functionality will be available with both A-link and B-link connectivity.

6.2 Signaling Link Transport

6.2.1 Signaling Link Transport is a set of two (2) or four (4) dedicated 56 kbps transmission paths between <<customer\_short\_name>> designated Signaling Points of Interconnection that provide appropriate physical diversity.

6.2.2 Technical Requirements

6.2.3 Signaling Link Transport shall consist of full duplex mode 56 kbps transmission paths and shall perform in the following two ways:

- 6.2.3.1 An “A-link” Signaling Link Transport is a connection between a switch or SCP and a Signaling Transfer Point switch pair; and
- 6.2.3.2 As a “B-link” Signaling Link Transport is a connection between two Signaling Transfer Point switch pairs in different company networks (e.g., between two Signaling Transfer Point switch pairs for two CLECs).
- 6.2.4 Signaling Link Transport shall consist of signaling link layers as follows:
  - 6.2.4.1 An A-link layer shall consist of two (2) links. There shall be no more than two (2) minutes down time per year for an A-link layer.
  - 6.2.4.2 A B-link layer shall consist of four (4) links. There shall be negligible (less than two (2) seconds) down time per year for a B-link layer.
- 6.2.5 A signaling link layer shall satisfy interoffice and intraoffice diversity of facilities and equipment, such that:
  - 6.2.5.1 No single failure of facilities or equipment causes the failure of both links in an A-link layer (i.e., the links should be provided on a minimum of two (2) separate physical paths end-to-end); and
  - 6.2.5.2 No two (2) concurrent failures of facilities or equipment shall cause the failure of all four (4) links in a B-link layer (i.e., the links should be provided on a minimum of three (3) separate physical paths end-to-end).
- 6.2.6 Interface Requirements
  - 6.2.6.1 There shall be a DS1 (1.544 Mbps) interface at <<customer\_short\_name>>’s designated SPOIs. Each 56 kbps transmission path shall appear as a DS0 channel within the DS1 interface.
- 6.3 Signaling Transfer Points (STPs)
  - 6.3.1 A Signaling Transfer Point is a signaling network function that includes all of the capabilities provided by the signaling transfer point switches (STPs) and their associated signaling links that enables the exchange of SS7 messages among and between switching elements, database elements and STPs.
  - 6.3.2 Technical Requirements
    - 6.3.2.1 STPs shall provide access to BellSouth Local Switching or Tandem Switching and to BellSouth Service Control Points/Databases connected to BellSouth SS7 network. STPs also provide access to third-party local or tandem switching and third-party-provided STPs.

- 6.3.2.2 The connectivity provided by STPs shall fully support the functions of all other Network Elements connected to the BellSouth SS7 network. This includes the use of the BellSouth SS7 network to convey messages that neither originate nor terminate at a signaling end point directly connected to the BellSouth SS7 network (i.e., transit messages). When the BellSouth SS7 network is used to convey transit messages, there shall be no alteration of the Integrated Services Digital Network User Part or Transaction Capabilities Application Part (TCAP) user data that constitutes the content of the message.
- 6.3.2.3 STPs shall provide all functions of the SCCP necessary for Class 0 (basic connectionless) service, as defined in Telcordia ANSI Interconnection Requirements. This includes Global Title Translation (GTT) and SCCP Management procedures, as specified in ANSI T1.112.4. Where the destination signaling point is a <<customer\_short\_name>> or third party local or tandem switching system directly connected to BellSouth SS7 network, BellSouth shall perform final GTT of messages to the destination and SCCP Subsystem Management of the destination. In all other cases, BellSouth shall perform intermediate GTT of messages to a gateway pair of STPs in an SS7 network connected with the BellSouth SS7 network, and shall not perform SCCP Subsystem Management of the destination. If BellSouth performs final GTT to a <<customer\_short\_name>> database, then <<customer\_short\_name>> agrees to provide BellSouth with the Destination Point Code for <<customer\_short\_name>> database.
- 6.3.2.4 STPs shall provide all functions of the Operations, Maintenance and Administration Part (OMAP) as specified in applicable industry standard technical references, which may include, where available in BellSouth's network, MTP Routing Verification Test (MRVT); and SCCP Routing Verification Test (SRVT).
- 6.3.2.5 Where the destination signaling point is a BellSouth local or tandem switching system or database, or is a <<customer\_short\_name>> or third party local or tandem switching system directly connected to the BellSouth SS7 network, STPs shall perform MRVT and SRVT to the destination signaling point. In all other cases, STPs shall perform MRVT and SRVT to a gateway pair of STPs in an SS7 network connected with the BellSouth SS7 network. This requirement may be superseded by the specifications for Internetwork MRVT and SRVT when these become approved ANSI standards and available capabilities of BellSouth STPs.
- 6.4 SS7 Advanced Intelligent Network (AIN) Access
- 6.4.1 Interface Requirements
- 6.4.1.1 BellSouth shall provide the following STP options to connect <<customer\_short\_name>> or <<customer\_short\_name>>-designated local switching systems to the BellSouth SS7 network:

- 6.4.1.1.1 An A-link interface from <<customer\_short\_name>> local switching systems;  
and,
- 6.4.1.1.2 A B-link interface from <<customer\_short\_name>> local STPs.
- 6.4.1.2 Each type of interface shall be provided by one or more layers of signaling links.
- 6.4.1.3 The Signaling Point of Interconnection for each link shall be located at a cross connect element in the central office where the BellSouth STP is located.
- 6.4.1.4 BellSouth shall provide intraoffice diversity between the SPOI and BellSouth STPs, so that no single failure of intraoffice facilities or equipment shall cause the failure of both B-links in a layer connecting to a BellSouth STP.
- 6.4.1.5 STPs shall provide all functions of the MTP as defined in the applicable industry standard technical references.
- 6.4.2 Message Screening
  - 6.4.2.1 BellSouth shall set message screening parameters so as to accept/send valid messages from <<customer\_short\_name>> local or tandem switching systems destined to/from any signaling point within BellSouth's SS7 network where the <<customer\_short\_name>> switching system has a valid signaling relationship.
- 6.4.3 BellSouth shall set message screening parameters so as to accept/send valid messages from <<customer\_short\_name>> local or tandem switching systems destined to/from any signalling point or network accessed through BellSouth's SS7 network where the <<customer\_short\_name>> switching system has a valid signalling relationship.
- 6.5 Service Control Points/Databases
  - 6.5.1 Call Related Databases provide the storage of, access to, and manipulation of information required to offer a particular service and/or capability. BellSouth shall provide access to the following Databases: Local Number Portability, LIDB, Toll Free Number Database, Automatic Location Identification/Data Management System, and Calling Name Database. BellSouth also provides access to Service Creation Environment and Service Management System (SCE/SMS) application databases and Directory Assistance.
  - 6.5.2 A Service Control Point (SCP) is deployed in a SS7 network that executes service application logic in response to SS7 queries sent to it by a switching system also connected to the SS7 network. Service Management Systems provide operational interfaces to allow for provisioning, administration and maintenance of subscriber data and service application data stored in SCPs.

- 6.5.3 Technical Requirements for SCPs/Databases
  - 6.5.3.1 BellSouth shall provide physical access to SCPs through the SS7 network and protocols with TCAP as the application layer protocol.
  - 6.5.3.2 BellSouth shall provide physical interconnection to databases via industry standard interfaces and protocols (e.g. SS7, ISDN and X.25).
  - 6.5.3.3 The reliability of interconnection options shall be consistent with requirements for diversity and survivability.
- 6.6 Local Number Portability Database
  - 6.6.1 The Permanent Number Portability (PNP) database supplies routing numbers for calls involving numbers that have been ported from one local service provider to another. BellSouth agrees to provide access to the PNP database at rates, terms and conditions as set forth by BellSouth and in accordance with an effective FCC or Commission directive.
- 6.7 SS7 Network Interconnection
  - 6.7.1 SS7 Network Interconnection is the interconnection of <<customer\_short\_name>> local STPs or <<customer\_short\_name>> local or tandem switching systems with BellSouth STPs. This interconnection provides connectivity that enables the exchange of SS7 messages among BellSouth switching systems and databases, <<customer\_short\_name>> local or tandem switching systems, and other third-party switching systems directly connected to the BellSouth SS7 network.
  - 6.7.2 The connectivity provided by SS7 Network Interconnection shall fully support the functions of BellSouth switching systems and databases and <<customer\_short\_name>> or other third-party switching systems with A-link access to the BellSouth SS7 network.
  - 6.7.3 If traffic is routed based on dialed or translated digits between a <<customer\_short\_name>> local switching system and a BellSouth or other third-party local switching system, either directly or via a BellSouth tandem switching system, then it is a requirement that the BellSouth SS7 network convey via SS7 Network Interconnection the TCAP messages that are necessary to provide Call Management services (Automatic Callback, Automatic Recall, and Screening List Editing) between the <<customer\_short\_name>> local STPs and BellSouth or other third-party local switch.
  - 6.7.4 SS7 Network Interconnection shall provide:

- 6.7.4.1 Signaling Data Link functions, as specified in ANSI T1.111.2;
- 6.7.4.2 Signaling Link functions, as specified in ANSI T1.111.3; and
- 6.7.4.3 Signaling Network Management functions, as specified in ANSI T1.111.4.
- 6.7.5 SS7 Network Interconnection shall provide all functions of the SCCP necessary for Class 0 (basic connectionless) service, as specified in ANSI T1.112. This includes GTT and SCCP Management procedures, as specified in ANSI T1.112.4. Where the destination signaling point is a BellSouth switching system or database, or is another third-party local or tandem switching system directly connected to the BellSouth SS7 network, SS7 Network Interconnection shall include final GTT of messages to the destination and SCCP Subsystem Management of the destination. Where the destination signaling point is a <<customer\_short\_name>> local or tandem switching system, SS7 Network Interconnection shall include intermediate GTT of messages to a gateway pair of <<customer\_short\_name>> local STPs, and shall not include SCCP Subsystem Management of the destination.
- 6.7.6 SS7 Network Interconnection shall provide all functions of the Integrated Services Digital Network User Part, as specified in ANSI T1.113.
- 6.7.7 SS7 Network Interconnection shall provide all functions of the TCAP, as specified in ANSI T1.114.
- 6.7.8 If Internetwork MRVT and SRVT become approved ANSI standards and available capabilities of BellSouth STPs, SS7 Network Interconnection may provide these functions of the OMAP.
- 6.7.9 Interface Requirements
  - 6.7.9.1 The following SS7 Network Interconnection interface options are available to connect <<customer\_short\_name>> or <<customer\_short\_name>>-designated local or tandem switching systems or STPs to the BellSouth SS7 network:
    - 6.7.9.1.1 A-link interface from <<customer\_short\_name>> local or tandem switching systems; and
    - 6.7.9.1.2 B-link interface from <<customer\_short\_name>> STPs.
  - 6.7.9.2 The SPOI for each link shall be located at a cross-connect element in the central office where the BellSouth STP is located. There shall be a DS1 or higher rate transport interface at each of the SPOIs. Each signaling link shall appear as a DS0 channel within the DS1 or higher rate interface.

6.7.9.3 BellSouth shall provide intraoffice diversity between the SPOIs and the BellSouth STP, so that no single failure of intraoffice facilities or equipment shall cause the failure of both B-links in a layer connecting to a BellSouth STP.

6.7.9.4 The protocol interface requirements for SS7 Network Interconnection include the MTP, ISDNUP, SCCP, and TCAP. These protocol interfaces shall conform to the applicable industry standard technical references. BellSouth does not have the capability to support any of the VoIP interfaces at the present time but is willing to negotiate new protocol interfaces.

6.7.9.5 BellSouth shall set message screening parameters to accept messages from <<customer\_short\_name>> local or tandem switching systems destined to any signaling point in the BellSouth SS7 network with which the <<customer\_short\_name>> switching system has a valid signaling relationship.

## 6.8 Rate Categories And Applications

### 6.8.1 Message Charges

6.8.1.1 Message charges, as set forth in 6.8.1.3, following, are assessed based on the type of message protocol, ISUP or TCAP. ISUP messages are associated with call set-up, while TCAP messages are used to query call related databases. ISUP message charges are assessed per terminating and originating call set-up request and TCAP message charges are assessed per data request.

6.8.1.2 Message charges do not apply for TCAP messages switched by the regional STPs to the BellSouth provided 800 Data Base, LIDB or LNP Data Base. Query charges are assessed in lieu of message charges. Query charges for 800 Data Base are described in 6.9.5, following. When TCAP messages are destined for a foreign database, including a non-company provided LNP Data Base, message charges are assessed in lieu of query charges.

6.8.1.3 Message charges are assessed in the following manner:

#### 6.8.1.3.1 Signal Formulation

6.8.1.3.1.1 An ISUP Signal Formulation charge is assessed, per call set-up request, for terminating and originating formulating signaling messages in association with call set-up.

#### 6.8.1.3.2 Signal Transport

6.8.1.3.2.1 An ISUP Signal Transport charge is assessed, per call set-up request, for signaling messages transported to and from the Company STP in association with call set-up.



- 6.8.1.3.2.2 A TCAP Signal Transport charge is assessed per data request transported to a BellSouth STP and destined for a foreign database.
- 6.8.1.3.3 Signal Switching
  - 6.8.1.3.3.1 An ISUP Signal Switching charge is assessed per call set-up request that is switched at the Company STP for terminating and originating messages .
  - 6.8.1.3.3.2 A TCAP Signal Switching charge is assessed for each data request that is switched by the Company STP and destined for a foreign network or database.
- 6.8.1.3.4 Query Charges
  - 6.8.1.3.4.1 Query charges apply for queries to the Company LIDB and the LNP Data Base. When query charges apply for access to a Company provided database, message charges are not assessed. LIDB Query Charges are described in 6.9.3, following and the LNP Data Base Query Charge is described in 6.9.4, following.
- 6.8.1.4 TCAP Bill and Keep
  - 6.8.1.4.1 The Parties agree to treat signaling messages, signaling ports, and signaling links associated with local calls on a bill and keep basis.
  - 6.8.1.4.2 <<customer\_short\_name>> and BellSouth agree that BellSouth will bill <<customer\_short\_name>> for signaling links, signaling ports, and signaling messages associated with interstate calls and with intrastate non-local calls in accordance with BellSouth's federal and state tariffs.
  - 6.8.1.4.3 Beginning on the Effective Date of this Agreement and continuing until <<customer\_short\_name>> implements a system that is capable of counting the total number of signaling messages that traveled over facilities connecting <<customer\_short\_name>>'s CCS7 network and BellSouth's CCS7 network, BellSouth agrees that for the purposes of billing BellSouth for signaling messages for any given month, <<customer\_short\_name>> may use the total number of signaling messages that BellSouth's signaling bill to <<customer\_short\_name>> indicates have traveled over facilities connecting <<customer\_short\_name>>'s CCS7 network and BellSouth's CCS7 network for that same month. When <<customer\_short\_name>> implements a system that is capable of counting the total number of signaling messages that travel over facilities connecting <<customer\_short\_name>>'s CCS7 network and BellSouth's CCS7 network, <<customer\_short\_name>> will use the number of signaling messages counted by such system for the purposes of billing BellSouth for signaling messages, subject to BellSouth's right to contest the accuracy of the number of signaling messages counted by such system.

6.8.1.4.4 For the purposes of billing BellSouth for signaling messages, <<customer\_short\_name>> will apply the SPIU/SPLU provided by BellSouth (which can, at BellSouth's option, be the same as the PIU/PLU that BellSouth provides for minutes of use) to the number of messages calculated pursuant to Paragraph 6.8.1.4.3 above.

6.9 RATES AND CHARGES ASSOCIATED WITH SS7

6.9.1	Message Charge for ISUP Messages	RATE
	Per signaling message	Bill & Keep

6.9.2	Message Charge for TCAP Messages	RATE
	Per signaling message	Bill& Keep

6.9.3 LINE INFORMATION DATA BASE SERVICE

RATE PER QUERY

Per Access Transport Query	Exhibit A of Attachment 2 for UNE-P Only, Tariff Rate for All Others
----------------------------	--

Per Validation Service Query	Exhibit A of Attachment 2 for UNE-P Only, Tariff Rate for All Others
------------------------------	--

Per OLNS Service Query	Tariff Rate
------------------------	-------------

6.9.4 LOCAL NUMBER PORTABILITY DATA BASE SERVICE

Per LNP Query	Exhibit A of Attachment 2 for UNE-P Only
---------------	--

Negotiated Rates Pursuant to a Separate Agreement for All Others

6.9.5 800 DATA BASE SERVICE

Per 800 Query	Exhibit A of Attachment 2 for UNE- P Only, Tariff Rate for All Others
---------------	--

## 7. FORECASTING FOR TRUNK PROVISIONING

- 7.1 Within six (6) months after execution of this Agreement, <<customer\_short\_name>> shall provide an initial interconnection trunk group forecast for each LATA in which it plans to provide service within BellSouth's region. BellSouth's reciprocal trunking forecasts will be based upon information provided by <<customer\_short\_name>> in the initial forecast. If <<customer\_short\_name>> refuses to provide such information, BellSouth shall provide reciprocal trunking forecasts based only on existing trunk group growth and BellSouth's annual estimated percentage of BellSouth subscriber line growth. After the exchange of each Party's forecast, the Parties shall conduct a joint planning meeting to develop a joint interconnection trunk group forecast. Each forecast provided under this Section shall be deemed "Confidential Information" under the General Terms and Conditions of this Agreement.
- 7.2 The Parties shall use best efforts to make the initial and annual subsequent forecasts as accurate as possible based on reasonable engineering criteria. In addition, the Parties agree to proactively manage their interconnection trunking arrangements and use best efforts to timely notify each other if forecasted need quantities change or if a known or anticipated network event that may create a blocking situation is likely to occur during the time period between joint planning meetings. Joint planning meetings shall be conducted via conference call, unless mutual agreement is reached otherwise.
- 7.3 At a minimum, the joint forecast shall include the projected quantity of Transit Trunks, <<customer\_short\_name>>-to-BellSouth one-way trunks (<<customer\_short\_name>> Trunks), BellSouth-to-<<customer\_short\_name>> one-way trunks (Reciprocal Trunks) and/or two-way interconnection trunks, if the Parties have agreed to interconnect using two-way trunking to transport the Parties' Local Traffic, ISP-Bound Traffic and IntraLATA Toll Traffic. The quantities shall be projected for a minimum of six months and shall include an estimate of the current year plus the next two years total forecasted quantities. The Parties shall mutually develop Reciprocal Trunk Groups and/or two-way interconnection trunk forecast quantities.
- 7.4 All forecasts shall include, at a minimum, Access Carrier Terminal Location (ACTL), trunk group type (local/intraLATA toll, Transit, Operator Services, 911, etc.), A location/Z location (CLLI codes for <<customer\_short\_name>> location and BellSouth location where the trunks shall terminate), interface type (e.g., DS1), Direction of Signaling, Trunk Group Number, if known, (commonly referred to as the 2-6 code) and forecasted trunks in service each year (cumulative).
- 7.5 The submitting and development of interconnection trunk forecasts shall not replace the ordering process for local interconnection trunks. Each Party shall exercise its best efforts and act in good faith to plan for and provide the quantity

of interconnection trunks mutually forecasted. However, the provision of the forecasted quantity of interconnection trunks is subject to trunk terminations and facility capacity existing at the time the trunk order is submitted and the provisioning party shall not be responsible for a lack of interconnection trunks provided that the provisioning party can establish that best efforts and good faith have been exercised.

## 8. TRUNK UTILIZATION

8.1 For the Reciprocal Trunk Groups that cannot overflow traffic to another trunk group (Reciprocal Final Trunk Groups), BellSouth and <<customer\_short\_name>> shall monitor traffic on each interconnection Reciprocal Final Trunk Group that is ordered and installed. The Parties agree that the Reciprocal Final Trunk Groups will be utilized at 60 percent (60%) of the time consistent busy hour utilization level within 180 days of installation. The Parties agree that the Reciprocal Final Trunk Groups will be utilized at eighty percent (80%) of the time consistent busy hour utilization level within 365 days of installation. Any Reciprocal Final Trunk Group not meeting the minimum thresholds set forth in this Section are defined as "Under-utilized" trunks. BellSouth may disconnect any Under-utilized Reciprocal Final Trunk Groups and, for trunks not in excess of <<customer\_short\_name>>'s forecast, <<customer\_short\_name>> shall refund to BellSouth the associated nonrecurring and recurring trunk and facility charges paid by BellSouth, if any.

8.1.1 BellSouth's CISC will notify <<customer\_short\_name>> of any under-utilized Reciprocal Trunk Groups and the number of such trunk groups that BellSouth wishes to disconnect. BellSouth will provide supporting information either by email or facsimile to the designated <<customer\_short\_name>> interface. <<customer\_short\_name>> will provide concurrence with the disconnection in seven (7) business days or will provide specific information supporting why the trunks should not be disconnected. Such supporting information should include expected traffic volumes (including traffic volumes generated due to Local Number Portability) and the timeframes within which <<customer\_short\_name>> expects to need such trunks. BellSouth's CISC Project Manager and Circuit Capacity Manager will discuss the information with <<customer\_short\_name>> to determine if agreement can be reached on the number of Reciprocal Final Trunk Groups to be removed. If no agreement can be reached, BellSouth will issue disconnect orders to <<customer\_short\_name>>. Notwithstanding any other provision to this Agreement, the Parties will disconnect the underutilized trunks no sooner than two weeks after <<customer\_short\_name>> receives such disconnect orders, unless the parties mutually agree to do so sooner.

- 8.1.2 To the extent that any interconnection trunk group is utilized at a time-consistent busy hour of eighty percent (80%) or greater, the Parties may review the trunk groups and, if necessary, shall negotiate in good faith for the installation of augmented facilities.
- 8.2 For the two-way trunk groups that cannot overflow traffic to another trunk group and other than alternate final trunk groups, BellSouth and <<customer\_short\_name>> shall monitor traffic on each interconnection trunk group that is ordered and installed. The Parties agree that within 180 days of the installation of the BellSouth two-way trunk or trunks, the trunks will be utilized at 60 percent (60%) of the time consistent busy hour utilization level. The Parties agree that within 365 days of the installation of a trunk or trunks, the trunks will be utilized at eighty percent (80%) of the time consistent busy hour utilization level. Any trunk or trunks not meeting the minimum thresholds set forth in this Section are defined as "Under-utilized" trunks. BellSouth will request the disconnection of any Under-utilized two-way trunk(s) and, for trunks not in excess of <<customer\_short\_name>>'s forecast, <<customer\_short\_name>> shall refund to BellSouth the associated nonrecurring and recurring trunk and facility charges paid by BellSouth, if any.
- 8.2.1 BellSouth's LISC will notify <<customer\_short\_name>> of any under-utilized two-way trunk groups and the number of trunks that BellSouth wishes to disconnect. BellSouth will provide supporting information either by email or facsimile to the designated <<customer\_short\_name>> interface. <<customer\_short\_name>> will provide concurrence with the disconnection in seven (7) business days or will provide specific information supporting why the two-way trunks should not be disconnected. Such supporting information should include expected traffic volumes (including traffic volumes generated due to Local Number Portability) and the timeframes within which <<customer\_short\_name>> expects to need such trunks. BellSouth's CISC Project Manager and Circuit Capacity Manager will discuss the information with <<customer\_short\_name>> to determine if agreement can be reached on the number of trunks to be removed. If no agreement can be reached, <<customer\_short\_name>> will issue disconnect orders to BellSouth. Notwithstanding any other provision to this Agreement, the Parties will disconnect the underutilized trunks no sooner than two weeks after <<customer\_short\_name>> receives such disconnect orders, unless the parties mutually agree to do so sooner.
- 8.2.2 To the extent that any interconnection trunk group is utilized at a time-consistent busy hour of eighty percent (80%) or greater, the Parties shall review the trunk groups and, if necessary, shall negotiate in good faith for the installation of augmented facilities.

**9. INTERFERENCE OR IMPAIRMENT**

- 9.1** As soon as possible and in no case later than twenty-four (24) hours after receipt of notification of blocking of traffic originated within the other Party's network, the Parties shall determine and begin work to implement reasonable corrective measures in a manner consistent with industry practices.
- 9.2** In the event of an outage or trouble in any arrangement, facility, or service being provided by BellSouth hereunder, BellSouth will follow procedures for isolating and clearing the outage or trouble that are no less favorable than those that apply to comparable arrangements, facilities, or services being provided by BellSouth to itself, Affiliate or any other carrier whose network is connected to that of BellSouth.
- 9.3** BellSouth will use best efforts to provide <<customer\_short\_name>> with at least thirty (30) days advance notification of scheduled maintenance activity. Upon such notice, <<customer\_short\_name>> may submit a reasonable request for additional information relevant to the scheduled maintenance activity and BellSouth shall provide such information to the extent the scheduled maintenance activity may impact <<customer\_short\_name>> and such information is reasonably necessary for <<customer\_short\_name>> to identify and analyze potential risks associated with such maintenance. BellSouth may expedite or delay scheduled maintenance as a result of unscheduled maintenance or other unforeseen events. In those instances where BellSouth will not perform scheduled maintenance at the announced times, BellSouth will make best efforts to provide <<customer\_short\_name>> with as much notice as is reasonably possible concerning the changed schedule.
- 9.4** For switch software/processor updates, software upgrades/new releases to the SONET transport network elements, or other major scheduled events which might impact <<customer\_short\_name>>, BellSouth shall use best efforts to provide <<customer\_short\_name>> with at least thirty (30) days advance notification of scheduled maintenance activity. Upon such notice, <<customer\_short\_name>> may submit a reasonable request for additional information relevant to the scheduled maintenance activity and BellSouth shall provide such information to the extent the scheduled maintenance activity may impact <<customer\_short\_name>> and such information is reasonably necessary for <<customer\_short\_name>> to identify and analyze potential risks associated with such maintenance.
- 9.5** BellSouth will provide <<customer\_short\_name>>'s Network Operations Center with written notice when translations are scheduled to be modified on <<customer\_short\_name>>'s trunk groups. BellSouth shall use best efforts to provide such notice 30 days in advance of such scheduled activity, or as close thereto as possible.

9.6 [Parties Disagree]

[Xspedius Version] Once <<customer\_short\_name>> determines that there is an outage that encompasses either a particular section of the network or the whole network, then <<customer\_short\_name>> shall generate a trouble ticket to the CISC. After issuing the trouble ticket, <<customer\_short\_name>> will notify the appropriate BellSouth representative in the CISC via telephone. <<customer\_short\_name>> may then send an email confirmation to such BellSouth representative. BellSouth will work cooperatively with <<customer\_short\_name>> to determine the appropriate steps to resolve such outage. Additionally, <<customer\_short\_name>> will provide BellSouth with any applicable information that is necessary to resolve such outage and the Parties will work cooperatively to take all steps necessary to resolve the outage. **Upon request, BellSouth will provide a written root cause analysis report for all global outages, and for any trunk group outage that has occurred 3 or more times in a 60 day period. BellSouth shall use best efforts to provide such report within five (5) business days after the request for it is made.**

[BellSouth Version] Once <<customer\_short\_name>> determines that there is an outage that encompasses either a particular section of the network or the whole network, then <<customer\_short\_name>> shall generate a trouble ticket to the CISC. After issuing the trouble ticket, <<customer\_short\_name>> will notify the appropriate BellSouth representative in the CISC via telephone. <<customer\_short\_name>> may then send an email confirmation to such BellSouth representative. BellSouth will work cooperatively with <<customer\_short\_name>> to determine the appropriate steps to resolve such outage. Additionally, <<customer\_short\_name>> will provide BellSouth with any applicable information that is necessary to resolve such outage and the Parties will work cooperatively to take all steps necessary to resolve the outage. <<customer\_short\_name>> may submit a reasonable request to BellSouth for a written analysis of the cause of any global outage affecting <<customer\_short\_name>>'s network. BellSouth shall use best efforts to provide such report within thirty (30) days of such request.

10. COMPENSATION FOR LOCAL TRAFFIC, ISP-BOUND TRAFFIC AND INTRALATA TOLL TRAFFIC

10.1 [Parties Disagree]

[Xspedius Version] Notwithstanding any other provision in this Attachment 3, the Parties shall pay each other reciprocal compensation for the transport and termination of Local Traffic at the elemental rates for end office switching, tandem switching and transport, as set forth in Exhibit A. The terminating Party is entitled to bill and the originating Party is obligated to pay reciprocal compensation to the terminating Party at a symmetrical tandem interconnection rate, inclusive of end office switching, tandem switching and transport.

[BellSouth Version] Each Party shall pay compensation to the other Party for the per minute of use rate elements associated with the Call Transport and Termination of Local Traffic.

10.2 [Parties Disagree]

[Xspedius Version] For the per minute of use rate elements associated with Call Transport and Termination, the Parties shall compensate each other at the rate of \$0.0007 per minute of use for ISP-bound Traffic

[BellSouth Version] For the per minute of use rate elements associated with Call Transport and Termination of **ISP-bound Traffic**, the Parties shall compensate each other at the rate of \$0.0007 **per minute of use subject to the ceiling of minutes as set forth below.**

10.3 [Parties Disagree]

[Xspedius Version] No section.

[BellSouth Version] For ISP-bound Traffic exchanged from the Effective Date through the Expiration Date of this Agreement, compensation as set forth in Section 10.2 shall be billed by the terminating Party to the originating Party on the ISP-bound minutes up to a ceiling of ISP-bound minutes, which shall be calculated as set forth in the ISP Order on Remand. The Parties shall exchange data to determine the appropriate volume of minutes to be utilized.

10.4 Notwithstanding the definitions of Local Traffic and ISP-bound Traffic in this Attachment, and pursuant to the FCC's Order on Remand and Report and Order in CC Docket 99- 68 released April 27, 2001 ("ISP Order on Remand"), BellSouth and <<customer\_short\_name>> agree to the rebuttable presumption that all combined Local and ISP-bound Traffic delivered to BellSouth or <<customer\_short\_name>> that exceeds a 3:1 ratio of terminating to originating traffic on a statewide basis shall be considered ISP-bound Traffic for compensation purposes. BellSouth and <<customer\_short\_name>> further agree to the rebuttable presumption that all combined Local and ISP-bound Traffic delivered to BellSouth or <<customer\_short\_name>> that does not exceed a 3:1 ratio of terminating to originating traffic on a statewide basis shall be considered Local Traffic for compensation purposes.

10.5 For the convenience of the Parties, BellSouth shall post on its web site a list of NPA-NXXs that constitute local calls from BellSouth's originating NPA-NXXs for each local calling area in the BellSouth region. Such list shall be updated on a weekly basis.

10.6 The appropriate elemental rates set forth in Exhibit A of this Attachment shall apply for Transit Traffic as described in this Attachment and to Multiple Tandem Access as in this Attachment.



- 10.7** Neither Party shall represent Switched Access Traffic, as defined in this Attachment, as Local Traffic or ISP-bound Traffic for purposes of determining compensation for the call.
- 10.8** For terminating its intraLATA toll traffic on the other company's network, the originating Party will pay the terminating Party the terminating Party's current intrastate or interstate, whichever is appropriate, terminating switched access tariff rates as set forth in as set forth in that Party's Access Services Tariffs as filed and in effect with the FCC or Commission, or as posted on the web, if no tariff is required. The appropriate charges will be determined by the routing of the call. Additionally, if one Party is the other Party's End User's presubscribed interexchange carrier or if one Party's End User uses the other Party as an interexchange carrier on a 101XXXX basis, the originating Party's originating Switched Access Traffic rates as set forth in that Party's Intrastate or Interstate Access Services Tariff as filed and in effect with the FCC or appropriate Commission, or as posted on the web, if no tariff is required.
- 10.9** If <<customer\_short\_name>> assigns NPA/NXXs to specific BellSouth rate centers within the LATA and assigns numbers from those NPA/NXXs to <<customer\_short\_name>> End Users physically located outside of that LATA, BellSouth originated traffic that is not bound for an Internet Service Provider ("ISP") and originates from within the LATA where the NPA/NXXs are assigned and is delivered to a <<customer\_short\_name>> End User physically located outside of such LATA shall not be deemed Local Traffic. Further, <<customer\_short\_name>> agrees to identify such traffic to BellSouth, to the extent technically feasible, and to compensate BellSouth for originating and transporting such non-local traffic to <<customer\_short\_name>> at BellSouth's switched access tariff rates.
- 10.9.1** The Parties have been unable to agree on the treatment of calls where <<customer\_short\_name>> assigns NPA/NXXs to specific BellSouth rate centers within the LATA and assigns numbers from those NPA/NXXs to <<customer\_short\_name>> End Users physically located outside of that LATA and such End Users are Internet Service Providers ("ISPs"). Notwithstanding the foregoing, and without waiving any rights with respect to either Party's position as to the treatment of such calls, the Parties agree that, for purposes of this Agreement, traffic delivered to an End User that is an ISP physically located outside of such LATA shall be considered ISP-bound Traffic as defined in this Attachment.
- 10.10** **Jurisdictional Reporting.**
- 10.10.1** **Percent Local Usage.** Each Party shall report to the other a Percent Local Usage (PLU) factor. The application of the PLU will determine the amount of Local/ISP-Bound minutes to be billed to the other Party. Local and ISP-bound

Traffic shall be treated as Local for purposes of calculating the PLU. Requirements associated with PLU calculation and reporting shall be as set forth in BellSouth's Jurisdictional Factors Reporting Guide, attached hereto as Exhibit F.

10.10.2 [Parties Disagree]

[Xspedius Version] **No Section.**

[BellSouth Version] **Percent Local Facility.** Each Party shall report to the other a Percent Local Facility (PLF) factor. The application of the PLF will determine the portion of switched dedicated transport to be billed per the local jurisdiction rates. The PLF shall be applied to Multiplexing, Local Channel and Interoffice Channel Switched Dedicated Transport utilized in the provision of local interconnection trunks. Requirements associated with PLF calculation and reporting shall be as set forth in BellSouth's Jurisdictional Factors Reporting Guide, attached hereto as Exhibit F.

10.10.3 **Percent Interstate Usage.** Each Party shall report to the other a Percent Interstate Usage (PIU) factor. Requirements associated with PIU calculation and reporting shall be as set forth in BellSouth's Jurisdictional Factors Reporting Guide, attached hereto as Exhibit F.

10.10.4 [Parties Disagree]

[Xspedius Version] **In Lieu of Jurisdictional Factors Reported.**

Notwithstanding the provisions in Section 9.8.1, 9.8.2, and 9.8.3 above, where the terminating Party has message recording technology that identifies the jurisdiction of traffic terminated as defined in this Agreement, such information shall, at the terminating Party's option, **either (1) be used to bill based upon actual measurements and jurisdictionalization, in lieu of factors reported by the originating party, or (2)** be utilized to determine the appropriate jurisdictional reporting factors, in lieu of those provided by the originating Party. In the event that the terminating Party opts to utilize its own data to determine jurisdictional reporting factors, such terminating Party shall notify the originating Party at least 30 days prior to the beginning of the calendar quarter in which the terminating Party will begin to utilize its own data.

[BellSouth Version] **In Lieu of Jurisdictional Factors Reported.**

Notwithstanding the provisions in Section 9.8.1, 9.8.2, and 9.8.3 above, where the terminating Party has message recording technology that identifies the jurisdiction of traffic terminated as defined in this Agreement, such information shall, at the terminating Party's option, be utilized to determine the appropriate

jurisdictional reporting factors, in lieu of those provided by the originating Party. In the event that the terminating Party opts to utilize its own data to determine jurisdictional reporting factors, such terminating Party shall notify the originating Party at least 30 days prior to the beginning of the calendar quarter in which the terminating Party will begin to utilize its own data.

10.10.5 [Parties Disagree]

[Xspedius Version] Upon the request of the originating Party, the terminating Party shall provide supporting data for the jurisdictional factors **or actual measurements** utilized by the terminating Party in lieu of those reported by the originating Party.

[BellSouth Version] Upon the request of the originating Party, the terminating Party shall provide supporting data for the jurisdictional factors utilized by the terminating Party in lieu of those reported by the originating Party.

10.10.6 [Parties Disagree]

[Xspedius Version] Upon either Party's request, the Parties will work in good faith to resolve the discrepancy between the factors submitted by the originating party and factors **or actual measurements** utilized by the terminating party pursuant to Section 9.8.4 above. In the event that the Parties are unable to mutually agree as to the appropriate resolution, the Parties may negotiate a mutually agreeable resolution based on the data specific to the traffic patterns of the originating party or either Party may request an audit of the factors or actual measurements in accordance with Section 9.8.7 below.

[BellSouth Version] Upon either Party's request, the Parties will work in good faith to resolve the discrepancy between the factors submitted by the originating party and factors utilized by the terminating party pursuant to Section 9.8.4 above. In the event that the Parties are unable to mutually agree as to the appropriate resolution, the Parties may negotiate a mutually agreeable resolution based on the data specific to the traffic patterns of the originating party or either Party may request an audit of the factors in accordance with Section 9.8.7 below.

10.10.7 [Parties Disagree]

[Xspedius Version] Audits. On thirty (30) days written notice, each Party must provide the other the ability and opportunity to conduct an annual audit of the jurisdictional reporting factors as reported or factors **or actual measurements**

utilized pursuant to this Attachment 3 to ensure the proper billing of traffic-. BellSouth and <<customer\_short\_name>> shall retain records of call detail for a minimum of six months from which the jurisdictional reporting factors can be ascertained. The audit shall be conducted during normal business hours at an office designated by the Party being audited. Audit requests shall not be submitted more frequently than one (1) time per calendar year. The Parties shall use commercially reasonable efforts to complete audits in as timely a manner as possible. Audits shall be performed by a mutually acceptable independent auditor paid for by the Party requesting the audit. The jurisdictional reporting factors or actual measurements shall be adjusted based upon the audit results and shall apply for the quarter the audit was completed, for the quarter prior to the completion of the audit, and, if factors are used, for the two quarters following the completion of the audit. If, as a result of an audit, either Party is found to have overstated the jurisdictional reporting factors or actual measurements by twenty percentage points (20%) or more, that Party shall reimburse the auditing Party for the cost of the audit.

**[BellSouth Version]** Audits. On thirty (30) days written notice, each Party must provide the other the ability and opportunity to conduct an annual audit of the jurisdictional reporting factors as reported or factors utilized pursuant to this Attachment 3 to ensure the proper billing of traffic-. BellSouth and <<customer\_short\_name>> shall retain records of call detail for a minimum of six months from which the jurisdictional reporting factors can be ascertained. The audit shall be conducted during normal business hours at an office designated by the Party being audited. Audit requests shall not be submitted more frequently than one (1) time per calendar year. The Parties shall use commercially reasonable efforts to complete audits in as timely a manner as possible. Audits shall be performed by a mutually acceptable independent auditor paid for by the Party requesting the audit. The jurisdictional reporting factors or actual measurements shall be adjusted based upon the audit results and shall apply for the quarter the audit was completed, for the quarter prior to the completion of the audit, and, if factors are used, for the two quarters following the completion of the audit. If, as a result of an audit, either Party is found to have overstated the jurisdictional reporting factors or actual measurements by twenty percentage points (20%) or more, that Party shall reimburse the auditing Party for the cost of the audit.

## **10.11 Compensation for 8XX Traffic <sub>2</sub>**

10.11.1 **Compensation for 8XX Traffic**. Each Party shall compensate the other pursuant to the appropriate Switched Access charges, including the database query charge as applicable, as set forth in the providing Party's tariff, as filed and effective with the FCC or Commission, or reasonable and non-discriminatory web-posted listing if the FCC or Commission does not require filing of a tariff.

- 10.11.2 **Records for 8XX Billing.** Each Party will provide to the other the appropriate records necessary for billing intraLATA 8XX customers. The records provided will be in a standard EMI format.
- 10.11.3 **8XX Access Toll Free Dialing Ten Digit Screening (“TFD”).** BellSouth’s provision of TFD to <<customer\_short\_name>> requires interconnection from <<customer\_short\_name>> to BellSouth’s 8XX Signal Channel Point (SCP). Such interconnections shall be established pursuant to BellSouth’s Common Channel Signaling Interconnection Guidelines and Telcordia’s CCS Network Interface Specification document, TR-TSV-000905. <<customer\_short\_name>> shall establish SS7 interconnection at the BellSouth Local Signal Transfer Points serving the BellSouth 8XX SCPs that <<customer\_short\_name>> desires to query. The terms and conditions for 8XX TFD are set out in BellSouth’s Intrastate Access Services Tariff.
- 10.12** Switched Access Traffic is defined as telephone calls requiring local transmission or switching services for the purpose of the origination or termination of Telephone Toll Service. Switched Access Traffic includes the following types of traffic: Feature Group A, Feature Group B, Feature Group C, Feature Group D, toll free access (e.g., 800/877/888), and 900 access services. Switched Access Service Traffic does not include Local Traffic and ISP-Bound Traffic originated by one Party and terminated by the other. The Parties have been unable to agree as to whether “Voice-Over-Internet Protocol” transmissions (“VOIP”) which cross LATA boundaries constitute Switched Access Service Traffic. Notwithstanding the foregoing, and without waiving any rights with respect to either Party’s position as to the jurisdictional nature of VOIP, the Parties agree amend this Agreement in accordance with the General Terms and Conditions of this Agreement to abide by any effective and applicable FCC rules and orders regarding the nature of such traffic and the compensation payable by the Parties for such traffic, if any
- 10.12.1 If the BellSouth End User chooses <<customer\_short\_name>> as their presubscribed interexchange carrier, or if the BellSouth End User uses <<customer\_short\_name>> as an interexchange carrier on a 101XXXX basis, BellSouth will charge <<customer\_short\_name>> the appropriate BellSouth tariff charges for originating switched access services.
- 10.12.2 Where the originating Party delivers Switched Access Traffic to the terminating Party, the originating Party will pay the terminating Party terminating switched access charges as set forth in the providing Party’s tariff, as filed and effective with the FCC or Commission, or reasonable and non-discriminatory web-posted listing if the FCC or Commission does not require filing of a tariff.
- 10.12.3 When one Party’s end office switch, subtending the other Party’s Access Tandem switch for receipt or delivery of switched access traffic, provides an access service connection to or from an interexchange carrier (“IXC”) by either a direct

trunk group to the IXC utilizing the other Party's facilities, or via the other Party's tandem switch, each Party will provide its own access services to the IXC and bill on a multi-bill, multi-tariff meet-point basis. Each Party will bill its own access services rates to the IXC with the exception of the interconnection charge. The interconnection charge will be billed by the Party providing the end office function. The Parties will use the Multiple Exchange Carrier Access Billing (MECAB) guidelines to establish meet point billing for all applicable traffic. Thirty (30)-day billing periods will be employed for these arrangements. To the extent either party is providing the tandem function, that party (i.e. Initial Billing Company) agrees to provide to the other company (i.e. Subsequent Billing Company), as defined in MECAB, at no charge, the switched access detailed usage data, within no more than sixty (60) days after the recording date. Each company will notify the other when it is not feasible to meet these requirements so that the customers may be notified for any necessary revenue accrual associated with the significantly delayed recording or billing. As business requirements change, data reporting requirements may be modified as necessary, by mutual agreement of the Parties or per a change in industry standards.

10.12.4

[Parties Disagree]

**[Xspedius Version]** In the event that either Party fails to provide accurate switched access detailed usage data to the other Party within 90 days after the recording date and the receiving Party is unable to bill and/or collect access revenues due to the sending Party's failure to provide such data within said time period, then the Party failing to send the data as specified herein shall be liable to the other Party in an amount equal to the unbillable or uncollectible revenues. Each company will provide complete documentation to the other to substantiate any claim of such unbillable or uncollectible access revenues. In the event that the Parties disagree as to the liability of the Initial Billing Party for such unbillable or uncollectible revenues, then either Party may invoke the Dispute Resolution process set forth in this Agreement.

**[BellSouth Version]** In the event that the Initial Billing Party, as defined in Section 7.4.4 herein, was provided the accurate switched access detailed usage data in a manner that allowed the Initial Billing Party to generate and provide such data to the Subsequent Billing Party in a reasonable timeframe and where the Initial Billing Party failed to provide notice to the Subsequent Billing Party of any inability to provide such data within a reasonable and nondiscriminatory timeframe and the Subsequent Billing Party is unable to bill and/or collect access revenues due to the Initial Billing Party's failure to provide such data within said time period, then the Initial Billing Party shall be liable to the other Party in an amount equal to the unbillable or uncollectible revenues. Each company will provide complete documentation to the other to substantiate any claim of such unbillable or uncollectible revenues. In the event that the Parties disagree as to the liability of the Initial Billing Party

for such unbillable or uncollectible revenues, then either Party may invoke the Dispute Resolution process set forth in this Agreement

- 10.12.5 The Initial Billing Company will retain for a minimum period of sixty (60) days, access message detail sufficient to recreate any data that is lost or damaged by the tandem provider company or any third party involved in processing or transporting data.
- 10.12.6 Initial Billing Company agrees to recreate the lost or damaged data within forty-eight (48) hours of notification by the other or by an authorized third party handling the data.
- 10.12.7 Initial Billing Company also agrees to process the recreated data within forty-eight (48) hours of receipt at its data processing center.
- 10.12.8 All claims for unbillable or uncollectible revenue should be filed with the Initial Billing Company within 120 days of the receipt of the usage record
- 10.12.9 The Initial Billing Party shall keep records of its billing activities relating to jointly-provided Intrastate and Interstate Switched Access Traffic in sufficient detail to permit the Subsequent Billing Party to, by formal or informal review or audit, to verify the accuracy and reasonableness of the jointly-provided access billing data provided by the Initial Billing Party. Each Party agrees to cooperate in such formal or informal reviews or audits and further agrees to jointly review the findings of such reviews or audits in order to resolve any differences concerning the findings thereof. In the absence of mutual agreement otherwise, the Audit provisions set forth in Section 9.8.4 shall govern.
- 10.13** Each Party shall provide tandem switching and transport services for the other Party's Transit Traffic. Rates for Local Transit Traffic and ISP-Bound Transit Traffic shall be the applicable Call Transport and Termination charges (i.e., common transport and tandem switching charges; and tandem intermediary charge; end office switching charge is not applicable) as set forth in Exhibit A to this Attachment. Rates for Switched Access Transit Traffic shall be the applicable charges as set forth in the applicable Party's Commission approved Interstate or Intrastate Switched Access tariffs as filed and effective with the FCC or Commission, or reasonable and non-discriminatory web-posted listing if the FCC or Commission does not require filing of a tariff. Billing associated with all Transit Traffic shall be pursuant to MECAB guidelines.
- 10.13.1 Traffic between <<customer\_short\_name>> and Wireless Type 1 third parties or a third party CLEC utilizing BellSouth switching (including resellers and UNE-P providers) shall not be treated as Transit Traffic from a routing or billing perspective. Traffic originated by a Wireless Type 1 third party or a third party CLEC utilizing BellSouth switching (including resellers and UNE-P providers) shall be treated as BellSouth-originated traffic and BellSouth shall compensate

<<customer\_short\_name>> for transport and termination of such traffic based on the classification of such traffic as Local Traffic, ISP-Bound Traffic, IntraLATA Toll or Switched Access Service Traffic in accordance with the terms of this Attachment.

- 10.13.2 Traffic between <<customer\_short\_name>> and Wireless Type 2A third parties shall not be treated as Transit Traffic from a routing or billing perspective until BellSouth and the Wireless Type 2A carrier have the capability to properly meet-point-bill in accordance with MECAB guidelines. Until such time, such traffic originated by Wireless Type 2A third parties shall be treated as BellSouth-originated traffic and BellSouth shall compensate <<customer\_short\_name>> for transport and termination of such traffic based on the classification of such traffic as Local Traffic, ISP-Bound Traffic, IntraLATA Toll or Switched Access Service Traffic in accordance with the terms of this Attachment.
- 10.13.3 Traffic between BellSouth and Wireless Type 1 third parties or a third party CLEC utilizing <<customer\_short\_name>> switching shall not be treated as Transit Traffic from a routing or billing perspective. Such traffic originated by a Wireless Type 1 third party or a third party CLEC utilizing <<customer\_short\_name>> switching shall be treated as <<customer\_short\_name>>-originated traffic and <<customer\_short\_name>> shall compensate BellSouth for transport and termination of such traffic based on the classification of such traffic as Local Traffic, ISP-Bound Traffic, IntraLATA Toll or Switched Access Service Traffic in accordance with the terms of this Attachment.
- 10.13.4 Traffic between BellSouth and Wireless Type 2A third parties shall not be treated as Transit Traffic from a routing or billing perspective until <<customer\_short\_name>> and the Wireless Type 2A carrier have the capability to properly meet-point-bill in accordance with MECAB guidelines. Until such time, such traffic originated by Wireless Type 2A third parties shall be treated as <<customer\_short\_name>> -originated traffic and <<customer\_short\_name>> shall compensate BellSouth for transport and termination of such traffic based on the classification of such traffic as Local Traffic, ISP-Bound Traffic, IntraLATA Toll or Switched Access Service Traffic in accordance with the terms of this Attachment.
- 10.13.5 [Parties Disagree]
- [Xspedius Version] BellSouth agrees to deliver Transit Traffic originated by <<customer\_short\_name>> to the terminating carrier; provided, however, that <<customer\_short\_name>> is solely responsible for negotiating and executing any appropriate contractual agreements with the terminating carrier for the exchange of Transit Traffic through the BellSouth network. BellSouth will not be liable for any compensation to the terminating carrier or to



<<customer\_short\_name>> for transiting <<customer\_short\_name>>-originated or terminated Transit Traffic. **Notwithstanding any other provision of this Attachment**, in the event that the terminating third party carrier imposes on BellSouth any charges or costs for the delivery of Transit Traffic originated by <<customer\_short\_name>>, <<customer\_short\_name>> shall reimburse BellSouth for all charges paid by BellSouth, **which BellSouth is contractually obligated to pay**, provided that BellSouth notifies and, upon request, provides <<customer\_short\_name>> with a copy of such an invoice, if available, or other equivalent supporting documentation (if an invoice is not available), and proof of payment and other applicable supporting documentation. BellSouth will provide such notice and information in a timely, reasonable and nondiscriminatory manner. BellSouth shall diligently review, dispute and pay such third party invoices (or equivalent) in a manner that is at parity with its own practices for reviewing, disputing and paying such invoices (or equivalent) **when no similar reimbursement provision applies**. Additionally, the Parties agree that any billing to a third party or other telecommunications carrier under this section shall be pursuant to MECAB procedures.

[BellSouth Version] BellSouth agrees to deliver Transit Traffic originated by <<customer\_short\_name>> to the terminating carrier; provided, however, that <<customer\_short\_name>> is solely responsible for negotiating and executing any appropriate contractual agreements with the terminating carrier for the exchange of Transit Traffic through the BellSouth network. BellSouth will not be liable for any compensation to the terminating carrier or to <<customer\_short\_name>> for transiting <<customer\_short\_name>>-originated or terminated Transit Traffic. In the event that the terminating third party carrier imposes on BellSouth any charges or costs for the delivery of Transit Traffic originated by <<customer\_short\_name>>, <<customer\_short\_name>> shall reimburse BellSouth for all charges paid by BellSouth, provided that BellSouth notifies <<customer\_short\_name>> and, upon request, provides <<customer\_short\_name>> with a copy of such an invoice, if available, or other equivalent supporting documentation (if an invoice is not available), and proof of payment and other applicable supporting documentation. BellSouth will use **commercially reasonable** efforts to provide such notice and information in a timely, reasonable and nondiscriminatory manner. BellSouth shall diligently review, dispute and pay such third party invoices (or equivalent) in a manner that is at parity with its own practices for reviewing, disputing and paying such invoices (or equivalent) under the same circumstances. Once <<customer\_short\_name>> reimburses BellSouth for any such payments, any disputes with respect to such charges shall be between <<customer\_short\_name>> and the terminating third party carrier. Additionally, the Parties agree that any billing to a third party or other telecommunications carrier under this section shall be pursuant to MECAB procedures.

- 10.13.6 Except for as provided in 7.6.3 and 7.6.4, transit charges as described in this Attachment shall only be assessed on the carrier originating Transit Traffic and shall not be assessed on the terminating carrier.
- 10.13.7 Transit charges associated with the provisioning of toll free services (e.g., 800/888/877) shall be assessed upon the terminating carrier and shall not be imposed on the originating carrier.
- 10.14** Records Exchange and Misrouting of Traffic.
- 10.14.1 Misrouted Traffic.
- 10.14.1.1 The Parties shall route traffic to each other in a manner consistent with the Trunk Group Architectures selected by the Parties and as set forth in Section 4 of this Attachment 3, except as otherwise set forth in this Agreement (e.g., overflow) or in instances where a third party causes either Party to route traffic in a manner that is inconsistent with this Attachment.
- 10.14.1.2 In instances of misrouting, either Party may request that the Parties investigate, identify the cause of, and correct misrouting to the extent technically and economically feasible.
- 10.14.1.3 In the event that misrouting results in either Party's inability to bill or collect revenues from a third party and the Parties disagree as to the liability of the other Party for such revenues, then either Party may pursue the Dispute Resolution procedures set forth in this Agreement.
- 10.14.2 Records Exchange
- 10.14.2.1 Where feasible and appropriate, the Parties will generate and exchange all available messages for the purpose of billing third parties, including but not limited to CMRS providers and other LECs.

## **11. FRAME RELAY SERVICE INTERCONNECTION**

- 11.1** In addition to the Local Interconnection services set forth above, BellSouth will offer a network to network Interconnection arrangement between BellSouth's and <<customer\_short\_name>>'s frame relay switches as set forth below. The following provisions will apply only to Frame Relay Service and Exchange Access Frame Relay Service and Managed Shared Frame Relay Service in those states in which <<customer\_short\_name>> is certified and providing Frame Relay Service as a Local Exchange Carrier and where traffic is being exchanged between <<customer\_short\_name>> and BellSouth Frame Relay Switches in the same LATA.

- 11.2** *The Parties agree to* establish two-way Frame Relay facilities between their respective Frame Relay Switches to the mutually agreed upon Frame Relay Service point(s) of interconnection (IP(s)) within the LATA. All IPs shall be within the same Frame Relay Network Serving Areas as defined in Appendix A of BellSouth's FCC Tariff #1 except as set forth in this Attachment.
- 11.3** Upon the request of either Party, such interconnection will be established where BellSouth and <<customer\_short\_name>> have Frame Relay Switches in the same LATA. Where there are multiple Frame Relay switches in one central office, an interconnection with any one of the switches will be considered an interconnection with all of the switches at that central office for purposes of routing frame traffic.
- 11.4** The Parties agree to provision local (i.e., intraLATA) Frame Relay Service and Exchange Access Frame Relay Service and Managed Shared Frame Relay Service (both intrastate and interstate) over Frame Relay interconnection facilities between the respective Frame Relay switches and the IPs.
- 11.5** The Parties agree to assess each other reciprocal charges for the facilities that each provides to the other according to the Percent Local Circuit Use Factor (PLCU), determined as follows:
- 11.6** Frame Relay data frames are transported within Virtual Circuits (VC). For the purposes of this Agreement, if the originating and terminating locations of the two-way data frame traffic are in the same LATA , then the traffic on that VC shall be considered local (Local VC).
- 11.7** If the originating and terminating locations of the two-way data frame traffic are not in the same LATA, the traffic on that VC is interLATA (InterLATA VC).
- 11.8** The PLCU is determined by dividing the total number of Local VCs, by the total number of VCs on each Frame Relay facility. To facilitate implementation, <<customer\_short\_name>> may determine its PLCU in aggregate, by dividing the total number of Local VCs in a given LATA by the total number VCs in that LATA. The Parties agree to renegotiate the method for determining PLCU, at either Party's request, and within 90 days, if either Party notifies the other that it has found that this method does not adequately represent the PLCU.
- 11.9** If there are no VCs on a facility when it is billed, the Party requesting the facility will pay the provisioning Party tariffed rates for the facility, unless the requesting and provisioning Party are the same (in which case, no charges will apply).
- 11.10** BellSouth will provide the circuit between the Parties' respective Frame Relay Switches. The Parties will be compensated as follows: BellSouth will invoice, and <<customer\_short\_name>> will pay, the total nonrecurring and recurring charges for the circuit based upon the rates set forth in BellSouth's Interstate Access Tariff, FCC No. 1. <<customer\_short\_name>> will then invoice, and

BellSouth will pay, an amount calculated by multiplying the BellSouth billed charges for the circuit by one-half of <<customer\_short\_name>>'s PLCU.

- 11.11** If <<customer\_short\_name>> requests interconnection for a frame relay switch located outside the serving area in which the IP is located, then <<customer\_short\_name>> may, at its option, purchase facilities and transport between Frame Relay Network Service areas, as defined in Appendix A of the FCC Tariff #1, according to the rates, terms and conditions of the applicable General Subscriber Service Tariff for that state.
- 11.12** Each Party will provide a Frame Relay network-to-network interface ("NNI") port to the other Party for each trunk facility provided pursuant to 8.6 above. Compensation for NNI ports shall be based upon the NNI rates set forth in BellSouth F.C.C. Tariff No. 1. Pursuant to that tariff, <<customer\_short\_name>> may select a month-to-month or term rate structure for the NNI ports BellSouth provides to <<customer\_short\_name>>. Whatever rate structure <<customer\_short\_name>> selects shall be deemed to be the same rate structure that applies to the NNI port <<customer\_short\_name>> provides to BellSouth. There shall be no termination liability to either Party for the local portion of the NNI port as determined by the <<customer\_short\_name>> PLCU at the time of termination.
- 11.13** For NNI ports provided by BellSouth to <<customer\_short\_name>>, BellSouth will invoice, and <<customer\_short\_name>> will pay, the total nonrecurring and recurring charges for the NNI port. <<customer\_short\_name>> will then invoice, and BellSouth will pay, an amount calculated by multiplying the BellSouth billed nonrecurring and recurring charges for the NNI port by one-half of <<customer\_short\_name>>'s PLCU.
- 11.14** For NNI ports provided by <<customer\_short\_name>> to BellSouth, <<customer\_short\_name>> will invoice, and BellSouth will pay, the total non-recurring and recurring charges for the NNI port. BellSouth will then invoice, and <<customer\_short\_name>> will pay, an amount determined as follows: <<customer\_short\_name>>'s combined interLATA and local usage will be calculated by subtracting one-half of <<customer\_short\_name>>'s PLCU factor from one hundred percent. The difference will then be multiplied by the total charges initially billed by <<customer\_short\_name>> for the NNI port. BellSouth will then invoice, and <<customer\_short\_name>> will pay, this amount to BellSouth.
- 11.15** A Permanent Virtual Circuit ("PVC") is a logical channel from a frame relay network interface (e.g., NNI or User Network Interface) to another frame relay network interface. A PVC is created when a Data Link Channel Identifier ("DLCI") is mapped together with another DLCI. Neither Party will charge the other Party for any DLCI or Committed Information Rate ("CIR") charges for the PVC from its Frame Relay switch to its own subscriber's premise.

- 11.16** For the PVC between the <<customer\_short\_name>> and BellSouth Frame Relay switches, compensation for the PVC charges is based upon the rates in BellSouth's Interstate Access Tariff, FCC No. 1.
- 11.17** Compensation for PVC rate elements will be calculated as follows:
- 11.18** If <<customer\_short\_name>> orders a VC connection between a BellSouth subscriber's PVC segment and a PVC segment from the BellSouth Frame Relay switch to the <<customer\_short\_name>> Frame Relay switch, BellSouth will invoice, and <<customer\_short\_name>> will pay, the total nonrecurring and recurring PVC charges for the PVC segment between the BellSouth and <<customer\_short\_name>> Frame Relay switches. If the VC is a Local VC, <<customer\_short\_name>> will then invoice and BellSouth will pay, the total nonrecurring and recurring PVC charges billed for that segment. If the VC is not local, no compensation will be paid to <<customer\_short\_name>> for the PVC segment.
- 11.19** If BellSouth orders a Local VC connection between a <<customer\_short\_name>> subscriber's PVC segment and a PVC segment from the <<customer\_short\_name>> Frame Relay switch to the BellSouth Frame Relay switch, BellSouth will invoice, and <<customer\_short\_name>> will pay, the total nonrecurring and recurring PVC and CIR charges for the PVC segment between the BellSouth and <<customer\_short\_name>> Frame Relay switches. If the VC is a Local VC, <<customer\_short\_name>> will then invoice and BellSouth will pay the total nonrecurring and recurring PVC and CIR charges billed for that segment. If the VC is not local, no compensation will be paid to <<customer\_short\_name>> for the PVC segment.
- 11.20** The Parties agree to compensate each other for requests to change a PVC segment or PVC service order record, according to the Feature Change charge as set forth in the BellSouth access tariff BellSouth Tariff FCC No. 1.
- 11.21** If <<customer\_short\_name>> requests a change, BellSouth will invoice and <<customer\_short\_name>> will pay a Feature Change charge for each affected PVC segment.
- 11.22** If BellSouth requests a change, <<customer\_short\_name>> will invoice and BellSouth will pay a Feature Change charge for each affected PVC segment.
- 11.23** The Parties agree to limit the sum of the CIR for the VCs on a DS1 NNI port to not more than three times the port speed, or not more than six times the port speed on a DS3 NNI port.
- 11.24** Except as expressly provided herein, this Agreement does not address or alter in any way either Party's provision of Exchange Access Frame Relay Service, Managed Shared Frame Relay Service or interLATA Frame Relay Service. All charges by each Party to the other for carriage of Exchange Access Frame Relay

Service or interLATA Frame Relay Service are included in the BellSouth FCC Tariff #1.

- 11.25** <<customer\_short\_name>> will identify and report quarterly to BellSouth the PLCU of the Frame Relay facilities it uses, per Section 1.1.1 above. BellSouth shall not send interLATA frame relay traffic, on behalf of itself or its Affiliates over frame relay interconnection facilities.
- 11.26** Either Party may request a review or audit of the various service components, consistent with the provisions of Section 2 of the BellSouth FCC No.1 Tariff.



# Basic Architecture

Exhibit B

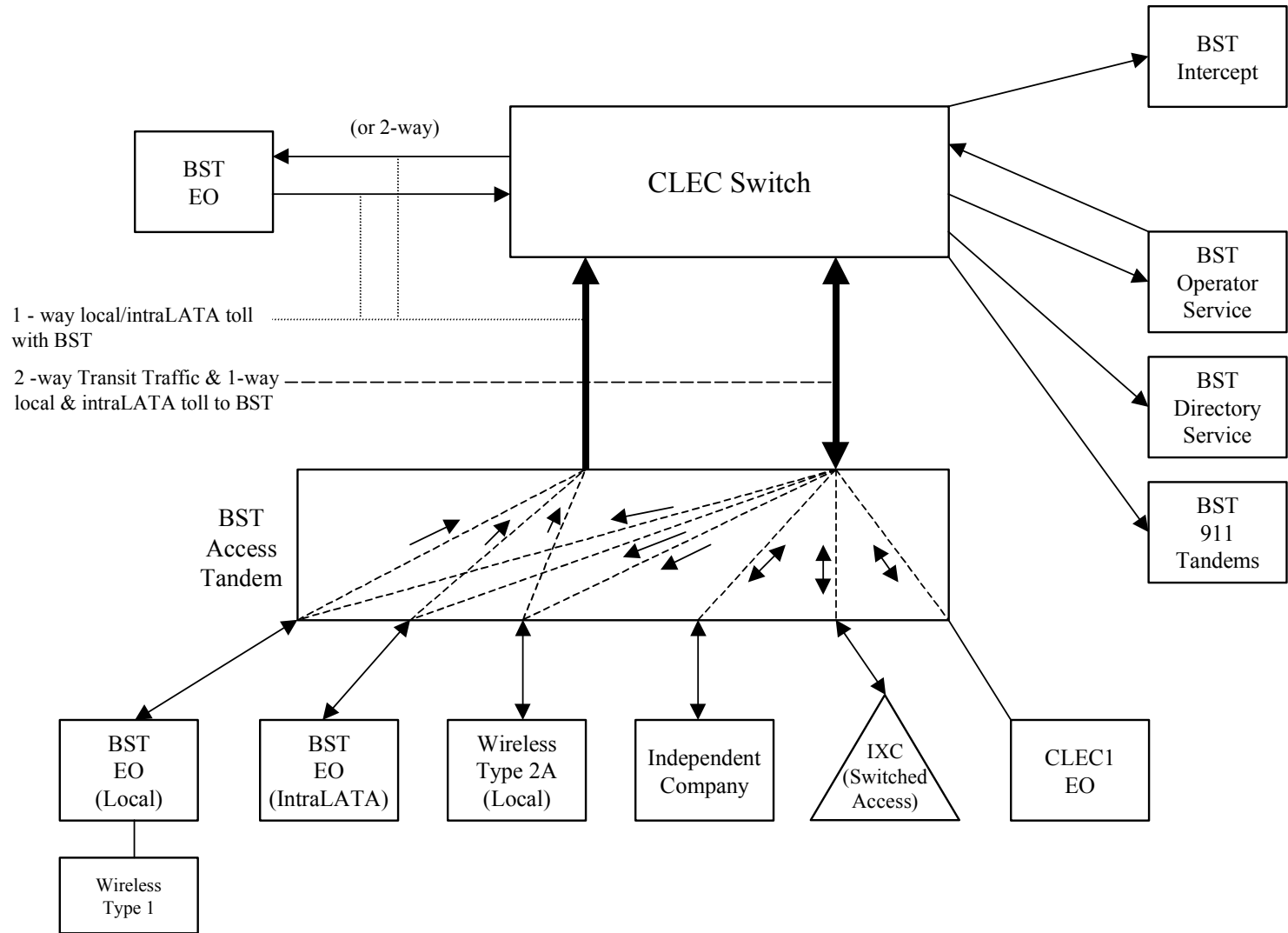

# One-Way Architecture

Exhibit C

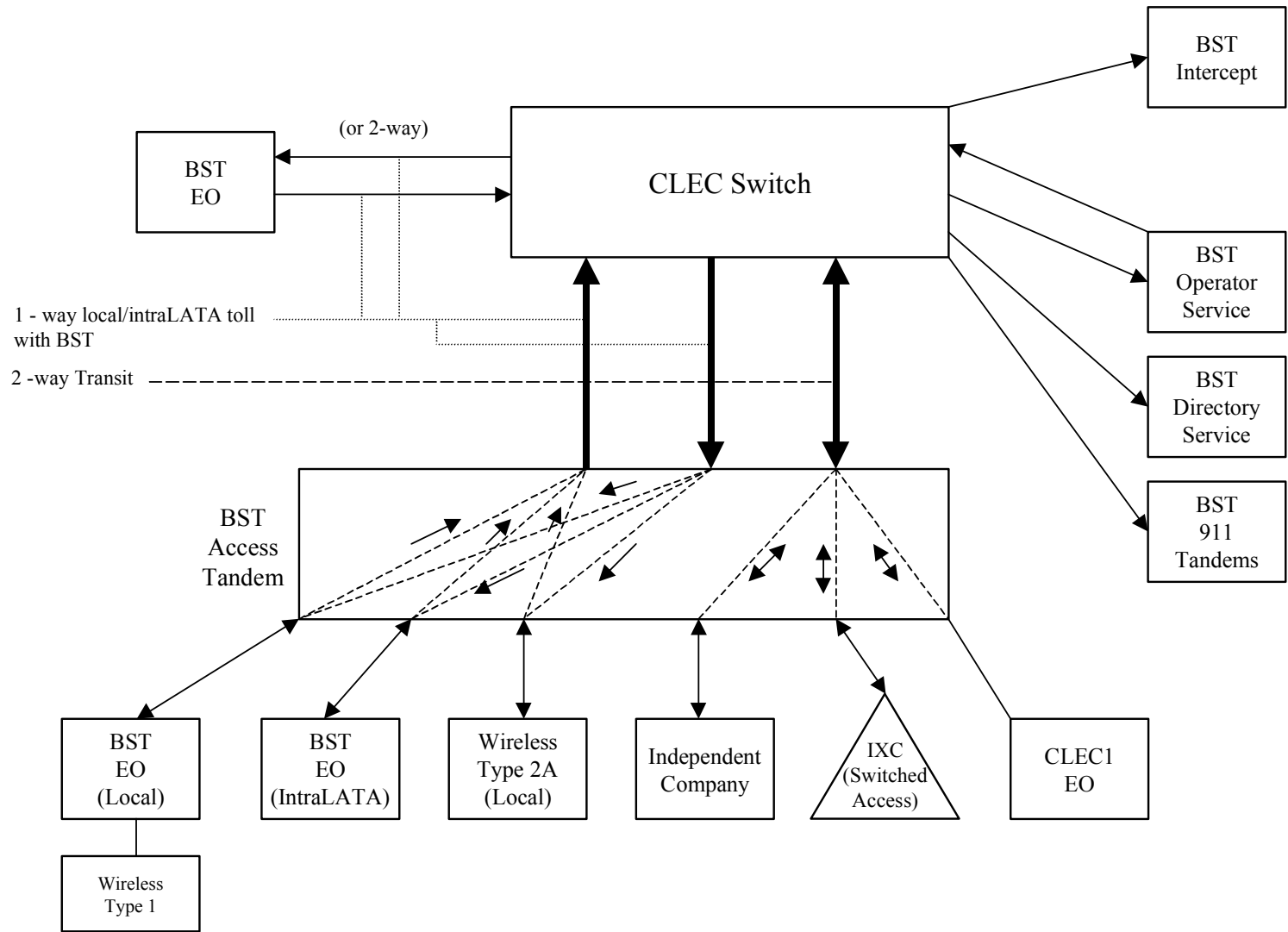



# Two-Way Architecture

Exhibit D

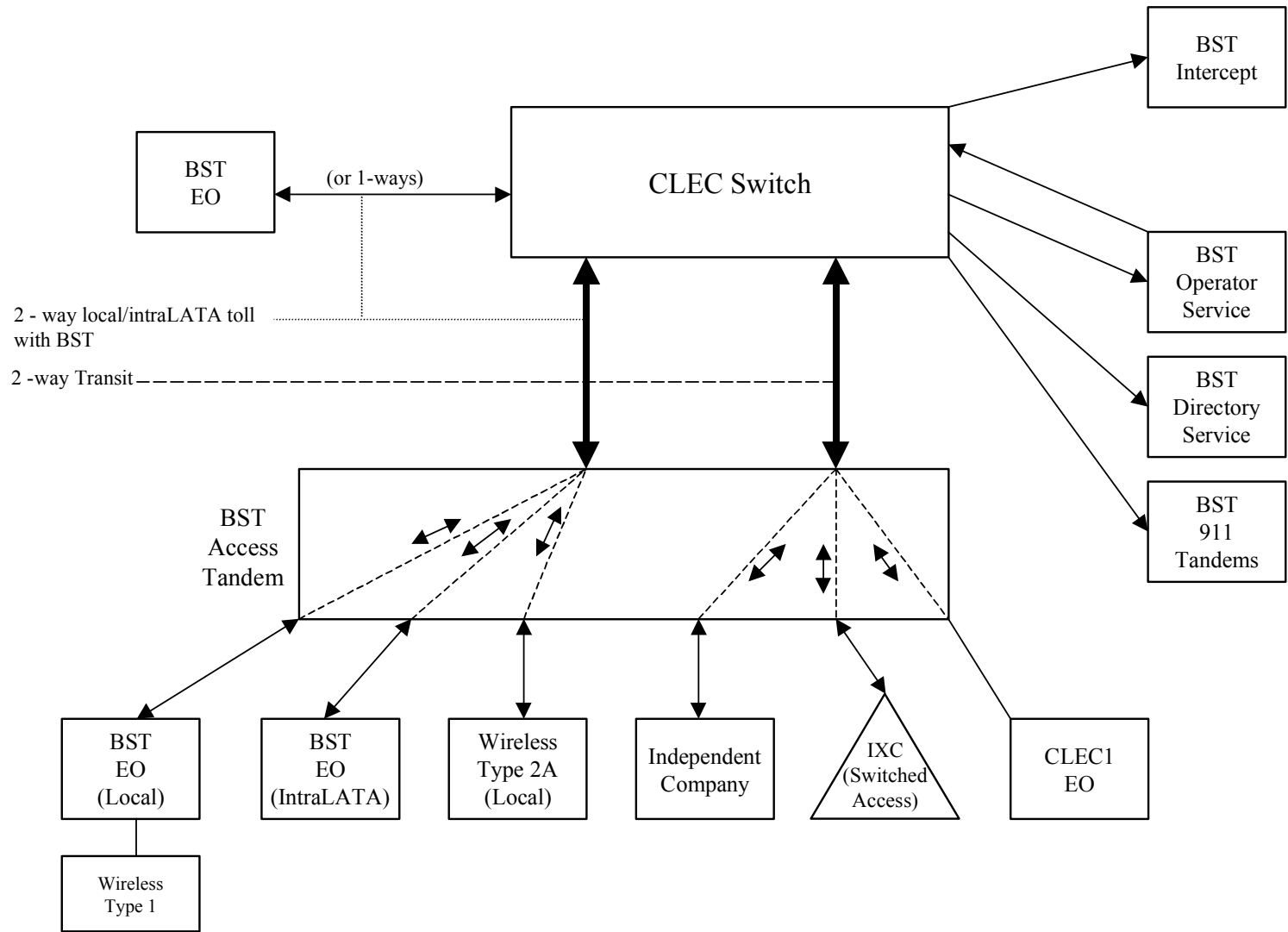

# Supergroup Architecture

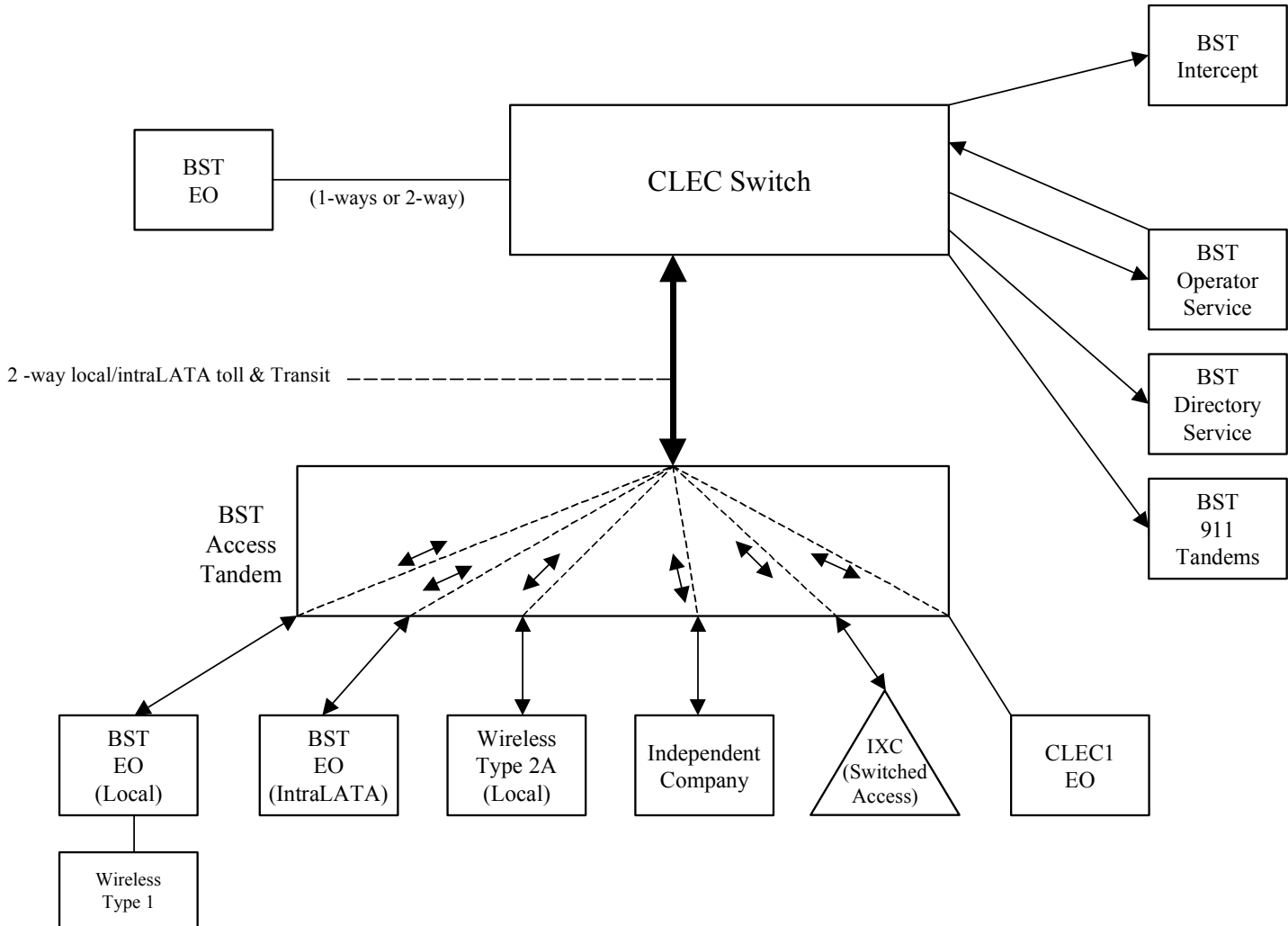



# **BellSouth Jurisdictional Factors Reporting Guide**

**Issue 5.0**

**December 3, 2003**

## Table of Contents

Revisions.....	3
1.0 Introduction.....	4
2.0 Jurisdictions.....	4
3.0 Factors.....	5
3.1 General.....	5
3.2 PIU - Percent Interstate Usage.....	6
3.3 PLU - Percent Local Usage.....	7
3.4 PLF - Percent Local Facility.....	7
4.0 Service Reporting Requirements.....	8
4.1 BellSouth Switched Access (SWA) Feature Group A (FGA) PIU (PIUA)...	8
4.2 BellSouth SWA FGB PIU (PIUB).....	9
4.3 BellSouth SWA FGD & Local Terminating PIU (TPIU).....	9
4.4 BellSouth Local Interconnection PLU.....	9
4.5 BellSouth SWA 500 PIU (ZP15).....	10
4.6 BellSouth SWA 700 Access Service (ZP17).....	10
4.7 BellSouth SWA 8XX Toll Free Dialing Ten Digit Screening (ZP18).....	10
4.8 BellSouth SWA 900 Service (ZP19).....	10
4.9 BellSouth SWA Transport PIUE.....	10
4.10 BellSouth Local Interconnection Transport PLF.....	11
4.11 BellSouth CCS7 Access Arrangements SPIU/SPLU.....	11
4.12 BellSouth Line Information Data Base Service LIDB.....	12
5.0 Report Process.....	12
6.0 Frequency of Reporting.....	13
7.0 Audits.....	14
7.1 Audit Request.....	14
7.2 Audit Compliance.....	14
8.0 Ordering.....	15

## **Revisions**

### **Issue 1.0**

The initial version of the *BellSouth Jurisdictional Factors Reporting Guide* was issued on August 15, 2001.

### **Issue 2.0**

Incorporated references to *RF-3995 Jurisdictional Factor Report Form* – issued on December 21, 2001.

### **Issue 3.0**

Added minor clarification concerning value to be used if PLF or PLU factors are not reported – issued on August 2, 2002.

### **Issue 4.0**

Added Clarification concerning reporting of SPIU Factor and added language describing SPLU Factor and calculation of intrastate of non-local traffic – issued on October 17, 2002.

### **Issue 5.0**

Revised the e-mail address that is utilized to report jurisdictional factors by electronic mail – issued on December 3, 2003.

## ***BellSouth Jurisdictional Factors Reporting Guide***

### **1.0 Introduction**

Jurisdictional factors are utilized to apportion the billing of BellSouth Access and Local Interconnections Services between the interstate, intrastate and local jurisdictions. The rates, terms and conditions applicable to the provision of services are determined based upon the jurisdictional use of the service. Where sufficient data is available BellSouth will determine the percentage of use by jurisdiction for billing applications in accordance with BellSouth tariffs and contractual agreements. Absent sufficient data it is incumbent upon BellSouth customers to accurately report jurisdictional factors in order for BellSouth to bill the associated services per contractual and regulatory requirements. This document serves as a supplemental guide to the BellSouth tariffs and contracts for the preparation and reporting of the following jurisdictional factors related to Access and Local Interconnection Services

PIU - Percent Interstate Usage

PLU - Percent Local Usage

PLF - Percent Local Facility

These factors are reported by service at a state level as required. Unique service requirements are identified later in this Guide. In general, the PIU factors are required for Access Services and Local Interconnection Services to apportion the billing between the state and interstate jurisdictions. Competitive Local Exchange Carriers (CLECs) are also required to report PLU and PLF factors in addition to PIU factors to further apportion their intrastate use of Local Interconnection services between the state and local jurisdiction. Failure to report values for PLU and/or PLF shall result in the default value of zero percent being applied for these factors. The local jurisdiction is considered a subset of the intrastate jurisdiction in the determination and application of the PLU and PLF factors. The following sections provide information concerning the determination of factors, the application of factors, reporting procedures and customer records requirements. This information is provided as an aide in reporting jurisdictional factors and shall be used as a supplement to BellSouth Tariffs and/or contractual agreements with BellSouth.

### **2.0 Jurisdictions**

There are three basic jurisdictions related to BellSouth Access and Local Interconnections Services. These are the Interstate, Intrastate and the Local jurisdiction. The jurisdiction is determined based upon the physical locations of the

origination and termination points of the communication. An ordinary voice communications telephone call that originates from a location that is in the same state

as the terminating number or called party shall be designated as an intrastate call and the minutes of use for that call shall be billed per the intrastate jurisdictional requirements. Conversely, a call that originates in a different state than the terminating location or called number shall be designated as interstate traffic. A call that originates and terminates within a local calling area as specified in the applicable contract or tariff is designated as local traffic.

The Jurisdiction of a call is determined solely by the location of the party initiating the call and the location of the called party. The origination and termination points are not necessarily determined based upon the carrier's network entry and exit points but rather on the origination and termination locations of the end users or the entities that are involved in the communications or information exchange. When multiple networks or carriers are involved, a particular carrier's transport of the service may be totally within a state boundary, however, the ultimate end points of the call or information exchange may be in different states. In this situation, the traffic shall be designated as interstate for all carriers even though a particular carrier's transport service begins and ends within a state boundary. In other words, jurisdiction of a call is determined solely by the locations of the originating and terminating parties and is not affected by the manner in which the call is routed through the telecommunications network.

The location of the origination or termination end points is determined based upon the location of the serving central offices. If a call terminates to an office that is associated with a LATA in an adjoining state (cross boundary) the call is considered to complete in the state where the central office is located.

## **3.0 Factors**

### **3.1. General**

BellSouth Jurisdictional factors are jurisdictional projections of the percentages of use of access and interconnection services for billing purposes. Factors shall be provided with the first request for each service in each state and are updated quarterly based upon the most recent three months of data. Factors for the initial request shall be reported via *RF-3995 Jurisdictional Factor Report* that is located at <http://www.interconnection.bellsouth.com/forms/index.html>, CLEC Forms Online or Interexchange Carrier Webforms. If factors are not updated then BellSouth will

assume that the percentages are the same as previously provided. If a valid quarterly report has never been received then BellSouth may utilize the factor(s) provided with the initial order for service, the most recent audit results if an audit has been performed or the default value for the particular factor. In cases where sufficient data is available then BellSouth will determine the factors to be utilized for billing.

### **3.2. PIU - Percent Interstate Usage**

This factor is the percentage of use that is interstate. For services that are billed on a per minute of use (MOU) basis the PIU is based upon the traffic to and from the BellSouth Network. Further, depending upon the type of usage based service, the PIU may represent the percentage of both originating and terminating usage or may only represent the percentage of terminating usage that is jurisdictionally interstate. Any traffic that originates/terminates in the reporting carrier's network that ultimately originates/terminates to the BellSouth Network through another carrier's network shall be included in the reported PIU factor(s) by the intermediate carrier that accepts billing for the usage. This relationship is usually established per an agency authorization. In these situations, the carrier that accepts billing from BellSouth for the usage to and from BellSouth shall include such usage in their factor calculations that are reported to BellSouth. Any usage that transits a reporting carrier's network shall be included in the jurisdictional factor reporting by the billed carrier to the originating/terminating carrier regardless of the number of carriers involved in the transport of the traffic. It is incumbent upon the carrier that is billed for originating/terminating traffic to the BellSouth Network to report PIU factors to BellSouth that are representative of the actual jurisdiction of traffic delivered to BellSouth.

For services that are not billed on a usage sensitive basis (e.g. Switched Transport Local Channel, Interoffice Channels & Multiplexing Equipment) the total use of the service shall be considered in determining the PIU factors including originating and terminating usage to the BellSouth Network.

The PIU factor is calculated as follows where MOUs are billed minutes of use:

$$\frac{\textit{Total Interstate MOUs}}{\textit{Total Usage MOUs}}$$

*Total Usage* includes interstate, intrastate and local usage. This percentage is calculated on a statewide basis. Both Interexchange Carriers and Facility Based Competitive Local Exchange Carriers (CLECs) are required to report PIU factors per their Access Carrier Name Abbreviation (ACNA).



### 3.3. PLU – Percent Local Usage

This factor is the percentage of intrastate terminating usage that is categorized as Local Jurisdiction. For purposes of this guide the total intrastate usage includes intrastate local usage and intrastate non-local usage. The local jurisdiction is applicable to Competitive Local Exchange Carriers (CLECs) that are terminating local traffic from their network to the BellSouth network. CLECs that totally utilize resale or unbundled network elements to provision local services are not required to report PLU factors. Interexchange Carriers that do not terminate local traffic as a CLEC are not required to report PLU factors. Terminating party pays usage shall be excluded from the PLU calculations (same as TPIU, Section 4.3). The local jurisdiction is normally defined per Local Interconnection contractual agreements and is calculated as follows where MOUs are billed minutes of use:

$$\frac{\textit{Total Local Terminating MOUs}}{\textit{Total Intrastate Terminating MOUs}}$$

The total intrastate terminating minutes can be determined by multiplying the total terminating minutes by (1- TPIU). Therefore the PLU may also be calculated as follows:

$$\frac{\textit{Total Local Terminating MOUs}}{(\textit{Total Terminating MOUs}) \times (1-\textit{TPIU})}$$

This factor is calculated on a statewide basis by Access Carrier Name Abbreviation (ACNA).

### 3.4. PLF – Percent Local Facility

The PLF is the percentage of the intrastate use of Switched Dedicated Transport and/or Local Interconnection Transport that is jurisdictionally local. This factor is similar to PLU except that it applies to dedicated transport services that are billed on a non-usage sensitive basis. Reporting of this factor is required by Facility Based CLECs utilizing BellSouth Local Interconnection transport services. Factors for the initial request shall be reported via *RF-3995 Jurisdictional Factor Report* (see <http://www.interconnection.bellsouth.com/forms/index.html>, CLEC Forms Online or Interexchange Carrier Webforms). In addition, IXCs that also function as a CLEC and utilize Switched Dedicated Transport and/or Local

Interconnection transport to interconnect with the BellSouth Network for the exchange of local traffic are required to report a PLF. As with PIU factors for non-usage sensitive billed services, the total use of these services are considered in determining the factor (i.e. all originating and terminating usage). The PLF represents the percentage of use of all the Switched Dedicated Transport and Local Interconnection Transport provisioned by BellSouth that is jurisdictionally local as defined per contract or tariff. The PLF for these services is based upon the usage that is transported by these services as follows:

$$\frac{\textit{Total Local MOUs}}{\textit{Total Intrastate MOUs}}$$

The total intrastate minutes can be determined by multiplying the total minutes by (1- PIUE) where PIUE is the factor applicable to Switched Dedicated Transports and Local Interconnection Transport. Therefore the PLF may also be calculated as follows:

$$\frac{\textit{Total Local Minutes}}{(\textit{Total Minutes}) \times (1-\textit{PIUE})}$$

This factor may is calculated on a statewide basis and reported per Access Carrier Name Abbreviation (ACNA).

## **4.0 Service Reporting Requirements**

Jurisdictional factors shall be developed and reported for particular services as specified in the BellSouth Tariffs and as specified in applicable contracts that are provisioned for a carrier. Factor reporting requirements for these services are discussed in the following subsections.

### **4.1. BellSouth Switched Access (SWA) Feature Group A (FGA) PIU (PIUA)**

Usage based rate elements are billed for FGA in both the originating and terminating directions. This usage shall be apportioned to the intrastate and interstate jurisdictions. A single PIU factor shall be reported at the state level to apportion all the applicable usage (both originating, terminating and transit) between the state and interstate jurisdictions. All usage received from or delivered to the BellSouth network and through the BellSouth Network to

connecting local exchange carriers shall be considered in the determination of the PIU for FGA.

#### **4.2. BellSouth SWA FGB PIU (PIUB)**

Usage based rate elements are billed for FGB in both the originating and terminating directions. This usage shall be apportioned to the state and interstate jurisdictions. A single PIU factor shall be reported at the state level to apportion all the applicable usage (both originating and terminating) based elements between the intrastate and interstate jurisdictions.

#### **4.3. BellSouth SWA FGD & Local Terminating PIU (TPIU)**

Usage based rate elements are billed for FGD in both the originating and terminating directions. BellSouth is able to determine the jurisdiction of originating FGD traffic per the billing records generated with each call. Therefore a factor to apportion usage for originating FGD traffic is not required from the reporting carrier. Originating traffic consists of calls where the location of the calling number is served from a BellSouth end office that is connecting to a carrier for completion to the called number location. The terminating usage shall be apportioned to the state and interstate jurisdictions per a TPIU factor. A single TPIU factor for terminating FGD traffic shall be reported at the state level to apportion the applicable usage based elements between the intrastate and interstate jurisdictions. Terminating party pays usage (e.g. 800 terminating traffic) shall be excluded from the TPIU calculations.

Local traffic shall also be included when determining the TPIU. If the reporting carrier functions as an Interexchange and Local carrier then all of the terminating usage sent to BellSouth will be apportioned between the state and interstate jurisdictions per a single TPIU. This factor shall be reported at the state level per Access Carrier Name Abbreviation (ACNA). A TPIU shall be reported by CLECs even if it does not terminate any interstate traffic to the BellSouth network. In this situation, the CLEC should report a TPIU equal to zero (0.00) to indicate that all of its traffic is Intrastate and Local.

#### **4.4. BellSouth Local Interconnection PLU**

The percent of usage to be billed per the Local Interconnection contracts is determined by the PLU factor. This factor shall be developed in conjunction with the TPIU factor discussed in the previous subsection. After the TPIU is

determined then the percentage of the intrastate usage that is local shall be determined. By definition, the percentage of intrastate traffic of the total terminating traffic is equal to  $1 - \text{TPIU}$ . The total terminating traffic to be considered is discussed in the TPIU subsection. The PLU represents the percentage of intrastate terminating usage that is jurisdictionally local. This factor is reported at the state level by ACNA.

#### **4.5. BellSouth SWA 500 PIU (ZP15)**

The SWA 500 PIU factor will be applied to the carrier's originating 500 service MOUS and to the calls to apportion the usage and calls between state and interstate jurisdiction. This factor represents the percentage of originating 500 minutes and calls that are interstate jurisdiction.

#### **4.6. BellSouth SWA 700 Access Service (ZP17)**

The SWA 700 PIU factor will be applied to the carrier's originating 700 service MOUS to apportion the usage between state and interstate jurisdiction. This factor represents the percentage of originating 700 minutes that are interstate jurisdiction.

#### **4.7. BellSouth SWA 8XX Toll Free Dialing Ten Digit Screening (ZP18)**

The SWA 8XX PIU factor will be applied to the carrier's originating 8XX service MOUS and queries to apportion the usage and queries between the intrastate and interstate jurisdiction. This factor represents the percentage of originating 8XX minutes and queries that are interstate jurisdiction.

#### **4.8. BellSouth SWA 900 Service (ZP19)**

The SWA 900 PIU factor will be applied to the carrier's originating 900 service MOUS to apportion the usage between the intrastate and interstate jurisdiction. This factor represents the percentage of originating 900 minutes that are interstate jurisdiction.

#### **4.9. BellSouth SWA Transport PIUE**

BellSouth SWA Transport PIUE is applicable to the following SWA Transport Services:

- SWA Local Channel
- SWA Dedicated Interoffice Channels
- SWA Channelization Equipment
- Local Interconnection Dedicated Transport
- Dedicated End Office Trunk Port Service
- Dedicated Tandem End Office Trunk Port Service
- SWA Expanded Interconnection Cross-Connects

The PIUE may also be applied to other flat rated charges not specifically covered by other PIU categories.

The utilization of these transport services is considered in combination to determine the PIUE factors. The PIUE will be applied to the recurring billing elements for these services to apportion billing between the intrastate and interstate jurisdictions. The total jurisdictional use of these services shall be considered when determining PIUE factors including all originating and terminating usage. The PIUE represents the percentage that these services are utilized for interstate jurisdiction applications.

#### **4.10. BellSouth Local Interconnection Transport PLF**

This factor is utilized to apportion the use of SWA Local Channel, SWA Dedicated Interoffice Channels, SWA Channelization Equipment, Local Interconnection Dedicated Transport, Tandem/End Office Ports and various other flat rated services to the Local Jurisdiction for billing purposes (per tariff and contractual agreements). This factor is developed in conjunction with the PIUE. The PLF represents the percentage of the Intrastate use of these services that is jurisdictionally Local whereby the Intrastate percentage is defined as 1-PIUE. The total jurisdictional use of these services shall be considered when determining PLF and should include originating and terminating traffic. This factor is reported at the state level by ACNA.

#### **4.11.a. BellSouth CCS7 Access Arrangement SPIU**

If a carrier has access to CCS7 Signaling Services monitoring software, then that carrier may use this software to identify the appropriate jurisdictional factors (SPIU/SPLU) on its signaling with BellSouth and report these factors in the same format detailed herein.

If, however, a carrier does not have access to CCS7 Signaling Services monitoring software, then as APIU for CCS7 Signaling Services shall be developed and reported based upon the associated billed minutes of use for SWA

Usage- based services. The billed minutes that are jurisdictionally *interstate* as a percentage of the total billed minutes shall be reported as the CCS7 Access SPIU.

**4.11.a. BellSouth CCS7 Access Arrangement SPLU**

If a carrier has access to CCS7 Signaling Services monitoring software, then that carrier may use this software to identify the appropriate jurisdictional factors (SPIU/SPLU) on its signaling with BellSouth and report these factors in the same format detailed herein.

If, however, a carrier does not have access to CCS7 Signaling Services monitoring software, then an SPLU for CCS7 Signaling Services shall be developed and reported based upon the associated billed minutes of use for SWA Usage based services and Local Interconnection services. The billed minutes that are jurisdictionally *local* as a percentage of the total *intrastate* billed minutes shall be reported as the CCS7 Access SPLU. Where the customer is a “Third Party Provider” of CCS7 Access services then the SPLU will be developed based upon a weighted average of all of that provider’s “Third Party Customer’s” end user traffic.

**4.11.c. BellSouth CCS7 Access Arrangement: Special Note**

In determining a factor for intrastate, *non-local traffic*, consider the following example:

Based on evaluating SWA usage-based services and local interconnection services, a BellSouth carrier customer has determined that its signaling traffic merits an SPIU of 80 and an SPLU of 60. As such, the following will then be true:

**80%** of the carrier’s signaling messages will be billed as *interstate*.  
Of the remaining **20%**, 60% of the 20% ( $.60 \times .20 = .12$ ), **12%** will be billed as *local*.

And, the final **8%** will be billed as *intrastate, non-local*.

**5. BellSouth Line Information Data Base Service LIDB**

There are two factors reported for LIDB service, a PIU factor and a PCLU (Percent CLEC LIDB Usage). These factors are utilized to apportion the queries

to the LIDB Data Base between the interstate, intrastate and local jurisdiction. First, the total number of queries in the study period is determined and then the PCLU shall be calculated. The PCLU represents the percentage of LIDB queries that are jurisdictionally Local as a percentage of the total number of queries. The basic formula for the PCLU calculation is as follows:

$$\frac{\text{Number of Local Queries}}{\text{Total Number of Queries}}$$

After the PCLU is determined, the LIDB PIU shall be determined. The LIDB PIU represents the percentage of queries that are jurisdictionally interstate of the total number of queries minus the number of queries that are jurisdictionally local. The formula for the LIDB PIU is as follows:

$$\frac{\text{Number of Interstate Queries}}{(\text{Total Number of Queries}) - (\text{Number of Local Queries})}$$

## 5.0 Report Process

The following summarizes the major steps to develop and report jurisdictional factors:

- Install/modify systems to capture usage data with sufficient detail to accurately determine and aggregate the usage to the appropriate jurisdiction, by ACNA
- Create/Modify call detail records for traffic segregation to the appropriate service and jurisdiction
- Record and accumulate usage data
- Analyze usage data
- Calculate the factors
- Report the factors
- Maintain sufficient records of the data resources utilized to determine jurisdictional factors to comply with audit verification requirements as specified in the BellSouth Tariffs and applicable contractual agreements.

## 6.0 Frequency of Reporting

Jurisdictional factors shall be updated on a quarterly basis during the months of January, April, July and October. These updates shall be received no later than 30

days after the first day in each of these months. These factors shall represent the actual use for the three previous ending on the last day of December, March, June and September respectively. These updates shall be provided in writing by letter or electronic mail and sent to the following address:

US Mail

BellSouth Telecommunications, Inc  
2300 Northlake Centre Drive  
Suite 415  
Tucker, GA 30084

OR

Electronic Mail

piu.reports@bellsouth.com

An e-mail will be returned indicating receipt of reports submitted by electronic mail. The recommended format for updates is via the online form *RF-3995 Jurisdictional Factor Report* (see <http://www.interconnection.bellsouth.com/forms/index.html>, CLEC Forms Online or Interexchange Carrier Webforms).

In those instances where BellSouth has sufficient information to calculate jurisdictional factors for itself, BellSouth will notify the carrier, by letter or email, of the factors that will be used in billing, as well as the effective date. Unless otherwise notified, BellSouth will continue to update the specific identified factor(s) for subsequent quarters per the above schedule and the carrier will be exempt from further responsibility to report those specific factors.

In the event the customer does not provide a projected jurisdictional factor(s) and BellSouth does not have sufficient information to develop the jurisdictional factor(s) then BellSouth may utilize the most recent audit results if an audit has been performed, the jurisdictional factor(s) provided with the initial order for service or a default value.

## **7.0 Audits**

### **7.1. Audit Request**



If BellSouth disputes a PIU factor provided by a carrier and BellSouth does not have sufficient information to calculate a PIU, BellSouth may initiate negotiations with the carrier in order to reconcile the factor differences and attempt to determine the correct PIU factor.

If negotiations are attempted and are not successful in producing an agreed PIU factor, BellSouth has the option per its access tariffs to initiate an independent, third party audit of the carrier's PIU factors and the process utilized in the development of PIU factors.

Upon 30 days written notice, BellSouth may initiate an audit to ensure proper billing of traffic. The audit will be performed by:

- An independent auditor under contract to BellSouth
- A mutually acceptable independent auditor paid for by BellSouth
- Or an independent auditor selected and paid for by the carrier

Call detail records from which the PIU can be ascertained shall be retained for a minimum of 6 months. The call detail records will be made available for inspection at an agreed upon location during normal business hours. If requested data is not provided within 30 days of the notice, the carrier shall be in violation of the Tariff. BellSouth will not submit more than one audit request per calendar year.

## **7.2. Audit Compliance**

The factor shall be adjusted based upon the audit results. The audited factor shall be applied to the usage for the quarter the audit was completed, the quarter prior to the audit, and the two quarters following the completion of the audit. If the audited factor has a variance of 20% or more from the factor reported factor, the carrier shall reimburse BellSouth for the cost of the audit if the audit was paid for by BellSouth.

Two quarters after the quarter in which the audit was completed, the carrier may report a revised factor. If the revised factor denotes a deviation of 5% or more from the audited factor and the carrier is not able to justify this deviation to BellSouth's satisfaction, BellSouth has the option of requesting another audit.

The carrier may contest the audit within 30 days from the date the audit report has been furnished to the carrier.

## 8.0 Ordering

As stated in 3.1 preceding, BellSouth jurisdictional shall be provided with the initial request for each service in each state and quarterly thereafter. Factors for the initial request shall be reported via *RF-3995 Jurisdictional Factor Report* which is located at <http://www.interconnection.bellsouth.com/forms/index.html>, CLEC Forms Online or Interexchange Carrier Webforms. Failure to provide the appropriate factors with the initial request may result in delay of service. In the event that service is provided and the appropriate factors have not been received, a default factor may be used.

## **Attachment 4**

### **Collocation**

## BELLSOUTH COLLOCATION

### 1. Scope of Attachment

- 1.1 The rates, terms, and conditions contained within this Attachment shall only apply when <<customer\_short\_name>> is collocated as a sole occupant or as a Host within a BellSouth premises location pursuant to this Attachment. BellSouth premises include BellSouth Central Offices and Serving Wire Centers; all buildings or similar structures owned, leased, or otherwise controlled by BellSouth that house its network facilities; all structures that house BellSouth facilities on public rights-of-ways, including but not limited to vaults containing loop concentrators or similar structures; and all land owned, leased, or otherwise controlled by BellSouth that is adjacent to BellSouth's Central Offices, Serving Wire Centers, buildings and structures (hereinafter "Premises"). BellSouth Remote Site Locations ("Remote Site Locations") include cabinets, huts and controlled environmental vaults owned or leased by BellSouth that house BellSouth Network Facilities. If the Premises occupied by BellSouth is leased by BellSouth from a third party or otherwise controlled by a third party, special considerations and/or intervals may apply in addition to the terms and conditions contained in this Attachment. BellSouth will inform <<customer\_short\_name>> if a Premises is leased when special considerations and/or intervals may be applicable.
- 1.2 If BellSouth provides collocation to other telecommunications carriers, or to a BellSouth Affiliate, BellSouth will provide the same collocation to <<customer\_short\_name>> at rates, terms and conditions no less favorable to <<customer\_short\_name>> than those provided by BellSouth to other telecommunications carriers, or to a BellSouth Affiliate.
- 1.3 Right to Occupy. BellSouth shall offer to <<customer\_short\_name>> collocation on rates, terms, and conditions that are just, reasonable, non-discriminatory and in full compliance with the rules and orders of the FCC and the Commission. Subject to the rates, terms and conditions of this Attachment, where space is available and it is technically feasible, BellSouth will allow <<customer\_short\_name>> to occupy a certain area designated by BellSouth within a Premises or on BellSouth property upon which the Premises is located of a size which is specified by <<customer\_short\_name>> and agreed to by BellSouth (hereinafter "Collocation Space", or "Remote Site Collocation Space"). To the extent not contained herein, the necessary rates, terms and conditions for collocation at Premises, as defined by the FCC above, shall be negotiated upon reasonable request for collocation at such Premises.
- 1.4 Space Reservation.

- 1.4.1 Neither BellSouth nor any of BellSouth's Affiliates may reserve space for future use on more preferential terms than those set forth in Sections 1.4.2 and 1.4.3 of this Attachment.
- 1.4.2 In all states other than Florida, the size, or rack/bay(s) in a Remote Site Location, specified by <<customer\_short\_name>> may contemplate a request for space sufficient to accommodate <<customer\_short\_name>>'s growth within a twenty-four (24) month period.
- 1.4.3 In the state of Florida, the size, or rack/bay(s) in a Remote Site Location, specified by <<customer\_short\_name>> may contemplate a request for space sufficient to accommodate <<customer\_short\_name>>'s growth within an eighteen (18) month period.
- 1.5 Space Allocation. BellSouth shall use best efforts to accommodate <<customer\_short\_name>>'s requested preferences, if any, including the provision of contiguous space for any subsequent request for collocation. In allocating Collocation Space, BellSouth shall not (a) materially increase <<customer\_short\_name>>'s cost or materially delay <<customer\_short\_name>>'s occupation and use of the Collocation Space, (b) assign Collocation Space that will impair the quality of service or otherwise limit the service <<customer\_short\_name>> wishes to offer, (c) reduce unreasonably the total space available for physical collocation at a Premise, or preclude unreasonably physical collocation within the Premises. Consistent with the foregoing, BellSouth shall assign <<customer\_short\_name>> collocation space within Premises that utilizes existing infrastructure (e.g., HVAC, lighting and available power), if such space is available for collocation. Space shall not be available for collocation if it is: (a) physically occupied by non-obsolete equipment; (b) assigned to another collocated telecommunications carrier; (c) used to provide physical access to occupied space; (d) used to enable technicians to work on equipment located within occupied space; (e) properly reserved for future use, either by BellSouth or another collocated telecommunications carrier; or (f) essential for the administration and proper functioning of Premises. BellSouth may segregate Collocation Space and require separate entrances for collocated telecommunications carriers to access their Collocation Space, pursuant to FCC Rules.
- 1.6 Space Reclamation. In the event of space exhaust within a Premises, BellSouth may include in its documentation for the Petition for Waiver filed with the Commission, any unutilized space in the Premises. <<customer\_short\_name>> will be responsible for the justification of unutilized space within its Collocation Space, if the Commission requires such justification.
- 1.7 Virtual Collocation Space Reservation. BellSouth shall relinquish any space held for future use before denying a request for virtual collocation on the grounds of space limitations, unless BellSouth proves to the Commission that virtual collocation at that point is not technically feasible.

- 1.8 Use of Space. <<customer\_short\_name>> shall use the Collocation Space for the purposes of installing, maintaining and operating <<customer\_short\_name>>'s equipment (to include testing and monitoring equipment) necessary for interconnection or for accessing unbundled network elements in accordance with the Act and FCC and Commission rules.
- 1.9 The Parties agree to comply with all applicable federal, state, county, local and administrative laws, rules, ordinances, regulations and codes in the performance of their obligations.
- 1.10 Service Coordination. The Parties shall coordinate, where necessary, to ensure that the Collocation Space is provisioned in accordance with the specifications submitted by <<customer\_short\_name>> in its Application, as affirmed by the Bona Fide Firm Order ("BFFO") or as jointly amended thereafter. BellSouth will provide the necessary infrastructure to support <<customer\_short\_name>>'s request(s) pursuant to this Agreement.

## **2. Space Availability Report**

- 2.1 Upon request from <<customer\_short\_name>> and at the <<customer\_short\_name>>'s expense, BellSouth will provide a written report (Space Availability Report) describing in detail the space that is available for collocation at a particular Premises. This report will include the amount of Collocation Space available at the Premises requested, the number of collocators present at the Premises, any modifications in the use of the space since the last report on the Premises requested and the measures BellSouth is taking to make additional space available for collocation arrangements. A Space Availability Report does not reserve space at the Premises for which the Space Availability Report was requested by <<customer\_short\_name>>.
- 2.1.1 The request from <<customer\_short\_name>> for a Space Availability Report must be in writing and include the Premises street address, as identified in the Local Exchange Routing Guide (LERG) and Common Language Location Identification (CLLI) code of the Premises. CLLI code information is located in the National Exchange Carrier Association (NECA) Tariff FCC No. 4.
- 2.1.1.1 If <<customer\_short\_name>> is unable to obtain the CLLI code for the Remote Site Location from, for example, a site visit to the remote site, <<customer\_short\_name>> may request the CLLI code from BellSouth. To obtain a CLLI code for a Remote Site Location directly from BellSouth, <<customer\_short\_name>> should submit to BellSouth a Remote Site Interconnection Request (the Request) for the Serving Wire Center CLLI code prior to submitting its request for a Space Availability Report. <<customer\_short\_name>> should complete all the requested information and submit the Request to BellSouth. BellSouth will bill the applicable fee as set forth in Exhibit B of this Attachment.

- 2.1.2 BellSouth will respond to a request for a Space Availability Report for a particular Premises within ten (10) calendar days of the receipt of such a request. If BellSouth cannot meet the ten (10) calendar day response time, BellSouth shall notify <<customer\_short\_name>> and inform <<customer\_short\_name>> of the timeframe under which it can respond.
- 2.2 Remote Site Information. Upon written request, BellSouth will provide <<customer\_short\_name>> with the following information concerning BellSouth's remote sites: (i) the address of the remote site; (ii) the CLLI code of the remote site; (iii) the carrier serving area of the remote site; (iv) the designation of which remote sites subtend a particular central office; and (v) the number and address of customers that are served by a particular remote site.
- 2.3 BellSouth will provide this information on a first come, first served basis within thirty (30) calendar days of <<customer\_short\_name>>'s request subject to the following conditions: (i) the information will only be provided on a CD in the same format in which it appears in BellSouth's systems; (ii) the information will only be provided for each serving wire center designated by <<customer\_short\_name>>, up to a maximum of thirty (30) wire centers per <<customer\_short\_name>> request per month per state, and up to a maximum of one hundred twenty (120) wire centers total per month per state for all CLECs; and (iii) <<customer\_short\_name>> agrees to pay the cost as set forth in Exhibit B.

### **3. Collocation Options**

- 3.1 Cageless. BellSouth shall allow <<customer\_short\_name>> to collocate <<customer\_short\_name>>'s equipment and facilities without requiring the construction of a cage or similar structure. BellSouth shall allow <<customer\_short\_name>> to have direct access to <<customer\_short\_name>>'s equipment and facilities in accordance with Section 5.19 below. BellSouth shall make cageless collocation available in single rack/ bay increments. Except where <<customer\_short\_name>>'s equipment requires special technical considerations (e.g., special cable racking or isolated ground plane), BellSouth shall assign cageless Collocation Space in conventional equipment rack lineups where feasible. For equipment requiring special technical considerations, <<customer\_short\_name>> must provide the equipment layout, including spatial dimensions for such equipment pursuant to generic requirements contained in Telcordia GR-63-Core, and shall be responsible for compliance with all special technical requirements associated with such equipment.
- 3.2 Caged. BellSouth will make caged collocation available in fifty (50) square foot increments, which should be sufficient enough, to collocate a single rack/bay of equipment. At <<customer\_short\_name>>'s expense, <<customer\_short\_name>> will arrange with a Supplier certified by BellSouth (BellSouth Certified Supplier) to construct a collocation arrangement enclosure in accordance with BellSouth's reasonable and nondiscriminatory Technical References (TRs) (Specifications), where technically feasible as that term has been defined by the FCC, prior to starting

equipment installation. BellSouth will provide Specifications to its BellSouth Certified Suppliers. Where local building codes require enclosure specifications more stringent than BellSouth's enclosure Specifications, <<customer\_short\_name>> and <<customer\_short\_name>>'s BellSouth Certified Supplier must comply with the more stringent local building code requirements. <<customer\_short\_name>>'s BellSouth Certified Supplier shall be responsible for filing and receiving any and all necessary permits and/or licenses for such construction. BellSouth shall cooperate with <<customer\_short\_name>> and provide, at <<customer\_short\_name>>'s expense, the documentation, including existing building architectural drawings, enclosure drawings, and Specifications required and necessary for <<customer\_short\_name>>'s BellSouth Certified Supplier to obtain the zoning, permits and/or other licenses. <<customer\_short\_name>>'s BellSouth Certified Supplier shall bill <<customer\_short\_name>> directly for all work performed for <<customer\_short\_name>> pursuant to this Attachment. BellSouth shall have no liability for, nor responsibility to pay, such charges imposed by <<customer\_short\_name>>'s BellSouth Certified Supplier. Upon request, BellSouth shall construct the enclosure for <<customer\_short\_name>>.

- 3.2.1 BellSouth may elect to review <<customer\_short\_name>>'s plans and specifications prior to allowing construction to start, to ensure compliance with BellSouth's Specifications. BellSouth will notify <<customer\_short\_name>> of its desire to execute this review in BellSouth's response to the Initial Application, if <<customer\_short\_name>> has indicated its desire to construct its own enclosure. If <<customer\_short\_name>>'s Initial Application does not indicate its desire to construct its own enclosure, but its subsequent firm order does indicate its desire to construct its own enclosure, then notification to review will be given within ten (10) calendar days after the Firm Order date. BellSouth shall complete its review within fifteen (15) calendar days after the receipt of <<customer\_short\_name>>'s plans and specifications. Regardless of whether or not BellSouth elects to review <<customer\_short\_name>>'s plans and specifications, BellSouth reserves the right to inspect the enclosure after construction has been completed to ensure that it is constructed according to <<customer\_short\_name>>'s submitted plans and specifications and/or BellSouth's Specifications, as applicable. If BellSouth decides to inspect the constructed Collocation Space, BellSouth will complete its inspection within fifteen (15) calendar days after receipt of written notification of completion of the enclosure from <<customer\_short\_name>>. BellSouth may require <<customer\_short\_name>> to remove or correct within seven (7) calendar days, at <<customer\_short\_name>>'s expense, any structure that materially deviates from <<customer\_short\_name>>'s plans and specifications or BellSouth's Specifications, if applicable. If <<customer\_short\_name>> requests BellSouth to construct the enclosure or do any other work, <<customer\_short\_name>> reserves the right to inspect the enclosure or work performed by BellSouth and review any plans or specifications related to the same.

- 3.3 Shared Caged Collocation. <<customer\_short\_name>> may allow other telecommunications carriers to share <<customer\_short\_name>>'s caged collocation arrangement, where technically feasible as that term has been defined by the FCC,



- pursuant to the terms and conditions agreed to by <<customer\_short\_name>> (Host) and the other telecommunications carriers (Guests) pursuant to this Section, except where the Premises is located within a leased space and BellSouth is prohibited by said lease from offering such an option to <<customer\_short\_name>> or is located on property for which BellSouth holds an easement and such easement does not permit such an option for a Remote Site Location. BellSouth shall be notified in writing by <<customer\_short\_name>> upon the execution of any agreement between the Host and its Guest(s) prior to the submission of any application. Further, such notification shall include the name of the Guest(s), the term of the agreement, and a certification by <<customer\_short\_name>> that said agreement imposes upon the Guest(s) the same terms and conditions for Collocation Space as set forth in this Attachment between BellSouth and <<customer\_short\_name>>.
- 3.3.1 <<customer\_short\_name>>, as the Host, shall be the sole interface and responsible Party to BellSouth for the assessment and billing of rates and charges contained within this Attachment and for the purposes of ensuring that the safety and security requirements of this Attachment are fully complied with by the Guest(s), its employees and agents. BellSouth shall provide <<customer\_short\_name>> with a proration of the costs of the Collocation Space based on the number of collocators and the space used by each. BellSouth will not allocate less than one (1) rack/bay per Host/Guest. In those instances where the Host permits a Guest to use a shelf within the Host's bay within a Remote Site Location, BellSouth will not prorate the cost of the bay. In all other states than Florida, and in addition to the above, <<customer\_short\_name>> shall be the responsible party to BellSouth for the purpose of submitting applications for initial and additional equipment placement for the Guest(s). In Florida, the Guest(s) may submit its own initial and additional equipment placement applications using the Host's Access Carrier Name Abbreviation (ACNA), provided that Guest secures permission from <<customer\_short\_name>> to use <<customer\_short\_name>>'s ACNA and password. A separate Guest application shall result in the assessment of a Remote Site Application Fee, an Initial Application Fee or a Subsequent Application Fee, as set forth in Exhibit B, which will be billed to the Host on the date that BellSouth provides its written response to the Guest(s) Bona Fide Application (Application Response).
- 3.3.2 Notwithstanding the foregoing, the Guest(s) may submit service orders directly to BellSouth to request the provisioning of interconnecting facilities between BellSouth and the Guest(s), the provisioning of services, and access to unbundled network elements. The bill for these interconnecting facilities, services and access to UNEs will be charged to the Guest(s) pursuant to the applicable Tariff or the Guest's Interconnection Agreement with BellSouth.
- 3.3.3 <<customer\_short\_name>> shall indemnify and hold harmless BellSouth from any and all claims, actions, causes of action, of whatever kind or nature arising out of the presence of <<customer\_short\_name>>'s Guest(s) in the Collocation Space, except to the extent caused by BellSouth's, its employees' or agents' negligence, gross negligence, or willful misconduct.

- 3.3.4 In making shared caged arrangements available, whether or not <<customer\_short\_name>> serves as Host, BellSouth may not increase the cost of site preparation or nonrecurring charges above the cost of provisioning such a shared arrangement of similar dimensions and material to a single collocating party.
- 3.4 Shared Remote Site Cageless Collocation. Subject to the requirements set forth in Section 3.3 above, to the extent BellSouth is permitted to offer shared collocation at Remote Site locations by property or easement owners, BellSouth will permit shared cageless collocation at such locations, where technically feasible, and space is available.
- 3.5 Adjacent Collocation. Subject to technical feasibility and space availability, BellSouth will permit an adjacent collocation arrangement (Adjacent Arrangement) on Premises' property only when space within the Premises is legitimately exhausted and where the Adjacent Arrangement does not interfere with access to existing or planned structures or facilities on the Premises' property. An Adjacent Arrangement shall be constructed or procured by <<customer\_short\_name>> and must be in conformance with reasonable and nondiscriminatory provisions of BellSouth's design and construction Specifications. Further, <<customer\_short\_name>> shall construct, procure, maintain and operate said Adjacent Arrangement(s) pursuant to all of the applicable rates, terms and conditions set forth in this Attachment. Additional rates, where applicable, shall be negotiated at the time of the application for the Remote Site Adjacent Arrangement.
- 3.5.1 If <<customer\_short\_name>> requests Adjacent Collocation, pursuant to the conditions stated in Section 3.5 above, <<customer\_short\_name>> must arrange with a BellSouth Certified Supplier to construct the Adjacent Arrangement structure in accordance with BellSouth's Specifications. BellSouth will provide Specifications upon request. Where local building codes require enclosure specifications more stringent than BellSouth's Specifications, <<customer\_short\_name>> and <<customer\_short\_name>>'s BellSouth Certified Supplier must comply with the more stringent local building code requirements. <<customer\_short\_name>>'s BellSouth Certified Supplier shall be responsible for filing and receiving any and all necessary zoning, permits and/or licenses for such construction. <<customer\_short\_name>>'s BellSouth Certified Supplier shall bill <<customer\_short\_name>> directly for all work performed for <<customer\_short\_name>> pursuant to this Attachment. BellSouth shall have no liability for, nor responsibility to pay, such charges imposed by <<customer\_short\_name>>'s BellSouth Certified Supplier.
- 3.5.2 <<customer\_short\_name>> must submit its Adjacent Arrangement construction plans and specifications to BellSouth when it places its Firm Order. BellSouth shall review <<customer\_short\_name>>'s plans and specifications prior to construction of an Adjacent Arrangement(s) to ensure <<customer\_short\_name>>'s compliance with BellSouth's Specifications. BellSouth shall complete its review within fifteen (15) calendar days after receipt of the plans and specifications from

- <<customer\_short\_name>> for the Adjacent Arrangement. BellSouth may inspect the Adjacent Arrangement during and after construction is completed to ensure that it is constructed according to <<customer\_short\_name>>'s submitted plans and specifications. If BellSouth decides to inspect the completed Adjacent Arrangement, BellSouth will complete its inspection within fifteen (15) calendar days after receipt of written notification of completion of the enclosure from <<customer\_short\_name>>. BellSouth may require <<customer\_short\_name>> to remove or correct within seven (7) calendar days at <<customer\_short\_name>>'s expense, any structure that materially deviates from its submitted plans and specifications or BellSouth's Specifications, if applicable.
- 3.5.3 <<customer\_short\_name>> shall provide a concrete pad, the structure housing the arrangement, heating/ventilation/air conditioning (HVAC), lighting, and all of the facilities that are required to connect the structure (i.e., racking, conduits, etc.) to the BellSouth point of demarcation. At <<customer\_short\_name>>'s option, and where the local authority having jurisdiction permits, BellSouth shall provide an AC power source and access to physical collocation services and facilities, subject to the same nondiscriminatory requirements as those applicable to any other physical collocation arrangement. In Alabama and Louisiana, BellSouth will provide DC power, to Adjacent Collocation sites where technically feasible, as that term has been defined by the FCC subject to individual case basis pricing that complies with the pricing standards of Sections 251 and 252 of the Act. <<customer\_short\_name>>'s BellSouth Certified Supplier shall be responsible, at <<customer\_short\_name>>'s sole expense, for filing and receiving any and all necessary zoning, permits and/or licenses for an Adjacent Arrangement. BellSouth shall allow shared use of the Adjacent Arrangement pursuant to the terms and conditions set forth in Section 3.4 above.
- 3.5.4 In the event that interior space in a BellSouth Premises becomes available, and subject to the provisions of Section 6.6 of this Attachment, <<customer\_short\_name>> may, at its option, relocate its equipment from an adjacent facility into the interior space subject to the rates, terms and conditions of this Attachment 4.
- 3.6 Other Physical Collocation Arrangements. BellSouth will provide other collocation arrangements that have been demonstrated to be technically feasible. A previously successful method of obtaining interconnection or access to unbundled network elements at a particular premises or point on any incumbent LEC's network is substantial evidence that such method is technically feasible in the case of substantially similar network premises or points. In seeking a particular collocation arrangement, either physical or virtual, <<customer\_short\_name>>, is entitled to a presumption that such arrangement is technically feasible if any LEC has deployed such collocation arrangement in any incumbent LEC premises.
- 3.7 Virtual Collocation. Virtual Collocation will be made available according to the terms and conditions described in BellSouth's FCC Tariff No. 1 for all states except Florida, which will be made available pursuant to the terms and conditions contained

- in the Florida Access Tariff. BellSouth shall provide Virtual Collocation at the rates set forth in Exhibit B of this Attachment. If there are any inconsistencies between BellSouth's FCC Tariff No. 1 or the Florida Access Tariff, and this Agreement, the rates, terms, and conditions of this Agreement shall control.
- 3.7.1 Virtual Collocation would occur when <<customer\_short\_name>> provides and leases to BellSouth its transmission and other collocation equipment dedicated to <<customer\_short\_name>>'s use. <<customer\_short\_name>> will be responsible for monitoring and controlling <<customer\_short\_name>>'s circuits terminating at BellSouth's Premises. Once space preparation is complete, and upon <<customer\_short\_name>>'s request, <<customer\_short\_name>> shall contract with a BellSouth Certified Supplier to install all equipment and facilities in accordance with BellSouth's guidelines and Specifications. <<customer\_short\_name>> shall be responsible for all costs of the BellSouth Certified Supplier's installation of <<customer\_short\_name>>'s virtual collocation arrangement. <<customer\_short\_name>> shall be responsible for all engineering associated with the installation and the provision of the equipment, necessary supplies and related documentation related to provisioning <<customer\_short\_name>>'s virtual collocation space. BellSouth will maintain and repair such equipment under the same intervals and with the same or better failure rates for performance of similar functions for comparable BellSouth equipment. Maintenance may include the change out of electronic cards provided by <<customer\_short\_name>>.
- 3.7.2 <<customer\_short\_name>> may purchase the equipment from a third party, and is not required to purchase the equipment from BellSouth.
- 3.7.3 BellSouth will make available digital, analog and fiber cross connects for Virtual Collocation at the rates contained in Exhibit B of this Attachment.
- 3.8 Remote Site Collocation.** Remote Site Collocation is the placement of <<customer\_short\_name>> owned facilities and equipment in BellSouth remote sites. Equipment ownership, maintenance and insurance are the responsibility of the <<customer\_short\_name>> or their approved agent. The minimum amount of a Remote Site Collocation arrangement is one bay/rack.
- 3.8.1 For equipment requiring special technical considerations, <<customer\_short\_name>> must provide the equipment layout, including spatial dimensions for such equipment pursuant to the generic requirements contained in Telcordia GR-63-Core, and shall be responsible for compliance with all special technical requirements associated with such equipment pursuant to Sections 3.8.2 and 3.8.3 following.
- 3.8.2 <<customer\_short\_name>> may elect to connect to a feeder line by submitting a service inquiry for that UNE to the Complex Resale Support Group, as follows:
- 3.8.2.1 connection to a BellSouth feeder line (when technically feasible) is achieved via cross connects located near the BellSouth equipment inside the Remote Site Location. In

- this case, the point of demarcation is the DSX, feeder distribution interface, or LGX panel in the Remote Site Location.
- 3.8.2.2 connection of the <<customer\_short\_name>> owned or leased entrance facilities into the Remote Site Collocation Space from <<customer\_short\_name>>'s own point of presence is permitted. However, BellSouth will designate the point of entrance at the Remote Site location housing the collocation space, so that it is physically accessible to both Parties.
- 3.8.3 Distribution lines will be accessed through <<customer\_short\_name>>'s provision of a copper cable through a conduit from the Remote Site collocation space to the feeder distribution interface of sufficient length for splicing. BellSouth will splice this cable to the distribution cable at the feeder distribution interface in 8-pair increments.
- 3.8.4 Virtual Collocation in the Remote Site. Virtual Collocation provides for the placement of <<customer\_short\_name>> owned equipment and facilities in a BellSouth Remote Site. The minimum amount of space offered for a virtual collocation arrangement is one rack/bay. BellSouth will lease <<customer\_short\_name>>'s entrance fiber or cable (to include copper) cabling and equipment for the nominal fee of one dollar. <<customer\_short\_name>>'s certified supplier will install the equipment in the rack/bay. BellSouth will then be responsible for performing all installation, maintenance and repair of the Virtual in the Remote Site plug-ins, when <<customer\_short\_name>> requests such work via a Service Order or Maintenance ticket.
- 3.9 [Parties Disagree]
- [<<customer\_short\_name>> Version] Cross Connect. **A cross-connection (cross-connect) is a cabling scheme between cabling runs subsystems, and equipment using patch cords or jumper wires that attach to connection hardware on each end, as defined and described by the FCC in its applicable rules and orders.** A cross connect **may consist of** a jumper on a frame (Main Distribution or Intermediate Distribution) or panel (DSX or LGX) that is used to connect equipment and/or facility terminations together. For collocation arrangements, the definition of cross connect will also include the tie cable connecting the frame/panel with the collocation demarc if the demarc is located at a point other than the frame/panel (POT Bay). A cross connect involved in connecting equipment/facility terminations with equipment/facility terminations associated with a collocation arrangement, either physical or virtual, is ordered separately and is charged at the rates found in Attachment 2 or Attachment 4. **A cross connect involved in the provision of services not associated with a collocation arrangement is not ordered but is a part of the provisioning of the service.**
- [BellSouth Version] Cross Connect. A cross connect is a jumper on a frame (Main Distribution or Intermediate Distribution) or panel (DSX or LGX) that is used to connect equipment and/or facility terminations together. For collocation arrangements, the definition of cross connect will also include the tie cable

connecting the frame/panel with the collocation demarc if the demarc is located at a point other than the frame/panel (POT Bay). A cross connect involved in connecting equipment/facility terminations with equipment/facility terminations associated with a collocation arrangement, either physical or virtual, is ordered separately and is charged at the rates found in Attachment 2 or Attachment 4.

- 3.10 Co-Carrier Cross Connect (CCXC). CCXCs are cross connects between <<customer\_short\_name>> and another collocated telecommunications carrier other than BellSouth in the same Premises. Where technically feasible, BellSouth will permit <<customer\_short\_name>> to interconnect directly between its virtual or physical collocation arrangements and those of another collocated telecommunications carrier within the same Premises via CCXCs and the associated cabling necessary to complete the interconnection consistent with FCC Rule 51.323. Both <<customer\_short\_name>>'s agreement and the other collocated telecommunications carrier's agreement must contain rates, terms and conditions for CCXCs. BellSouth applicable charges will be imposed on the requesting telecommunications carrier. <<customer-short\_name>> is prohibited from using the Collocation Space for the sole or primary purpose of cross connecting to other collocated telecommunications carriers.
- 3.10.1 <<customer\_short\_name>> may provision the CCXC using its own technicians, if certified as a BellSouth Certified Supplier, or contract with a BellSouth Certified Supplier to place the CCXC. The CCXC shall be provisioned through facilities owned or leased by <<customer\_short\_name>>. Such connections to other collocated telecommunications carriers may be made using either optical or electrical facilities (lit or dark). In cases where <<customer\_short\_name>>'s equipment and the equipment of the other collocated telecommunications carrier are located in contiguous caged Collocation Spaces, <<customer\_short\_name>> may use its own technicians to install CCXCs using either electrical or optical facilities (and associated patch cords, jumper cables, tie-pairs, etc.) between the equipment of both collocated telecommunication carriers and construct a dedicated cable support structure, if needed, between the two contiguous cages. <<customer\_short\_name>> shall deploy such optical or electrical connections directly between its own facilities and the facilities of another collocated telecommunications carrier without being routed through BellSouth's equipment. <<customer\_short\_name>> shall not provision CCXC on any BellSouth distribution frame, POT (Point of Termination) Bay, DSX (Digital System Cross Connect), or LGX (Light Guide Cross Connect). <customer\_short\_name>> is responsible for ensuring the integrity of the signal.
- 3.10.2 The CCXC fees provided for in this Agreement shall not apply when BellSouth has installed fiber or copper/coax cable support structure, pursuant to the terms and conditions of previous interconnection agreements between the Parties, that has been paid in full by <<customer\_short\_name>> via nonrecurring CCXC charges. If <<customer\_short\_name>> has ordered a service that originates from its collocation space and terminates to another collocater's space in the same BellSouth Premises, which caused a BellSouth technician to jumper the two collocation spaces together using <<customer\_short\_name>> specific connecting facility assignments (CFAs)

- provided by <<customer\_short\_name>> and the other collocator at a BellSouth frame, panel or existing POT bay (wherever the point of demarcation resides), then BellSouth will permit these cross connections to remain in-service as provisioned and at the rates at which they were provisioned (“grandfathered”).
- 3.10.3 <<customer\_short\_name>> shall be responsible for providing a letter of authorization (LOA), with the application, to BellSouth from the other collocated telecommunications carrier to which it will be cross-connecting <<customer\_short\_name>> provisioned CCXC shall utilize common cable support structure. There will be a recurring charge per linear foot, per cable, of common cable support structure used. In the case of two contiguous caged collocation arrangements, <<customer\_short\_name>> may use its own technicians to construct the dedicated support structure between the two collocation arrangements.
- 3.10.4 To request or self-provision CCXCs, <<customer\_short\_name>> must submit a Remote Site Application, an Initial Application or Subsequent Application to BellSouth. If no modification to the Collocation Space is requested other than the placement of CCXCs, the Co-Carrier Cross Connect/Direct Connect Only Application Fee for CCXCs, as set forth in Exhibit B, will apply. If modifications, in addition to the placement of CCXCs, are requested, the Initial Application or Subsequent Application Fee will apply as appropriate. BellSouth will bill this nonrecurring fee on the date that it provides an Application Response to <<customer\_short\_name>>. If the CCXC is requested as part of an Initial Application, only the Initial Application Fee shall apply, plus any other applicable charges.
- 3.10.5 If requested by <<customer\_short\_name>>, BellSouth will provision additional cable racking, if insufficient capacity is available to support <<customer\_short\_name>>’s request to provision a CCXC itself.
- 3.11 Direct Connect (DC). BellSouth will permit <<customer\_short\_name>> to interconnect directly between <<customer\_short\_name>>’s virtual and/or physical collocation arrangements within the same Premises by utilizing a DC. <<customer\_short\_name>> must use a BellSouth Certified Supplier to place the DC. The DC shall be provisioned through facilities owned by <<customer\_short\_name>>. In those cases where <<customer\_short\_name>>’s virtual and/or physical collocation space is contiguous in the central office, <<customer\_short\_name>> will have the option of using <<customer\_short\_name>>’s own technicians to deploy DC’s using either electrical or optical facilities between the collocation spaces and constructing its own dedicated cable support structure. <<customer\_short\_name>> will deploy such optical or electrical connections directly between its own facilities without being routed through BellSouth equipment. <<customer\_short\_name>> may not self-provision DC’s on any BellSouth distribution frame, POT, DSX (Digital System Cross-connect) or LGX (Light Guide Cross-connect).
- 3.11.1 <<customer\_short\_name>> is responsible for ensuring the integrity of the signal. <<customer\_short\_name>>-provisioned DC’s shall utilize common cable support

- structure. There will be a recurring charge per linear foot, and a nonrecurring charge per cable, of the actual common cable support structure used. In the case of two contiguous collocation arrangements, <<customer\_short\_name>> will have the option of using <<customer\_short\_name>>'s own technicians to construct its own dedicated support structure.
- 3.11.2 To request or self-provision DCs, <<customer\_short\_name>> must submit an Initial Application or Subsequent Application. If no modification to the Collocation Space is requested other than the placement of DC's, the Co-Carrier Cross Connect/Direct Connect Only Application Fee for DC, as defined in Exhibit B, will apply. If modifications in addition to the placement of DC's are requested, the Initial Application or Subsequent Application Fee will apply. This nonrecurring fee will be billed by BellSouth on the date that BellSouth provides an Application Response.
- 4. Occupancy**
- 4.1 Space Ready Date. BellSouth will notify <<customer\_short\_name>> in writing when the Collocation Space is ready for occupancy ("Space Ready Date).
- 4.2 Acceptance Walkthrough. <<customer\_short\_name>> will schedule and complete an acceptance walkthrough of the Collocation Space with BellSouth within fifteen (15) calendar days of the Space Ready Date. BellSouth will correct any deviations from <<customer\_short\_name>>'s original or jointly amended application requirements within seven (7) calendar days after the walkthrough, unless the Parties jointly agree upon a different time frame or mutually agree to accept the deviations. BellSouth will notify <<customer\_short\_name>> of a new Space Ready Date upon resolution of any deviations that require correction. Another acceptance walkthrough will then be scheduled and conducted within fifteen (15) calendar days of the new Space Ready Date. This follow-up acceptance walkthrough will be limited to only those items identified in the initial walkthrough. This process will continue until the Space Acceptance Date as defined below in Section 4.3 following.  
<<customer\_short\_name>> must notify BellSouth in writing that collocation equipment installation is complete and operational with BellSouth's network.
- 4.3 Space Acceptance Date. If <<customer\_short\_name>> completes its acceptance walkthrough within the fifteen (15) calendar day interval, the date of <<customer\_short\_name>>'s acceptance of the Collocation Space, as indicated by <<customer\_short\_name>>'s execution of a Space Acceptance Form, will be the Space Acceptance Date ("Space Acceptance Date").
- 4.3.1 In the event that <<customer\_short\_name>> fails to complete an acceptance walkthrough within this fifteen (15) calendar day interval, the Collocation Space shall be deemed accepted by <<customer\_short\_name>> on the Space Ready Date and the Space Acceptance Date will be established as the same date, provided that BellSouth has complied with all space preparation, provisions of <<customer\_short\_name>>'s BFFO, and that all required of BellSouth is complete.



- 4.3.2 If <<customer\_short\_name>> decides to occupy the space prior to the Space Ready Date, the date <<customer\_short\_name>> occupies the space will be deemed the Space Acceptance Date.
- 4.4 Termination of Occupancy. In addition to any other provisions addressing termination of occupancy in this Agreement <<customer\_short\_name>> may terminate occupancy in a particular Collocation Space by submitting a Subsequent Application, or a Remote Site Application requesting termination of occupancy. Such termination shall be effective upon BellSouth's execution of the Space Relinquishment Form for the collocation space(s) for which <<customer\_short\_name>> seeks to terminate occupancy, which termination date shall be the same date as <<customer\_short\_name>>'s date of the Space Relinquishment Form, provided <<customer\_short\_name>> has complied with all provisions of the Space Relinquishment Form. BellSouth may terminate <<customer\_short\_name>>'s right to occupy the Collocation Space in the event <<customer\_short\_name>> fails to comply with any material provision directly related to Collocation in this Agreement provided BellSouth gives <<customer\_short\_name>> thirty (30) calendar days' prior written notice of the failure to comply and gives <<customer\_short\_name>> an opportunity to cure during such period. Notwithstanding the above, any termination for non-payment of applicable fees, shall be in accordance with Attachment 7, Billing.
- 4.4.1 Upon termination of occupancy, <<customer\_short\_name>>, at its sole expense, shall remove its equipment and any other property from the Collocation Space. <<customer\_short\_name>> shall have thirty (30) calendar days (Removal Date) from the Subsequent Application BFFO Date to complete such removal, including the removal of all equipment and facilities of <<customer\_short\_name>>'s Guest(s), unless <<customer\_short\_name>>'s Guest(s) has assumed responsibility for the Collocation Space housing the Guest(s)'s equipment, pursuant to the Commissions' space exhaust requirements and executed the appropriate documentation required by BellSouth prior to the <<customer\_short\_name>> Removal Date.
- 4.4.2 Should <<customer\_short\_name>> or <<customer\_short\_name>>'s Guest(s) fail to vacate the Collocation Space by the Removal Date, BellSouth shall have the right to remove the equipment and dispose of the equipment and other property of <<customer\_short\_name>> or <<customer\_short\_name>>'s Guest(s), in any commercially reasonable manner that BellSouth deems fit, at <<customer\_short\_name>>'s expense and with no liability whatsoever for <<customer\_short\_name>>'s property or <<customer\_short\_name>>'s Guest(s)'s property, provided that BellSouth has not granted <<customer\_short\_name>>'s request for an extension of the Removal Date, and such request shall not unreasonably be denied.
- 4.4.3 Upon termination of <<customer\_short\_name>>'s right to occupy specific Collocation Space, the Collocation Space will revert back to BellSouth's space inventory, and <<customer\_short\_name>> shall surrender the Collocation Space to BellSouth in the same condition as when it was first occupied by

<<customer\_short\_name>>, with the exception of ordinary wear and tear, unless otherwise agreed to by the Parties. <<customer\_short\_name>>'s BellSouth Certified Supplier shall be responsible for updating and making any necessary changes to BellSouth's records as required by BellSouth's Specifications including, but not limited to, Central Office Record Drawings and ERMA Records. <<customer\_short\_name>> shall be responsible for the cost of removing any <<customer\_short\_name>> constructed enclosure, together with any supporting structures (e.g., racking, conduits or power cables), at the termination of occupancy and restoring grounds to their original condition

## **5. Use of Collocation Space**

- 5.1 Equipment Type. BellSouth shall permit the collocation and use of any equipment necessary for interconnection or access to unbundled network elements, in accordance with the applicable FCC and Commission rules and orders. Equipment is necessary for interconnection if an inability to deploy that equipment would, as practical, economic, or operational matter, preclude the requesting carrier from obtaining interconnection with BellSouth at a level equal in quality to that which BellSouth obtains within its own network or what BellSouth provides to any Affiliate, subsidiary, or other party.
- 5.2 Equipment is necessary for access to an unbundled network element if an inability to deploy that equipment would, as a practical, economic, or operational matter, preclude the requesting carrier from obtaining nondiscriminatory access to that unbundled network element, including any of its features, functions, or capabilities.
- 5.3 Multi-functional equipment shall be deemed necessary for interconnection or access to an unbundled network element if and only if the primary purpose and function of the equipment, as the requesting carrier seeks to deploy it, meets either or both of the standards set forth above in Sections 5.1 and 5.2 above. For a piece of equipment to be utilized primarily to obtain equal in quality interconnection or nondiscriminatory access to one or more unbundled network elements, there also must be a logical nexus between the additional functions the equipment would perform and the telecommunication services <<customer\_short\_name>> seeks to provide to its customers by means of the interconnection or unbundled network element. The collocation of those functions of the equipment that, as stand-alone functions, do not meet either of the standards set forth above in Sections 5.1 and 5.2 above must not cause the equipment to significantly increase the burden on BellSouth's property. Such equipment necessary for interconnection or access to unbundled network elements shall include, but is not limited to transmission equipment, equipment to light dark fiber, optical terminating equipment and multiplexers, digital subscriber line access multiplexers, routers, asynchronous transfer mode multiplexers, multifunction equipment, remote switching modules, fiber distribution frames, splitters, concentrators, cross connect systems, switching equipment other than traditional circuit switches, and ancillary equipment that enables a requesting carrier to assure proper provisioning and functioning of other collocated equipment. Subject

to the provisions of this Section, <<customer\_short\_name>> may order BellSouth tariffed services that connect to such equipment in its Collocation Space.

- 5.3.1 Examples of equipment that would not be considered necessary include, but are not limited to: traditional circuit switching equipment, equipment used exclusively for call related databases, computer servers used exclusively for providing information services, operations support system (OSS) equipment used to support collocated telecommunications carrier network operations, equipment that generates customer orders, manages trouble tickets or inventory, or stores customer records in centralized databases, etc. BellSouth will determine upon receipt of an application if the requested equipment is necessary based on the criteria established by the FCC. Multifunctional equipment placed on Premises must not place any greater relative burden on BellSouth's property than comparable single function equipment. BellSouth may object to the collocation of equipment based on criteria and in accordance with procedures and limitations established by applicable FCC and Commission rules and orders. With the exception of the equipment set forth in this Section 5.3.1, BellSouth may not block collocation and use of equipment while a proceeding to determine whether BellSouth may block such placement is pending. If BellSouth prevails in such a proceeding, <<customer\_short\_name>> will remove such equipment from the collocation, within thirty (30) days of receipt of a written request to do so from BellSouth, or as otherwise set forth in the relevant Commission order.
- 5.4 Whenever BellSouth objects to collocation of equipment by <<customer\_short\_name>> for purposes within the scope of Section 251 (c) (6) of the Act, BellSouth shall prove to the state commission that the equipment is not necessary for interconnection or access to unbundled network elements under the standards set forth above in this Section. BellSouth may not object to the collocation of equipment on the grounds that the equipment does not comply with safety or engineering standards that are more stringent than the safety or engineering standards that BellSouth applies to its own equipment. BellSouth may not object to the collocation of equipment on the ground that the equipment fails to comply with Network Equipment and Building Specifications performance standards or any other performance standards. Collocated equipment must comply with the following Telcordia Network Equipment Building Systems (NEBS) General Equipment Requirements: Criteria Level 1 requirements as outlined in Telcordia Special Report SR-3580, Issue 1. If BellSouth denies collocation of <<customer-short\_name>>'s equipment, citing safety standards, BellSouth must provide to <<customer\_short\_name>> within five (5) business days of the denial a list of all equipment that BellSouth locates at the Premises in question, together with an affidavit attesting that all of the equipment meets or exceeds the safety standard that BellSouth contends the competitor's equipment fails to meet. This affidavit must set forth in detail: the exact safety requirement that <<customer\_short\_name>>'s equipment does not satisfy; BellSouth's basis for concluding that <<customer\_short\_name>>'s equipment does not meet this safety requirement; and BellSouth's basis for concluding why collocation of equipment not meeting this safety requirement would compromise network safety. BellSouth reserves the right to

- permit on a nondiscriminatory basis collocation of equipment that does not necessarily comport with the requirements of applicable FCC and Commission rules and orders.
- 5.5 All <<customer\_short\_name>> Remote Site equipment installation shall comply with BellSouth TR 73503-11h, "Grounding – Engineering Procedures". Metallic cable sheaths and metallic strength members of optical fiber cables as well as the metallic cable sheaths of all copper conductor cables shall be bonded to the designated grounding bus for the Remote Site Location. All copper conducted pairs, working and non-working, shall be equipped with a solid-state protector unit (over-voltage protection only), which has been listed by a nationally recognized testing laboratory and located within <<customer\_short\_name>>'s Remote Site Collocation Space.
- 5.6 Terminations. <<customer\_short\_name>> shall not request more DS0, DS1, DS3 and optical terminations for a collocation arrangement than the total port or termination capacity of the equipment (including, but not limited to, transmission equipment, multiplexers, DSLAMS, DLC's, signal regenerators, cross connect panels) physically installed in the arrangement. The total capacity of the equipment collocated in the arrangement will include equipment contained in the application in question as well as the transmission equipment already placed in an arrangement. If full network termination capacity of the equipment being installed is not requested in the application, additional network terminations for the installed equipment will require the submission of another application. In the event that <<customer\_short\_name>> submits an application for terminations that exceed the total capacity of the collocated equipment, <<customer\_short\_name>> will be informed of the discrepancy and will be required to submit a revision to the application. Billing for terminations begin when services are ordered to those terminations via an ASR or a LSR.
- 5.7 <<customer\_short\_name>> will provide a list of those entities with a security interest in collocation equipment in <<customer\_short\_name>>'s collocation sites to BellSouth. This list will be updated by <<customer\_short\_name>> once annually. This information shall be expressly covered by the confidentiality provisions contained in Section 12 of the General Terms and Conditions of this Agreement. In no event shall BellSouth use the list of entities for any purpose other than contacting equipment owners or lien holders subsequent to abandonment of such equipment by <<customer\_short\_name>>.
- 5.8 No Marketing. <<customer\_short\_name>> shall not use the Collocation Space for marketing purposes, nor shall it place any marketing materials outside the Collocation Space or on the grounds of the Premises.
- 5.9 Collocation Space/Equipment Identification. <<customer\_short\_name>> shall place a plaque on or affix other identification (e.g., stenciling) to <<customer\_short\_name>>'s equipment, in order for BellSouth to identify <<customer\_short\_name>>'s equipment, including a list of emergency contacts with telephone numbers. For caged collocation the identification may be placed on a

- plaque affixed outside of the caged enclosure. All equipment must be identified for cageless collocation.
- 5.10 Entrance Facilities. <<customer\_short\_name>> may elect to place <<customer\_short\_name>>-owned or <<customer\_short\_name>>-leased (from BellSouth or a third party provider) fiber entrance facilities into its Collocation Space. BellSouth will designate the point of interconnection as close as reasonably possible to the Premises building housing the Collocation Space, such as at an entrance manhole or a cable vault, which are physically accessible by both Parties. <<customer\_short\_name>> will provide and place fiber cable at the point of entrance (in the entrance manhole) of sufficient length to be pulled through conduit and into the splice location. <<customer\_short\_name>> will provide and place copper or fiber cable through conduit from the Remote Site Collocation Space to the feeder distribution interface to the splice location of sufficient length for splicing by BellSouth. In Central Offices, <<customer\_short\_name>> will provide and install a sufficient length of fire retardant riser cable, to which the entrance cable will be spliced by BellSouth. The fire retardant riser cable will extend from the splice location to <<customer\_short\_name>>'s equipment in the Collocation Space. In the event <<customer\_short\_name>> utilizes a non-metallic, riser-type entrance facility, a splice will not be required. <<customer\_short\_name>> must contact BellSouth for instructions prior to placing any entrance facility cable in the manhole. <<customer\_short\_name>> is responsible for maintenance of the entrance facilities.
- 5.10.1 Central Office - Microwave Entrance Facilities. At <<customer\_short\_name>>'s option, BellSouth will accommodate, where technically feasible, a microwave entrance facility, pursuant to separately negotiated terms and conditions.
- 5.10.2 Central Office -Copper and Coaxial Cable Entrance Facilities. BellSouth shall permit <<customer\_short\_name>> to use copper or coaxial cable entrance facilities, if approved by the Commission. Notwithstanding the foregoing, in the case of adjacent collocation, copper facilities may be used between the adjacent collocation arrangement and the central office demarcation point unless BellSouth determines that limited space is available for the placement of entrance facilities.
- 5.11 Dual Entrance Facilities. BellSouth will provide at least two (2) interconnection points at each Premise where at least two such interconnection points are available and capacity exists. Upon receipt of a request by <<customer\_short\_name>> for dual entrance facilities to its physical Collocation Space, BellSouth shall provide <<customer\_short\_name>> with information regarding BellSouth's capacity to accommodate the requested dual entrance facilities. If conduit in the serving manhole(s) is available and is not reserved for another purpose or for utilization within twelve (12) months of the receipt of an application for collocation, BellSouth will make the requested conduit space available for installing a second entrance facility to <<customer\_short\_name>>'s arrangement. The location of the serving manhole(s) will be as close as reasonably possible to the Premises housing the Collocation Space, but determined by BellSouth on a reasonable and nondiscriminatory basis. Where dual entrance facilities are not available due to lack

- of capacity, BellSouth will provide this information to <<customer\_short\_name>> in the Application Response. BellSouth shall not deny an Application for the sole reason that dual entrance facilities are not available.
- 5.12 Shared Use. <<customer\_short\_name>> may utilize spare capacity on an existing interconnector's entrance facility for the purpose of providing an entrance facility to <<customer\_short\_name>>'s collocation arrangement within the same Premises.
- 5.12.1 In a Central Office, BellSouth shall allow the splice, as long as the fiber is non-working dark fiber. <<customer\_short\_name>> must arrange with BellSouth in accordance with all reasonable and nondiscriminatory requirements set forth in BellSouth's Special Construction Procedures, RL93-11-030BT, and provide a LOA from the other telecommunications carrier for BellSouth to perform the splice of the <<customer\_short\_name>> provided riser cable to the spare capacity on the entrance facility. If <<customer\_short\_name>> desires to allow another telecommunications carrier to use its entrance facilities, that telecommunications carrier must arrange with BellSouth in accordance with all reasonable and nondiscriminatory requirements set forth in BellSouth's Special Construction Procedures, RL93-11-030BT, and provide a LOA from <<customer\_short\_name>> for BellSouth to perform the splice of that telecommunications carrier's provided riser cable to the spare capacity on <<customer\_short\_name>>'s entrance facility.
- 5.12.2 For a Remote Site, the Parties will negotiate the rates, terms and conditions based upon the technical feasibility and physical capacity at the time of a request from <<customer\_short\_name>>.
- 5.13 Central Office Demarcation Point. BellSouth, in a reasonable and nondiscriminatory manner and in accordance with any and all applicable FCC and Commission rules and orders, will designate the point(s) of demarcation between <<customer\_short\_name>>'s equipment and/or network and BellSouth's network. Each Party will be responsible for the installation, maintenance and operation of all equipment/facilities on its side of the demarcation point and may make any terminations that may be required on their side of the demarcation point and may self-provision cross connects within the Collocation Space that may be required to activate service requests. <<customer\_short\_name>> shall have access to the demarcation point and all equipment and facilities on its side of the demarcation point. <<customer\_short\_name>> shall not have access to BellSouth's side of the demarcation point. When troubles cannot be clearly isolated to BellSouth's facilities and equipment, BellSouth will agree to test cooperatively with <<customer\_short\_name>> to assist in trouble isolation to a specific Party's facilities and equipment as set forth in Section 2.3.13 of BellSouth's FCC Tariff No. 1. If <<customer\_short\_name>> performs testing of its facilities and submits a trouble ticket to BellSouth indicating a trouble exists on BellSouth's side of the demarcation, then BellSouth will perform the required testing on its side of the demarcation point to isolate the trouble reported by <<customer\_short\_name>>. If BellSouth does find that a trouble exists on its side of the demarcation point after it has performed the required testing of its facilities, then BellSouth will take the necessary action to repair its

- facilities to eliminate the trouble and <<customer\_short\_name>> will not be charged for submission of the trouble ticket. If BellSouth cannot locate any trouble on its side of the demarcation point, then BellSouth will assess <<customer\_short\_name>> the applicable Maintenance of Services charge as set forth in Section 13.3.1 of BellSouth's FCC Tariff No. 1, based on the amount of time, in half-hour increments, it takes a BellSouth technician to complete the appropriate testing. If, within thirty (30) calendar days of BellSouth's billing of the Maintenance of Services charge, <<customer\_short\_name>> performs its testing of the same facilities and finds that the trouble has not been eliminated and does not reside on <<customer\_short\_name>>'s side of the demarcation point, then the <<customer\_short\_name>> shall submit a second trouble ticket to BellSouth. If, after testing has been performed by BellSouth, the trouble is actually determined to be on BellSouth's side of the demarcation point, BellSouth will not charge <<customer\_short\_name>> for the submission of the trouble ticket. BellSouth shall also credit <<customer\_short\_name>>'s account for the amount of the original Maintenance of Service charge on this same facility, within the next billing cycle. For 2-wire and 4-wire connections to BellSouth's network, the demarcation point shall be a common block on the BellSouth designated conventional distributing frame (CDF). <<customer\_short\_name>> shall be responsible for providing, and <<customer\_short\_name>>'s BellSouth Certified Supplier shall be responsible for installing and properly labeling/stenciling, the common, and necessary cabling pursuant to Section 7 below. For DS1 and DS3 connections, the demarcation point shall be a BellSouth provided DSX panel, or elsewhere if mutually agreed. For fiber connections, the demarcation point shall be a BellSouth provided LGX panel, or elsewhere if mutually agreed. For DS0 connections, the demarcation point shall be a BellSouth designated distributing frame. BellSouth shall not require <<customer\_short\_name>> to use an intermediate interconnection arrangement in lieu of a direct connection to BellSouth's network if technically feasible.
- 5.13.1 Existing point(s) of demarcation – <<customer\_short\_name>> provided POT Bay. BellSouth will grandfather existing point(s) of demarcation established at a <<customer\_short\_name>> provided POT Bay. <<customer\_short\_name>> shall order services using the existing remaining terminations in the POT bay.
- 5.13.2 Existing point(s) of demarcation – BellSouth provided POT Bay. BellSouth will grandfather existing point(s) of demarcation established at a BellSouth provided POT Bay. <<customer\_short\_name>> shall order services using the existing remaining cabling and terminations in the POT Bay.
- 5.13.3 Irrespective of where the demarcation point in a central office is located, BellSouth shall provide <<customer\_short\_name>> with access to the <<customer\_short\_name>>'s side of the demarcation point pursuant to this Section.
- 5.14 Remote Site Point of Demarcation. The point of demarcation will be as follows for each service level: DS-0 services will be the feeder distribution interface. DS-1 services will be at the designated BellSouth DS-1 cross connect panel. DS-3 services

- will be at the designated BellSouth DS-3 cross connect panel. Dark fiber services will be at the designated BellSouth LGX panel.
- 5.15 <<customer\_short\_name>>'s Equipment and Facilities. <<customer\_short\_name>>, or if required by this Attachment, <<customer\_short\_name>>'s BellSouth Certified Supplier, is solely responsible for the design, engineering, installation, testing, provisioning, performance, monitoring, maintenance and repair of the equipment and facilities used by <<customer\_short\_name>> and collocated in the Collocation Space or elsewhere in the Premises. Such equipment and facilities may include, but are not limited to, cable(s), equipment, and point of termination connections. <<customer\_short\_name>> need not use a BellSouth Certified Supplier to monitor, maintain or repair its own equipment and facilities.
- 5.16 BellSouth's Access to Enclosed Collocation Space. Except in the case of an emergency, BellSouth will not access <<customer\_short\_name>>'s locked enclosure prior to notifying <<customer\_short\_name>> at least seventy-two (72) hours or three (3) business days, whichever is greater, before access to the Collocation Space is required. BellSouth retains the right to access <<customer\_short\_name>>'s space for the purpose of making BellSouth equipment or cabling and building modifications (e.g., altering or removing racking, ducts, electrical wiring, HVAC, and cabling). <<customer\_short\_name>> may elect to be present whenever BellSouth performs work in the Collocation Space. The Parties agree that <<customer\_short\_name>> will not bear any of the expense associated with this type of work. BellSouth, its employees, vendors and agents, will comply at all times with its own security and safety procedures and requirements, while in <<customer\_short\_name>>'s space.
- 5.16.1 In cases of emergency, BellSouth will provide oral notice of entry as soon as possible (such oral notice most likely will be after entry) and, upon request, will provide subsequent written notice containing the time of entry, cause for emergency, and a listing of personnel allowed to enter the space during said emergency.
- 5.17 <<customer\_short\_name>> must provide the local BellSouth Central Office building contact with two Access Keys that will allow BellSouth entry into enclosed and locked Collocation Space, including but not limited to, Adjacent Arrangements, pursuant to this Section. Access Keys may not be duplicated under any circumstances. BellSouth agrees to be responsible for all Access Keys and for the return of all Access Keys after the contractual obligation with <<customer\_short\_name>> ends, upon the termination of this Attachment, or upon the termination of occupancy of an individual collocation arrangement.
- 5.18 Subject to the Limitation of Liability Section in the General Terms and Conditions of this Agreement, BellSouth shall be liable for the negligent actions of its employees or agents and for any damage caused to <<customer\_short\_name>>'s equipment, facilities or Collocation Space while in <<customer\_short\_name>>'s Collocation Space and shall indemnify and hold harmless <<customer\_short\_name>> from any claim, liability or damages that may result from such entry into



- <<customer\_short\_name>>'s Collocation Space by BellSouth, its agents, contractors or employees.
- 5.19 <<customer\_short\_name>>'s Access. <<customer\_short\_name>> shall have access to its Collocation Space or Remote Site Collocation Space twenty-four (24) hours a day, seven (7) days a week. Such access will be unescorted, provided <<customer\_short\_name>> complies with the requirements set forth in Section 13 of this Attachment. <<customer\_short\_name>> agrees to provide the name and social security number, date of birth, or driver's license number of each employee, supplier, or agent of <<customer\_short\_name>> or <<customer\_short\_name>>'s Guests that will be provided with access keys or cards (Access Keys) prior to the issuance of said Access Keys, using form RF-2906-C, the "CLEC and CLEC Certified Supplier Access Request and Acknowledgement" form. When distributing access keys or cards, BellSouth shall provide receipt acknowledgement forms, the "Collocation Acknowledgement Sheet" for access cards and the "Key Acknowledgement Form" for keys to <<customer\_short\_name>>. These receipt acknowledgement forms must be signed by <<customer\_short\_name>> and returned to BellSouth Access Management within fifteen (15) calendar days of <<customer\_short\_name>>'s receipt of keys or cards. Failure to return these properly acknowledged forms will result in the holding of subsequent access key or card requests until the proper acknowledgement documents have been received by BellSouth. Access Keys may not be duplicated under any circumstances. <<customer\_short\_name>> agrees to be responsible for all Access Keys and for the return of all Access Keys in the possession of <<customer\_short\_name>>'s employees, suppliers, Guests, or agents after termination of the employment relationship, the contractual obligation with <<customer\_short\_name>> ends, upon the termination of this Attachment, or upon the termination of occupancy of an individual collocation arrangement. The BellSouth Access Customer Advocacy Center (ACAC) emergency access contact numbers will be provided to <<customer\_short\_name>> for access related issues.
- 5.19.1 BellSouth will permit one accompanied site visit to <<customer\_short\_name>>'s designated collocation arrangement location, after receipt of the BFFO without charge to <<customer\_short\_name>>. <<customer\_short\_name>> must submit to BellSouth the completed Access Control Request Form for all employees or agents requiring access to the Premises within a minimum of thirty (30) calendar days prior to the date <<customer\_short\_name>> desires access to the Collocation Space or Remote Collocation Space. <<customer\_short\_name>> may submit a request for its one accompanied site visit to its designated collocation arrangement location at any time subsequent to BellSouth's receipt of the BFFO. BellSouth shall respond to such request within five (5) business days, and shall use best efforts to facilitate the visit on the date requested by <<customer\_short\_name>>. In the event <<customer\_short\_name>> desires access to the Collocation Space or Remote Collocation Space after submitting such a request, but prior to the approval of its access request, in addition to the first accompanied free visit, BellSouth shall permit <<customer\_short\_name>> to access the Collocation Space or Remote Collocation Space, prior to completing BellSouth's Training requirements (as set forth in Section 13 of this Attachment), accompanied by a security escort, at

- <<customer\_short\_name>>'s expense. <<customer\_short\_name>> must request escorted access to its designated collocation arrangement location at least three (3) business days prior to the date such access is desired. A security escort will be required whenever <<customer\_short\_name>> or its approved agent desires access to the entrance manhole.
- 5.19.2 Lost or Stolen Access Keys. The Parties shall immediately notify each other in writing in the case of lost or stolen Access Keys. If it becomes necessary for BellSouth to re-key buildings or enclosures or deactivate a card as a result of a lost Access Key(s) or for failure to return an Access Key(s), <<customer\_short\_name>> shall pay for the costs of re-keying or deactivating the card as set forth in the rates in Exhibit B of this Attachment. If it becomes necessary for <<customer-short\_name>> to rekey an enclosure due to BellSouth losing a key or if a key becomes stolen while in the possession of BellSouth, BellSouth will pay <<customer\_short\_name>> the applicable costs, as supported by documentation, to rekey an enclosure or replace lost or stolen keys that <<customer\_short\_name>> has previously provided to BellSouth.
- 5.20 Health Related Facilities and Parking. <<customer\_short\_name>> authorized personnel will have reasonable access to health related facilities (e.g., bathrooms, eyewash stations, shower stations, drinking water, etc. within the Premises), as well as to available parking.
- 5.21 Interference or Impairment. For purposes of this Section, the term “significantly degrades” shall be defined as an action that noticeably impairs a service from a user’s perspective.
- 5.21.1 [Parties Disagree]
- [<<customer\_short\_name>> Version] Notwithstanding any other provisions of this Attachment, <<customer\_short\_name>> shall not use any product or service provided under this Agreement, any other service related thereto or used in combination therewith, or place or use any equipment or facilities in any manner that 1) significantly degrades service provided by BellSouth; 2) endangers or damages the equipment or facilities of BellSouth **or any other telecommunications carrier collocated in the Premises;** 3) **knowingly and unlawfully** compromises the privacy of communications routed through the Premises; or 4) creates an unreasonable risk of injury or death to any individual or to the public. If BellSouth reasonably determines that any equipment or facilities of <<customer\_short\_name>> violates the provisions of this paragraph, BellSouth shall provide written notice to <<customer\_short\_name>>, which shall direct <<customer\_short\_name>> to cure the violation within forty-eight (48) hours of <<customer\_short\_name>>'s actual receipt of written notice or, if such cure is not feasible, at a minimum, to commence curative measures within twenty-four (24) hours and to exercise reasonable diligence to complete such measures as soon as possible thereafter. After receipt of the notice, the Parties agree to consult immediately and, if necessary, to conduct an inspection of the arrangement. The Parties will act in good faith and in a cooperative manner to determine or isolate the source of significant degradation. **Any dispute regarding**

**the source of the risk, impairment, interference, or degradation may be resolved pursuant to the dispute resolution provisions set forth in the General Terms and Conditions of this Agreement.**

**[BellSouth's Version]** Interference or Impairment. Notwithstanding any other provisions of this Attachment, <<customer\_short\_name>> shall not use any product or service provided under this Agreement, any other service related thereto or used in combination therewith, or place or use any equipment or facilities in any manner that 1) significantly degrades, **interferes with or impairs** service provided by BellSouth, **or by any other entity or any person's use of its telecommunications services**; 2) endangers or damages the equipment, **facilities or any other property of BellSouth or of any other entity or person**; 3) **compromises the privacy of any communications** routed through the Premises or 4) creates an unreasonable risk of injury or death to any individual or to the public. If BellSouth reasonably determines that any equipment or facilities of <<customer\_short\_name>> violates the provisions of this paragraph, BellSouth shall provide written notice to <<customer\_short\_name>>, which shall direct <<customer\_short\_name>> to cure the violation within forty-eight (48) hours of <<customer\_short\_name>>'s actual receipt of written notice or, if such cure is not feasible, at a minimum, to commence curative measures within twenty-four (24) hours and to exercise reasonable diligence to complete such measures as soon as possible thereafter. After receipt of the notice, the Parties agree to consult immediately and, if necessary, to conduct an inspection of the arrangement. The Parties will act in good faith and in a cooperative manner to determine or isolate the source of significant degradation. **Either Party may submit any dispute regarding the source of the risk, impairment, interference, or degradation to the Commission.**

5.21.2

**[Parties Disagree]**

**[<<customer\_short\_name>> Version]** Except in the case of the deployment of an advanced service which significantly degrades the performance of other advanced services or traditional voice band services, if the violation is of a character that poses an immediate and substantial threat of **physical** damage to property or injury or death to any person, then and only in that event, BellSouth may take such action as it deems necessary to eliminate such threat, including, without limitation, the interruption of electrical power to <<customer\_short\_name>>'s equipment which BellSouth has determined beyond a reasonable doubt is the cause of such threat. BellSouth must provide notice to <<customer\_short\_name>> prior to, or, if made impossible due to the nature of the threat imposed, as soon as possible after the taking of such action and provided that BellSouth, its agents, contractors or employees conduct themselves in strict compliance with this Section and except to the extent that such action by BellSouth fails to comport with the requirements of this paragraph or otherwise constitutes negligence, gross negligence or willful misconduct, BellSouth shall have no liability to <<customer\_short\_name>> for any damages arising from such action.

- [BellSouth Version]** Except in the case of the deployment of an advanced service which significantly degrades the performance of other advanced services or traditional voice band services, **if <<customer\_short\_name>> fails to commence curative action within twenty-four (24) hours and exercise reasonable diligence to complete such action as soon as possible or if the violation is of a character that poses an immediate and substantial threat of damage to property or injury or death to any person, or any other significant degradation, interference or impairment of BellSouth's or another entity's service,** then and only in that event, BellSouth may take such action as it deems necessary to eliminate such threat, including, without limitation, the interruption of electrical power to <<customer\_short\_name>>'s equipment which BellSouth has determined beyond a reasonable doubt is the cause of such threat. BellSouth will provide notice to <<customer\_short\_name>> prior to, or, if made impossible due to the nature of the threat imposed, as soon as possible after the taking of such action and provided that BellSouth, its agents, contractors or employees conduct themselves in strict compliance with this Section and except to the extent that such action by BellSouth fails to comport with the requirements of this paragraph or otherwise constitutes negligence, gross negligence or willful misconduct, BellSouth shall have no liability to <<customer\_short\_name>> for any damages arising from such action.
- 5.21.3 In the case of the deployment of an advanced service which significantly degrades the performance of other advanced services or traditional voice band services and <<customer\_short\_name>> fails to take curative action within forty-eight (48) hours, then BellSouth will establish before the Commission that the technology deployment is causing the significant degradation. Any claims of network harm presented to <<customer\_short\_name>> or, if subsequently necessary, the Commission must be supported by BellSouth with specific and verifiable information. When BellSouth demonstrates that a certain technology deployed by <<customer\_short\_name>> is significantly degrading the performance of other advanced services or traditional voice band services, <<customer\_short\_name>> shall discontinue deployment of that technology and migrate its customers to technologies that will not significantly degrade the performance of other such services. Where the only degraded service itself is a known disturber, and the newly deployed technology satisfies at least one of the criteria for a presumption that it is acceptable for deployment under applicable FCC and Commission rules and orders, the degraded service shall not prevail against the newly deployed technology.
- 5.22 Central Office Personalty and its Removal. Subject to requirements of this Attachment, <<customer\_short\_name>> may place or install in or on the Central Office Collocation Space such facilities and equipment, including storage for and spare equipment, as it deems desirable for the conduct of business, provided that such equipment is telecommunications equipment, or is desirable for the maintenance and operation of the collocated telecommunications equipment, and does not violate floor loading requirements, imposes or could impose or contains or could contain environmental conditions or hazards. Personal property, facilities and equipment placed by <<customer\_short\_name>> in the Collocation Space shall not become a part of the Collocation Space, even if nailed, screwed or otherwise fastened to the

- Collocation Space, but shall retain its status as personalty and may be removed by <<customer\_short\_name>> at any time. Any damage caused to the Collocation Space by <<customer\_short\_name>>'s employees, suppliers, agents or representatives during the removal of such property shall be promptly repaired by <<customer\_short\_name>>'s expense.
- 5.23 Alterations. Under no condition shall <<customer\_short\_name>> or any person acting on behalf of <<customer\_short\_name>> make any rearrangement, modification, augment, improvement, addition, and/or other alteration which could affect in any way space, power, HVAC, and/or safety considerations to the Collocation Space or the Premises, hereinafter referred to individually or collectively as "Alterations", without the express written consent of BellSouth, which shall not be unreasonably withheld. The cost of any such Alteration shall be paid by <<customer\_short\_name>>. Any such Alteration shall require a Subsequent Application and will result in the assessment of a Remote Site Application Fee, a Subsequent Application Fee, an Administrative Only Application Fee or an Initial Application Fee as set forth in Section 6.2.1 below, and, which will be billed by BellSouth on the date that BellSouth provides <<customer\_short\_name>> with an Application Response.
- 5.24 Janitorial Service. <<customer\_short\_name>> shall be responsible for the general upkeep of its Collocation Space. <<customer\_short\_name>> shall arrange directly with a BellSouth Certified Supplier for janitorial services applicable to Caged Collocation Space. BellSouth shall provide a list of such suppliers on a site-specific basis, upon request.
- 6. Ordering and Preparation of Central Office and Remote Site Collocation Space**
- 6.1 Initial Application. For <<customer\_short\_name>> or <<customer\_short\_name>>'s Guest(s) initial equipment placement, <<customer\_short\_name>> shall submit to BellSouth a Physical Expanded Interconnection Application Document (Initial Application). The Initial Application is considered Bona Fide when it is complete and accurate, meaning that all of the required fields on the application are completed with the appropriate type of information
- 6.1.1 Initial Application Fee. An Application Fee, as set forth in Exhibit B, will apply to each Initial Application submitted by <<customer\_short\_name>>, and will be billed by BellSouth on the date that BellSouth provides <<customer\_short\_name>> with an Application Response.
- 6.2 Subsequent Application. In the event <<customer\_short\_name>> or <<customer\_short\_name>>'s Guest(s) desires to modify the Collocation Space after a BFFO, <<customer\_short\_name>> shall complete an application that contains all of the detailed information associated with an Alteration to the Collocation Space, as defined in Section 5.23 of this Attachment ("Subsequent Application"). The Subsequent Application is considered Bona Fide when it is complete and accurate, meaning that all of the required fields on the Subsequent Application are completed

- with the appropriate type of information associated with the Alteration. BellSouth shall determine what modifications, if any, to the Premises are necessary to accommodate the change requested by <<customer\_short\_name>> in the application. Such modifications to the Premises may include, but are not limited to: floor loading changes, changes necessary to meet HVAC requirements, changes to power plant requirements, equipment additions, etc.
- 6.2.1 Subsequent Application Fee. The application fee paid by <<customer\_short\_name>> for its request for an Alteration shall be dependent upon the level of assessment needed for the Alteration requested. Where the Subsequent Application does not require assessment for provisioning or construction work but requires administrative costs by BellSouth, an Administrative Only Application Fee will be required as set forth in Exhibit B. This Administrative Only Application Fee will be applicable in instances such as Transfer of Ownership of the Collocation Space, Removal of Equipment from the Collocation Space, where the removal requires no physical work to be done by BellSouth, modification to an application prior to BFFO and V-to-P Conversion (In Place). The fee for a Subsequent Application where the Alteration requested has limited effect (e.g., requires limited assessment but no capital expenditure by BellSouth as sufficient cable support structure, HVAC, power and terminations are available) shall be the Subsequent Application Fee as set forth in Exhibit B. If the modification requires capital expenditure, an Initial Application Fee shall apply. This nonrecurring fee will be billed on the date that BellSouth provides <<customer\_short\_name>> with an Application Response.
- 6.3 Remote Site Application. When <<customer\_short\_name>> or <<customer\_short\_name>>'s Guest(s) desires to install a bay/rack in a Remote Site Location, <<customer-short\_name>> shall submit to BellSouth a Physical Expanded Interconnection Application Document (Remote Site Application). The Remote Site Application is Bona Fide when it is completed and accurate, meaning that all required fields on the Remote Site Application are completed with the appropriate type of information. An application fee, as set forth in Exhibit B, will apply which will be billed on the date that BellSouth provides an Application Response. The placement of an additional bay/rack at a later date will be treated in the same fashion and a Remote Site Application will be required. The installation of additional shelves/ equipment, subject to the restrictions contained in Section 3.8 above, within an existing bay or rack does not require a Remote Site Application.
- 6.3.1 Availability of Space. Upon submission of an application, BellSouth will permit <<customer\_short\_name>> to physically collocate in any available full bay/rack of space, pursuant to the terms of this Attachment, at any BellSouth Remote Site Location, unless BellSouth has determined that there is no full bay/rack of space available due to space limitations after BellSouth has conducted a review of all space within the Remote Site Location or that collocation at the Remote Site Location is not practical for technical reasons. In the event space is not immediately available at a Remote Site Location, BellSouth reserves the right to make additional space available, in which case the conditions in Section 7 below shall apply, or BellSouth may elect to deny space in accordance with this Section in which case virtual or

- adjacent collocation options may be available. If the amount of space requested is not available, BellSouth will notify <<customer\_short\_name>> of the amount that is available.
- 6.4 Space Preferences. If <<customer\_short\_name>> has previously requested and received a Space Availability Report for the Premises, <customer\_short\_name>> may submit up to three (3) space preferences on its application by identifying the specific space identification numbers referenced on the Space Availability Report for the space it is requesting. In the event BellSouth cannot accommodate the <<customer\_short\_name>>'s preference(s), <<customer\_short\_name>> may accept the space allocated by BellSouth or cancel its application, (without incurring an application fee), and submit another application requesting additional space preferences for the same central office. This application will be treated as a new application and an application fee will be billed by BellSouth on the date that BellSouth provides <<customer\_short\_name>> with an Application Response.
- 6.5 Space Availability Notification.
- 6.5.1 Unless otherwise specified, BellSouth will respond to an application within ten (10) calendar days as to whether space is available or not available within a requested Premises. BellSouth's electronic application system will indicate when the application is Bona Fide. If the application cannot be Bona Fide, BellSouth will describe the items necessary to cause the application to become Bona Fide. If the amount of space requested is not available, BellSouth will notify <<customer\_short\_name>> of the amount of space that is available and no application fee will apply. When BellSouth's response includes an amount of space less than that requested by <<customer\_short\_name>> or space that is configured differently, no application fee will apply. If <<customer\_short\_name>> decides to accept the available space, <<customer\_short\_name>> must resubmit its application to reflect the actual space available, including the configuration of the space. When <<customer\_short\_name>> resubmits its application, BellSouth will bill <<customer\_short\_name>> the appropriate application fee.
- 6.5.2 BellSouth will respond to a Florida and Tennessee application within fifteen (15) calendar days as to whether space is available or not available within a Premises. BellSouth's electronic application system will indicate when the application is Bona Fide. If the application cannot be Bona Fide, BellSouth will describe the items necessary to cause the application to become Bona Fide. If the amount of space requested is not available, BellSouth will notify <<customer\_short\_name>> of the amount of space that is available or space that may be configured differently and no application fee will apply. If <<customer\_short\_name>> decides to accept the available space, <<customer\_short\_name>> must amend its application to reflect the actual space available, including the configuration of the space, prior to submitting a BFFO.
- 6.5.3 Denial of Application. If BellSouth notifies <<customer\_short\_name>> that no space is available ("Denial of Application"), BellSouth will not assess an application fee to

- <<customer\_short\_name>>. After providing written notice to <<customer\_short\_name>> that BellSouth has no available space in the requested Premises, BellSouth will allow <<customer\_short\_name>>, upon request, to tour the entire Premises within ten (10) calendar days of such Denial of Application, or as otherwise agreed to by the Parties. In order to schedule this tour, the request for the tour of the Premises must be received by BellSouth at least five (5) calendar days prior to the tour date.
- 6.5.4 BellSouth's written notice of denial shall provide <<customer\_short\_name>> with information relevant to the denial of its request for collocation space, and give some detail as to why the space was denied.
- 6.5.5 Expedited Removal of Equipment in a Space Exhaust Scenario. BellSouth shall remove obsolete unused equipment from its Premises prior to denying a request for collocation on the grounds of space limitations, unless BellSouth proves to the Commission that collocation at the point is not technically feasible.
- 6.5.6 BellSouth will provide virtual collocation in accordance with applicable FCC and Commission rules and orders.
- 6.5.7 Filing of Petition for Waiver. Upon Denial of Application, BellSouth will timely file a petition with the Commission pursuant to 47 U.S.C. § 251(c)(6). BellSouth shall provide to the Commission any information required or requested by that Commission. Such information shall include which space, if any BellSouth or any of BellSouth's affiliates have reserved for future use and a detailed description of the specific future uses for which the space has been reserved. Subject to an appropriate nondisclosure agreement or provision, BellSouth shall permit <<customer\_short\_name>> to inspect any floor plans or diagrams that BellSouth provides to the Commission.
- 6.6 Waiting List. On a first-come, first-served basis, governed by the date of receipt of an application or Letter of Intent, BellSouth will maintain a waiting list of requesting carriers who have either received a Denial of Application or, where it is publicly known that the Premises is out of space, have submitted a Letter of Intent to collocate in that Premises. BellSouth will notify the requesting carriers on the waiting list by mail when space becomes available, according to the position of each requesting carrier on said waiting list.
- 6.6.1 In Florida, on a first come, first served basis, governed by the date of the receipt of an application or Letter of Intent, BellSouth will maintain a waiting list of requesting carriers who have either received a Denial of Application or, where it is publicly known that the Premises is out of space, have submitted a Letter of Intent to collocate in that Premises. Sixty (60) calendar days prior to space becoming available, if known, BellSouth will notify the Commission and the telecommunications carriers on the waiting list by mail when space becomes available according to the position of each telecommunications carrier on said waiting list. If BellSouth does not know sixty (60) calendar days in advance of when space will become available, BellSouth



- will notify the Commission and the telecommunications carriers on the waiting list within two (2) business days of the determination that space is available. A telecommunications carrier that, upon denial of physical collocation, requests virtual collocation shall be automatically placed on the waiting list.
- 6.7 When space becomes available, <<customer\_short\_name>> must submit an updated, complete, and correct application to BellSouth within thirty (30) calendar days of notification by BellSouth that space will be available in the Premises previously out of space. If <<customer\_short\_name>> has originally requested caged Collocation Space and cageless Collocation Space becomes available, <<customer\_short\_name>> may refuse such space and notify BellSouth in writing within the thirty (30) calendar day timeframe that <<customer\_short\_name>> wants to maintain its place on the waiting list, without accepting the available cageless Collocation Space. <<customer\_short\_name>> may accept an amount of space less than its originally requested space by submitting an application as set forth above, and upon request, may maintain its position on the waiting list for the remaining space that was initially requested. If <<customer\_short\_name>> does not submit an application or notify BellSouth in writing as described above, BellSouth will offer the space to the next telecommunications carrier on the waiting list and remove <<customer\_short\_name>> from the waiting list. Upon request, BellSouth will advise <<customer\_short\_name>> as to its position on the waiting list.
- 6.8 Public Notification. BellSouth will maintain on its Interconnection Services website a notification document that will indicate all Premises that are without available space. BellSouth shall update such document within ten (10) calendar days of the date that BellSouth becomes aware that insufficient space is available to accommodate physical collocation. BellSouth will also post a document on its Interconnection Services website that contains a general notice when space has become available in a Premises previously on the space exhaust list.
- 6.9 Application Response.
- 6.9.1 In Alabama, Georgia, Kentucky, Louisiana, Mississippi, North Carolina, and South Carolina, when space has been determined to be available for caged or cageless arrangements, BellSouth will provide an Application Response within twenty (20) calendar days of receipt of a Bona Fide application for physical collocation and ten (10) calendar days for virtual collocation. The Central Office Application Response will include sufficient information to enable <<customer\_short\_name>> to place a Firm Order, which, at a minimum, will consist of the configuration of the space, the Cable Installation Fee, Cable Records Fee, and any other applicable space preparation fees, as described in Section 8 below.
- 6.9.1.1 BellSouth will provide the Remote Site Application Response in Alabama, Georgia, Kentucky, Mississippi, North Carolina, and South Carolina, when space has been determined to be available, within twenty (20) calendar days of receipt of a Bona Fide application. The Application Response will include, at a minimum, the

configuration of the space, the Cable Installation Fee, Cable Records Fee, and the space preparation fees, as described in Section 8 below.

- 6.9.1.2 BellSouth will provide the Remote Site Application Response in Louisiana, when space has been determined to be available, within thirty (30) calendar days for one (1) to ten (10) applications; thirty-five (35) calendar days for eleven (11) to twenty (20) applications; and for requests of more than twenty (20) applications, the Application Response interval will be increased by five (5) calendar days for every five (5) applications received within five (5) business days. The Application Response will include, at a minimum, the configuration of the space, the Cable Installation Fee, Cable Records Fee, and the space preparation fees, as described in Section 8 below.
- 6.9.2 In Florida and Tennessee, within fifteen (15) calendar days of receipt of a Bona Fide application, when space has been determined to be available or when a lesser amount of space than that requested is available, then with respect to the space available, BellSouth will provide an Application Response including sufficient information to enable <<customer\_short\_name>> to place a Firm Order. The Central Office Application Response will include, at a minimum, the configuration of the space, the Cable Installation Fee, Cable Records Fee, and the space preparation fees, as described in Section 8 below. When <<customer\_short\_name>> submits ten (10) or more applications within ten (10) calendar days, the initial fifteen (15) calendar day response interval will increase by ten (10) calendar days for every additional ten (10) applications or fraction thereof.
- 6.9.2.1 BellSouth will provide the Remote Site Application Response in Florida, within fifteen (15) calendar days of receipt of a Bona Fide application, when space has been determined to be available or when a lesser amount of space than that requested is available, then with respect to the space available, BellSouth will provide an Application Response including sufficient information to enable <customer\_short\_name>> to place a Firm Order. The Application Response will include, at a minimum, the configuration of the space, the Cable Installation Fee, Cable Records Fee, and the space preparation fees, as described in Section 8 below. When <<customer\_short\_name>> submits ten (10) or more applications within ten (10) calendar days, the initial fifteen (15) calendar day response period will increase by ten (10) calendar days for every additional ten (10) applications or fraction thereof.
- 6.9.2.2 BellSouth will provide the Remote Site Application Response in Tennessee, when space has been determined to be available, within twenty (20) calendar days of receipt of a Bona Fide application. The Application Response will include, at a minimum, the configuration of the space, the Cable Installation Fee, Cable Records Fee, and the space preparation fees, as described in Section 8 below.
- 6.10 Application Modifications.
- 6.10.1 If a modification or revision is made to any information in the Bona Fide Application prior to a BFFO, with the exception of modifications to Customer Information,

Contact Information or Billing Contact Information, at the request of <<customer\_short\_name>>, or necessitated by technical considerations agreed to by both Parties, the application shall be considered a new application and handled as a new application with respect to the response and provisioning intervals. BellSouth will charge <<customer\_short\_name>> the appropriate application fee associated with the level of assessment performed by BellSouth. If the modification requires no labor or capital expenditure by BellSouth, but BellSouth must perform an assessment of the application to evaluate whether or not BellSouth would be required to perform necessary infrastructure or provisioning activities, then an Administrative Only Application Fee shall apply. The fee for an application modification where the modification requested has limited effect (e.g., requires labor expenditure but no capital expenditure by BellSouth and where sufficient cable support structure, HVAC, power and terminations are available) shall be the Subsequent Application Fee as set forth in Exhibit B. A modification involving a capital expenditure by BellSouth shall require <<customer\_short\_name>> to submit the application with an Initial Application Fee. This nonrecurring fee will be billed by BellSouth on the date that BellSouth provides <<customer\_short\_name>> with an Application Response.

#### 6.11 Bona Fide Firm Order.

6.11.1 <<customer\_short\_name>> shall indicate its intent to proceed with its request for collocation space in a BellSouth Premises by submitting a Bona Fide Firm Order to BellSouth. The BFFO must be received by BellSouth no later than thirty (30) calendar days after receipt of BellSouth's Application Response to <<customer\_short\_name>>'s Bona Fide Application or <<customer\_short\_name>>'s application will expire.

6.11.2 BellSouth will establish a firm order date based upon the date BellSouth is in receipt of <<customer\_short\_name>>'s BFFO. BellSouth will acknowledge the receipt of <<customer\_short\_name>>'s BFFO within seven (7) calendar days of receipt, so that <<customer\_short\_name>> will have positive confirmation that its BFFO has been received. BellSouth's response to a BFFO will include a Firm Order Confirmation, which contains the firm order date. No revisions can be made to a BFFO.

### 7. Construction and Provisioning

#### 7.1 Construction and Provisioning Intervals.

7.1.1 In Florida and Tennessee, BellSouth will complete construction for physical and Remote Site collocation arrangements as soon as possible within a maximum of ninety (90) calendar days from receipt of a BFFO or as agreed to by the Parties. For Alterations requested to the Collocation Space after initial space completion, BellSouth will complete construction for physical and remote site collocation arrangements as soon as possible within a maximum of forty-five (45) calendar days from receipt of a BFFO or as agreed to by the Parties if no additional space requested.

- If BellSouth does not believe that construction for physical and remote site collocation will be completed within the relevant timeframe and BellSouth and <<customer\_short\_name>> cannot agree upon a completion date, within forty-five (45) calendar days of receipt of the BFFO for an initial request, and within thirty (30) calendar days of receipt of the BFFO for an Alteration, BellSouth may seek an extension from the Commission. For virtual collocation arrangements in Florida and Tennessee, BellSouth will complete construction for initial and Alterations requested to the virtual Collocation Space after initial space completion as soon as possible within a maximum of sixty (60) calendar days.
- 7.1.2 In Alabama, Georgia, Kentucky, Louisiana, Mississippi, North Carolina, and South Carolina, BellSouth will complete construction for caged collocation arrangements under ordinary conditions as soon as possible within a maximum of ninety (90) calendar days from receipt of a BFFO or as agreed to by the Parties. BellSouth will complete construction for cageless and Remote Site collocation arrangements under ordinary conditions as soon as possible within a maximum of sixty (60) calendar days from receipt of a BFFO and ninety (90) calendar days from receipt of a BFFO for extraordinary conditions, or as agreed to by the Parties. BellSouth will complete construction for virtual collocation arrangements under ordinary conditions as soon as possible within a maximum of fifty (50) calendar days under ordinary conditions from receipt of a BFFO and seventy five (75) calendar days from receipt of a BFFO for extraordinary conditions, or as agreed to by the Parties. Ordinary conditions are defined as space available with only minor changes to support systems required such as, but not limited to, HVAC, cabling and the power plant. Extraordinary conditions shall include, but not be limited to, major BellSouth equipment rearrangements or additions; power plant additions or upgrades; major mechanical additions or upgrades; a major upgrade for ADA compliance; environmental hazard or hazardous materials abatement; and arrangements for which equipment shipping intervals are extraordinary in length. The Parties may mutually agree to renegotiate an alternative provisioning interval or BellSouth may seek a waiver from this interval from the Commission.
- 7.1.3 Records Only Change. When <<customer\_short\_name>> adds equipment within initial demand parameters that requires no additional space preparation work on the part of BellSouth, then no additional charges or additional intervals will be imposed by BellSouth.
- 7.1.4 Central Office Augments. In the states of Alabama, Georgia, Kentucky, Louisiana, Mississippi, North Carolina, and South Carolina, BellSouth will provide the reduced intervals outlined below to <<customer\_short\_name>>, when <<customer\_short\_name>> requests a Central Office augment that is identified in Sections 7.1.4.1, 7.1.4.2, 7.1.4.3, 7.1.4.4 and 7.1.4.5 (“Augment”) after the Space Ready Date for existing physical collocation space. The cost of any such Augment shall be paid by <<customer\_short\_name>>. Unless otherwise set forth in Section 7.1.4.10 below, any such Augment application will require a Subsequent Application.

- 7.1.4.1 Simple Augments will be completed within twenty (20) calendar days after receipt of the BFFO for an:
- Extension of Existing AC Circuit Capacity within Arrangement Where Sufficient Circuit Capacity is Available
  - Fuse Change and/or Increase or Decrease -48V DC Power from Existing ILEC BDFB
- 7.1.4.2 Minor Augments will be completed within forty-five (45) calendar days after receipt of the BFFO for:
- 168 DS1s Terminations at the ILEC Demarcation Frame (Databasing Only; Panels, Relay Racks and Overhead Racking Exist)
  - 96 DS3s Terminations at the ILEC Demarcation Frame (Databasing Only; Panels, Relay Racks and Overhead Racking Exist)
  - 99 Fiber Terminations at the ILEC Demarcation Frame (Databasing Only; Panels, Relay Racks and Overhead Racking Exist)
  - Maximum of 2000 Service Ready DS0 Terminations at the ILEC Demarcation Frame (Databasing Only; Panels, Relay Racks and Overhead Racking Exist)
- 7.1.4.3 Intermediate Augments will be completed within sixty (60) calendar days after receipt of the BFFO for:
- 168 DS1s (Databasing and Installation of Termination Panels, Relay Racks or Additional Structure as Required)
  - 96 DS3s (Databasing and Installation of Termination Panels, Relay Racks or Additional Structure as Required)
  - 99 Fiber Terminations (Databasing and Installation of Termination Panels, Relay Racks or Additional Structure as Required)
  - 2000 DS0s (Databasing and Installation of Termination Panels, Relay Racks or Additional Structure as Required)
  - Install Cable Racking or Other Support Structures as Required to Support Co-Carrier Cross Connects (Adequate Floor or Ceiling Structural Capacity Exists and Support/Protection Structure for Fiber Patch Cord is Excluded)
- 7.1.4.4 Major Augments –Physical Collocation will be completed within ninety (90) calendar days after BFFO and includes all requests for additional physical collocation space (caged or cageless).
- 7.1.4.5 Major Augments – Virtual Collocation will be completed within seventy-five (75) calendar days after BFFO and includes all requests for additional virtual collocation space
- 7.1.4.6 If <<customer\_short\_name>> submits an Augment application request that includes two Augment items from the same category in Sections 7.1.4.1, 7.1.4.2, and 7.1.4.3 above, the Augment interval associated with the next highest augment category will apply (e.g., if two items from the minor Augment category are requested on the same

request, then an interval of sixty (60) calendar days from the receipt of the BFFO would apply, which is the interval associated with the intermediate category).

- 7.1.4.7 If <<customer\_short\_name>> submits an Augment application request that includes three Augment items from the same category in Sections 7.1.4.1, 7.1.4.2, and 7.1.4.3 above, the major Augment interval of ninety (90) calendar days from the receipt of the BFFO would apply (e.g., if three items from the simple augment category are requested on the same request for a physical collocation arrangement, then an interval of ninety (90) calendar days from the receipt of the BFFO would apply, which is the major physical augment interval; likewise if three items from the simple Augment category are requested on the same request for a virtual collocation arrangement, then an interval of seventy-five (75) calendar days from the receipt of the BFFO would apply, which is the major virtual Augment interval).
- 7.1.4.8 If <<customer\_short\_name>> submits an Augment application request that includes one Augment item from two separate categories in Sections 7.1.4.1, 7.1.4.2 and 7.1.4.3 above, the Augment interval associated with the higher augment category will apply (e.g., if an item from the minor augment category and an item from the intermediate Augment category are requested on the same request, then an interval of sixty (60) calendar days from the receipt of the BFFO would apply, which is the interval associated with the intermediate Augment category).
- 7.1.4.9 All Augments not expressly included in the Simple, Minor, Intermediate or Major categories as outlined above will be placed into the appropriate category as negotiated by <<customer\_short\_name>> and BellSouth. If <<customer\_short\_name>> and BellSouth are unable to determine the appropriate category through negotiation, then the appropriate major augment category identified in Sections 7.1.4.4 and 7.1.4.5 above would apply based on whether the Augment request is for <<customer\_short\_name>>'s physical or virtual collocation arrangement.
- 7.1.4.10 Individual application fees associated with simple, minor and intermediate Augment applications are contained in Exhibit B. The appropriate application fee will be assessed to <<customer\_short\_name>> at the time BellSouth provides <<customer\_short\_name>> with the Application Response. If <<customer\_short\_name>> requests multiple items from different Augment categories BellSouth will bill <<customer\_short\_name>> the Augment Application Cost, as identified in Exhibit B of this Attachment, associated with the higher Augment category only. <<customer\_short\_name>> will be assessed a Subsequent Application Fee for all Major Augment applications (Major Augments are defined above in Sections 7.1.4.4 and 7.1.4.5 above). The Subsequent Application Fee is also reflected in Exhibit B of this Attachment.
- 7.2 Joint Planning. Unless otherwise agreed to by the Parties, a joint planning meeting or other method of joint planning between BellSouth and <<customer\_short\_name>> will commence within a maximum of twenty (20) calendar days from BellSouth's receipt of a BFFO. At such meeting, the Parties will agree to the preliminary design

- of the Collocation Space and the equipment configuration requirements as reflected in the Application and affirmed in the BFFO. <<customer\_short\_name>> Upon mutual agreement and within a mutually agreed upon time frame, the Parties will exchange any additional information requested (including, but not limited to cable type and cable termination specifications, naming convention and requirements, diagrams or drawings depicting the exact path of entrance facilities from the interconnection point to the Collocation Space, power cabling connectivity, feeder and fuse specifications and requirements, BellSouth contacts and escalation procedures, and identification of demarcation points) at the Joint Planning Meeting.
- 7.3 Permits. Each Party or its agent(s) will diligently pursue filing for the permits required for the scope of work to be performed by that Party or its agent(s) within ten (10) calendar days of the completion of the finalized construction design and specifications.
- 7.4 Acceptance Walkthrough. <<customer\_short\_name>> will schedule and complete an acceptance walkthrough of each Collocation Space with BellSouth within fifteen (15) calendar days of BellSouth's notification to <<customer\_short\_name>> that the Collocation Space is ready for occupancy. In the event <<customer\_short\_name>> fails to complete an acceptance walkthrough within this fifteen (15) day interval, the Collocation Space shall be deemed accepted by <<customer\_short\_name>> provided that BellSouth has complied with all space preparation, provisions of <<customer\_short\_name>>'s BFFO, and that all required of BellSouth is completed on the Space Ready Date. BellSouth will correct any deviations to <<customer\_short\_name>>'s original or jointly amended design and/or specification requirements within seven (7) calendar days after the walkthrough, unless the Parties jointly agree upon a different timeframe. At the end of the acceptance walkthrough or after any deviations are corrected, <<customer\_short\_name>> will execute a Space Acceptance Form indicating its acceptance of the Collocation Space.
- 7.5 Central Office Circuit Facility Assignments (CFAs). BellSouth will provide CFAs to <<customer\_short\_name>> as soon as possible and no later than thirty (30) calendar days after BellSouth's receipt of a Bona Fide Firm Order, except as set forth in Section 7.5.1 following. The ACTL will be provided to <<customer\_short\_name>> no later than with the issuance of the CFA.
- 7.5.1 To provide CFAs to <<customer\_short\_name>> prior to the Provisioning Interval for those Premises in which <<customer\_short\_name>> has a physical collocation arrangement with a POT bay provided by <<customer\_short\_name>> or a virtual collocation arrangement, <<customer\_short\_name>> must provide BellSouth with the following information:
- 7.5.1.1 for a physical collocation arrangement with a <<customer\_short\_name>>-provided POT bay - a complete layout of the POT panels (equipment inventory update (EIU) form) showing locations, speeds, etc.
- 7.5.1.2 for a virtual collocation arrangement - a complete layout of <<customer\_short\_name>>'s equipment (equipment inventory update (EIU) form),

- including the locations of the low speed ports and the specific frame terminations to which the equipment will be wired by <<customer\_short\_name>>'s BellSouth Certified Supplier.
- 7.5.1.3 <<customer\_short\_name>> may submit an EIU form at any time after the twentieth (20<sup>th</sup>) calendar day after the BFFO. CFAs will be provided within ten (10) calendar days of receipt of the EIU form.
- 7.5.2 BellSouth will bill <<customer\_short\_name>> a nonrecurring charge, as set forth in Exhibit B, each time <<customer\_short\_name>> requests a resend of its CFAs for any reason other than a BellSouth error in the CFAs initially provided to <<customer\_short\_name>>.
- 7.5.3 For a Remote Site CFAs are not used. Distribution lines will be accessed by <<customer\_short\_name>> provisioning a copper cable through a conduit from the Remote Site collocation space to the feeder distribution interface (FDI) of sufficient length for splicing. BellSouth personnel will splice <<customer\_short\_name>>'s cable to a group/bundle of the distribution cable at the FDI. Groups/Bundles will be provided in 8-pair increments. In order to establish the cable/pair range <<customer\_short\_name>> must submit a Remote Site Splitter Ordering Document (RSOD) which can be found in the Remote Site High Frequency Spectrum (RS HFS) CLEC Information Package located on BellSouth's web site at [http://interconnection.bellsouth.com/guides/unedocs/rs\\_hfs.pdf](http://interconnection.bellsouth.com/guides/unedocs/rs_hfs.pdf). Once the cable/pair range is established <<customer\_short\_name>> can then submit LSRs for individual line activations.
- 7.6 Use of BellSouth Certified Supplier. <<customer\_short\_name>> shall select a supplier which has been approved as a BellSouth Certified Supplier to perform all construction, engineering as specified in TR 73503, installation and removal work. <<customer\_short\_name>>, if a BellSouth Certified Supplier, or <<customer\_short\_name>>'s BellSouth Certified Supplier must follow and comply with all of the reasonable and nondiscriminatory requirements, outlined in BellSouth TR 73503, TR 73519, TR 73572, and TR 73564. In some cases, <<customer\_short\_name>> must use a separate BellSouth Certified Supplier for those work activities associated with transmission equipment, switching equipment and power equipment, unless the BellSouth Certified Supplier has met the requirements for all of the required work activities. BellSouth shall provide <<customer\_short\_name>> with a list of BellSouth Certified Suppliers, upon request. <<customer\_short\_name>>, if a BellSouth Certified Supplier, or its BellSouth Certified Supplier(s) shall be responsible for installing <<customer\_short\_name>>'s equipment and associated components, extending power cabling to the BellSouth power distribution frame, performing operational tests after installation is complete, and notifying BellSouth's equipment engineers and <<customer\_short\_name>> upon successful completion of installation and all associated work.. In cases where a BellSouth Certified Supplier is used, the BellSouth Certified Supplier shall bill <<customer\_short\_name>> directly for all work performed for <<customer\_short\_name>> pursuant to this Attachment. BellSouth shall have no



- liability for, nor responsibility to pay, such charges imposed by <<customer\_short\_name>>'s BellSouth Certified Supplier. BellSouth shall make available its supplier certification program to <<customer\_short\_name>> or any supplier proposed by <<customer\_short\_name>> and will not unreasonably withhold certification.
- 7.7 Alarm and Monitoring. BellSouth shall place environmental alarms in the Premises for the protection of BellSouth equipment and facilities. <<customer\_short\_name>> shall be responsible for placement, monitoring and removal of environmental and equipment alarms used to service <<customer\_short\_name>>'s Collocation Space. Upon request, BellSouth will provide <<customer\_short\_name>> with an applicable tariffed service(s) to facilitate remote monitoring of collocated equipment by <<customer\_short\_name>>. Both Parties shall use best efforts to notify the other of any verified environmental condition (e.g., temperature extremes or excess humidity) known to that Party.
- 7.8 Virtual to Physical Collocation Relocation. <<customer\_short\_name>> may relocate its existing virtual collocation arrangement(s), according to the standard intervals identified in Sections 7.1.1 and 7.1.2 above, to a physical collocation arrangement(s) and pay the appropriate fees associated with physical collocation and the rearrangement or reconfiguration of services terminated in the virtual collocation arrangement, as set forth in Exhibit B to this Attachment 4. In the event BellSouth knows when additional space for physical collocation may become available at the location requested by <<customer\_short\_name>>, such information will be provided to <<customer\_short\_name>> in BellSouth's written denial of physical collocation space. To the extent that (i) physical Collocation Space becomes available to <<customer\_short\_name>> within one hundred eighty (180) calendar days of BellSouth's written denial of <<customer\_short\_name>>'s request for physical collocation, (ii) BellSouth had knowledge that the space was going to become available, and (iii) <<customer\_short\_name>> was not informed in the written denial that physical Collocation Space would become available within such one hundred eighty (180) calendar days, then <<customer\_short\_name>> may relocate its virtual collocation arrangement to a physical collocation arrangement and will receive a credit for any nonrecurring charges previously paid for such virtual collocation. <<customer\_short\_name>> must arrange with a BellSouth Certified Supplier for the relocation of equipment from its virtual Collocation Space to its physical Collocation Space and will bear the cost of such relocation.
- 7.9 Virtual to Physical Conversion (In-Place). Virtual collocation arrangements may be converted to "in-place" physical arrangements if the potential conversion meets the following four criteria: 1) there is no change in the amount of equipment or the configuration of the equipment that was in the virtual collocation arrangement; 2) the conversion of the virtual collocation arrangement will not cause the equipment or the results of that conversion to be located in a space that BellSouth has reserved for its own future needs; 3) the converted arrangement does not limit BellSouth's ability to secure its own equipment and facilities due to the location of the virtual collocation arrangement; and 4) any changes to the arrangement can be accommodated by

- existing power, HVAC, and other requirements. BellSouth will complete virtual to in-place physical collocation conversions within forty-five (45) calendar days from receipt of the BFFO. BellSouth will bill <<customer\_short\_name>> an Administrative Only Application Fee as set forth in Exhibit B on the date that BellSouth provides an Application Response to <<customer\_short\_name>>.
- 7.10 Cancellation. If at any time prior to space acceptance, <<customer\_short\_name>> cancels its order for Collocation Space(s) (Cancellation), BellSouth will bill the applicable nonrecurring rate(s) as set forth in Exhibit B for any and all work processes for which work has begun or been completed.
- 7.11 Licenses. <<customer\_short\_name>>, at its own expense, will be solely responsible for obtaining from governmental authorities, and any other appropriate agency, entity, or person, all rights, privileges, and licenses necessary or required, if any, to operate as a provider of telecommunications services to the public or to build-out, equip and/or occupy the Collocation Space.
- 7.12 Environmental Compliance. The Parties agree to utilize and adhere to the Environmental Hazard Guidelines identified in Exhibit A attached hereto.

## 8. Rates and Charges

8.1 [Parties Disagree]

[<<customer\_short\_name>> Version] Commission Approved Rates and Charges. <<customer\_short\_name>> agrees to pay the rates and charges identified in Exhibit B attached hereto. Where rates have been “grandfathered”, those rates shall be the rates that were in effect prior to the Effective Date of this Agreement, **unless application of such rates would be inconsistent with the underlying purpose for grandfathering**, or otherwise specified herein, and such rates shall be incorporated in Exhibit B attached hereto.

[BellSouth Version] Commission Approved Rates and Charges. <<customer\_short\_name>> agrees to pay the rates and charges identified in Exhibit B attached hereto. Where rates have been “grandfathered”, those rates shall be the rates that were in effect prior to the Effective Date of this Agreement, or otherwise specified herein, and such rates shall be incorporated in Exhibit B attached hereto.

8.2 Application Fee. BellSouth shall assess an application fee by generating a service order, which shall be issued at the time BellSouth responds that space is available pursuant to Section 6.9 above. BellSouth will bill this nonrecurring fee on the date that BellSouth provides an Application Response to <<customer\_short\_name>>.

8.2.1 In Tennessee, the applicable application fee for caged physical collocation is the planning fee for both Initial Applications and Subsequent Applications placed by <<customer\_short\_name>>. BellSouth will bill this nonrecurring fee on the date that BellSouth provides an Application Response to <<customer\_short\_name>>.

8.3 Rack/Bay Space. The rack/bay space charge includes reasonable charges for air conditioning, ventilation and other allocated expenses associated with maintenance of the Remote Site Location, and includes amperage necessary to power <<customer\_short\_name>>'s equipment. <<customer\_short\_name>> shall pay rack/bay space charges based upon the number of racks/bays requested. BellSouth will assign Remote Collocation Space in conventional remote site rack/bay lineups where technically feasible.

8.4 [Parties Disagree]

[<<customer\_short\_name>> Version] Billing for recurring charges for **floor space, if applicable**, will begin on the Space Acceptance Date as defined above in Section 4.3 above. In the event that <<customer\_short\_name>> fails to complete an acceptance walkthrough within the applicable fifteen (15th) calendar day interval, billing for recurring charges will commence on the Space Ready Date. If <<customer\_short\_name>> occupies the space prior to the Space Ready Date, the date <<customer\_short\_name>> occupies the space is deemed the new Space Acceptance Date and billing for recurring charges **for floor space, if applicable**, will begin on that date. **Billing for recurring charges for power (if drawn from BellSouth), will commence on the date upon which the primary and redundant connections from <<customer\_short\_name>>'s equipment in the Collocation Space to the BellSouth power board or BDFB are installed.** <<customer\_short\_name>> must notify BellSouth in writing when the collocation equipment to power source installation is complete.

[BellSouth Version] Recurring Charges. If <<customer\_short\_name>> has met the applicable fifteen (15th) calendar day walkthrough interval specified in Section 4.3 above, billing for recurring charges will begin upon the Space Acceptance Date. **In the event that <<customer\_short\_name>> fails to complete an acceptance walkthrough within the applicable fifteen (15th) calendar day interval, billing for recurring charges will commence on the Space Ready Date. If <<customer\_short\_name>> occupies the space prior to the Space Ready Date, the date <<customer\_short\_name>> occupies the space is deemed the new Space Acceptance Date and billing for recurring charges will begin on that date.**

8.5 <<customer\_short\_name>> shall continue the payment of all monthly fees to BellSouth until the date that <<customer\_short\_name>>, and if applicable <<customer\_short\_name>>'s Guest(s), has fully vacated the Collocation Space and the Space Relinquishment Form has been accepted by BellSouth. Billing for monthly recurring charges will cease on the date that <<customer\_short\_name>> and BellSouth conduct an inspection of the terminated space and jointly sign off on the Space Relinquishment Form or on the date that <<customer\_short\_name>> signs off on the Space Relinquishment Form and sends this form to BellSouth, if a subsequent inspection of the terminated space by BellSouth reveals no discrepancies. In the latter case, if subsequent inspection by BellSouth within fifteen (15th) calendar days of its receipt of the Space Relinquishment Form, does reveal discrepancies, billing for monthly recurring charges will cease on the date that BellSouth and

<<customer\_short\_name>> jointly conduct an inspection, which confirms that <<customer\_short\_name>> has corrected all of the noted discrepancies. A Subsequent Application Fee will not apply for the termination of occupancy.

8.6 [Parties Disagree]

[<<customer\_short\_name>> Version] Space Preparation. Space preparation fees consist of a nonrecurring charge for firm order processing and monthly recurring charges for central office modifications assessed per arrangement, per square foot and common systems modifications assessed per arrangement, per square foot for cageless collocation and per cage for caged collocation. <<customer\_short\_name>> shall remit payment of the nonrecurring firm order processing fee coincident with submission of a BFFO. The charges recover the costs associated with preparing the Collocation Space, which includes survey, engineering of the Collocation Space, design and modification costs for network, building and support systems. In the event <<customer\_short\_name>> opts for cageless space, the space preparation fees will be assessed based on the total floor space dedicated to <<customer\_short\_name>> as prescribed in this Section. The Space preparation fees provided for in this Attachment shall not apply when <<customer\_short\_name>> has paid space preparation charges through previously billed ICB or nonrecurring space preparation charges.

[BellSouth Version] Space Preparation. Space preparation fees consist of a nonrecurring charge for firm order processing and monthly recurring charges for central office modifications assessed per arrangement, per square foot and common systems modifications assessed per arrangement, per square foot for cageless collocation and per cage for caged collocation. <<customer\_short\_name>> shall remit payment of the nonrecurring firm order processing fee coincident with submission of a BFFO. The charges recover the costs associated with preparing the Collocation Space, which includes survey, engineering of the Collocation Space, design and modification costs for network, building and support systems. In the event <<customer\_short\_name>> opts for cageless space, the space preparation fees will be assessed based on the total floor space dedicated to <<customer\_short\_name>> as prescribed in this Section. The Space preparation fees provided for in this Attachment shall not apply when <<customer\_short\_name>> has paid **all** space preparation charges **in full** through previously billed ICB or nonrecurring space preparation charges.

8.7 Floor Space. Billing for floor space, if applicable, will begin on the Space Acceptance Date. The Floor Space Charge includes reasonable charges for lighting, HVAC, and other allocated expenses associated with maintenance of the Premises but does not include any expenses for power supplied to <<customer\_short\_name>> for its equipment. When the Collocation Space is enclosed, <<customer\_short\_name>> shall pay floor space charges based upon the number of square feet so enclosed. When the Collocation Space is not enclosed, <<customer\_short\_name>> shall pay floor space charges based upon the following floor space calculation: [(depth of the equipment lineup in which the rack is placed) + (0.5 x maintenance aisle depth) +

- (0.5 x wiring aisle depth)] X (width of rack and spacers). For purposes of this calculation, the depth of the equipment lineup shall consider the footprint of equipment racks plus any equipment overhang. BellSouth will assign unenclosed Collocation Space in conventional equipment rack lineups where feasible. In the event <<customer\_short\_name>>'s equipment requires special cable racking, isolated grounding or other treatment which prevents placement within conventional equipment rack lineups, <<customer\_short\_name>> shall be required to request an amount of floor space sufficient to accommodate the total equipment arrangement.
- 8.8 Cable Installation. Cable Installation Fee(s) are assessed per entrance cable placed. This nonrecurring fee will be billed by BellSouth upon receipt of <<customer\_short\_name>>'s BFFO.
- 8.9 Security Escort. Rates for a security escort are assessed according to the schedule appended hereto as Exhibit B beginning with the scheduled escort time. BellSouth will wait for one half (1/2) hour after the scheduled time for such an escort and <<customer\_short\_name>> shall pay for such half hour charges in the event <<customer\_short\_name>> fails to show up.
- 8.10 Cable Record charges. These charges apply for work required to build cable records in BellSouth systems. The VG/DS0 cable record charge is for a maximum of 3600 records. The Fiber cable record charge is for a maximum of ninety-nine (99) records. These nonrecurring fees will be billed upon receipt of <<customer\_short\_name>>'s BFFO.
- 8.11 [ Parties Disagree ]
- [<<customer\_short\_name>> Version] Power Rates. Rates for power are as set forth in Exhibit B of this Attachment. Applicable rates shall vary depending on whether <<customer\_short\_name>> elects to be billed on a "fused amp" basis, by electing to remain (or install new collocations or augments) under the traditional collocation power billing method, or on a "used amp" basis, by electing to convert collocations to (or install new collocations or augments under) the power usage metering option set forth in Section 9 below. Under either billing method, there will be rates applicable to grandfathered collocations for which power plant infrastructure costs have been prepaid under a ICB pricing or non-recurring charge arrangement and there will rates applicable where such grandfathering does not apply and power plant infrastructure is instead recovered via recurring charges.
- [BellSouth Version] Power Rates. Rates for power are as set forth in Exhibit B of this Attachment. **Recurring charges for -48V DC power will be assessed per amp per month based upon the BellSouth Certified Supplier engineered and installed power feed fused ampere capacity. In Tennessee**, applicable rates shall vary depending on whether <<customer\_short\_name>> elects to be billed on a "fused amp" basis, by electing to remain (or install new collocations or augments) under the traditional collocation power billing method or on a "used amp" basis, by electing to convert collocations to (or install new collocations or augments under) the power usage metering option set forth in Section 9 below. Under either billing method,

there will be rates applicable to grandfathered collocations for which power plant infrastructure costs have been prepaid under a ICB pricing or non-recurring charge arrangement and there will rates applicable where such grandfathering does not apply and power plant infrastructure is instead recovered via recurring charges.

8.11.1 [Parties Disagree]

[<<customer\_short\_name>> Version] Under the fused amp billing option, <<customer\_short\_name>> shall be billed at the Commission's most recently approved fused amp recurring rate for DC power. However, if the Parties either previously agreed to "grandfather" such arrangements or such arrangements are grandfathered as a result of <<customer\_short\_name>> having provided documentation to BellSouth demonstrating that <<customer\_short\_name>> paid installation costs under an ICB or nonrecurring rate schedule for the collocation arrangement power installation, <<customer\_short\_name>> will only be billed the recurring rate for the DC power in effect prior to the Effective Date of this Agreement, or, if such grandfathered rates had not been incorporated into the Parties' most recent Agreement, the **most recent Commission approved rate that does not include an infrastructure component shall apply.**

[BellSouth Version] **In Tennessee**, under the fused amp billing option, <<customer\_short\_name>> shall be billed at the Commission's most recently approved fused amp recurring rate for DC power. However, if the Parties either previously agreed to "grandfather" such arrangements or such arrangements are grandfathered as a result of <<customer\_short\_name>> having provided documentation to BellSouth demonstrating that <<customer\_short\_name>> paid installation costs under an ICB or nonrecurring rate schedule for the collocation arrangement power installation, <<customer\_short\_name>> will only be billed the recurring rate for the DC power in effect prior to the Effective Date of this Agreement, or, if such grandfathered rates had not been incorporated into the Parties' most recent Agreement, the **rates contained in Exhibit B of this Attachment.**

8.11.2 [Parties Disagree]

[<<customer\_short\_name>> Version] Under the power usage metering option, recurring charges for DC power are subdivided into a power infrastructure component and an AC usage component (based on DC amps consumed). However, if the Parties either previously agreed to "grandfather" such arrangements or such arrangements are grandfathered as a result of <<customer\_short\_name>> having provided documentation to BellSouth demonstrating that <<customer\_short\_name>> paid installation costs under an ICB or nonrecurring rate schedule for the collocation arrangement power installation, <<customer\_short\_name>> will only be billed a recurring rate for the AC usage based on the most recent Commission approved rate and the DC power infrastructure component exclusive of the costs previously paid through the ICB or NRC pricing (**as set by the Commission**).

[BellSouth Version] **In Tennessee**, Under the power usage metering option, recurring charges for DC power are subdivided into a power infrastructure component and an

AC usage component (based on DC amps consumed). However, if the Parties either previously agreed to “grandfather” such arrangements or such arrangements are grandfathered as a result of <<customer\_short\_name>> having provided documentation to BellSouth demonstrating that <<customer\_short\_name>> paid installation costs under an ICB or nonrecurring rate schedule for the collocation arrangement power installation, <<customer\_short\_name>> will only be billed a recurring rate for the AC usage based on the most recent Commission approved rate and the DC power infrastructure component exclusive of the costs previously paid through the ICB or NRC pricing.

8.11.3 Other. If no rate is identified in the contract, the rate for the specific service or function will be negotiated by the Parties upon request by either Party.

#### 8.12 Grandfathered Rates.

8.12.1 The rates for the recurring charges for grandfathered CCXC will be the rates in effect before the Effective Date of this Agreement, if any, and such rates shall be set forth in Exhibit B of this Attachment.

8.12.2 The grandfathered POT Bay rates are pursuant to state ordered rates for particular POT Bay elements.

8.12.3 Additional grandfathering provisions regarding collocation power charges are set forth in Section 8.11 of this Attachment.

8.12.4 Additional grandfathering provisions regarding space preparation charges are set forth in Section 8.6 of this Attachment.

### 9. **Central Office Power**

9.1 BellSouth shall make available –48 Volt (-48V) Direct Current (DC) power for <<customer\_short\_name>>’s Collocation Space at a BellSouth Battery Distribution Fuse Bay (BDFB). If <<customer\_short\_name>> was previously served off BellSouth’s main power board pursuant to <<customer\_short\_name>>’s previous Interconnection Agreement, that arrangement shall be grandfathered. Recurring charges for -48V DC power will be assessed as set forth in Section 8.11 above.

#### 9.1.1 [Parties Disagree]

[<<customer\_short\_name>> Version] Fused Amp Billing Option. Monthly recurring charges for -48V DC power will be assessed per fused amp per month in a manner consistent with Commission orders and as set forth in Section 8 of this Attachment. Nonrecurring charges for –48V DC power distribution, will be **as set by the Commission**.

[BellSouth Version] Fused Amp Billing. Monthly recurring charges for -48V DC power will be assessed per fused amp per month **based upon the engineered and installed power feed fused ampere capacity** in a manner consistent with



Commission orders and as set forth in Section 8 of this Attachment. Nonrecurring charges for –48V DC power distribution **will be based on the costs associated with collocation power plant investment and the associated infrastructure.**

9.1.2 [Parties Disagree]

[<<customer\_short\_name>> Version] Power Usage Metering Option. Monthly recurring charges for -48V DC power will be assessed based on a consumption component and, if applicable, an infrastructure component, as set forth in Section 8 of this Attachment. Nonrecurring charges for –48V DC power distribution will be **as set by the Commission.**

[BellSouth Version] Tennessee Power Usage Metering Option. **In Tennessee,** monthly recurring charges for -48V DC power will be assessed based on a consumption component and, if applicable, an infrastructure component, as set forth in Section 8 of this Attachment. Nonrecurring charges for –48V DC power distribution will be **based on the costs associated with collocation power plant investment and the associated infrastructure.**

9.1.3 [Parties Disagree]

[<<customer\_short\_name>> Version] When <<customer\_short\_name>> selects the power usage metering option for power billing, the following terms shall apply.

[BellSouth Version] **In Tennessee,** <<customer\_short\_name>> may select the power usage metering option for power billing, in which case the following terms shall apply.

- 9.1.3.1 BellSouth will arrange for all metering activities, which will include providing the necessary ammeter measurement device, to measure the actual power usage being drawn by <<customer\_short\_name>>'s collocation equipment on both the A and B power feeds. The AC usage component of the DC power charge will be based upon the sum of either the instantaneous or busy hour average electrical current readings, depending on the capabilities of the ammeter-measuring device. <<customer\_short\_name>> may, at its sole cost and expense, install its own meters on the BDFBs located in its collocation space, for the purposes of measuring actual power usage. <<customer\_short\_name>> will submit a Subsequent Application for each location that <<customer\_short\_name>> wants to convert to the metered power usage measurement option and agrees to include in the Comments Section of the Subsequent Application the following comments: "This Subsequent Application is <<customer\_short\_name>>'s certification that <<customer\_short\_name>> is opting to convert to the power usage measurement option and will permit BellSouth or a BellSouth Certified Supplier to use an ammeter-measuring device to measure its actual power usage or has installed a meter on its own BDFB, located in <<customer\_short\_name>>'s collocation space, to measure actual power usage on all power feeds." BellSouth will bill <<customer\_short\_name>> a Power Reconfiguration Application Fee, as set forth in Exhibit B of this Attachment, on the date that BellSouth provides an Application Response to the Subsequent Application.



- BellSouth shall then arrange, in coordination with <<customer\_short\_name>>, for the measurement of <<customer\_short\_name>>'s actual power usage on each power feed (all A and B feeds) once each quarter at each of <<customer\_short\_name>>'s collocation arrangements (i.e. quarterly metered reading service), for which <<customer\_short\_name>> has initially implemented the power usage metering option or submitted a Subsequent Application to convert arrangements to metered power usage. After the actual power usage measurements have been completed, these measurements will be used to calculate the AC Usage charge on <<customer\_short\_name>>'s bill for the following three (3) months or until the next measurement is taken. A minimum of ten (10) amps of -48V DC power usage, per A&B pair of power feeds (i.e., a 10 amps sum for both the A and B feeds combined), is required by BellSouth for <<customer\_short\_name>> to operate equipment in its collocation space. BellSouth shall bill <<customer\_short\_name>> for its monthly AC Usage for the following quarter based upon the sum of <<customer\_short\_name>>'s actual metered usage for each power feed (the A and B feeds), or at least ten (10) amps of -48V DC power for each A and B pair of power feeds at the applicable -48V DC amp AC Usage rate as set forth in Section 8 of this Attachment.
- 9.1.3.2 Either Party, within fifteen (15) calendar days of notice of the usage measurement established by the scheduled meter reading, may challenge the accuracy of that reading by requesting a new reading. If <<customer\_short\_name>> requests that an unscheduled (prior to the next scheduled quarterly power reading date) power usage reading be taken, then <<customer\_short\_name>> will be responsible for paying the "Additional Meter Reading Trip Charge" contained in Exhibit B of this Attachment. If BellSouth requests a power usage reading be taken in this instance, then <<customer\_short\_name>> will not be charged the "Additional Meter Reading Trip Charge" for the unscheduled meter reading. If the readings vary by more than ten (10) % or five (5) Amps, whichever is greater, the Parties shall work cooperatively to reconcile such discrepancies and establish the appropriate usage figure in a reasonable and expeditious manner. If the readings do not vary outside these ranges, the initial reading will be used to calculate <<customer\_short\_name>>'s AC Usage charge for the next three (3) months.
- 9.1.3.3 BellSouth shall assess <<customer\_short\_name>> a monthly recurring charge as set forth in Exhibit B of this Attachment for BellSouth's power plant infrastructure investment component of the DC power charges based upon <<customer\_short\_name>>'s requested fused amperage capacity, as reflected by <<customer\_short\_name>> on its Initial Application, as well as any Subsequent Applications (i.e., augment applications) and Power Reduction Forms, for the particular collocation arrangement being converted to the power usage metering option within the specified central office.
- 9.1.3.4 <<customer\_short\_name>> agrees to submit a Subsequent Application to BellSouth for notification when <<customer\_short\_name>> has removed or installed telecommunications equipment in <<customer\_short\_name>>'s collocated space. If there is no change in the size of the collocation space and no change in the requested

- fused amperage capacity, BellSouth will assess <<customer\_short\_name>> an Administrative Only Application fee for processing an application to remove or install telecommunications equipment. If there any changes in the size of the collocation space, the requested fused amperage capacity, or any other activities requested in the Subsequent Application, BellSouth will assess <<customer\_short\_name>> the Subsequent Application fee contained in Exhibit B of this Attachment. An associated change in power usage will be reflected in the billing cycle associated with the next regularly scheduled quarterly power measurement reading, unless either Party requests a reading of the power usage prior to this date. If <<customer\_short\_name>> requests that an unscheduled (prior to the next scheduled quarterly power reading date) power usage reading be taken when telecommunications equipment has been removed or installed or requested another reading for any other purpose in <<customer\_short\_name>>'s collocation space then <<customer\_short\_name>> will be responsible for paying the "Additional Meter Reading Trip Charge" contained in Exhibit B of this Attachment. If BellSouth requests a power usage reading be taken in this instance, then <<customer\_short\_name>> will not be charged the "Additional Meter Reading Trip Charge" for the unscheduled meter reading. Any changes in the existing power usage will become effective on the first (1<sup>st</sup>) day of the month following the date of the requested meter reading.
- 9.1.3.5 BellSouth will bill <<customer\_short\_name>> a monthly recurring charge per site in accordance with Exhibit B of this Attachment for <<customer\_short\_name>>'s collocation arrangements in Tennessee, which represents the costs for BellSouth and/or a BellSouth Certified Supplier to provide the clamp-on ammeter or other measurement device, perform the task of measuring the actual power usage at each requested collocation site, record the usage measurements and submit these measurements to the billing systems including any associated administrative expenses and applicable taxes.
- 9.1.3.6 BellSouth, at any time and at its own expense, shall have the right to verify the accuracy of <<customer\_short\_name>>'s BDFB meter(s) by performing its own meter reading(s) via an alternate method, such as, but not limited to, a clamp-on ammeter. If the meter readings vary significantly, the Parties agree to perform a joint investigation. If <<customer\_short\_name>>'s BDFB meter(s) is (are) found to be in error, then <<customer\_short\_name>> agrees to recalibrate, repair, or replace its meter as required. The Parties recognize that the meter readings discussed in this Attachment are generally instantaneous readings that can experience minor fluctuations due to usage traffic, voltage fluctuations, and the calibration of the meters themselves. The readings must vary by more than ten (10) % or five (5) Amps, whichever is greater, before any recalibration, repair, or replacement will be required. If the BellSouth reading is substantiated, then BellSouth has the right to adjust <<customer\_short\_name>>'s billing to reflect BellSouth's reading retroactive to the beginning of the quarter for which the last meter reading was taken.
- 9.1.3.7 If required, BellSouth and/or a BellSouth Certified Supplier hired by BellSouth to perform the meter reading activity, must be given access to

<<customer\_short\_name>>'s collocation space if the arrangement is a physical caged collocation arrangement. BellSouth and/or a BellSouth Certified Supplier shall provide <<customer\_short\_name>> with sufficient notification that access is required, defined herein as a minimum of forty-eight (48) hours. Once the date and time of access has been agreed upon, <<customer\_short\_name>> and BellSouth and/or a BellSouth Certified Supplier shall adhere to the agreed upon date and time, or provide sufficient notification, defined herein as a minimum of three (3) hours, to the other party if the original appointment will be missed or must be canceled and rescheduled. If <<customer\_short\_name>> fails to provide access to its caged collocation space or fails to provide BellSouth and/or a BellSouth Certified Supplier with sufficient notification of the necessity to cancel and/or reschedule the initial agreed-upon appointment, then <<customer\_short\_name>> will be assessed for each additional meter reading trip, as set forth in Exhibit B of this Attachment, that must be rescheduled due to <<customer\_short\_name>>'s failure to provide sufficient notice as described above. BellSouth will bill <<customer\_short\_name>> an "Additional Meter Reading Trip Charge" that BellSouth incurs, either from its own work forces or from a BellSouth Certified Supplier. <<customer\_short\_name>> and BellSouth and/or a BellSouth Certified Supplier may jointly agree to less stringent notification requirements, as convenience and practical business needs dictate, on a central office-by-central office basis. Both Parties agree that "practical business needs" may include any service interruption or restoration of service situation.

- 9.2 When obtaining power from the BDFB, fuses and power cables (A&B) must be engineered (sized) and installed by <<customer\_short\_name>>'s BellSouth Certified Supplier. <<customer\_short\_name>> is responsible for contracting with a BellSouth Certified Supplier for power distribution feeder cable runs from a BellSouth BDFB to <<customer\_short\_name>>'s equipment. The BellSouth Certified Supplier contracted by <<customer\_short\_name>> must provide BellSouth with a copy of the engineering power specifications prior to the day on which <<customer\_short\_name>>'s equipment becomes operational. BellSouth will provide the common power feeder cable support structure between the BellSouth BDFB and <<customer\_short\_name>>'s Collocation Space. <<customer\_short\_name>> shall contract with a BellSouth Certified Supplier who will be responsible for the following: dedicated power cable support structure within <<customer\_short\_name>>'s Collocation Space, power cable feeds, and terminations of cable.

- 9.3 [Parties Disagree]

[<<customer\_short\_name>> Version] If <<customer\_short\_name>> elects to install its own DC Power Plant, BellSouth shall provide Alternating Current (AC) power to feed <<customer\_short\_name>>'s DC Power Plant. Charges for AC power will be assessed **in the same manner as charges for DC power are assessed, as set forth in Section 9.1 (including subsections above)**. When obtaining power from a BellSouth service panel, protection devices and power cables must be engineered (sized) and installed by <<customer\_short\_name>>'s BellSouth Certified Supplier, with the exception that BellSouth shall engineer and install protection devices and

power cables for Adjacent Collocation. <<customer\_short\_name>>'s BellSouth Certified Supplier must also provide a copy of the engineering power specifications prior to the day on which <<customer\_short\_name>>'s equipment becomes operational. Charges for AC power shall be assessed pursuant to the rates specified in Exhibit B. AC power voltage and phase ratings shall be determined on a per location basis. At <<customer\_short\_name>>'s option, <<customer\_short\_name>> may arrange for AC power in an Adjacent Collocation arrangement from a retail provider of electrical power.

**[BellSouth Version]** If <<customer\_short\_name>> elects to install its own DC Power Plant, BellSouth shall provide Alternating Current (AC) power to feed <<customer\_short\_name>>'s DC Power Plant. Charges for AC power will be assessed per **breaker** ampere. When obtaining power from a BellSouth service panel, protection devices and power cables must be engineered (sized) and installed by <<customer\_short\_name>>'s BellSouth Certified Supplier, with the exception that BellSouth shall engineer and install protection devices and power cables for Adjacent Collocation. <<customer\_short\_name>>'s BellSouth Certified Supplier must also provide a copy of the engineering power specifications prior to the day on which <<customer\_short\_name>>'s equipment becomes operational. Charges for AC power shall be assessed pursuant to the rates specified in Exhibit B. AC power voltage and phase ratings shall be determined on a per location basis. At <<customer\_short\_name>>'s option, <<customer\_short\_name>> may arrange for AC power in an Adjacent Collocation arrangement from a retail provider of electrical power.

- 9.4 <<customer\_short\_name>> has the option to purchase power directly from an electric utility company where technically feasible and where space is available in a requested BellSouth Premises. Under such an option, <<customer\_short\_name>> is responsible for contracting with the electric utility company for its own power feed and meter, and is financially responsible for purchasing all equipment necessary to accomplish the conversion of the commercial AC power to DC power, including inverters, batteries, power boards, bus bars, BDFBs, backup power supplies and power cabling. The actual work to install this arrangement must be performed by a BellSouth Certified Supplier hired by <<customer\_short\_name>>. <<customer\_short\_name>>'s BellSouth Certified Supplier must comply with all applicable national, regional, state and local safety, electrical, fire and building codes, including the National Electric Safety Code standards, in installing this power arrangement, just as BellSouth is required to comply with these codes. <<customer\_short\_name>> must submit an application to BellSouth for the appropriate amount of collocation space that <<customer\_short\_name>> requires to install this type of power arrangement. BellSouth will evaluate the request and determine if the appropriate amount of space is available within the office for the installation of <<customer\_short\_name>>'s power equipment and facilities. This type of power arrangement must be located in an appropriate area in the central office that has been properly conditioned for the installation of power equipment and conforms to the applicable national, regional, state and local safety, electrical, fire and building codes. BellSouth shall waive the application fee or any other nonrecurring charge that would otherwise be due from a

- CLEC that decides to reconfigure an existing collocation power arrangement so as to purchase power directly from an electric utility company as provided herein. <<customer\_short\_name>> shall be responsible for the recurring charges associated with the central office space needed for collocation of this type of power arrangement, including space required to place associated power-related equipment and facilities (i.e., batteries, generator, power meter, etc.). If there is no space available for this type of power arrangement in the requested central office, BellSouth may seek a waiver of these requirements from the state Commission for the central office requested. <<customer\_short\_name>> would still have the option to order its power needs directly from BellSouth.
- 9.5 BellSouth will revise monthly recurring power charges to reflect a power upgrade, upon notification of the completion of the upgrade by <<customer\_short\_name>>'s BellSouth Certified Supplier. BellSouth will revise recurring power charges to reflect a power reduction upon BellSouth's receipt of the Power Reduction Form from <<customer\_short\_name>> certifying the completion of the power reduction including the removal of the power cabling by <<customer\_short\_name>>'s BellSouth Certified Supplier.
- 9.6 If <<customer\_short\_name>> requests a reduction in the amount of power that BellSouth is currently providing, <<customer\_short\_name>> must submit a Subsequent Application. If no modification to the Collocation Space is requested other than the reduction in power, the Power Reconfiguration Application Fee as set forth in Exhibit B will apply. If modifications are requested in addition to the reduction of power, the Subsequent Application Fee will apply. BellSouth will bill this nonrecurring fee on the date that BellSouth provides an Application Response.
- 9.7 If <<customer\_short\_name>> has grand-fathered power configurations currently served from the BellSouth main power board and requests that its power be reconfigured to connect to a BellSouth BDFB, in a specific central office, <<customer\_short\_name>> must submit a Subsequent Application. BellSouth will respond to such application within seven (7) calendar days and a Subsequent Application fee will apply for this reconfiguration to a BellSouth BDFB.
- 9.7.1 In Alabama and Louisiana, if <<customer\_short\_name>> has grandfathered power configurations currently served from the BellSouth main power board and requests that its power be reconfigured to connect to a BellSouth BDFB, in a specific central office, <<customer\_short\_name>> must submit a Subsequent Application. BellSouth will respond to such application within seven (7) calendar days and no application fee will apply [BST clarification] for this one time only power reconfiguration to a BellSouth BDFB. For any power reconfigurations thereafter, <<customer\_short\_name>> will submit a Subsequent Application and the appropriate application fee will apply.
- 9.8 Remote Site Power. BellSouth shall make available -48 Volt (-48V) DC power for <<customer\_short\_name>>'s Remote Collocation Space at a BellSouth Battery Distribution Fuse Bay (BDFB) within the Remote Site Location. The charge for

power shall be assessed as part of the recurring charge for rack/bay space. If the power requirements for <<customer\_short\_name>>'s equipment exceeds the capacity available, then such power requirements shall be assessed on an individual case basis (ICB). BellSouth will revise recurring power charges to reflect a power upgrade upon notification of the completion of the upgrade by <<customer\_short\_name>>'s BellSouth Certified Supplier. BellSouth will revise recurring power charges to reflect a power reduction upon BellSouth's receipt of the Power Reduction Form from <<customer\_short\_name>> certifying the completion of the power reduction, including the removal of the power cabling by <<customer\_short\_name>>'s BellSouth Certified Supplier.

- 9.9 Remote Site Adjacent Collocation Power. Charges for AC power will be assessed per breaker ampere per month. Rates include the provision of commercial and standby AC power, where available. When obtaining power from a BellSouth service panel, protection devices and power cables must be engineered (sized) and installed by <<customer\_short\_name>>'s BellSouth Certified Supplier, with the exception that BellSouth shall engineer and install protection devices and power cables for Adjacent Collocation. <<customer\_short\_name>>'s BellSouth Certified Supplier must also provide a copy of the engineering power specification prior to the equipment becoming operational. Charges for AC power shall be assessed pursuant to the rates specified in Exhibit B. AC power voltage and phase ratings shall be determined on a per location basis. At <<customer\_short\_name>>'s option, <<customer\_short\_name>> may arrange for AC power in an Adjacent Collocation arrangement from a retail provider of electrical power.

## **10. Insurance**

- 10.1 <<customer\_short\_name>> shall, at its sole cost and expense, procure, maintain, and keep in force insurance as specified in this Section and underwritten by insurance companies licensed to do business in the states applicable under this Agreement and having a Best's Insurance Rating of A-.
- 10.2 <<customer\_short\_name>> shall maintain the following specific coverage:
- 10.2.1 Commercial General Liability coverage in the amount of ten million dollars (\$10,000,000.00) or a combination of Commercial General Liability and Excess/Umbrella coverage totaling not less than ten million dollars (\$10,000,000.00). BellSouth shall be named as an Additional Insured on the Commercial General Liability policy as specified herein.
- 10.2.2 Statutory Workers Compensation coverage and Employers Liability coverage in the amount of one hundred thousand dollars (\$100,000.00) each accident, one hundred thousand dollars (\$100,000.00) each employee by disease, and five hundred thousand dollars (\$500,000.00) policy limit by disease.
- 10.3 All policies purchased by <<customer\_short\_name>> shall be deemed to be primary and not contributing to or in excess of any similar coverage purchased by BellSouth.

- All insurance must be in effect on or before the date equipment is delivered to Premises and shall remain in effect for the term of this Attachment or until all <<customer\_short\_name>>'s property has been removed from BellSouth's Premises, whichever period is longer. If <<customer\_short\_name>> fails to maintain required coverage, BellSouth may pay the premiums thereon and seek reimbursement of same from <<customer\_short\_name>>.
- 10.4 <<customer\_short\_name>> shall submit certificates of insurance reflecting the coverage required pursuant to this Section a minimum of ten (10) business days prior to the commencement of any work in the Collocation Space. Failure to meet this interval may result in construction and equipment installation delays. <<customer\_short\_name>> shall arrange for BellSouth to receive thirty (30) calendar days' advance notice of cancellation from <<customer\_short\_name>>'s insurance company. <<customer\_short\_name>> shall forward a certificate of insurance and notice of cancellation/non-renewal to BellSouth at the following address:
- BellSouth Telecommunications, Inc.  
Attn.: Risk Management Office - Finance  
17F54 BellSouth Center  
675 W. Peachtree Street  
Atlanta, Georgia 30375
- 10.5 <<customer\_short\_name>> must conform to recommendations made by BellSouth's fire insurance company to the extent BellSouth has agreed to, or shall hereafter agree to, such recommendations.
- 10.6 Self-Insurance. If <<customer\_short\_name>>'s net worth exceeds five hundred million dollars (\$500,000,000), <<customer\_short\_name>> may elect to request self-insurance status in lieu of obtaining any of the insurance required in Sections 9.2.1 and 9.2.2 above. <<customer\_short\_name>> shall provide audited financial statements to BellSouth thirty (30) calendar days prior to the commencement of any work in the Collocation Space. BellSouth shall then review such audited financial statements and respond in writing to <<customer\_short\_name>> in the event that self-insurance status is not granted to <<customer\_short\_name>>. If BellSouth approves <<customer\_short\_name>> for self-insurance, <<customer\_short\_name>> shall annually furnish to BellSouth, and keep current, evidence of such net worth that is attested to by one of <<customer\_short\_name>>'s corporate officers. The ability to self-insure shall continue so long as the <<customer\_short\_name>> meets all of the requirements of this Section. If <<customer\_short\_name>> subsequently no longer satisfies this Section, <<customer\_short\_name>> is required to purchase insurance as indicated by Sections 10.2.1 and 10.2.2 above.

## **11. Mechanics Liens**

- 11.1 If any mechanics lien or other liens shall be filed against property of either Party (BellSouth or <<customer\_short\_name>>), or any improvement thereon by reason of or arising out of any labor or materials furnished or alleged to have been furnished or to be furnished to or for the other Party or by reason of any changes, or additions to

said property made at the request or under the direction of the other Party, the other Party directing or requesting those changes shall, within thirty (30) business days after receipt of written notice from the Party against whose property said lien has been filed, either pay such lien or cause the same to be bonded off the affected property in the manner provided by law. The Party causing said lien to be placed against the property of the other shall also defend, at its sole cost and expense, on behalf of the other, any action, suit or proceeding which may be brought for the enforcement of such liens and shall pay any damage and discharge any judgment entered thereon.

## **12. Inspections**

- 12.1 BellSouth may conduct an inspection of <<customer\_short\_name>>'s equipment and facilities in the Collocation Space(s) prior to the activation of facilities between <<customer\_short\_name>>'s equipment and equipment of BellSouth. BellSouth may conduct an inspection if <<customer\_short\_name>> adds equipment and may otherwise conduct routine inspections at reasonable intervals mutually agreed upon by the Parties. BellSouth shall provide <<customer\_short\_name>> with a minimum of seventy-two (72) hours or three (3) business days, whichever is greater, advance notice of all such inspections. All costs of such inspection shall be borne by BellSouth.

## **13. Security and Safety Requirements**

- 13.1 Unless otherwise specified, <<customer\_short\_name>> will be required, at its own expense, to conduct a statewide investigation of criminal history records for each <<customer\_short\_name>> employee hired in the past five years being considered for work on the Premises, for the states/counties where the <<customer\_short\_name>> employee has worked and lived for the past five years. Where state law does not permit statewide collection or reporting, an investigation of the applicable counties is acceptable. <<customer\_short\_name>> shall not be required to perform this investigation if an affiliated company of <<customer\_short\_name>> has performed an investigation of the <<customer\_short\_name>> employee seeking access, if such investigation meets the criteria set forth above. This requirement will not apply if <<customer\_short\_name>> has performed a pre-employment statewide investigation of criminal history records of the <<customer\_short\_name>> employee for the states/counties where the <<customer\_short\_name>> employee has worked and lived for the past five years or, where state law does not permit a statewide investigation, an investigation of the applicable counties.
- 13.2 <<customer\_short\_name>> will be required to administer to its personnel assigned to the Premises security training either provided by BellSouth, or meeting reasonable and nondiscriminatory criteria defined by BellSouth.



- 13.3 <<customer\_short\_name>> shall provide its employees and agents with picture identification, which must be worn and visible at all times while in the Collocation Space or other areas in or around the Premises. The photo identification card shall bear, at a minimum, the employee's name and photo and <<customer\_short\_name>>'s name. BellSouth reserves the right to remove from its Premises any employee of <<customer\_short\_name>> not possessing identification issued by <<customer\_short\_name>> or who has violated any of the reasonable and nondiscriminatory criteria outlined in BellSouth's CLEC Security Training documents. <<customer\_short\_name>> shall hold BellSouth harmless for any damages resulting from such removal of its personnel from BellSouth Premises.
- 13.4 <<customer\_short\_name>> shall not assign to the Premises any personnel with records of felony criminal convictions. <<customer\_short\_name>> shall not assign to the Premises any personnel with records of misdemeanor convictions, except for misdemeanor traffic violations, without advising BellSouth of the nature and gravity of the offense(s). BellSouth reserves the right to refuse building access to any <<customer\_short\_name>> personnel who have been identified to have misdemeanor criminal convictions. Notwithstanding the foregoing, in the event that <<customer\_short\_name>> chooses not to advise BellSouth of the nature and gravity of any misdemeanor conviction, <<customer\_short\_name>> may, in the alternative, certify to BellSouth that it shall not assign to the Premises any personnel with records of misdemeanor convictions (other than misdemeanor traffic violations).
- 13.4.1 <<customer\_short\_name>> shall not knowingly assign to the Premises any individual who was a former employee and whose employment with BellSouth was terminated for a felony for which they were convicted..
- 13.4.2 <<customer\_short\_name>> shall not knowingly assign to the Premises any individual who was a former supplier of BellSouth and whose access to a Premises was revoked due to a felony for which they were convicted.
- 13.5 For each <<customer\_short\_name>> employee or agent hired by <<customer\_short\_name>> within five years of being considered for work on the Premises, who requires access to a Premises pursuant to this Attachment, <<customer\_short\_name>> shall furnish BellSouth, prior to an employee or agent gaining such access, a certification that the aforementioned background check and security training were completed. The certification will contain a statement that no felony convictions were found and certify that the employee completed the security training. If the employee's criminal history includes misdemeanor convictions, <<customer\_short\_name>> will disclose the nature of the convictions to BellSouth at that time. In the alternative, <<customer\_short\_name>> may certify to BellSouth that it shall not assign to the Premises any personnel with records of misdemeanor convictions other than misdemeanor traffic violations.
- 13.5.1 For all other <<customer\_short\_name>> employees requiring access to a Premises pursuant to this Attachment, <<customer\_short\_name>> shall furnish BellSouth, prior to an employee gaining such access, a certification that the employee is not

subject to the requirements of Section 13.5 above and that security training was completed by the employee.

13.6 [Parties Disagree]

[<<customer\_short\_name>> Version] At BellSouth's request, <<customer\_short\_name>> shall promptly remove from BellSouth's Premises any employee of <<customer\_short\_name>> BellSouth does not wish to grant access to its premises pursuant to any investigation conducted by BellSouth or prior to the initiation of an investigation if an employee of <<customer\_short\_name>> is found interfering with the property or personnel of BellSouth or another collocated telecommunications carrier **in a significant and material way**. Such investigation shall be commenced and completed by BellSouth as promptly and expeditiously as possible. The Parties shall cooperate and communicate, to the extent circumstances permit, to ensure that the Parties may take appropriate remedial measures **and so that <<customer\_short\_name>> personnel are not denied access for activity that does not have a significant and material impact and that would be more suitably addressed through disciplinary measures less likely to have a significant impact on <<customer\_short\_name>>'s daily operations.**

[BellSouth Version] At BellSouth's request, <<customer\_short\_name>> shall promptly remove from BellSouth's Premises any employee of <<customer\_short\_name>> BellSouth does not wish to grant access to its premises pursuant to any investigation conducted by BellSouth or prior to the initiation of an investigation if an employee of <<customer\_short\_name>> is found interfering with the property or personnel of BellSouth or another collocated telecommunications carrier. Such investigation shall be commenced and completed by BellSouth as promptly and expeditiously as possible. The Parties shall cooperate and communicate, to the extent circumstances permit, to ensure that the Parties may take appropriate remedial measures.

13.7 Security Violations. Each Party reserves the right to interview the other Party's employees, agents, or suppliers in the event of wrongdoing in or on BellSouth's property, or <<customer\_short\_name>>'s Collocation Space, or involving BellSouth's, <<customer\_short\_name>>'s, or another collocated telecommunications carrier's property or personnel, provided that the Party shall provide reasonable notice to the other Party's designated security representative of such interview. Each Party and its suppliers shall reasonably cooperate with the other Party's investigation into allegations of wrongdoing or criminal conduct committed by, witnessed by, or involving such Parties' employees, agents, or suppliers. Additionally, each Party reserves the right to bill the other Party for all reasonable costs associated with investigations involving its employees, agents, or suppliers if it is established and mutually agreed in good faith that such Parties' employees, agents, or suppliers are responsible for the alleged act. Each Party shall bill the other Party for the replacement or repair of property, as appropriate, which is stolen or damaged where an investigation determines the culpability of the other Party's employees, agents, or suppliers and where the other Party agrees, in good faith, with the results of such

- investigation. Each Party agrees that it shall notify the other Party in writing immediately in the event that it discovers one of its employees working on the Premises is a possible security risk. Upon request of the other Party, the Party who is the employer shall discipline consistent with its employment practices, up to and including removal from BellSouth's Premises, any employee found to have violated the security and safety requirements of this Section.
- 13.8 Use of Supplies. Unauthorized use of equipment, supplies or other property by either Party, whether or not used routinely to provide telephone service will be strictly prohibited and handled appropriately. Costs associated with such unauthorized use may be charged to the offending Party, as may be all associated investigative costs.
- 13.9 Use of Official Lines. Except for non-toll calls necessary in the performance of their work, neither Party shall use the telephones of the other Party on the Premises. Charges for unauthorized telephone calls may be charged to the offending Party, as may be all associated investigative costs.
- 13.10 Accountability. Full compliance with the Security requirements of this Section shall in no way limit the accountability of either Party to the other for the improper actions of its employees.
- 13.11 BellSouth will use its best efforts to adequately secure the area which houses <<customer\_short\_name>>'s equipment to prevent unauthorized entry. BellSouth will immediately notify <<customer\_short\_name>>'s emergency contact of any actual or attempted security breaches to the <<customer\_short\_name>>'s collocation space to the extent BellSouth becomes aware of such breaches.
- 14. Destruction of Collocation Space**
- 14.1 In the event a Collocation Space is wholly or partially damaged by fire, windstorm, tornado, flood or by similar Acts of God or force majeure circumstances beyond a Party's reasonable control to such an extent as to be rendered wholly unsuitable for <<customer\_short\_name>>'s permitted use hereunder, then either Party may elect within ten (10) calendar days after such damage, to terminate occupancy of the damaged Collocation Space, and if either Party shall so elect, by giving the other written notice of termination, both Parties shall stand released of and from further liability under the terms hereof. If the Collocation Space shall suffer only minor damage and shall not be rendered wholly unsuitable for <<customer\_short\_name>>'s permitted use, or is damaged and the option to terminate is not exercised by either Party, BellSouth covenants and agrees to proceed promptly without expense to <<customer\_short\_name>>, except for improvements not to the property of BellSouth, to repair the damage. BellSouth shall have a reasonable time within which to rebuild or make any repairs, and such rebuilding and repairing shall be subject to delays caused by storms, shortages of labor and materials, government regulations, strikes, walkouts, and causes beyond the control of BellSouth, which causes shall not be construed as limiting factors, but as exemplary only. <<customer\_short\_name>> may, at its own expense, accelerate the rebuild of its

collocated space and equipment provided however that a BellSouth Certified Supplier is used and the necessary space preparation has been completed. If <<customer\_short\_name>>'s acceleration of the project increases the cost of the project, then those additional charges will be incurred by <<customer\_short\_name>>. Where allowed and where practical, <<customer\_short\_name>> may erect a temporary facility while BellSouth rebuilds or makes repairs. In all cases where the Collocation Space shall be rebuilt or repaired, <<customer\_short\_name>> shall be entitled to an equitable abatement of rent and other charges, depending upon the unsuitability of the Collocation Space for <<customer\_short\_name>>'s permitted use, until such Collocation Space and access to necessary power is fully repaired and restored and <<customer\_short\_name>>'s equipment installed therein (but in no event later than thirty (30) calendar days after the Collocation Space is fully repaired and restored). Where <<customer\_short\_name>> has placed an Adjacent Arrangement pursuant to Section 3.4 above, <<customer\_short\_name>> shall have the sole responsibility to repair or replace said Adjacent Arrangement provided herein. Pursuant to this Section, BellSouth will restore the associated services to the Adjacent Arrangement.

## **15. Eminent Domain**

- 15.1 If the whole of a Collocation Space or Adjacent Arrangement shall be taken by any public authority under the power of eminent domain, then this Attachment shall terminate with respect to such Collocation Space or Adjacent Arrangement as of the day possession shall be taken by such public authority and rent and other charges for the Collocation Space or Adjacent Arrangement shall be paid up to that day, or the day upon which the Collocation Space can no longer be used for interconnection and access to unbundled network elements, whichever is earlier, with proportionate refund by BellSouth of such rent and charges as may have been paid in advance for a period subsequent to the date of the taking. If any part of the Collocation Space or Adjacent Arrangement shall be taken under eminent domain, BellSouth and <<customer\_short\_name>> shall each have the right to terminate this Attachment with respect to such Collocation Space or Adjacent Arrangement and declare the same null and void, by written notice of such intention to the other Party within ten (10) calendar days after such taking.

## **16. Nonexclusivity**

- 16.1 <<customer\_short\_name>> understands that this Attachment is not exclusive and that BellSouth may enter into similar agreements with other Parties. Assignment of space pursuant to all such agreements shall be determined by space availability and made on a first come, first served basis.

## **17. Notice of Non-Emergency Work**

- 17.1 BellSouth shall provide <<customer\_short\_name>> with written notice three (3) business days prior to those instances where BellSouth or its subcontractors may be performing non-emergency work that has a substantial likelihood of directly affecting the Collocation Space occupied by <<customer\_short\_name>>, or that is directly related to circuits that support <<customer\_short\_name>> equipment. BellSouth will inform <<customer\_short\_name>> by telephone of emergency related activity that BellSouth or its subcontractors may be performing that has a substantial likelihood of directly affecting the Collocation Space occupied by <<customer\_short\_name>>, or is directly related to circuits that support <<customer\_short\_name>> equipment. Notification of any emergency related activity shall be made as soon as practicable after BellSouth learns that such emergency activity is necessary so that <<customer\_short\_name>> can take any action required to monitor or protect its service.

## **ENVIRONMENTAL AND SAFETY PRINCIPLES**

The following principles provide basic guidance on environmental and safety issues when applying for and establishing Collocation arrangements.

### **1. GENERAL PRINCIPLES**

- 1.1 Compliance with Applicable Law. BellSouth and <<customer\_short\_name>> agree to comply with applicable federal, state, and local environmental and safety laws and regulations including U.S. Environmental Protection Agency (USEPA) regulations issued under the Clean Air Act (CAA), Clean Water Act (CWA), Resource Conservation and Recovery Act (RCRA), Comprehensive Environmental Response, Compensation and Liability Act (CERCLA), Superfund Amendments and Reauthorization Act (SARA), the Toxic Substances Control Act (TSCA), and OSHA regulations issued under the Occupational Safety and Health Act of 1970, as amended and NFPA and National Electrical Codes (NEC) and the NESC (Applicable Laws). Each Party shall notify the other if compliance inspections are conducted by regulatory agencies and/or citations are issued that relate to any aspect of this Attachment.
- 1.2 Notice. BellSouth and <<customer\_short\_name>> shall provide notice to the other, including Material Safety Data Sheets (MSDSs), of known and recognized physical hazards or Hazardous Chemicals existing on site or brought on site. A Hazardous Chemical inventory list is posted on an OSHA Poster and updated annually at each Central Office. This Poster is normally located near the front entrance of the building or in the lounge area. Each Party is required to provide specific notice for known potential Imminent Danger conditions. <<customer\_short\_name>> should contact 1-800-743-6737 for any BellSouth MSDS required.
- 1.3 Practices/Procedures. BellSouth may make available additional environmental control procedures for <<customer\_short\_name>> to follow when working at a Premises (See Section 2, below). These practices/procedures will represent the regular work practices required to be followed by the employees and suppliers of BellSouth for environmental protection. <<customer\_short\_name>> will require its suppliers, agents and others accessing the Premises to comply with these practices. Section 2 lists the Environmental categories where BST practices should be followed by <<customer\_short\_name>> when operating in the Premises.
- 1.4 Environmental and Safety Inspections. BellSouth reserves the right to inspect the <<customer\_short\_name>> space with proper notification. BellSouth reserves the right to stop any <<customer\_short\_name>> work operation that imposes Imminent Danger to the environment, employees or other persons in the area or Premises.
- 1.5 Hazardous Materials Brought On Site. Any hazardous materials brought into, used, stored or abandoned at the Premises by <<customer\_short\_name>> are owned by <<customer\_short\_name>>. <<customer\_short\_name>> will indemnify BellSouth

for claims, lawsuits or damages to persons or property caused by these materials. Without prior written BellSouth approval, no substantial new safety or environmental hazards can be created by <<customer\_short\_name>> or different hazardous materials used by <<customer\_short\_name>> at Premises.

<<customer\_short\_name>> must demonstrate adequate emergency response capabilities for its materials used or remaining at the Premises.

- 1.6 Spills and Releases. When contamination is discovered at a Premises, either Party discovering the condition must notify the other Party. All Spills or Releases of regulated materials will immediately be reported by <<customer\_short\_name>> to BellSouth.
- 1.7 Coordinated Environmental Plans and Permits. BellSouth and <<customer\_short\_name>> will coordinate plans, permits or information required to be submitted to government agencies, such as emergency response plans, spill prevention control and countermeasures (SPCC) plans and community reporting. If fees are associated with filing, BellSouth and <<customer\_short\_name>> will develop a cost sharing procedure. If BellSouth's permit or EPA identification number must be used, <<customer\_short\_name>> must comply with all of BellSouth's permit conditions and environmental processes, including environmental "best management practices (BMP)" (see Section 2, below) and/or selection of BST disposition vendors and disposal sites.
- 1.8 Environmental and Safety Indemnification. BellSouth and <<customer\_short\_name>> shall indemnify, defend and hold harmless the other Party from and against any claims (including, without limitation, third-party claims for personal injury or death or real or personal property damage), judgments, damages (including direct and indirect damages and punitive damages), penalties, fines, forfeitures, costs, liabilities, interest and losses arising in connection with the violation or alleged violation of any Applicable Law or contractual obligation or the presence or alleged presence of contamination arising out of the acts or omissions of the indemnifying Party, its agents, suppliers, or employees concerning its operations at the Premises.

## **2. CATEGORIES FOR CONSIDERATION OF ENVIRONMENTAL ISSUES**

- 2.1 When performing functions that fall under the following Environmental categories on BellSouth's Premises, <<customer\_short\_name>> agrees to comply with the applicable sections of the current issue of BellSouth's Environmental and Safety Methods and Procedures (M&Ps), incorporated herein by this reference. <<customer\_short\_name>> further agrees to cooperate with BellSouth to ensure that <<customer\_short\_name>>'s employees, agents, and/or suppliers are knowledgeable of and satisfy those provisions of BellSouth's Environmental M&Ps which apply to the specific Environmental function being performed by <<customer\_short\_name>>, its employees, agents and/or suppliers.

2.2 The most current version of the reference documentation must be requested from <<customer\_short\_name>>'s BellSouth Regional Contract Manager (RCM) (f/k/a Account Team Collocation Coordinator – ATCC).

<b>ENVIRONMENTAL CATEGORIES</b>	<b>ENVIRONMENTAL ISSUES</b>	<b>ADDRESSED BY THE FOLLOWING DOCUMENTATION</b>
Disposal of hazardous material or other regulated material (e.g., batteries, fluorescent tubes, solvents & cleaning materials)	Compliance with all applicable local, state, & federal laws and regulations  Pollution liability insurance  EVET approval of supplier	Std T&C 450 Fact Sheet Series 17000  Std T&C 660-3  Approved Environmental Vendor List (Contact RCM Representative)
Emergency response	Hazmat/waste release/spill fire safety emergency	Fact Sheet Series 17000 Building Emergency Operations Plan (EOP) (specific to and located on Premises)
Contract labor/outsourcing for services with environmental implications to be performed on BellSouth Premises (e.g., disposition of hazardous material/waste; maintenance of storage tanks)	Compliance with all applicable local, state, & federal laws and regulations  Performance of services in accordance with BST's environmental M&Ps  Insurance	Std T&C 450  Std T&C 450-B (Contact RCM Representative for copy of appropriate E/S M&Ps.)  Std T&C 660
Transportation of hazardous material	Compliance with all applicable local, state, & federal laws and regulations  Pollution liability insurance  EVET approval of supplier	Std T&C 450 Fact Sheet Series 17000  Std T&C 660-3  Approved Environmental Vendor List (Contact RCM Representative)



Maintenance/operations work which may produce a waste	Compliance with all applicable local, state, & federal laws and regulations	Std T&C 450
Other maintenance work	Protection of BST employees and equipment	29CFR 1910.147 (OSHA Standard) 29CFR 1910 Subpart O (OSHA Standard)
Janitorial services	All waste removal and disposal must conform to all applicable federal, state and local regulations  All Hazardous Material and Waste  Asbestos notification and protection of employees and equipment	Procurement Manager (CRES Related Matters)-BST Supply Chain Services  Fact Sheet Series 17000  GU-BTEN-001BT, Chapter 3 BSP 010-170-001BS (Hazcom)
Manhole cleaning	Compliance with all applicable local, state, & federal laws and regulations  Pollution liability insurance  EVET approval of supplier	Std T&C 450 Fact Sheet 14050 BSP 620-145-011PR Issue A, August 1996  Std T&C 660-3  Approved Environmental Vendor List (Contact RCM Representative)
Removing or disturbing building materials that may contain asbestos	Asbestos work practices	GU-BTEN-001BT, Chapter 3 For questions regarding removing or disturbing materials that contain asbestos, call the BellSouth Building Service Center: AL, MS, TN, KY & LA (local area code) 557-6194 FL, GA, NC & SC (local area code) 780-2740

### 3. DEFINITIONS

Generator. Under RCRA, the person whose act produces a Hazardous Waste, as defined in 40 CFR 261, or whose act first causes a Hazardous Waste to become subject to regulation. The Generator is legally responsible for the proper management and disposal of Hazardous Wastes in

accordance with regulations.

Hazardous Chemical. As defined in the U.S. Occupational Safety and Health (OSHA) hazard communication standard (29 CFR 1910.1200), any chemical which is a health hazard or physical hazard.

Hazardous Waste. As defined in Section 1004 of RCRA.

Imminent Danger. Any conditions or practices at a Premises which are such that a danger exists which could reasonably be expected to cause immediate death or serious harm to people or immediate significant damage to the environment or natural resources.

Spill or Release. As defined in Section 101 of CERCLA.

#### **4. ACRONYMS**

RCM – Regional Collocation Manager (f/k/a Account Team Collocation Coordinator)

BST – BellSouth Telecommunications

CRES – Corporate Real Estate and Services (formerly PS&M)

DEC/LDEC - Department Environmental Coordinator/Local Department Environmental Coordinator

E/S – Environmental/Safety

EVET - Environmental Vendor Evaluation Team

GU-BTEN-001BT - BellSouth Environmental Methods and Procedures

NESC - National Electrical Safety Codes

P&SM - Property & Services Management

Std T&C - Standard Terms & Conditions

COLLOCATION - Kentucky														Attachment: 4		Exhibit: B				
CATEGORY	RATE ELEMENTS	Interim	Zone	BCS	USOC	RATES (\$)	Svc Order Submitted Elec per LSR	Svc Order Submitted Manually per LSR	Incremental Charge - Manual Svc Order vs. Electronic-1st	Incremental Charge - Manual Svc Order vs. Electronic-Add'l	Incremental Charge - Manual Svc Order vs. Electronic-Disc 1st	Incremental Charge - Manual Svc Order vs. Electronic-Disc Add'l	OSS Rates (\$)							
													Rec	Nonrecurring		Nonrecurring Disconnect		SOME	SOMAN	SOMAN
													First	Add'l	First	Add'l				
<b>PHYSICAL COLLOCATION</b>																				
	Physical Collocation 2-Wire Cross Connect, Exchange Port 2-Wire Analog - Res			UEPSR	PE1R2	0.0333	24.68	23.68	12.14	10.95										
	Physical Collocation 2-Wire Cross Connect, Exchange Port 2-Wire Line Side PBX Trunk - Bus			UEPSP	PE1R2	0.0333	24.68	23.68	12.14	10.95										
	Physical Collocation 2-Wire Cross Connect, Exchange Port 2-Wire Voice Grade PBX Trunk - Res			UEPSE	PE1R2	0.0333	24.68	23.68	12.14	10.95										
	Physical Collocation 2-Wire Cross Connect, Exchange Port 2-Wire Analog - Bus			UEPSB	PE1R2	0.0333	24.68	23.68	12.14	10.95										
	Physical Collocation 2-Wire Cross Connect, Exchange Port 2-Wire ISDN			UEPSX	PE1R2	0.0333	24.68	23.68	12.14	10.95										
	Physical Collocation 2-Wire Cross Connect, Exchange Port 2-Wire ISDN			UEPTX	PE1R2	0.0333	24.68	23.68	12.14	10.95										
	Physical Collocation 4-Wire Cross Connect, Exchange Port 4-Wire ISDN DS1			UEPEX	PE1R4	1.48	44.23	31.98	12.81	11.57										
<b>PHYSICAL COLLOCATION</b>																				
	Physical Collocation - Initial Application Fee			CLO	PE1BA		3,773.54													
	Physical Collocation - Subsequent Application Fee			CLO	PE1CA		3,145.35													
	Physical Collocation Administrative Only - Application Fee			CLO	PE1BL		742.12													
	Physical Collocation - Space Preparation - Firm Order Processing			CLO	PE1SJ		1,206.07													
	Physical Collocation - Space Preparation - C.O. Modification per square ft.			CLO	PE1SK	2.32														
	Physical Collocation - Space Preparation, Common Systems Modifications-Cageless, per square foot			CLO	PE1SL	3.26														
	Physical Collocation - Space Preparation - Common Systems Modifications-Caged, per cage			CLO	PE1SM	110.57														
	Physical Collocation - Cable Installation, Pricing, non-recurring charge, per Entrance Cable			CLO	PE1BD		1,729.11		45.16											
	Physical Collocation - Floor Space, per sq feet			CLO	PE1PJ	7.99														
	Physical Collocation - Cable Support Structure, per Entrance Cable			CLO	PE1PM	19.86														
	Physical Collocation - Power, -48V DC Power - per Fused Amp			CLO	PE1PL	8.06														
	Physical Collocation - Power Reconfiguration Only, Application Fee	I		CLO	PE1PR		399.50													
	Physical Collocation - Power, 120V AC Power, Single Phase, per Breaker Amp			CLO	PE1FB	5.44														
	Physical Collocation - Power, 240V AC Power, Single Phase, per Breaker Amp			CLO	PE1FD	10.88														
	Physical Collocation - Power, 120V AC Power, Three Phase, per Breaker Amp			CLO	PE1FE	16.32														
	Physical Collocation - Power, 277V AC Power, Three Phase, per Breaker Amp			CLO	PE1FG	37.68														
	Physical Collocation - 2-wire cross-connect, loop, provisioning			UEANL, UEQ, UNLDX, UNCNX, UEA, UCL, UAL, UHL, UDC, UDN, UNCVX	PE1P2	0.0333	24.68	23.68	12.14	10.95										
	Physical Collocation - 4-wire cross-connect, loop, provisioning			UEA, UHL, UNCVX, UNCDX, UCL, UDL	PE1P4	0.0665	24.88	23.82	12.77	11.46										
	Physical Collocation -DS1 Cross-Connect for Physical Collocation, provisioning			WDS1L, WDS1S, UXTD1, ULDD1, USLEL, UNLD1, UEPEX, UEPDX, USL, ULC, U1TD1, UNCX	PE1P1	1.48	44.23	31.98	12.81	11.57										

COLLOCATION - Kentucky														Attachment: 4		Exhibit: B				
CATEGORY	RATE ELEMENTS	Interim	Zone	BCS	USOC	RATES (\$)	Svc Order Submitted Elec per LSR	Svc Order Submitted Manually per LSR	Incremental Charge - Manual Svc Order vs. Electronic-1st	Incremental Charge - Manual Svc Order vs. Electronic-Add'l	Incremental Charge - Manual Svc Order vs. Electronic-Disc 1st	Incremental Charge - Manual Svc Order vs. Electronic-Disc Add'l	OSS Rates (\$)							
													Rec	Nonrecurring		Nonrecurring Disconnect		SOMEC	SOMAN	SOMAN
													First	Add'l	First	Add'l				
	Physical Collocation - DS3 Cross-Connect, provisioning			UE3,U1TD3, UXTD3, UXTS1, UNC3X, UNCXS, ULDD3, U1TS1,ULDS1, UNLD3	PE1P3	18.89							41.93	30.51	14.75	11.83				
	Physical Collocation - 2-Fiber Cross-Connect			CLO, ULDO3, ULD12, ULD48, U1TO3, U1T12, U1T48, UDLO3, UDL12, UDF	PE1F2	3.75							41.93	30.51	14.76	11.84				
	Physical Collocation - 4-Fiber Cross-Connect			ULDO3, ULD12, ULD48, U1TO3, U1T12, U1T48, UDLO3, UDL12, UDF	PE1F4	6.65							51.29	39.87	19.41	16.49				
	Physical Collocation - Space enclosure, welded wire, first 100 square feet			CLO	PE1BW	184.97														
	Physical Collocation - Space enclosure, welded wire, each additional 50 square feet			CLO	PE1CW	18.14														
	Physical Collocation - Security Access System, Security System, per Central Office			CLO	PE1AX	76.10														
	Physical Collocation -Security Access System - New Card Activation, per Card Activation (First), per State			CLO	PE1A1	0.058								55.79						
	Physical Collocation-Security Access System-Administrative Change, existing Access Card, per Request, per State, per Card			CLO	PE1AA									15.64						
	Physical Collocation - Security Access System - Replace Lost or Stolen Card, per Card			CLO	PE1AR									45.74						
	Physical Collocation - Security Access - Initial Key, per Key			CLO	PE1AK									26.29						
	Physical Collocation - Security Access - Key, Replace Lost or Stolen Key, per Key			CLO	PE1AL									26.29						
	Physical Collocation - Space Availability Report, per Central Office Requested			CLO	PE1SR									2,158.67						
	Physical Collocation - CFA Information Resend Request, per premises, per request			CLO	PE1C9									77.55						
	Physical Collocation - Cable Records, per request			CLO	PE1CR									1,524.45	980.01	267.02				
	Physical Collocation, Cable Records, VG/DS0 Cable, per cable record (maximum 3600 records)			CLO	PE1CD									656.37		379.70				
	Physical Collocation, Cable Records, VG/DS0 Cable, per each 100 pair			CLO	PE1CO									9.65		11.84				
	Physical Collocation, Cable Records, DS1, per T1 TIE			CLO	PE1C1									4.52		5.54				
	Physical Collocation, Cable Records, DS3, per T3 TIE			CLO	PE1C3									15.81		19.39				
	Physical Collocation - Cable Records, Fiber Cable, per cable record (maximum 99 records)			CLO	PE1CB									169.63		154.85				
	Physical Collocation - Security Escort for Basic Time - normally scheduled work, per half hour			CLO	PE1BT									33.98	21.53					
	Physical Collocation - Security Escort for Overtime - outside of normally scheduled working hours on a scheduled work day, per half hour			CLO	PE1OT									44.26	27.81					
	Physical Collocation - Security Escort for Premium Time - outside of scheduled work day, per half hour			CLO	PE1PT									54.54	34.09					
	Physical Collocation - Virtual to Physical Collocation Relocation, per Voice Grade Circuit			CLO	PE1BV									33.00						
	Physical Collocation - Virtual to Physical Collocation Relocation, per DSO Circuit			CLO	PE1BO									33.00						
	Physical Collocation - Virtual to Physical Collocation Relocation, per DS1 Circuit			CLO	PE1B1									52.00						
	Physical Collocation - Virtual to Physical Collocation Relocation, per DS3 Circuit			CLO	PE1B3									52.00						
	Physical Collocation - Virtual to Physical Collocation In-Place, Per Voice Grade Circuit			CLO	PE1BR									23.00						

COLLOCATION - Kentucky																
CATEGORY	RATE ELEMENTS	Interim	Zone	BCS	USOC	RATES (\$)	Svc Order Submitted Elec per LSR	Svc Order Submitted Manually per LSR	Attachment: 4		Exhibit: B					
									Incremental Charge - Manual Svc Order vs. Electronic-1st	Incremental Charge - Manual Svc Order vs. Electronic-Add'l	Incremental Charge - Manual Svc Order vs. Electronic-Disc 1st	Incremental Charge - Manual Svc Order vs. Electronic-Disc Add'l				
									Rec						Nonrecurring	
						First	Add'l	First	Add'l	SOMEc	SOMAN	SOMAN	SOMAN	SOMAN	SOMAN	
	Physical Collocation Virtual to Physical Collocation In-Place, Per DSO Circuit			CLO	PE1BP	23.00										
	Physical Collocation - Virtual to Physical Collocation In-Place, Per DS1 Circuit			CLO	PE1BS	33.00										
	Physical Collocation - Virtual to Physical Collocation In-Place, per DS3 Circuit			CLO	PE1BE	37.00										
	Physical Collocation - Virtual to Physical Collocation In-Place/Relocation, space cable facilities assigned to Collocation Space, per 700 cable pairs or fraction thereof			CLO	PE1B7	592.00										
	Physical Collocation - Co-Carrier Cross Connects/Direct Connect - Fiber Cable Support Structure, per linear ft.			CLO	PE1ES	0.0012										
	Physical Collocation - Co-Carrier Cross Connect/Direct Connect - Copper/Coax Cable Support Structure, per lin. ft.			CLO	PE1DS	0.0018										
	Physical Collocation - Co-Carrier Cross Connects/Direct Connect, Application Fee, per application			CLO	PE1DT	584.20										
	Physical Collocation - Copper Entrance Cable per Cable (CO manhole to vault splice)			CLO	PE1EA	1,224.485	42.719									
	Physical Collocation - Copper Entrance Cable Installation, per 100 Pairs			CLO	PE1EB	18.102										
	Physical Collocation - Fiber Entrance Cable per Cable (CO manhole to vault splice)			CLO	PE1EC	1,028.981	42.719									
	Physical Collocation - Fiber Entrance Cable Installation, per Fiber			CLO	PE1ED	7.241										
	Physical Collocation - Application Cost, Simple Augment			CLO	PE1KS	594.98		1.21								
	Physical Collocation - Application Cost, Minor Augment			CLO	PE1KM	834.26		1.21								
	Physical Collocation - Application Cost, Intermediate Augment			CLO	PE1K1	1,059.00		1.21								
	Physical Collocation - Co-Carrier Cross Connect/Direct Connect - Fiber Cable Support Structure, per cable	I		CLO	PE1DU	535.55										
	Physical Collocation - Co-Carrier Cross Connect/Direct Connect - Copper/Coax Cable Support Structure, per cable	I		CLO	PE1DV	535.55										
<b>ADJACENT COLLOCATION</b>																
	Adjacent Collocation - Space Charge per Sq. Ft.			CLOAC	PE1JA	0.0173										
	Adjacent Collocation - Electrical Facility Charge per Linear Ft.			CLOAC	PE1JC	5.35										
	Adjacent Collocation - 2-Wire Cross-Connects			UEA,UHL,UDL,UCL	PE1P2	0.0258	24.68	23.68	12.14	10.95						
	Adjacent Collocation - 4-Wire Cross-Connects			UEA,UHL,UDL,UCL	PE1P4	0.0515	24.88	23.82	12.77	11.46						
	Adjacent Collocation - DS1 Cross-Connects			UEA,UHL,UDL,UCL	PE1P1	1.37	44.23	31.98	12.81	11.57						
	Adjacent Collocation - DS3 Cross-Connects			UEA,UHL,UDL,UCL	PE1P3	18.61	41.93	30.51	14.75	11.83						
	Adjacent Collocation - 2-Fiber Cross-Connect			CLOAC	PE1F2	3.15	41.93	30.51	14.76	11.84						
	Adjacent Collocation - 4-Fiber Cross-Connect			CLOAC	PE1F4	6.02	51.29	39.87	19.41	16.49						
	Adjacent Collocation - Application Fee			CLOAC	PE1JB		3,165.50									
	Adjacent Collocation - 120V, Single Phase Standby Power Rate per AC Breaker Amp			CLOAC	PE1FB	5.44										
	Adjacent Collocation - 240V, Single Phase Standby Power Rate per AC Breaker Amp			CLOAC	PE1FD	10.88										
	Adjacent Collocation - 120V, Three Phase Standby Power Rate per AC Breaker Amp			CLOAC	PE1FE	16.32										
	Adjacent Collocation - 277V, Three Phase Standby Power Rate per AC Breaker Amp			CLOAC	PE1FG	37.68										
<b>PHYSICAL COLLOCATION IN THE REMOTE SITE</b>																
	Physical Collocation in the Remote Site - Application Fee			CLORS	PE1RA	617.78		338.89								
	Cabinet Space in the Remote Site per Bay/ Rack			CLORS	PE1RB	219.67										
	Physical Collocation in the Remote Site - Security Access - Key			CLORS	PE1RD	26.29										
	Physical Collocation in the Remote Site - Space Availability Report per Premises Requested			CLORS	PE1SR	232.64										
	Physical Collocation in the Remote Site - Remote Site CLLI Code Request, per CLLI Code Requested			CLORS	PE1RE	75.40										
	Remote Site DLEC Data (BRSDDD), per Compact Disk, per CO			CLORS	PE1RR	233.42										
	Physical Collocation - Security Escort for Basic Time - normally scheduled work, per half hour			CLORS	PE1BT	33.98	21.53									

COLLOCATION - Kentucky														Attachment: 4		Exhibit: B						
CATEGORY	RATE ELEMENTS	Interim	Zone	BCS	USOC	RATES (\$)	Svc Order Submitted Elec per LSR	Svc Order Submitted Manually per LSR	Incremental Charge - Manual Svc Order vs. Electronic-1st	Incremental Charge - Manual Svc Order vs. Electronic-Add'l	Incremental Charge - Manual Svc Order vs. Electronic-Disc 1st	Incremental Charge - Manual Svc Order vs. Electronic-Disc Add'l	OSS Rates (\$)									
													Rec	Nonrecurring		Nonrecurring Disconnect		SOME	SOMAN	SOMAN	SOMAN	
													First	Add'l	First	Add'l						
	Physical Collocation - Security Escort for Overtime - outside of normally scheduled working hours on a scheduled work day, per half hour			CLORS	PE1OT	44.26																
	Physical Collocation - Security Escort for Premium Time - outside of scheduled work day, per half hour			CLORS	PE1PT	54.54																
<b>PHYSICAL COLLOCATION IN THE REMOTE SITE - ADJACENT</b>																						
	Remote Site-Adjacent Collocation - AC Power, per breaker amp			CLORS	PE1RS	6.27																
	Remote Site-Adjacent Collocation - Real Estate, per square foot			CLORS	PE1RT	0.134																
	Remote Site-Adjacent Collocation-Application Fee			CLORS	PE1RU	755.62																
<b>NOTE: If Security Escort and/or Add'l Engineering Fees become necessary for remote site collocation, the Parties will negotiate appropriate rates.</b>																						
<b>VIRTUAL COLLOCATION</b>																						
	Virtual Collocation - Application Fee			AMTFS	EAF	2,419.86																
	Virtual Collocation Administrative Only - Application Fee	I		AMTFS	VE1AF	742.12																
	Virtual Collocation - Cable Installation Cost, per cable			AMTFS	ESPCX	1,729.11																
	Virtual Collocation - Floor Space, per sq. ft.			AMTFS	ESPVX	7.99																
	Virtual Collocation - Power, per fused amp			AMTFS	ESPAX	8.06																
	Virtual Collocation - Cable Support Structure, per entrance cable			AMTFS	ESPSX	17.38																
	Virtual Collocation - 2-wire Cross Connects (loop)			UEANL, UEA, UDN, U DC, UAL, UHL, UCL, U EQ, UNCVX, UNCDX, UNCNX	UEAC2	0.0309																
	Virtual Collocation - 4-wire Cross Connects (loop)			UEA, UHL, UCL, UDL, UAL, UDN, UNCVX, UNCDX	UEAC4	0.0619																
	Virtual Collocation - 2-Fiber Cross Connects			UDL12, UDLO3, U1T48, U1T12, U1T03, ULDO3, ULD12, ULD48, UDF	CNC2F	3.80																
	Virtual Collocation - 4-Fiber Cross Connects			UDL12, UDLO3, U1T48, U1T12, U1T03, ULDO3, ULD12, ULD48, UDF	CNC4F	7.59																
	Virtual collocation - Special Access & UNE, cross-connect per DS1			USL, ULC, ULR, UXTD1, UNC1X, ULDD1, U1TD1, USLEL, UNLD1, UEPEX, UEPDX	CNC1X	1.48																
	Virtual collocation - Special Access & UNE, cross-connect per DS3			USL, UE3, U1TD3, UXTS1, UXTD3, UNC3X, UNCSX, ULDD3, U1TS1, ULDS1, UDLSX, UNLD3	CND3X	18.89																
	Virtual Collocation - Co-Carrier Cross Connects - Fiber Cable Support Structure, per linear foot			AMTFS	VE1CB	0.003																
	Virtual Collocation - Co-Carrier Cross Connects - Copper/Coax Cable Support Structure, per linear ft			AMTFS	VE1CD	0.0045																
	Virtual Collocation - Co-Carrier Cross Connects - Fiber Cable Support Structure, per cable			AMTFS	VE1CC	535.55																
	Virtual Collocation - Co-Carrier Cross Connects - Copper/Coax Cable Support Structure, per cable			AMTFS	VE1CE	535.55																
	Virtual Collocation Cable Records - per request			AMTFS	VE1BA	1,524.45																
	Virtual Collocation Cable Records - VG/DSO Cable, per cable record			AMTFS	VE1BB	656.37																
	Virtual Collocation Cable Records - VG/DSO Cable, per each 100 pair			AMTFS	VE1BC	9.65																
	Virtual Collocation Cable Records -DS1, per T1TIE			AMTFS	VE1BD	4.52																
	Virtual Collocation Cable Records - DS3, per T3TIE			AMTFS	VE1BE	15.81																

COLLOCATION - Kentucky															
CATEGORY	RATE ELEMENTS	Interim	Zone	BCS	USOC	RATES (\$)	Svc Order Submitted Elec per LSR	Svc Order Submitted Manually per LSR	Attachment: 4		Exhibit: B				
									Incremental Charge - Manual Svc Order vs. Electronic-1st	Incremental Charge - Manual Svc Order vs. Electronic-Add'l	Incremental Charge - Manual Svc Order vs. Electronic-Disc 1st	Incremental Charge - Manual Svc Order vs. Electronic-Disc Add'l			
						Rec	Nonrecurring		Nonrecurring Disconnect		OSS Rates (\$)				
							First	Add'l	First	Add'l	SOMEc	SOMAN	SOMAN	SOMAN	SOMAN
	Virtual Collocation Cable Records - Fiber Cable, per 99 fiber records			AMTFS	VE1BF		169.63		154.85						
	Virtual collocation - Security Escort - Basic, per half hour			AMTFS	SPTBX		33.98	21.53							
	Virtual collocation - Security Escort - Overtime, per half hour			AMTFS	SPTOX		44.26	27.81							
	Virtual collocation - Security Escort - Premium, per half hour			AMTFS	SPTPX		54.54	34.09							
	Virtual collocation - Maintenance in CO - Basic, per half hour			AMTFS	CTRLX		56.07	21.53							
	Virtual collocation - Maintenance in CO - Overtime, per half hour			AMTFS	SPTOM		73.23	27.81							
	Virtual collocation - Maintenance in CO - Premium per half hour			AMTFS	SPTPM		90.39	34.09							
	Virtual Collocation - Request Resend of CFA Information, per CLLI			AMTFS	VE1QR		77.55								
<b>VIRTUAL COLLOCATION</b>															
	Virtual Collocation - 2-wire Cross Connect, Exchange Port 2-Wire Analog - Res			UEPSR	VE1R2	0.0309	24.68	23.68	12.14	10.95					
	Virtual Collocation 2-Wire Cross Connect, Exchange Port 2-Wire Line Side PBX Trunk - Bus			UEPSP	VE1R2	0.0309	24.68	23.68	12.14	10.95					
	Virtual Collocation 2-Wire Cross Connect, Exchange Port 2-Wire Voice Grade PBX Trunk - Res			UEPSE	VE1R2	0.0309	24.68	23.68	12.14	10.95					
	Virtual Collocation 2-Wire Cross Connect, Exchange Port 2-Wire Analog Bus			UEPSB	VE1R2	0.0309	24.68	23.68	12.14	10.95					
	Virtual Collocation 2-Wire Cross Connect, Exchange Port 2-Wire ISDN			UEPSX	VE1R2	0.0309	24.68	23.68	12.14	10.95					
	Virtual Collocation 2-Wire Cross Connect, Exchange Port 2-Wire ISDN			UEPTX	VE1R2	0.0309	24.68	23.68	12.14	10.95					
	Virtual Collocation 4-Wire Cross Connect, Exchange Port 4-Wire ISDN DS1			UEPEX	VE1R4	1.48	44.23	31.98	12.81	11.57					
<b>Note: Rates displaying an "R" in Interim column are interim and subject to rate true-up as set forth in General Terms and Conditions.</b>															

**Attachment 5**

**Access to Numbers and Number Portability**



**TABLE OF CONTENTS**

**1. NON-DISCRIMINATORY ACCESS TO TELEPHONE NUMBERS .....3**

**2. LOCAL SERVICE PROVIDER NUMBER PORTABILITY - PERMANENT SOLUTION (LNP).....3**

**3. OPERATIONAL SUPPORT SYSTEM (OSS) RATES .....4**

## ACCESS TO NUMBERS AND NUMBER PORTABILITY

### 1. NON-DISCRIMINATORY ACCESS TO TELEPHONE NUMBERS

- 1.1 During the term of this Agreement, where <<customer\_short\_name>> is utilizing its own switch, <<customer\_short\_name>> shall contact the North American Numbering Plan Administrator (NANPA), or, where applicable, the relevant Number Pool Administrator for the assignment of numbering resources.
- 1.2 Where BellSouth provides local switching or resold services to <<customer\_short\_name>>, BellSouth will provide <<customer\_short\_name>> with online access to available telephone numbers as defined by applicable FCC rules and regulations on a first come first served basis. <<customer\_short\_name>> acknowledges that such access to numbers shall be in accordance with the appropriate FCC rules and regulations. <<customer\_short\_name>> may designate up to a forecasted six (6) months supply of available numbers as intermediate (an available number provided to <<customer\_short\_name>>) telephone numbers per rate center if the following conditions are met:
- 1.2.1 <<customer\_short\_name>> must: (1) indicate that all of the intermediate numbers currently held by <<customer\_short\_name>> in each rate center where <<customer\_short\_name>> will be requesting intermediate telephone numbers have six (6) or less months to exhaust; (2) supply projected monthly telephone number demand on a rate center basis for the coming twelve (12) months for each rate center where <<customer\_short\_name>> will be requesting intermediate telephone numbers; and, (3) demonstrate that the utilization level on current intermediate numbers held by <<customer\_short\_name>> in the rate center where <<customer\_short\_name>> is requesting telephone numbers has reached at least 70%. The above information will be provided by <<customer\_short\_name>> by submitting to BellSouth a fully completed “CO Code Assignments Months To Exhaust Certification Worksheet – TN Level” (“MTE Worksheet”), Appendix B to the Central Office Code (NXX) Assignments Guidelines, INC 95-0407-008 for each rate center where <<customer\_short\_name>> will be requesting intermediate telephone numbers. The utilization level is calculated by dividing all intermediate numbers currently assigned by <<customer\_short\_name>> to End Users by the total number of intermediate numbers held by <<customer\_short\_name>> in the rate center and multiplying the result by one hundred (100). After June 30, 2004, rate center utilization level must be at 75% (Part F of the MTE Worksheet).
- 1.2.2 If fulfilling <<customer\_short\_name>>’s request for intermediate numbers results in BellSouth having to submit a request for additional telephone numbers to a national numbering administrator (either NANPA CO Code Administration or NeuStar Pooling Administration or their successors), BellSouth will submit the

required numbering request to the national numbering administrator to satisfy <<customer\_short\_name>>'s request for intermediate numbers. BellSouth will also pursue all appropriate steps (including submitting a safety valve request (petition) to the appropriate Commission if the numbering request is denied by the national administrator) to satisfy <<customer\_short\_name>>'s request for intermediate numbers. In these cases, BellSouth is not obligated to fulfill the request by <<customer\_short\_name>> for intermediate numbers unless, and until, BellSouth's request for additional numbering resources is granted.

- 1.2.3 <<customer\_short\_name>> agrees to supply supporting information for any numbering request and/or safety valve request that BellSouth files pursuant to Section 1.2.2 above.
- 1.3 <<customer\_short\_name>> acknowledges that there may be instances where there is an industry shortage of available telephone numbers in a NPA. These instances occur where a jeopardy status has been declared by NANPA and the industry has determined that limiting the assignment of new numbers is the appropriate method to employ until the jeopardy can be alleviated. In such NPA jeopardy situations where assignment of new numbers is restricted as per the jeopardy guidelines developed by the industry, BellSouth may request that <<customer\_short\_name>> cancel all or a portion of its unassigned intermediate numbers. <<customer\_short\_name>> consent to BellSouth's request shall not be unreasonably withheld.
- 2. LNP**
- 2.1 The Parties will offer Number Portability in accordance with rules, regulations and guidelines adopted by the Commission, the FCC and industry fora.
- 2.2 End User Line Charge. Where <<customer\_short\_name>> subscribes to BellSouth's local switching, BellSouth shall bill and <<customer\_short\_name>> shall pay the end user line charge associated with implementing LNP as set forth in BellSouth's FCC Tariff No. 1. This charge is not subject to the resale discount set forth in Attachment 1 of this Agreement.
- 2.3 SMS Administration. The Parties will work cooperatively with other local service providers to establish and maintain contracts for the LNP Service Management System (SMS).
- 2.4 Network Architecture. The parties agree to adhere to applicable FCC Rules and Orders governing LNP network architecture.
- 2.5 Signaling. In connection with LNP, each Party agrees to use SS7 signaling in accordance with applicable FCC Rules and Orders.
- 2.6 N-1 Query. The parties agree to adhere to applicable FCC Rules and Orders governing LNP N-1 queries.

- 2.7 Porting of Reserved Numbers and Suspended Lines. Customers of each Party may port numbers, via LNP, that are in a denied state or that are on suspend status. In addition, Customers of each Party may port reserved numbers that the Customer has paid to reserve. Portable reserved numbers are identified on the Customer Service Record (CSR). In anticipation of porting from one Party to the other Party, a Party's subscriber may reserve additional telephone numbers and include them with the numbers that are subsequently ported to the other Party. It is not necessary to restore a denied number before it is ported.
- 2.8 Splitting of Number Groups. If blocks of subscriber numbers (including, but not limited to, Direct Inward Dial (DID) numbers and MultiServ groups) are split in connection with an LNP request, the Parties shall permit such splitting. BellSouth and <<customer\_short\_name>> shall offer number portability to customers for any portion of an existing block of DID numbers without being required to port the entire block of numbers. BellSouth and <<customer\_short\_name>> shall permit end-users who port a portion of DID numbers to retain DID service on the remaining portion of numbers. If a Party requests porting a range of DID numbers smaller than a whole block, that Party shall pay the applicable charges for doing so as set forth in Attachment 2 of this Agreement. In the event a rate is not available then the Parties shall negotiate a rate for such services.
- 2.9 The Parties will set LRN unconditional or 10-digit triggers where applicable. Where triggers are set, the porting Party will remove the ported number at the same time the trigger is removed.
- 2.10 A trigger order is a service order issued in advance of the porting of a number. A trigger order 1) initiates call queries to the AIN SS7 network in advance of the number being ported, and 2) provides for the new service provider to be in control of when a number ports.
- 2.11 Where triggers are not set, the Parties shall coordinate the porting of the number between service providers so as to minimize service interruptions to the End User.
- 2.12 BellSouth and <<customer\_short\_name>> will work cooperatively to implement changes to LNP process flows ordered by the FCC or as recommended by standard industry forums addressing LNP.
- 3. OSS RATES**
- 3.1 The terms, conditions and rates for OSS are as set forth in Attachments 1 and 2.

**Attachment 6**

**Pre-Ordering, Ordering, Provisioning,  
Maintenance and Repair**

**TABLE OF CONTENTS**

**1. QUALITY OF PRE-ORDERING, ORDERING, PROVISIONING, MAINTENANCE AND REPAIR.....3**

**2. ACCESS TO OPERATIONS SUPPORT SYSTEMS .....4**

**3. MISCELLANEOUS .....21**

## PRE-ORDERING, ORDERING, PROVISIONING, MAINTENANCE AND REPAIR

### 1. QUALITY OF PRE-ORDERING, ORDERING, PROVISIONING, MAINTENANCE AND REPAIR

- 1.1 Nondiscriminatory Access. BellSouth shall provide to <<customer\_short\_name>> access to its Operations Support Systems (OSS) and the necessary information contained therein in order that <<customer\_short\_name>> can perform the functions of pre-ordering, ordering, provisioning, maintenance-and repair, and billing in accordance with FCC and Commission rules and orders. Detailed guidelines for ordering and pre-ordering are set forth in the Local Ordering Handbook (LOH) on the interconnection web site, <http://interconnection.bellsouth.com/guides/html/leo.html>, for maintenance and repair at [http://www.interconnection.bellsouth.com/guides/html/other\\_guides.html](http://www.interconnection.bellsouth.com/guides/html/other_guides.html) and for billing at <http://www.interconnection.bellsouth.com/guides/html/billing.html>. Except where otherwise required by Commission order, where practicable, BellSouth will notify <<customer\_short\_name>> of changes to ordering, preordering, provisioning, maintenance and repair, and billing interfaces and business rules via the appropriate BellSouth web site thirty (30) calendar days prior to such changes. In addition, BellSouth will use its best efforts, upon <<customer\_short\_name>>'s request to BellSouth's Interconnection Services (ICS) website group at [wmag@bellsouth.com](mailto:wmag@bellsouth.com), to provide such notices via e-mail to the address specified by <<customer\_short\_name>>.
- 1.2 Regular Working Hours/Overtime. For purposes of this Agreement, BellSouth's regular working hours for provisioning are defined as follows:
- |  |  |
|--|--|
| Monday – Friday – 8:00 a.m. – 5:00 p.m. (Excluding Holidays) | (Resale/UNE non-coordinated, coordinated orders and order coordinated-time specific) |
| Saturday - 8:00 a.m. – 5:00 p.m. (Excluding Holidays)        | (Resale/UNE non-coordinated orders)  |
- 1.2.1 The above hours represent the hours, either Eastern or Central Time, of the location where the End User is located and the physical work associated with providing service to that End User is being performed.
- 1.2.2 To the extent <<customer\_short\_name>> requests provisioning of service to be performed outside BellSouth's regular working hours, or the work so requested requires BellSouth's technicians or Project Manager to work outside of regular working hours, overtime billing charges pursuant to Section A2.3.15 of BellSouth's General Subscriber Services Tariff for the applicable state shall

apply. Notwithstanding the foregoing, if such work is performed outside of regular working hours by a BellSouth technician or Project Manager during his or her scheduled shift and BellSouth does not incur any overtime charges in performing the work on behalf of <<customer\_short\_name>>, BellSouth will not assess <<customer\_short\_name>> additional charges beyond the rates and charges specified in this Agreement.

1.3

<<customer\_short\_name>> and BellSouth will utilize standard industry formats and data elements developed by the Alliance for Telecommunications Industry Solutions (“ATIS”), including without limitation to the Ordering and Billing Forum (“OBF”) (“ATIS and its associated committees”). Where standard industry formats and data elements are not developed by ATIS and its associated committees, <<customer\_short\_name>> and BellSouth may cooperatively work to pursue their development through these industry standards organizations. For non-industry standard changes that will affect systems within the scope of the Change Control Process (changes that affect external users of BellSouth’s OSS interfaces and associated manual processes and documentation) to the extent <<customer\_short\_name>> elects to address such changes <<customer\_short\_name>> will use the CCP located at [http://www.interconnection.bellsouth.com/markets/lec/ccp\\_live/index.html/main/clec.html](http://www.interconnection.bellsouth.com/markets/lec/ccp_live/index.html/main/clec.html) to address the specific requirements. When an ATIS and its associated committees standard or format is subsequently adopted, the Parties will utilize the CCP located at [http://www.interconnection.bellsouth.com/markets/lec/ccp\\_live/index.html/main/clec.html](http://www.interconnection.bellsouth.com/markets/lec/ccp_live/index.html/main/clec.html) to determine how to transition the implementation of the ATIS and its associated committees standard or format.

## **2. ACCESS TO OPERATIONS SUPPORT SYSTEMS**

2.1

Interfaces. BellSouth shall provide <<customer\_short\_name>> access to OSS functions for pre-ordering, ordering, provisioning, maintenance and repair, and billing. BellSouth shall provide access to the OSS through manual and/or electronic interfaces as described in this Attachment. It is the sole responsibility of <<customer\_short\_name>> to obtain the technical capability to access and utilize BellSouth’s OSS interfaces. Specifications for <<customer\_short\_name>>’s access and use of BellSouth’s electronic interfaces are set forth at [www.interconnection.bellsouth.com/guides/html/lens\\_tafi.html](http://www.interconnection.bellsouth.com/guides/html/lens_tafi.html) (Programming Interfaces) and are incorporated herein by reference.

2.2

For each OSS system training class offered by BellSouth, BellSouth shall make available one free seat per year. Job aids for updates to such OSS training information are available to <<customer\_short\_name>> on the BellSouth Website.

2.2.1

Prior to initial live access to interface functionality and subject to mutual agreement, the Parties shall conduct cooperative testing which will allow for the



testing of the systems, interfaces, and processes for the OSS functions as defined at the BellSouth Interconnection website for testing, <http://interconnection.bellsouth.com/clectest/index.html>, and in CCP Section 10, [http://interconnection.bellsouth.com/markets/lec/ccp\\_live/docs/bccp/ccp\\_bccp\\_guide.pdf](http://interconnection.bellsouth.com/markets/lec/ccp_live/docs/bccp/ccp_bccp_guide.pdf).

- 2.2.2 Each BellSouth interface shall be available, except for maintenance, emergency repair and scheduled downtime necessary for situations such as systems upgrades and applications releases as indicated in the OSS System Hours of Availability at [www.interconnection.bellsouth.com/oss/oss\\_hour.html](http://www.interconnection.bellsouth.com/oss/oss_hour.html), except as modified through Carrier Notification Letters, and is incorporated herein by reference twenty-four (24) hours a day, seven (7) days a week.
- 2.2.2.1 BellSouth will provide a minimum of fifteen (15) calendar days advanced notice of any scheduled maintenance and scheduled downtime outside the regularly scheduled system downtime. Maintenance shall normally be scheduled when systems experience minimum usage. Downtime for emergency repair (Type 1 System Outage) will be given within fifteen (15) minutes of when it is known via email and web posting. Non-scheduled maintenance is defined in BellSouth's Operational Understanding located at [http://www.interconnection.bellsouth.com/guides/other\\_guides/html/gopeu001/index.htm](http://www.interconnection.bellsouth.com/guides/other_guides/html/gopeu001/index.htm) as additional activity by BellSouth during a normal repair/alarm process that would require immediate maintenance action to prevent further service degradation or service interruption. This then would not lend itself to a scheduled maintenance interval or End User notification and BellSouth would employ the same process as BellSouth would use for its Retail End Users.
- 2.3 Single Point of Contact/Blanket LOA. <<customer\_short\_name>> will be the single point of contact with BellSouth for ordering activity for network elements and other services used by <<customer\_short\_name>> to provide services to its End Users, except that BellSouth may accept a request directly from another CLEC, or BellSouth, acting with authorization of the affected End User. <<customer\_short\_name>> and BellSouth shall each execute a blanket letter of authorization with respect to customer requests so that prior proof of end-user authorization will not be necessary with every request. The Parties shall each be entitled to adopt their own internal processes for verification of customer authorization for requests, provided, however, that such processes shall comply with applicable FCC and Commission rules and orders.
- 2.4 Batch Transmission. Upon request, BellSouth shall provide <<customer\_short\_name>> with pre-order information in batch transmission to the extent BellSouth makes it available or provides it to any other Telecommunications Carrier on the same terms and conditions and at the same rates.
- 2.5 Pre-Ordering. In accordance with FCC and Commission rules and orders, BellSouth will provide electronic access to its OSS and the information contained therein in order that <<customer\_short\_name>> can perform the following pre-

ordering functions: service address validation, telephone number selection, service and feature availability, due date information, customer record information and loop makeup information. Customer record information includes any and all customer specific information which will be provided as set forth in BellSouth's Customer Service Record (CSR) Job Aid and Parsed Customer Service (PCSR) Job Aid, Issue 2C-October, 2002, which is accessible via the Internet at the following web site:  
<http://www.interconnection.bellsouth.com/guides/bpobr/html/gcsrj001/index.htm>. Access to customer record information will be provided through the CLEC OSS interfaces.

2.5.1 [Parties Disagree]

[<<customer\_short\_name>> Version] **CSR information shall include customer payment history to the extent authorized or required by the FCC, Commission or End User.**

[BellSouth Version] **No Section.**

2.5.2 BellSouth shall provide electronic access to current and accurate CSR information in accordance with the BellSouth LOH which is accessible via the Internet at the following web site: <http://interconnection.bellsouth.com/guides/html/leo.html>. The response interval and average response time will be as required by SQM OSS.

2.5.3 Parsing. BellSouth shall provide parsed CSR information as set forth in BellSouth's Customer Service Record (CSR) Job Aid and Parsed Customer Service (PCSR) Job Aid, Issue 2C-October, 2002 which is accessible via the Internet at the following web site:  
<http://www.interconnection.bellsouth.com/guides/bpobr/html/gcsrj001/index.htm>.

2.5.4 BellSouth shall provide <<customer\_short\_name>> with nondiscriminatory access to the loop qualification information that is available to BellSouth, so that <<customer\_short\_name>> can make an independent judgment about whether the loop is capable of supporting the advanced services equipment that <<customer\_short\_name>> intends to install. Loop qualification information is defined as information, such as the composition of the loop material, including but not limited to: fiber optics or copper; the existence, location and type of any electronic or other equipment on the loop, including but not limited to, digital loop carrier or other remote concentration devices, feeder/distribution interfaces, bridge taps, load coils, pair-gain devices, the loop length, including the length and location of each type of transmission media; the wire gauge(s) of the loop; and the electrical parameters of the loop, which may determine the suitability of the loop for various technologies.

2.5.5 [Parties Disagree]

[<<customer\_short\_name>> Version] Subject to the same exclusions that apply to BellSouth's delivery of CSRs, <<customer\_short\_name>> shall **use best efforts to provide to BellSouth access to CSRs within an average of five (5) business days of a valid request.**

[BellSouth Version] Subject to the same exclusions that apply to BellSouth's delivery of CSRs, <<customer\_short\_name>> shall provide to BellSouth access to CSRs within **four (4) hours after request via electronic access where available. If electronic access is not available, <<customer\_short\_name>> shall provide to BellSouth paper copies of customer record information including circuit numbers associated with each telephone number where applicable within forty-eight (48) hours of a valid request.**

2.5.6 The Parties agree not to view, copy, or otherwise obtain access to the CSR information of any customer without that customer's permission. The Parties will obtain access to CSR information only in strict compliance with applicable laws, rules, or regulations of the state in which the service is provided.

2.5.6.1 LOA Request. Either Party may request that the other provide a copy of an appropriate LOA. The Parties shall use best efforts to provide such a copy within seven (7) business days.

2.5.6.2 [<<customer\_short\_name>> Version] Notice of Noncompliance. If, after receipt of a requested LOA **or, if no LOA is provided by the seventh (7th) business day after such request has been made,** the requesting Party determines that the other Party has accessed CSR information without having obtained the proper End User authorization, the requesting Party will send written notice to the other Party specifying the alleged noncompliance. **The Party receiving the notice agrees to acknowledge receipt of the notice as soon as practicable. If the Party receiving the notice does not dispute the other Party's assertion of non-compliance, the receiving Party agrees to provide the other Party with notice that appropriate corrective measures have been taken or will be taken as soon as practicable.**

[BellSouth Version] Notice of Noncompliance. If, after receipt of a requested LOA, the requesting Party determines that the other Party has accessed CSR information without having obtained the proper End User authorization, **or, if no LOA is provided by the seventh (7th) business day after such request has been made,** the requesting Party will send written notice to the other Party specifying the alleged noncompliance.

2.5.6.3 [<<customer\_short\_name>> Version] Disputes over Alleged Noncompliance. **If one Party disputes the other Party's assertion of non-compliance, that Party shall notify the other Party in writing of the basis for its assertion of compliance. If the receiving Party fails to provide the other Party with notice that appropriate corrective measures have been taken within a reasonable time or provide the other Party with proof sufficient to persuade**

**the other Party that it erred in asserting that the non-compliance, the requesting Party shall proceed pursuant to the dispute resolution provisions set forth in the General Terms and Conditions. In such instance, the Parties cooperatively shall seek expedited resolution of the dispute. All such information obtained through the process set forth in this Section 2.5.5 shall be deemed Information covered by the Proprietary and Confidential Information Section in the General Terms and Conditions of this Agreement.**

**[BellSouth Version]** Disputes over Alleged Noncompliance. In its **written notice to the other Party** the alleging Party will state **that additional applications for service may be refused, that any pending orders for service may not be completed, and/or that access to ordering systems may be suspended if such use is not corrected or ceased by the fifth (5<sup>th</sup>) calendar day following the date of the notice. In addition, the alleging Party may, at the same time, provide written notice to the person designated by the other Party to receive notices of noncompliance that the alleging Party may terminate the provision of access to ordering systems to the other Party and may discontinue the provisioning of existing services if such use is not corrected or ceased by the tenth (10<sup>th</sup>) calendar day following the date of the initial notice. If the other Party disagrees with the alleging Party's allegations of unauthorized use, the other Party shall proceed pursuant to the dispute resolution provisions set forth in the General Terms and Conditions. All such information obtained through the process set forth in this Section 2.5.5 shall be deemed Information covered by the Proprietary and Confidential Information Section in the General Terms and Conditions of this Agreement.**

## 2.6 [Parties Disagree]

**[<<customer\_short\_name>> Version]** Service Ordering and Provisioning. BellSouth will provide the capability to place orders electronically and/or manually. <<customer\_short\_name>> can determine if orders can be placed electronically for a certain product by reviewing the LOH found on BellSouth's web site located at <http://interconnection.bellsouth.com/guides/html/leo.html>. Electronic ordering will be made available via a single interface for ordering and pre-ordering or the integration of a pre-ordering and ordering interface. <<customer\_short\_name>> may integrate the EDI interface with the EDI pre-ordering interface or the TAG ordering interface with the TAG pre-ordering interface. In addition, BellSouth will provide integrated pre-ordering and ordering capability through the LENS interface for non-complex and certain complex resale service requests and certain network element requests. Facsimile and e-mail shall not be considered electronic interfaces. If at any time such interfaces are not available to make placement of an electronic local service request (LSR) possible, <<customer\_short\_name>> shall use the manual LSR process for the ordering of all services and network elements and any combination thereof. Such manual LSRs must be submitted via facsimile except when pre-arranged with BellSouth to mail manual LSRs of over one hundred

(100) pages. **In such cases**, <<customer\_short\_name>> will be assessed the lower electronically submitted OSS rate. BellSouth will make available the CLEC OSS ordering interface for the purpose of exchanging order information, including CLEC Service Order Tracking System (CSOTS) order status and completion notification, for non-complex and certain resale requests, certain network elements and network element combinations.

**[BellSouth Version]** Service Ordering and Provisioning. BellSouth will provide the capability to place orders electronically and/or manually.

<<customer\_short\_name>> can determine if orders can be placed electronically for a certain product by reviewing the LOH found on BellSouth's web site located at <http://interconnection.bellsouth.com/guides/html/leo.html>. Electronic ordering will be made available via a single interface for ordering and pre-ordering or the integration of a pre-ordering and ordering interface. <<customer\_short\_name>> may integrate the EDI interface with the EDI pre-ordering interface or the TAG ordering interface with the TAG pre-ordering interface. In addition, BellSouth will provide integrated pre-ordering and ordering capability through the LENS interface for non-complex and certain complex resale service requests and certain network element requests. Facsimile and e-mail shall not be considered electronic interfaces. If at any time such interfaces are not available to make placement of an electronic local service request (LSR) possible, <<customer\_short\_name>> shall use the manual LSR process for the ordering of all services and network elements and any combination thereof. Such manual LSRs must be submitted via facsimile except when pre-arranged with BellSouth to mail manual LSRs of over one hundred (100) pages. **In the case of outages of BellSouth's OSS interfaces**, <<customer\_short\_name>> will be assessed the lower electronically submitted OSS rate **if <<customer\_short\_name>> must submit LSRs manually during periods of systems outages by complying with the rules specified in the LOH located at <http://interconnection.bellsouth.com/guides/html/leo.html>**. BellSouth will make available the CLEC OSS ordering interface for the purpose of exchanging order information, including CLEC Service Order Tracking System (CSOTS) order status and completion notification, for non-complex and certain resale requests, certain network elements and network element combinations.

- 2.6.1 Interconnection trunking will be ordered via an ASR and shall be billed in accordance with Attachment 3.
- 2.6.2 <<customer\_short\_name>> may submit, and BellSouth will accept, orders for services and network elements as per the reasonable and nondiscriminatory requirements contained in the BellSouth LOH located at <http://interconnection.bellsouth.com/guides/html/leo.html>. Notice of changes or additions to ordering procedures resulting from new Services and Elements shall be provided to <<customer\_short\_name>> through BellSouth's Carrier Notifications which can be accessed at BellSouth's Internet site: <http://www.interconnection.bellsouth.com/notifications>.
- 2.6.3 Upon receipt of an order for a conversion, from a BellSouth retail End User to a CLEC with either UNE or Resale services, BellSouth will: (i) process disconnect

and reconnect orders, if necessary, to provision the service which shall be due-dated using the reasonable and nondiscriminatory interval guidelines set forth in Section 8 of the LOH which is accessible via the Internet at the following web site: <http://interconnection.bellsouth.com/guides/html/leo.html>, (ii) where applicable reuse the service facility for retail, resale service, or individual loop(s) and/or port(s) at the same location, and (iii) notify <<customer\_short\_name>> subsequent to the order being completed.

2.6.4 <<customer\_short\_name>> will specify on each order its Desired Due Date (DDD) for completion of that particular order. BellSouth shall assign a due date which shall be the later of the date for the interval specified in Section 8 of the LOH, located at <http://interconnection.bellsouth.com/guides/html/leo.html>, or <<customer\_short\_name>>'s DDD. BellSouth shall not complete the provisioning for that order prior to due date unless early turn-up is needed for testing purposes or <<customer\_short\_name>> otherwise consents to such early turn-up and order completion. BellSouth will make best effort to meet the due date for service requests. BellSouth will notify <<customer\_short\_name>> if the due date cannot be met and shall assign the earliest due date possible. When the DDD is less than the standard interval, <<customer\_short\_name>> shall use the expedite request field on the order. If <<customer\_short\_name>> requests that an order be expedited, BellSouth shall notify <<customer\_short\_name>> of the status of the order and the due date which shall be (1) for a non-designed order, (a) the expedite date, (b) the earliest date it can be worked after the expedite date or (c) the standard date, or (2) for an UNE order, (a) the expedite date or (b) the standard date as the DD, with the return of the Firm Order Confirmation (FOC) within the interval required by SQM O-9. Service date advancement charges shall be as set-forth in Exhibit A of Attachment 2 of this Agreement.

2.6.5 Service Date Advancement Charges (a.k.a. Expedites). For Service Date Advancement requests by <<customer\_short\_name>>, Service Date Advancement charges will apply for intervals less than the standard interval as outlined in Section 8 of the LOH, located at <http://interconnection.bellsouth.com/guides/html/leo.html>. The charges shall be as set-forth in Exhibit A of Attachment 2 of this Agreement and will apply only where Service Date Advancement has been specifically requested by the requesting Party, and the element or service provided by the other Party meets all technical specifications and is provisioned to meet those technical specifications. If <<customer\_short\_name>> accepts service on the plant test date (PTD) normal recurring charges will apply from that date but Service Date Advancement charges will only apply if <<customer\_short\_name>> previously requested the order to be expedited and the expedited DD is the same as the original PTD.

2.6.6 Missed Due Dates. In the case of a missed due date, the Parties shall work cooperatively to complete the order as soon as possible. In the event that a missed due date is one associated with a Service Date Advancement request, Service Date Advancement charges will not apply if BellSouth fails to complete the order prior to the standard interval or a negotiated interval. When the missed

due date is the fault of <<customer\_short\_name>> or its End User, subsequent order processing fees will apply. When it is a BellSouth error, subsequent order processing fees will not apply.

- 2.6.7 Cancellation Charges. If either Party cancels a request for network elements or other services, any costs incurred by the provisioning Party in conjunction with the provisioning of that request will be recovered in accordance with BellSouth's Private Line Tariff Section B2.4.14 or BellSouth's FCC No. 1 Tariff, Section 5.4, as applicable. Notwithstanding the foregoing, if <<customer\_short\_name>> places an LSR based upon BellSouth's loop makeup information, and such information is inaccurate resulting in the inability of BellSouth to provision the network elements or services requested and another compatible facility cannot be found with the transmission characteristics of the network elements or services originally requested, cancellation charges described in this Section shall not apply. Where <<customer\_short\_name>> places a single LSR for multiple network elements or services based upon loop makeup information, and information as to some, but not all, of the network elements or services is inaccurate, if BellSouth cannot provision the network elements or services that were the subject of the inaccurate loop makeup information, <<customer\_short\_name>> may cancel its request for those network elements or services without incurring cancellation charges as described in this Section. In such instance, should <<customer\_short\_name>> elect to cancel the entire LSR, cancellation charges as described in this Section shall apply to those elements and services that were not the subject of inaccurate loop makeup. Notwithstanding the foregoing, if <<customer\_short\_name>> places a single LSR for an unbundled network combination, as described in Section 5 of Attachment 2 of this Agreement, based upon BellSouth's loop makeup information, and such information is inaccurate resulting in the inability of BellSouth to provision the network elements requested in accordance with the transmission characteristics of the network elements requested, cancellation charges described in this Section shall not apply.
- 2.6.8 Resale Service Orders. Resale service orders shall be available per the BellSouth LOH which can be found at BellSouth's Internet site:  
<http://interconnection.bellsouth.com/guides/html/leo.html>.
- 2.6.8.1 BellSouth shall not require a disconnect order from an End User, <<customer\_short\_name>>, or another CLEC in order to process a <<customer\_short\_name>> order for a Resale service available under Attachment 1 to this Agreement.
- 2.6.9 FOCs, Completion Notices, Jeopardies and DLRs. BellSouth shall provide to <<customer\_short\_name>> electronic and manual interfaces for transmitting orders and receiving FOCs, Completion Notices (for electronically submitted orders only, for manual orders completions can be viewed in CSOTS), Jeopardies, Design Layout Records, Rejections and, as available, other provisioning data and information. BellSouth shall provide <<customer\_short\_name>> with a FOC for each Resale and UNE order. The information provided on the FOC will be as

described in the Product Information Packages and BellSouth LOH which can be found at BellSouth's Internet site:

<http://interconnection.bellsouth.com/guides/html/leo.html>.

- 2.6.9.1 BellSouth shall provide to <<customer\_short\_name>> a FOC within time periods as specified by SQM O-9. For a LSR in the states of Alabama, Georgia, Kentucky, Louisiana, Mississippi, and South Carolina, after the FOC is sent the order will be sent for a review of available facilities. If a facility jeopardy is found it is posted on the Pending Facilities (PF) Report found on the PMAP web site located at <https://pmap.bellsouth.com/default.aspx>. The order is then sent to the Service Advocacy Center/Outside Plant Engineering group to seek out alternative facilities and if none are found to create a work order to provide relief. Once alternative facilities are found or facilities are cleared/installed the order is cleared for completion. The process is the same for the LSRs submitted in the states of Florida, North Carolina and Tennessee where the available facilities are reviewed prior to returning the FOC.
- 2.6.10 Rejections/Errors. BellSouth shall reject and return to <<customer\_short\_name>> any local service request that BellSouth cannot provision due to technical reasons or due to missing, inaccurate or illegible information. When a LSR is rejected, BellSouth shall, in its reject notification, specifically identify and describe, using specified error codes and additional written explanation where necessary, the reasons for which the LSR was rejected. BellSouth will always use best efforts to identify all errors and any need for clarification before rejecting the LSR to <<customer\_short\_name>>, and to avoid serial requests for LSR correction or clarification. BellSouth will not be able to check for potential dependency conditions created by new data on a clarified request that might cause a serial error when the new data is inputted.
- 2.6.10.1 BellSouth will identify errors in accordance with BellSouth's LSR error messages documentation, which contains error codes applicable to a LSR and a description of the errors such codes identify. BellSouth will make available such documentation on BellSouth's interconnection web site, <http://www.interconnection.bellsouth.com/guides/html/lsr.html>. BellSouth will work cooperatively with <<customer\_short\_name>> as reasonably necessary to assist <<customer\_short\_name>> in identifying and understanding LSR errors and associated error codes. Supplemental written explanation of the reasons for the reject will be included, as necessary to pinpoint the error or need for clarification and to prevent the need for serial correction and/or clarification.
- 2.6.11.2 If a LSR is rejected more than once for error or clarification, no additional supplemental order charges shall apply.
- 2.6.11 Due dates cannot be considered confirmed until a complete and accurate Service Request has been entered into BellSouth's service request processing systems. A due date may be adjusted for an order that has been rejected for error or clarification. Serial requests for correction and/or clarification may also trigger a new due date. When a due date is impacted by an invalid clarification by



BellSouth, at <<customer\_short\_name>>'s request, BellSouth will make a best effort to honor the due date measured from the original submission of the complete and accurate service request or give the next available date.

- 2.6.12 Service Request Changes (Supplemental Service Requests). If an installation or other <<customer\_short\_name>>-requested work requires a change from the original <<customer\_short\_name>> service request in any manner while the BellSouth technician is onsite, BellSouth shall notify the appropriate <<customer\_short\_name>> ordering center designated in advance of performing the installation or other work to obtain authorization. BellSouth shall then provide <<customer\_short\_name>> an estimate of additional labor hours or materials. After all installation or other work is completed, BellSouth shall immediately notify the <<customer\_short\_name>> ordering center that approved the supplemental service request(s) of the actual labor hours or materials used.
- 2.6.12.1 If provisioning of a service request can only be partially completed due to unavailable facilities, BellSouth shall notify <<customer\_short\_name>> in accordance with the pending facilities procedures set forth in Section 2.6.14 below.
- 2.6.12.2 If <<customer\_short\_name>>'s End User requests a service change at the time of installation or other service visit performed by BellSouth technicians, BellSouth shall immediately notify <<customer\_short\_name>> at the telephone number on the service order of that request. The BellSouth technician should notify <<customer\_short\_name>> in the presence of the <<customer\_short\_name>> End User and provide an estimate of additional labor hours or materials needed so that <<customer\_short\_name>> can negotiate authority to install the requested service directly with that End User and the technician and revise appropriate ordering documents as necessary. At no time should the BellSouth representative perform any work not ordered by <<customer\_short\_name>>, even at the End User's request, without approval from the <<customer\_short\_name>> ordering center. After all installation or other work is completed, BellSouth shall immediately notify <<customer\_short\_name>> of the actual labor hours or materials used to the <<customer\_short\_name>> ordering center that authorized the supplemental service request(s).
- 2.6.13 Pending Facility Situations. BellSouth shall provide to <<customer\_short\_name>> notification of any known facility jeopardy situations when they occur via the password protected PF Report on the PMAP web site located at <http://pmap.bellsouth.com/default.aspx> and via CSOTS. When BellSouth is able to provide a new committed due date, BellSouth shall provide <<customer\_short\_name>> a FOC containing the new due date if the date is later than the original due date on a nondiscriminatory basis with itself and other CLECs.
- 2.6.14 Status. BellSouth shall provision Resale Services and UNEs as prescribed in <<customer\_short\_name>>'s service order requests. Access to FOC status on electronically submitted orders and other status states for electronically and

manually submitted orders shall be provided via CSOTS located at <https://csots.bellsouth.com>. Access to FOC status on manually submitted service order requests shall be provided on BellSouth's PMAP Internet website at <http://pmap.bellsouth.com/default.aspx>.

- 2.6.15 Lack of Facilities Notice. BellSouth shall provide notice of a lack of facilities availability in accordance with SQM P-2.
- 2.6.16 Orders placed in hold or pending status by <<customer\_short\_name>> will be held for a maximum of thirty (30) calendar days from the date the order is placed on hold. After such time, <<customer\_short\_name>> shall be required to submit a new service request. Incorrect or invalid requests returned to <<customer\_short\_name>> for correction or clarification will be held for thirty (30) calendar days. If <<customer\_short\_name>> does not return a corrected request within thirty (30) calendar days, BellSouth will cancel the request.
- 2.6.17 Testing. BellSouth shall perform all pre-testing necessary to ensure the services ordered meet the specifications outlined in the technical reference for the service being ordered. Such tests will include all of the tests that BellSouth would perform for the turnup of its own service. Upon request, BellSouth shall provide <<customer\_short\_name>> with the results from all tests when available.
- 2.6.18 <<customer\_short\_name>> and BellSouth will perform cooperative testing, if requested by <<customer\_short\_name>>, to test Services and Elements purchased by <<customer\_short\_name>> where BellSouth performs cooperative testing on like services for its retail entity. At a minimum, cooperative testing performed will include margin, attenuation and insertion loss tests. In situations where a requested test is not normally performed by BellSouth to provision a circuit, Additional Cooperative Acceptance Testing ("ACAT") charges will apply in accordance with Section 13.3.5 of BellSouth's FCC Tariff 1. In situations where a requested test is not normally performed by BellSouth to address a trouble ticket on a circuit, Additional Cooperative Acceptance Testing ("ACAT") charges will apply in accordance with Section 13.3.5 of BellSouth's FCC Tariff 1.
- 2.6.19 Both Parties shall work cooperatively if required to isolate and clear troubles that cannot be isolated to a particular Party's network.
- 2.6.20 For maintenance issues, BellSouth will perform testing with the issuance of a trouble report identifying a possible trouble condition in BellSouth's network. BellSouth will perform intrusive testing during the periods authorized by <<customer\_short\_name>> on the trouble report. Where feasible, BellSouth shall perform electronic loop tests at <<customer\_short\_name>>'s request. BellSouth shall provide <<customer\_short\_name>> with the results from all tests when available. In situations where a requested test is not normally performed by BellSouth to provision a circuit, ACAT charges will apply. If the trouble is found in BellSouth's network through the performance of the ACAT testing no ACAT charges will be charged.

- 2.6.21 Tag and Locate. BellSouth must properly and physically tag and locate all circuits, if ordered by <<customer\_short\_name>>, regardless of provisioning method employed by BellSouth. In cases where BellSouth would not otherwise dispatch to provision a circuit, and <<customer\_short\_name>> requests Tagging, <<customer\_short\_name>> will incur the Loop Tagging charges set forth in Exhibit A of Attachment 2 of this Agreement.
- 2.6.22 Suspend/Restore Orders. Upon <<customer\_short\_name>>'s request through a Suspend/Restore Order, BellSouth shall suspend or restore the functionality of any Services and Elements provided pursuant to this Agreement.
- 2.6.23 Unless otherwise ordered by <<customer\_short\_name>>, when <<customer\_short\_name>> orders services and network elements pursuant to this Agreement, all preassigned trunk or telephone numbers currently associated with those services and network elements shall be retained without loss of switched based features where such features exist. <<customer\_short\_name>> shall be responsible for ensuring that associated functions (e.g., entries to databases and 911/E911 capability) are properly ordered or retained on the service request.
- 2.6.24 Completion Notification. Upon completion of a service request submitted electronically, and once BellSouth's systems determine that the service order is completed, BellSouth shall submit to <<customer\_short\_name>>, via the same electronic interface used to submit the LSR, a completion notification that complies with the OBF/LSOG business rules and ATIS models, as adopted by the CCP. Completion information for local service requests submitted both manually and electronically is available via BellSouth's web-based system known as CSOTS.
- 2.6.25 [Parties Disagree]
- [<<customer\_short\_name>> Version] **Subject to the same exclusions that apply to BellSouth's delivery of a FOC, <<customer\_short\_name>> shall use best efforts to return a FOC to BellSouth, for purposes of porting a number, within an average of five (5) business days, for noncomplex orders, after <<customer\_short\_name>>'s receipt from BellSouth of a valid LSR.**
- [BellSouth Version] <<customer\_short\_name>> **shall return a FOC to BellSouth within thirty-six (36) hours, exclusive of Saturdays, Sundays and Holidays, after <<customer\_short\_name>>'s receipt from BellSouth of a valid LSR.**
- 2.6.26 [Parties Disagree]
- [<<customer\_short\_name>> Version] **Subject to the same exclusions that apply to BellSouth's delivering a Reject Response, <<customer\_short\_name>> shall use best efforts to provide a Reject Response to BellSouth within an average of forty-eight (48) hours, for noncomplex orders and exclusive of Saturdays,**

Sundays and Holidays, after BellSouth's submission of an LSR which is incomplete or incorrectly formatted.

[BellSouth Version] <<customer\_short\_name>> shall provide a Reject Response to BellSouth within **twenty-four (24)** hours, exclusive of Saturdays, Sundays and Holidays, after BellSouth's submission of an LSR which is incomplete or incorrectly formatted.

- 2.7 Maintenance and Repair. <<customer\_short\_name>> may report and monitor service troubles and obtain repair services from BellSouth via electronic interfaces. BellSouth provides several options for electronic trouble reporting and monitoring, including, but not limited to CPSS-TA and the following interfaces. For exchange services, BellSouth offers <<customer\_short\_name>> nondiscriminatory access to the Trouble Analysis Facilitation Interface (TAFI). In addition, BellSouth offers an industry standard, machine-to-machine Electronic Communications Trouble Administration (ECTA) Gateway interface. For designed services, BellSouth provides nondiscriminatory trouble reporting via the ECTA Gateway. BellSouth provides <<customer\_short\_name>> an estimated time to repair, as appropriate, on trouble reports. Requests for trouble repair are billed in accordance with the provisions of this Agreement. BellSouth service technicians provide to <<customer\_short\_name>> and its End Users repair service that is nondiscriminatory in relation to that provided to BellSouth and its End Users and shall receive response time priority that is at least equal to that of BellSouth and its similarly situated End Users. BellSouth will employ the Telecommunications Service Priority (TSP) System in its restoration of National Security and Emergency Preparedness (NS/EP) telecommunications services.
- 2.7.1 BellSouth and <<customer\_short\_name>> agree to adhere to BellSouth's Operational Understanding. The Operational Understanding may be assessed via the Internet at [http://www.interconnection.bellsouth.com/guides/other\\_guides/html/gopeu001/index.htm](http://www.interconnection.bellsouth.com/guides/other_guides/html/gopeu001/index.htm). For services provided through resale, BellSouth agrees to provide <<customer\_short\_name>> with scheduled maintenance for residence and small business End Users consistent with the Operational Understanding available at [http://www.interconnection.bellsouth.com/guides/other\\_guides/html/gopeu001/index.htm](http://www.interconnection.bellsouth.com/guides/other_guides/html/gopeu001/index.htm). BellSouth agrees to provide <<customer\_short\_name>> notification of Central Office conversions consistent with the Operational Understanding available at [http://www.interconnection.bellsouth.com/guides/other\\_guides/html/gopeu001/index.htm](http://www.interconnection.bellsouth.com/guides/other_guides/html/gopeu001/index.htm).
- 2.7.2 Maintenance charges for premises visits by BellSouth technicians shall be billed by <<customer\_short\_name>> to its End User, and not by BellSouth. The BellSouth technician shall: (i) contact <<customer\_short\_name>> for authorization; (ii) provide an estimate of time and materials required to <<customer\_short\_name>>; and (iii) notify <<customer\_short\_name>> if a subsequent visit is required. If additional premises work is required that cannot

be performed on that visit, BellSouth shall call <<customer\_short\_name>> to schedule another premises visit. Wherever possible, BellSouth will schedule appointments while a technician is at the premises with the End User on the line so that <<customer\_short\_name>> can schedule a new appointment with BellSouth and End User at the same time.

- 2.7.2.1 BellSouth will bill maintenance charges for premises visits to <<customer\_short\_name>> in accordance with the provisions of this Attachment.
- 2.7.3 When maintenance charges are incurred during premises visits, the BellSouth technician shall present the End User with a copy of a nonbranded warranty page that has the order number or trouble ticket number and date on it. If additional work will be necessary, BellSouth shall make an additional appointment with the <<customer\_short\_name>>'s End User.
- 2.7.4 BellSouth shall provide <<customer\_short\_name>> with access to a user interface which is functionally equivalent to the interface used by BellSouth's retail maintenance and repair centers for processing trouble reports. Such functionality shall be that described in the corresponding documentation located on the BellSouth CLEC web site at [http://www.interconnection.bellsouth.com/guides/html/lens\\_tafi/html](http://www.interconnection.bellsouth.com/guides/html/lens_tafi/html).
- 2.7.5 BellSouth supports the machine-to-machine maintenance and repair interface defined by the ANSI National Standards (T1.227, T1.228 and T1.262). Upon completion of a Joint Implementation Agreement ("JIA") with BellSouth, <<customer\_short\_name>> shall have access to this interface. The functionality of this interface shall be that described in the corresponding documentation published on the BellSouth CLEC web site at [http://www.interconnection.bellsouth.com/guides/activation/pdf/clec\\_jia.pdf](http://www.interconnection.bellsouth.com/guides/activation/pdf/clec_jia.pdf). A sample JIA is also available at this site.
- 2.7.5.1 In addition to systems and interfaces currently available, BellSouth may provide <<customer\_short\_name>> access to other maintenance and repair interfaces (as the result of the CCP or other stimuli) whose functionality matches the corresponding documentation published on the BellSouth CLEC web site at <http://www.interconnection.bellsouth.com>. Such interfaces shall not replace current interfaces prior to being addressed through CCP.
- 2.7.6 BellSouth shall make every reasonable effort to notify <<customer\_short\_name>> upon completion of a trouble report. BellSouth will close out trouble reports in accordance with SQM M&R-3.
- 2.7.7 <<customer\_short\_name>> may enter a trouble report with BellSouth when a central office feature or function is not performing. If <<customer\_short\_name>>'s circuit/telephone number that is in trouble is riding a trunk that belongs to another carrier, <<customer\_short\_name>> can submit a central office features trouble report if the circuit/telephone number has switch translations on it.

- 2.7.8 BellSouth shall advise <<customer\_short\_name>> of known central office, interoffice (such as fiber cuts), and repeater failures that are known at the time of trouble report issuance. BellSouth shall notify <<customer\_short\_name>> of switch failures pursuant to the Disaster Recovery Plan in 10 of this Agreement if applicable. <<customer\_short\_name>> will also be notified of FCC reportable events after having subscribed to the CLEC email list server in accordance with the Operational Understanding located at [http://www.interconnection.bellsouth.com/guides/other\\_guides/html/gopeu001/index.htm](http://www.interconnection.bellsouth.com/guides/other_guides/html/gopeu001/index.htm). BellSouth agrees to provide an Estimated Time To Repair (ETTR), an appointment time or commitment time, as appropriate, on all trouble reports. The Parties are responsible for making best efforts to provide prompt verbal notification to each other of significant outages or operations problems which affect the Collocation Space or Premises, to the extent it affects the Collocation Space with an estimated clearing time for restoration, if known. In addition, each Party will provide notification as soon as reasonably practical.
- 2.7.9 BellSouth will call the <<customer\_short\_name>> maintenance and repair center with notification in the event that a BellSouth maintenance and repair technician is unable to keep a scheduled repair visit within the same time frames BellSouth provides such notice to itself, its own End Users, its affiliates and to any other CLEC. If a scheduled repair visit is missed, <<customer\_short\_name>> may escalate to BellSouth for expedited repair and a revised estimated completion time.
- 2.7.9.1 Repair appointments missed due to BellSouth's fault are subject to the SQM M&R-1.
- 2.7.10 Chronic Problems. Chronic repair problems will receive specialized handling by BellSouth's Customer Wholesale Interconnection Network Services ("CWINS") Maintenance Center Chronic Group personnel. BellSouth performs maintenance analysis for chronic problems by reviewing historical trouble tickets. The chronic resolution process is for a network element, service or facility on which three (3) or more trouble tickets have been closed in a thirty (30) calendar day period, obscure or intermitten conditions or upon reasonable request by <<customer\_short\_name>>. If the analysis indicates a chronic condition exists, a chronic maintenance report will be initiated.
- 2.7.10.1 The Chronic Group will then perform a detailed analysis of the chronic maintenance report. The chronic resolution process could involve the following:
- Request for service release times
  - Circuit monitoring
  - Circuit stress testing
  - Joint <<customer\_short\_name>>/BellSouth testing
  - Component repair
  - Referral to <<customer\_short\_name>> for resolution

- 2.7.10.2 Once the chronic condition is resolved, the chronic maintenance report will be closed. If <<customer\_short\_name>> is involved in the chronic process, notification will be provided to <<customer\_short\_name>>. When <<customer\_short\_name>> determines that a chronic condition regarding a circuit or service exists, a request may be made to the CWINS Maintenance Chronic Group for review. The CWINS center will open a chronic maintenance report and perform a chronic resolution procedure. <<customer\_short\_name>> should provide any test results associated with the reported service at the time the chronic request is made.
- 2.7.10.3 The chronic process is not intended for resolving immediate trouble conditions. The resolution period will vary based on the complexity of isolating the problem. Immediate trouble conditions should be handled through the normal maintenance reporting process. A status will be provided on all <<customer\_short\_name>>-initiated chronic requests and will be closed with a call to <<customer\_short\_name>>'s maintenance service center. Once a chronic trouble has been repaired, it remains on a monitoring list for thirty (30) calendar days to ensure the problem has been corrected. Subsequent problems with a chronic circuit are handled on the original chronic ticket, allowing the customer to work from an existing ticket rather than open a new one each time they experience errors.
- 2.7.10.4 [Parties Disagree]
- [<<customer\_short\_name>> Version] Upon request from <<customer\_short\_name>>, BellSouth will disclose all available performance and maintenance history regarding the network element, service or facility subject to the Chronic Ticket.
- [BellSouthVersion] No Section.
- 2.8 Change Management. BellSouth provides a collaborative process for change management of the electronic interfaces through the CCP. Guidelines for this process are set forth in the CCP document. The CCP document may be accessed via the Internet at [http://www.interconnection.bellsouth.com/markets/lec/ccp\\_live/index.html/main/clec.html](http://www.interconnection.bellsouth.com/markets/lec/ccp_live/index.html/main/clec.html). Such CCP will provide <<customer\_short\_name>> with an opportunity to comment on proposed changes and time for BellSouth to consider and modify its proposals based on those comments.
- 2.8.1 BellSouth will provide advance notification prior to issuing new versions of BellSouth's documentation changes, including business rule changes, as described in the process flows in Section 4.0 and in Appendix G of the CCP, located at [http://www.interconnection.bellsouth.com/markets/lec/ccp\\_live/index.html/main/clec.html](http://www.interconnection.bellsouth.com/markets/lec/ccp_live/index.html/main/clec.html).
- 2.9 Electronic Interfaces. BellSouth's Versioning Policy is part of the CCP. Pursuant to the CCP, BellSouth will issue new software releases for new industry standards

for its EDI and TAG electronic interfaces. The Versioning Policy, including the appropriate notification to <<customer\_short\_name>>, is set forth in the CCP document. The CCP document may be accessed via the Internet at [http://www.interconnection.bellsouth.com/markets/lec/ccp\\_live/index.html/main/clec.html](http://www.interconnection.bellsouth.com/markets/lec/ccp_live/index.html/main/clec.html).

2.9.1 [Parties Disagree]

[<<customer\_short\_name>> Version] Rates. The Parties shall bill each other for providing OSS functionalities at the rates set forth in Exhibit A of Attachment 2 of this Agreement. <<customer\_short\_name>> shall bill BellSouth a single manual OSS charge (SOMAN) per local service request.

[BellSouth Version] Rates. BellSouth shall bill <<customer\_short\_name>> OSS rates pursuant to the terms, conditions and rates for OSS as set forth in Exhibit A of Attachment 2 of this Agreement. <<customer\_short\_name>> shall bill BellSouth a single manual OSS charge (SOMAN) per local service request associated with the 'port back' of a telephone number to BellSouth as set forth in Exhibit A of Attachment 2 of this Agreement, pursuant to the terms and conditions under which BellSouth bills <<customer\_short\_name>> for OSS, including FOC turnaround times the same as BellSouth's, due date intervals the same as BellSouth's for port out of numbers only and CSRs handled under the same terms and conditions that BellSouth is held to in providing the CSRs to <<customer\_short\_name>>. Should BellSouth desire to establish a mechanized interface with <<customer\_short\_name>> in support of the 'port back' local service requests, BellSouth shall initiate a New Business Request to <<customer\_short\_name>>.

2.9.1.1 The electronic OSS Charges rather than the manual ordering charges shall apply to a local service request submitted by <<customer\_short\_name>> when BellSouth's electronic interface normally utilized by <<customer\_short\_name>> is unavailable for reasons other than scheduled maintenance. In order to receive the electronic OSS charge <<customer\_short\_name>> must follow the procedure outlined in BellSouth's LOH, <http://interconnection.bellsouth.com/guides/html/leo.html>, for every manually submitted LSR.

3. MISCELLANEOUS

3.1 Customer Migration. Neither BellSouth nor <<customer\_short\_name>> shall prevent or delay an end-user from migrating to another carrier because of unpaid bills, denied service, or contract terms.

3.1.1 [Parties Disagree]

[<<customer\_short\_name>> Version] **In no event shall BellSouth refuse to permit, or otherwise refuse to comply with its obligations hereunder with respect to, the transition to <<customer\_short\_name>> of any End User by**



conditioning such permission or compliance upon (a) <<customer\_short\_name>>'s entry into any billing and/or collection arrangement, operational understanding or relationship with one or more of BellSouth's Affiliates (including, without limitation, BellSouth Long Distance), or any third party carrier; or (b) any applicable End User's or <<customer\_short\_name>>'s entry into any other agreement, arrangement, understanding or relationship with BellSouth or any of its Affiliates, or a third party carrier other than as expressly contemplated by this Agreement. In the event that BellSouth shall withhold or condition its permission or compliance with respect to any End User-transition matter in violation of the foregoing sentence, <<customer\_short\_name>> shall automatically and immediately be entitled to assess against and collect from BellSouth, in addition to and without prejudice to or limitation upon any other rights or remedies <<customer\_short\_name>> and/or any of its End Users may have under this Agreement, under any other agreement, instrument or document related hereto or contemplated hereby or otherwise at law or in equity against BellSouth and/or its Affiliates, or a third party carrier in respect of any such matters and/or any breach or violation of any other provision(s) of this Agreement occurring in connection therewith, an amount equal to \$1,000 per occurrence for each day. Each of BellSouth and <<customer\_short\_name>> acknowledge and agree that, insofar as it would be impossible or commercially impracticable to ascertain and fix the actual amount of damages as would be sustained by <<customer\_short\_name>> as a result of any breach by BellSouth of the foregoing provisions of this Section 3.1.1, the liquidated damage amount specified in the foregoing sentence is agreed to as a reasonable approximation of the damages likely to be sustained by <<customer\_short\_name>>, and not as a penalty, upon the occurrence and during the continuance of any such breach.

[BellSouth Version] No Section.

3.1.2

[Parties Disagree]

[<<customer\_short\_name>> Version] Mass Migration of Customers. BellSouth will cooperate with <<customer\_short\_name>> to accomplish mass migration of customers expeditiously and on terms that are reasonable and non-discriminatory. Mass migration of customer service arrangements (e.g., UNEs, Combinations, resale) will be accomplished pursuant to submission of electronic LSR or, if mutually agreed to by the Parties, by submission of a spreadsheet in a mutually agreed-upon format. Until such time as an electronic LSR process is available, a spreadsheet containing all relevant information shall be used. An electronic OSS charge shall be assessed per service arrangement migrated. This Section shall not govern bulk migration from one service arrangement to another for the same carrier or migration of a collocation space from one carrier to another.

[BellSouth Version] Mass Migration of Customers. BellSouth will cooperate with <<customer\_short\_name>> to accomplish mass migration of customers expeditiously and on terms that are reasonable and non-discriminatory.

3.1.2.1

[Parties Disagree]

[<<customer\_short\_name>>Version] **BellSouth shall only charge <<customer\_short\_name>> a TELRIC-based records change charge for the migration of customers for which no physical re-termination of circuits must be performed. The TELRIC-based records change charge is as set forth in Exhibit A of Attachment 2 of this Agreement. Such migrations shall be completed within ten (10) calendar days of an LSR or spreadsheet submission. The TELRIC-based charge for physical re-termination of circuits (including appropriate record changes (a single charge will apply)) is as set forth in Exhibit A of Attachment 2 of this Agreement. Such physical re-terminations shall be completed within ten (10) calendar days of electronic LSR or spreadsheet submission.**

[BellSouth Version] **No Section.**

3.2

Use of Facilities. When a customer of <<customer\_short\_name>> elects to discontinue service and to transfer such service to another local exchange carrier, including BellSouth, BellSouth shall have the right to reuse the facilities provided to <<customer\_short\_name>> by BellSouth. In addition, where BellSouth provides local switching, BellSouth may disconnect and reuse facilities when the facility is in a denied state (*i.e.*, service is no longer being provided over the local loop but the switch translations and interoffice facilities have not been disconnected) and BellSouth has received a request to establish new service or transfer service from a customer or a customer's CLEC at the same address served by the denied facility. BellSouth will notify <<customer\_short\_name>> that such a request has been processed after the disconnect order has been completed. Such notification will be provided via <<customer\_short\_name>>'s line loss notification report which can be found on the PMAP web site at <http://pmap.bellsouth.com/default.aspx> and is updated on a daily basis except for Sundays.

3.3

Contact Numbers. The Parties agree to provide one another with toll-free (e.g., 1-800#) contact numbers for the purpose of addressing issues related to ordering, provisioning, and maintenance and repair of services. BellSouth shall provide the contact number through BellSouth's Internet site: <http://www.interconnection.bellsouth.com/contact/index.html>. <<customer\_short\_name>> shall provide a contact number that is separate and distinct from that provide to <<customer\_short\_name>>'s End Users. In addition, BellSouth shall provide access to assistance for technical issues other than OSS training inquiries such as connectivity and passwords related to its OSS interfaces. Such assistance will be available twenty-four (24) hours a day, seven (7) days a week via designated telephone number for inquiries and e-mail/web

form (the request can be submitted either way) with guaranteed response within an hour.

- 3.4 Subscription Functions. In cases where BellSouth performs subscription functions for an interexchange carrier (IXC) (i.e., PIC and LPIC changes via Customer Account Record Exchange (CARE)), BellSouth will provide the affected IXCs with the Operating Company Number (OCN) of the local provider for the purpose of obtaining End User billing account and other End User information required under subscription requirements.
- 3.5 Service Arrangement Reconfiguration. BellSouth shall reconfigure (company initiated activity (CIA) or central office conversion) the <<customer\_short\_name>> service arrangements of <<customer\_short\_name>>'s End User for Resale services, UNEs or Combinations in accordance with the FCC's rules regarding Notice of Network Change, 47 C.F.R. 51.325 *et seq.* as well as the procedures described in the Operational Understanding located at [http://www.interconnection.bellsouth.com/guides/other\\_guides/html/gopeu001/index.htm](http://www.interconnection.bellsouth.com/guides/other_guides/html/gopeu001/index.htm) provided such reconfigurations and procedures comply with applicable FCC and Commission rules and orders. This provision shall not allow BellSouth to change the type of service ordered by <<customer\_short\_name>> (i.e. Resale, UNE or Combination) to another type of service as a result of such reconfiguration.
- 3.5 Intercept Referral Messages. The Parties shall provide an intercept referral message for the same period of time that BellSouth currently provides such a message for its own End Users. The intercept message shall be similar in format to the intercept referral message currently provided by BellSouth for its own End Users.
- 3.6 Installation/Service Visits/Additional Work. Each Party shall train and direct its employees who have contact with End Users of the other Party in the process of provisioning, maintenance or repair not to disparage the other Party or its services in any way to the other Party's End Users.
- 3.7.1 Any written "leave behind" materials that BellSouth technicians provide to <<customer\_short\_name>> End Users shall be non-branded materials that do not identify the work being performed as being by BellSouth. These materials shall include, without limitation, non-branded forms for the Customer and non-branded "not at home" cards.
- 3.7 Escalation Procedures and Contacts. BellSouth's escalation practices are provided in Appendix A and the escalation contact number list is contained in Chapter 4.0 of the Operational Understanding which is provided on the interconnection web site at [http://www.interconnection.bellsouth.com/guides/other\\_guides/html/gopeu001/index.htm](http://www.interconnection.bellsouth.com/guides/other_guides/html/gopeu001/index.htm).

- 3.8 Disputes Between <<customer\_short\_name>> and <<customer\_short\_name>>'s End Users. In general, BellSouth will not become involved in disputes between <<customer\_short\_name>> and <<customer\_short\_name>>'s End User customers. If a dispute does arise that cannot be settled without the involvement of BellSouth, <<customer\_short\_name>> shall contact the designated Service Center for assistance in the dispute resolution. BellSouth will make reasonable efforts to assist <<customer\_short\_name>> in as timely a manner as possible. BellSouth's involvement will be limited to interfacing with <<customer\_short\_name>> 's employees who are involved in the dispute resolution.
- 3.9 BellSouth shall constantly work toward resolution of pre-ordering, ordering, provisioning, maintenance and repair, billing and interface issues and disputes. <<customer\_short\_name>> must contact the appropriate BellSouth work center to record <<customer\_short\_name>>'s issue/dispute and to work with the personnel within the center to reach final resolution. Should <<customer\_short\_name>> determine that escalation is required to reach resolution, <<customer\_short\_name>> should invoke the process appropriate for that work center as spelled out in BellSouth's Operational Understanding located at <http://www.interconnection.bellsouth.com/guides> for provisioning, maintenance and repair; in Project Management located at <http://interconnection.bellsouth.com/centers/html/pm.html> for customer care project management; Section 8.0 of the Change Control Process located at [http://www.interconnection.bellsouth.com/markets/lec/ccp\\_live/index.html/main/clec.html](http://www.interconnection.bellsouth.com/markets/lec/ccp_live/index.html/main/clec.html) for interfaces and in Section 2 of Attachment 7 of this Agreement for billing.
- 3.10 The Parties will support existing NC/NCI codes to deliver the services available through this Agreement, and necessary to support all technically feasible means and levels of interconnection. The Parties will support the development of new NC/NCI codes to the extent a NC/NCI code does not exist for services available through this Agreement.
- 3.11 Project Management. Provisioning done pursuant to project management as specified in Section 8 of the LOH, located at <http://interconnection.bellsouth.com/guides/html/leo.html>, will be performed at the interval the Parties negotiated and mutually agreed to prior to the order being placed. BellSouth will offer the shortest interval available.
- 3.12 Provisioning done pursuant to project management as specified in Section 8 of the LOH will be normally be performed by project management personnel from the provisioning center. Provisioning will be performed at prices no more expensive than those prices applicable to individual service or element orders, unless <<customer\_short\_name>> negotiated to obtain project management support from BellSouth's Professional Services Group rather use the project management personnel from the provisioning center.

- 3.13 Personnel assigned by either Party to provisioning being handled on a Project Management basis shall be professional, competent, responsive and effective. Both Parties will use best efforts to resolve any problems with Project Management personnel, practices or procedures on a timely basis and in accordance with the escalation procedures set forth in this Attachment 6.
- 3.14 Continued Support of Elements or Services No Longer Offered. BellSouth shall continue to support and facilitate the use of elements and services purchased by <<customer\_short\_name>> during a reasonable period of transition, and in accordance with applicable FCC and Commission rules and orders, and any applicable tariff terms. The Parties will work cooperatively and proactively to mutually agree on a seamless transition plan to alternative service arrangements.
- 3.16 Annoyance Call Center. Where BellSouth provides switching, BellSouth will process calls made to its Annoyance Call Center and will advise <<customer\_short\_name>> when it is determined that annoyance calls are originated from one of their End User's locations. It is the responsibility of <<customer\_short\_name>> to take the corrective action necessary up to and including the disconnection of service to its End Users who make annoying calls. BellSouth shall provide the same level of Annoyance Call Center service to <<customer\_short\_name>>'s End Users as BellSouth provides to its own End Users.

**Attachment 7**

**Billing**

**TABLE OF CONTENTS**

**1. PAYMENT AND BILLING ARRANGEMENTS .....3**

**2. BILLING DISPUTES.....13**

**3. COOPERATION IN SUPPLYING BILLING INFORMATION .....15**

**4. RAO HOSTING .....15**

**5. UNBILLABLE REVENUE (CMDS/ADUF/ODUF/EODUF).....19**

**6. OPTIONAL DAILY USAGE FILE .....21**

**7. ACCESS DAILY USAGE FILE.....24**

**8. ENHANCED OPTIONAL DAILY USAGE FILE (EODUF).....26**

**Rates.....Exhibit A**

## BILLING

### 1. PAYMENT AND BILLING ARRANGEMENTS

The terms and conditions set forth in this Attachment shall apply to all services ordered and provisioned pursuant to this Agreement.

1.1 Billing. BellSouth will bill through the Carrier Access Billing System (CABS), Integrated Billing System (IBS) and/or the Customer Records Information System (CRIS) depending on the particular service(s) provided to <<customer\_short\_name>> under this Agreement. BellSouth will format all bills in Carrier Billing Output Specification (CBOS) Standard or CLUB/EDI format, depending on the type of service provided. For those services where standards have not yet been developed, BellSouth's billing format will change to comply with standards that are finalized by the applicable industry forum.

1.1.1 For any service(s) BellSouth receives from <<customer\_short\_name>>, <<customer\_short\_name>> shall continue to bill BellSouth in the same format and using the same media as it did, and to the extent any services were provided, prior to this Agreement. Any changes to format or media used will be pursuant to the mutual agreement of <<customer\_short\_name>> and BellSouth.

1.1.2 BellSouth bills will include sufficient itemization and bill detail to identify the particular elements or services provided. BellSouth shall provide <<customer\_short\_name>> a monthly bill that includes all charges incurred by and credits and/or adjustments due to <<customer\_short\_name>> for those elements or services ordered, established, utilized, discontinued or performed pursuant to this Agreement. Each bill shall set forth the quantity and description of each such element or service billed to <<customer\_short\_name>>, including USOCs and similar information, where applicable. All charges billed to <<customer\_short\_name>> must indicate the state from which such charges were incurred except in cross boundary state situations. A listing of such cross boundary exchanges is set forth in BellSouth's state specific GSST Section A3 where the serving state will be indicated.

1.1.3 [Parties Disagree]

**[<<customer\_short\_name>> Version]** The Bill Date, as defined herein, must be present on each bill transmitted by one Party to the other Party and must be a valid calendar date. **Bills should not be rendered for any charges which are incurred under this agreement when more than ninety (90) days have passed since the bill date on which those charges ordinarily would have been billed. Billed amounts for services rendered more than one (1) billing period prior to the Bill Date shall be invalid unless the billing Party identifies such billing as "back-billing" on a line-item basis. However, both Parties recognize that situations exist which would necessitate billing beyond ninety (90) days and**



**up to a limit of six (6) months after the date upon which the bill ordinarily would have been issued. These exceptions are:**

**Charges connected with jointly provided services whereby meet point billing guidelines require either party to rely on records provided by a third party and such records have not been provided in a timely manner;**

**Charges incorrectly billed due to erroneous information supplied by the non-billing Party.**

**[BellSouth Version]** The Bill Date, as defined herein, must be present on each bill transmitted by one Party to the other Party and must be a valid calendar date.

**Charges incurred under this Agreement are subject to applicable Commission rules and state statutes of limitations.**

- 1.1.4 Any switched access charges associated with interexchange carrier access to the local exchange lines resold under Attachment 1 to this Agreement will be billed by, and due to BellSouth.
- 1.1.5 BellSouth will render bills each month for lines on established bill days for each of <<customer\_short\_name>>'s accounts. Where feasible, BellSouth shall offer to render bills in electronic format. For any other billing media formats, BellSouth will offer to provide them so long as BellSouth supports their generation. If <<customer\_short\_name>> requests multiple billing media or additional copies of the bills, BellSouth will provide these at an additional cost as described in FCC Tariff 1 Section 13.3.6.3. To the extent <<customer\_short\_name>> supports the medium requested, additional copies of bills will be provided to BellSouth upon request from BellSouth at an additional cost equal to that which BellSouth would impose upon <<customer\_short\_name>>.
- 1.1.6 BellSouth will bill <<customer\_short\_name>> in advance for all services to be provided during the ensuing billing period except charges associated with service usage and nonrecurring charges, which will be billed in arrears.
- 1.1.6.1 For resold services provided under Attachment 1 to this Agreement, charges will be calculated on an individual End User account level, including, if applicable, any charge for usage or usage allowances. BellSouth will also bill <<customer\_short\_name>>, and <<customer\_short\_name>> will be responsible for and remit to BellSouth, all charges applicable to resold services including but not limited to 911 and E911 charges, End Users common line charges, federal subscriber line charges, telecommunications relay charges (TRS), and franchise fees, unless otherwise ordered by a Commission.
- 1.1.7 Except as otherwise forth in this Agreement, neither Party will perform billing and collection services for the other Party or the other Party's Affiliates solely as a result of the execution of this Agreement.

1.1.8 In the event that this Agreement or an amendment to this Agreement effects a rate change to recurring rate elements that are billed in advance, Bellsouth will make an adjustment to such recurring rates billed in advance and at the previously effective rate. The adjustment shall reflect billing at the new rates from the Effective Date of the Agreement or amendment.

1.2 **Establishing Accounts.** After submitting a credit profile and deposit, if required under Section 1.8, and receiving certification as a local exchange carrier from the appropriate regulatory agency, <<customer\_short\_name>> will provide the appropriate BellSouth Advisory Team/Local Contract Manager the necessary documentation to enable BellSouth to establish accounts for Local Interconnection, Network Elements and Other Services, Collocation and/or resold services. Such documentation shall include the Application for Master Account, if applicable, proof of authority to provide telecommunications services, the appropriate Company Code (CC) or Operating Company Number (OCN) for each state as assigned by the National Exchange Carriers Association (NECA), Carrier Identification Code (CIC), Access Customer Name and Abbreviation (ACNA), Blanket Letter of Authorization (“LOA<sup>2</sup>”), Misdirected Number form, and a tax exemption certificate, if applicable. Notwithstanding anything to the contrary in this Agreement, <<customer\_short\_name>> may not order services under a new account established in accordance with this Section 1.2 until thirty (30) calendar days after all information specified in this Section 1.2 is received from <<customer\_short\_name>>. Notwithstanding the foregoing, this Section shall have no impact on <<customer\_short\_name>> in a state, if <<customer\_short\_name>> already has established accounts with BellSouth in that state including the overall CC or OCN if <<customer\_short\_name>> is operating in more than one (1) state.

1.2.1 Upon request from <<customer\_short\_name>>, BellSouth shall provide its ACNA, CIC, OCN, and Tax Exemption Letter to establish an account for the purpose of <<customer\_short\_name>> billing to BellSouth. BellSouth will provide a LOA to <<customer\_short\_name>> upon the execution of this Agreement. Notwithstanding the foregoing, this Section shall have no impact on BellSouth, if BellSouth already has established accounts with <<customer\_short\_name>>.

1.2.2 [Parties Disagree]

[<<customer\_short\_name>> Version]\_OCN, CC, CIC, ACNA and BAN Changes. **In the event that either Party makes any corporate name change (including addition or deletion of a d/b/a), or a change in OCN, CC, CIC, ACNA or any other LEC identifier (collectively, a “LEC Change”), the changing Party shall submit written notice to the other Party. A Party may make one (1) LEC Change per state in any twelve (12) month period without charge by the other Party for updating its databases, systems, and records solely to reflect such LEC Change. In the event of any other LEC Change, such charge shall**

be at the cost-based, TELRIC compliant rate set forth in Exhibit A to this Attachment 7. LEC Changes shall be accomplished in thirty (30) calendar days and shall result in no delay or suspension of ordering or provisioning of any element or service provided pursuant to this Agreement, or access to any pre-order, order or maintenance interfaces made available by BellSouth pursuant to Attachment 6 of this Agreement. At the request of a Party, the other Party shall process and implement all system and record changes necessary to effectuate a new OCN/CC within thirty (30) calendar days. At the request of a Party, the other Party shall establish a new BAN within ten (10) calendar days.

**[BellSouth Version]** OCN, CC, CIC, ACNA and BAN Changes. If <<customer\_short\_name>> needs to change its ACNA(s)/BAN(s)/CC(s)/CIC(s)/OCN(s) under which it operates when <<customer\_short\_name>> has already been conducting business utilizing that ACNA(s)/BAN(s)/CC(s)/CIC(s)/OCN(s), <<customer\_short\_name>> shall bear all costs incurred by BellSouth to convert <<customer\_short\_name>> to the new ACNA(s)/BAN(s)/CC(s)/CIC(s)/OCN(s). ACNA/BAN/CC/CIC/OCN conversion charges include the time required to make system updates to all of <<customer\_short\_name>>'s End User customer records and will be handled by the BFR/NBR process.

- 1.3 Payment Responsibility. Subject to the provisions of Section 1 of this Attachment, each Party shall be responsible for and make payment for all charges billed. Payments made by each Party to the other Party as payment on an account will be credited to the billed Party's accounts receivable master account. Neither Party will become involved in billing disputes that may arise between the other Party and its End Users.

- 1.4 [Parties Disagree]

**[<<customer\_short\_name>> Version]** Payment Due. Payment of charges for services rendered will be due **thirty (30) calendar days from receipt or website posting of a complete and fully readable bill or within thirty (30) calendar days from receipt or website posting of a corrected or retransmitted bill in those cases where correction or retransmission is necessary for processing** and is payable in immediately available funds. Payment is considered to have been made when received by the billing Party.

**[BellSouth Version]** Payment Due. Payment for services will be due **on or before the next bill date (Payment Due Date)** and is payable in immediately available funds. Payment is considered to have been made when received by the billing Party.

- 1.4.1 If the payment due date falls on a Sunday or on a Holiday that is observed on a Monday, the payment due date shall be the first non-Holiday day following such

Sunday or Holiday. If the payment due date falls on a Saturday or on a Holiday which is observed on Tuesday, Wednesday, Thursday, or Friday, the payment due date shall be the last non-Holiday day preceding such Saturday or Holiday. If payment is not received by the payment due date, a late payment charge, as set forth in Section 1.6, below, shall apply.

- 1.5 Tax Exemption. Upon BellSouth's receipt of a tax exemption certificate, the total amount billed to <<customer\_short\_name>> will not include those taxes or fees from which <<customer\_short\_name>> is exempt. <<customer\_short\_name>> will be solely responsible for the computation, tracking, reporting and payment of all taxes and like fees associated with the services provided to the end user of <<customer\_short\_name>>.

- 1.6 [Parties Disagree]

[<<customer\_short\_name Version] Late Payment. Subject to the provisions of Section 1.7 below, if any portion of the payment is received by BellSouth after the payment due date as set forth in Section 1.2 above, or if any portion of the payment is received by the billing Party in funds that are not immediately available to the billing Party, then a late payment charge shall be due to the billing Party. The late payment charge shall be in an amount equal to not received by the payment due date multiplied by a late factor and will be applied on a per /bill basis. The late factor shall be **one (1) percent per month**. In addition to any applicable late payment charges, <<customer\_short\_name>> may be **assessed a \$20** fee for all returned checks.

[BellSouth Version] Late Payment. Subject to the provisions of Section 1.7 below, if any portion of the payment is received by BellSouth after the payment due date as set forth in Section 1.2 above, or if any portion of the payment is received by BellSouth in funds that are not immediately available to BellSouth, then a late payment charge shall be due to BellSouth. The late payment charge shall be the portion of the payment not received by the payment due date multiplied by a late factor and will be applied on a per bill basis. The late factor shall be **as set forth in Section A2 of the GSST, Section B2 of the Private Line Service Tariff or Section E2 of the Interstate Access Tariff, as appropriate**. In addition to any applicable late payment charges, <customer\_short\_name>> may be **charged** a fee for all returned checks **as set forth in Section A2 of the GSST or pursuant to the applicable state law**.

- 1.7 Suspension or Termination of Services. The procedures for suspension or termination of services are as follows:

- 1.7.1 [Parties Disagree]

[<<customer\_short\_name Version] Each Party reserves the right to suspend or terminate service in the event of prohibited, unlawful or, in the case of resold services, improper use of the other Party's facilities or service (e.g. making calls

in a manner reasonably to be expected to frighten, abuse, torment or harass another, etc.) as described under the providing Party's tariff, abuse of the other Party's facilities, or any other violation or noncompliance with this Agreement and/or each Party's tariffs where applicable. Upon detection of such use, the detecting Party will provide written notice to the other Party that additional applications for **such** service may be refused, that any pending orders for **such** service may not be completed, and/or that access to ordering systems **for such service** may be suspended if such use is not corrected or ceased by the fifteenth (15<sup>th</sup>) calendar day following the date of the notice. In addition, the detecting Party may, at the same time, provide written notice to the person designated by the other Party to receive notices of noncompliance that the detecting Party may terminate the provision of **such** existing services to the other Party if such use is not corrected or ceased by the thirtieth (30<sup>th</sup>) calendar day following the date of the initial notice. **Notwithstanding the foregoing, if the Party that receives the notice disagrees with the issuing Party's allegations of prohibited, unlawful or improper use, it shall provide written notice to the issuing Party stating the reasons therefor. Upon delivery of such notice of dispute, the foregoing provisions regarding suspension and termination will be stayed, and the Parties shall work in good faith to resolve any dispute over allegations of prohibited, unlawful or improper use. If the Parties are unable to resolve such dispute amicably, the issuing Party shall proceed, if at all, pursuant to the dispute resolution provisions set forth in the General Terms and Conditions.**

**[BellSouth Version]** Each Party reserves the right to suspend or terminate service in the event of prohibited, unlawful or, in the case of resold services, improper use of the other Party's facilities or service (e.g. making calls in a manner reasonably to be expected to frighten, abuse, torment or harass another, etc.) as described under the providing Party's tariff, abuse of the other Party's facilities, or any other violation or noncompliance with this Agreement and/or each Party's tariffs where applicable. Upon detection of such use, the detecting Party will provide written notice to the other Party that additional applications for service may be refused, that any pending orders for service may not be completed, and/or that access to ordering systems may be suspended if such use is not corrected or ceased by the fifteenth (15<sup>th</sup>) calendar day following the date of the notice. In addition, the detecting Party may, at the same time, provide written notice to the person designated by the other Party to receive notices of noncompliance that the detecting Party may terminate the provision of **all** existing services to the other Party if such use is not corrected or ceased by the thirtieth (30<sup>th</sup>) calendar day following the date of the initial notice.

#### 1.7.2

**[Parties Disagree]**

**[<<customer\_short\_name Version]** Each Party reserves the right to suspend or terminate service for nonpayment. If payment of amounts not subject to a billing dispute, as described in Section 2<sub>3</sub> is not received by the **Due Date, the billing**

**Party** may provide written notice to **the other Party** that additional applications for service may be refused, that any pending orders for service may not be completed, and/or that access to ordering systems may be suspended if payment of such amounts, **as indicated on the notice in dollars and cents**, is not received by the fifteenth (15<sup>th</sup>) calendar day following the date of the notice. In addition, **the billing Party** may, at the same time, provide written notice that **the billing Party** may discontinue the provision of existing services to **the other Party** if payment of such amounts, **as indicated on the notice (in dollars and cents)**, is not received by the thirtieth (30<sup>th</sup>) calendar day following the date of the Initial Notice.

[BellSouth Version] **BellSouth** reserves the right to suspend or terminate service for nonpayment. If payment of amounts not subject to a billing dispute, as described in Section 2, is not received by the **bill date in the month after the original bill date**, **BellSouth** will provide written notice to <<customer\_short\_name>> that additional applications for service may be refused, that any pending orders for service may not be completed, and/or that access to ordering systems may be suspended if payment of such amounts, **and all other amounts not in dispute that become past due before refusal, incompleteness or suspension**, is not received by the fifteenth (15<sup>th</sup>) calendar day following the date of the notice. In addition, **BellSouth** may, at the same time, provide written notice **to the person designated by <<customer\_short\_name>> to receive notices of noncompliance** that **BellSouth** may discontinue the provision of existing services to <<customer\_short\_name>> if payment of such amounts, **and all other amounts not in dispute that become past due before discontinuance**, is not received by the thirtieth (30<sup>th</sup>) calendar day following the date of the initial notice.

1.7.3 In the case of termination of services, all billed charges, as well as applicable termination charges, shall become due provided, however, if there are any disputed charges at the time of termination, the Parties will continue to pursue the resolution of the dispute. In the event that the Parties are unable to resolve the dispute, it will be resolved using the dispute resolution process.

1.7.4 The Parties will comply with the applicable FCC and Commission rules and orders relating to suspension, discontinuance and termination of service. Upon termination of service on the billed Party's account, such service to billed Party's end users will be denied. The billed Party is solely responsible for notifying the end user of the proposed disconnection of the service. The billing Party will reestablish service for the billed Party upon payment of all past due charges and the appropriate connection fee subject to the billing Party's normal application procedures.

1.7.5 Notices of suspension or termination of service will be delivered to the appropriate billing contact and/or address at the billed Party, as well as to the notice contacts specified in the General Terms and Conditions.



- 1.8 Deposit Policy. BellSouth reserves the right to secure the accounts of new CLECs (entities with no existing relationship with BellSouth for the purchase of wholesale services as of the Effective Date) and existing CLECs (entities with an existing relationship with BellSouth for the purchase of wholesale services as of the Effective Date) with a suitable form of security pursuant to this Section. <<customer\_short\_name>> may satisfy the requirements of this Section through the presentation of a payment guarantee with terms acceptable to BellSouth executed by a company with a credit rating of greater than or equal to 5A1. Upon request, <<customer\_short\_name>> shall complete a credit profile and provide in the form attached hereto as Exhibit B.
- 1.8.1 With the exception of new CLECs with a D&B credit rating equal to 5A1, BellSouth may secure the accounts of all new CLECs consistent with the terms set forth in subsection 1.8.2. Further, if <<customer\_short\_name>> has filed for bankruptcy protection within twelve (12) months prior to the Effective Date of this Agreement, BellSouth may treat <<customer\_short\_name>>, for purposes of establishing security on its accounts, as a new CLEC as set forth in subsection 1.8.5.
- 1.8.2 The security required by BellSouth shall take the form of cash, an Irrevocable Letter of Credit (BellSouth Form or substantially similar in substantive parts to the BellSouth Form), Surety Bond (BellSouth Form or substantially similar in substantive parts to the BellSouth Form).
- 1.8.3 [Parties Disagree]
- [<<customer\_short\_name>> Version] The amount of the security shall not exceed two month's estimated billing for new CLECs or one and one-half month's actual billing under this Agreement for existing CLECs (based on average monthly billings for the most recent six (6) month period). Interest shall accrue per the appropriate BellSouth tariff on cash deposits.
- [BellSouth Version] The amount of the security shall not exceed two (2) month's **estimated billing for new CLECs or** actual billing for existing CLECs. Interest shall accrue per the appropriate BellSouth tariff on cash deposits.
- 1.8.3.1 [Parties Disagree]
- [<<customer\_short\_name>> Version] **The amount of security due from an existing CLEC shall be reduced by amounts due <<customer\_short\_name>> by BellSouth aged over thirty (30) calendar days. BellSouth may request additional security in an amount equal to such reduction once BellSouth demonstrates a good payment history, as defined in Section 1.8.5.1, and subject to the standard set forth in Section 1.8.5.**
- [BellSouth Version]. **No Section.**

- 1.8.4 Any such security shall in no way release <<customer\_short\_name>> from its obligation to make complete and timely payments of its bills, subject to the bill dispute procedures set forth in Section 2.
- 1.8.5 BellSouth may secure the accounts of existing CLECs where an existing CLEC does not meet the following factors:
- 1.8.5.1 <<customer\_short\_name>> must have a good payment history, based upon the preceding twelve (12) month period. A good payment history shall mean that less than 10% of the non-disputed receivable balance is received over thirty (30) calendar days past the Due Date.
- 1.8.5.2 The existing CLEC's liquidity status, based upon a review of EBITDA, is EBITDA positive for the prior four (4) quarters of financials (at least one of which must be an audited financial report) excluding any nonrecurring charges or special restructuring charges.
- 1.8.5.3 If the existing CLEC has a current bond rating, such CLEC must have a bond rating of BBB or above or the existing CLEC has a current bond rating between CCC and BB and meets the following criteria for the last Fiscal Year End and for the prior four (4) quarters of reported financials:
- 1.8.5.3.1 Free cash flow positive;
- 1.8.5.3.2 Positive tangible net worth; and
- 1.8.5.3.3 Debt/tangible net worth rating of 2.5 or better.
- 1.8.6 [Parties Disagree]

[<<customer\_short\_name>> Version]. Subject to Section 1.8.7 following, in the event <<customer\_short\_name>> fails to remit to BellSouth any deposit requested pursuant to this Section **and either agreed to by <<customer\_short\_name>> or as ordered by the Commission** within thirty (30) calendar days **of such agreement or order**, service to <<customer\_short\_name>> may be terminated in accordance with the terms of Section 1.7 and subtending sections of this Attachment, and any security deposits will be applied to <<customer\_short\_name>>'s account(s).

[BellSouth Version]. Subject to Section 1.8.7 following, in the event <<customer\_short\_name>> fails to remit to BellSouth any deposit requested pursuant to this Section within thirty (30) calendar days **of <<customer\_short\_name>>'s receipt of such request**, service to <<customer\_short\_name>> may be terminated in accordance with the terms of Section 1.7 and subtending sections of this Attachment, and any security deposits will be applied to <<customer\_short\_name>>'s account(s).



## 1.8.7 [Parties Disagree]

[<<customer\_short\_name>> Version] The Parties will work together to determine the need for or amount of a reasonable deposit. **If the Parties are unable to agree, either Party** may file a petition for resolution of the dispute and both parties shall cooperatively seek expedited resolution of such dispute.

[BellSouth Version]. The Parties will work together to determine the need for or amount of a reasonable deposit. **If <<customer\_short\_name>> does not agree with the amount or need for a deposit requested by BellSouth, <<customer\_short\_name>> may file a petition with the Commissions for resolution of the dispute and both Parties shall cooperatively seek expedited resolution of such dispute. BellSouth shall not terminate service during the pendency of such a proceeding provided that <<customer\_short\_name>> posts a payment bond for the amount of the requested deposit during the pendency of the proceeding.**

1.8.8 At any such time as the provision of services to <<customer\_short\_name>> is terminated pursuant to Section 1.7, the amount of the deposit will be credited against <<customer\_short\_name>>'s account(s) and any credit balance that may remain will be refunded immediately.

## 1.8.9 [Parties Disagree]

[<<customer\_short\_name>> Version] Subject to a standard of commercial reasonableness, if a material change in the circumstances of <<customer\_short\_name>> so warrants and/or gross monthly billing has increased **more than 25%** beyond the level most recently used to determine the level of security deposit, BellSouth reserves the right to request additional security subject to the criteria set forth herein this Section 1.8. **Notwithstanding the foregoing, BellSouth shall not make such additional requests based solely on increased billing more frequently than once in any six (6) month period.**

[BellSouth Version] Subject to a standard of commercial reasonableness, if a material change in the circumstances of <<customer\_short\_name>> so warrants and/or gross monthly billing has increased beyond the level most recently used to determine the level of security deposit, BellSouth reserves the right to request additional security subject to the criteria set forth in this Section 1.8.

1.8.10 BellSouth shall refund, release or return any security, including all accrued interest, if any, within thirty (30) calendar days of its determination that such security is no longer required by the terms of this Section 1.8 or within thirty (30) calendar days of <<customer\_short\_name>> establishing that it satisfies the standards set forth in Section 1.8.4. <<customer\_short\_name>> may make the requisite showing in a letter directed to the Notices recipients set forth in the

General Terms and Conditions of this Agreement. <<customer\_short\_name>> shall attach supporting financial reports to such letter and such documents shall be accorded confidential treatment, in accordance with Section 12 of the General Terms and Conditions, unless such documents are otherwise publicly available.

- 1.9 Notices. All bills and notices regarding billing matters, including notices relating to security deposits, suspension or termination of services, and rejection of additional orders shall be forwarded to the billing contacts and/or addresses designated by each Party in the establishment of its billing accounts.

- 1.9.1 [Parties Disagree]

[<<customer\_short\_name>> Version] Notices sent pursuant to this Attachment 7 also shall be sent via certified mail to the individual(s) listed in the Notices provision of the General Terms and Conditions of this Agreement.

[BellSouth Version] **BellSouth's Initial Notice to <<customer\_short\_name>> that additional applications for service may be refused, that any pending orders for service may not be completed, and/or that access to ordering systems may be suspended if payment of such amounts, and all other amounts not in dispute that become past due before refusal, incompleteness or suspension, is not received by the fifteenth (15<sup>th</sup>) calendar day following the date of the notice is system generated and will only be supplied to <<customer\_short\_name>>'s billing contact. Notices, not system generated, of security deposits and suspension or termination of services also shall be sent via certified mail to the individual(s) listed in the Notices provision of the General Terms and Conditions of this Agreement. Such notices must be sent in accordance with the time frames set forth in Section 1.7.**

- 1.10 Rates. Rates for Optional Daily Usage File (ODUF), Access Daily Usage File (ADUF), Enhanced Optional Daily Usage File (EODUF) and Centralized Message Distribution Service (CMDS) are set out in Exhibit A to this Attachment. If no rate is identified in this Attachment, the rate for the specific service or function will be as set forth in applicable BellSouth tariff or as negotiated by the Parties upon request by either Party.

## 2. BILLING DISPUTES

- 2.1 Each Party agrees to notify the other Party in writing electronically upon the discovery of a billing dispute. Each Party shall report all billing disputes to the other Party using either the Mass Dispute spreadsheet format for multiple disputes or the Billing Adjustment Request (BAR) form attached hereto as Exhibit B.

- 2.1.1 Confirmation of the receipt of a dispute filed via the BAR form or multiple disputes filed via the Mass Dispute spreadsheet format will be sent by the billing Party to the disputing Party via the same medium used in filing the dispute(s). An automatic response will be provided for those filed electronically and a response will be provided within three (3) business days for those filed via fax. Both

Parties will use the Claim Number inserted on the BAR or the Mass Dispute spreadsheet format as the indicator of the appropriate dispute in question.

- 2.1.2 All Valid Disputes, as defined in Section 2.3 below, shall be posted so as to remove disputed amounts from the collections process prior to that process being initiated.
- 2.1.3 All Valid Disputes, as defined in Section 2.3 below, shall be posted so as to remove disputed amounts from the collections process prior to that process being initiated.
- 2.1.4 Upon request by either Party, the other Party will provide a spreadsheet containing a current list of open disputes along with the requesting Party's audit/claim number listed on the BAR form, the requesting Party's audit/claim number that is assigned to the dispute, and the disputed dollar amount. The Parties shall engage in mutually agreed upon meetings, no less frequent than quarterly, if requested by either Party, to discuss the status of the open disputes. If the billed Party disagrees with the resolution of the dispute by the billing Party, the Parties agree to use the existing escalation procedures between the Parties to resolve the dispute. If the Parties are unable to resolve the dispute through escalation, either Party may initiate the dispute resolution process.
- 2.1.5 To the extent necessary in order to resolve billing disputes, the Parties shall engage in face-to-face meetings no more frequently than every six (6) months, unless otherwise mutually agreed by the Parties, for the purpose of resolving billing disputes. Unless otherwise mutually agreed upon by the Parties the meeting shall be held at a mutually convenient time at a BellSouth location, selected by BellSouth, to which <<customer\_short\_name>> agrees to travel at its expense.
- 2.1.6 In the event of a billing dispute, the Parties will endeavor to resolve the dispute within sixty (60) calendar days of the notification date. BellSouth has provided a contact name and escalation spreadsheet by appropriate center based upon service type of the dispute at <http://interconnection.bellsouth.com/forms/html/billing&collections.html> to assist in this effort. If the Parties are unable within the sixty (60) calendar day period to reach resolution, then the unresolved dispute will be resolved in accordance with the dispute resolution provisions in the General Terms and Conditions of this Agreement.
- 2.1.7 Notwithstanding the foregoing, new billing disputes may not be filed pertaining to a bill when a period of two (2) years from the bill issue date has elapsed.
- 2.2 For purposes of this Section, a billing dispute means a reported dispute of a specific amount of money actually billed by either Party. The dispute must be clearly explained by the disputing Party and, to the extent possible, supported by relevant, written documentation (including e.g. reference to or copies of the relevant bill pages), which clearly shows the basis for disputing charges (Valid

Dispute). Examples of written document considered relevant include, but are not limited to: the number of minutes the disputing Party believes were properly and improperly billed, the rate the disputing Party believes was erroneously applied and that which it believes was applicable, the factor the disputing Party believes was erroneously applied and that which it believes was applicable, etc. All reasonable requests for additional relevant information made by one Party to another shall be honored. The billed Party may withhold payment of such disputed amounts but late payment charges and interest will be assessed per Section 2.4 below, pending resolution of the dispute. These late payment charges must be disputed until the initial dispute is resolved. Claims by the billed Party for damages of any kind will not be considered a billing dispute for purposes of this Section. If the billing dispute is resolved in favor of the billing Party, the disputing Party will make payment of any of the disputed amount owed to the billing Party within thirty (30) calendar days. If the billing dispute is resolved in favor of the billed Party, any credits due to the billed Party, pursuant to the billing dispute, will be applied to the billed Party's account by the billing Party within thirty (30) calendar days.

- 2.3 If a Party disputes a charge and does not pay such charge by the payment due date, or if a payment or any portion of a payment is received by either Party after the payment due date, or if a payment or any portion of a payment is received in funds which are not immediately available to the other Party, then a late payment charge-where applicable, shall be assessed. Such late payment charge shall be calculated in accordance with Section 1.6. There will be no late payment charges on disputed amounts, if the withholding Party prevails in the billing dispute.

### **3. COOPERATION IN SUPPLYING BILLING INFORMATION**

- 3.1 BellSouth shall cooperate with and provide all information reasonably requested by <<customer\_short\_name>> to aid in the accurate and timely billing of access and reciprocal compensation (including compensation for ISP-bound traffic) to BellSouth and any third party carriers, including BellSouth Affiliates.

### **4. RAO HOSTING**

- 4.1 Remote Accounting Office (“RAO”) Hosting, Calling Card and Third Number Settlement System (CATS) and Non-Intercompany Settlement System (NICS) services provided to <<customer\_short\_name>> by BellSouth will be in accordance with the methods and practices regularly applied by BellSouth to its own operations during the term of this Agreement, including such revisions as may be made from time to time by BellSouth and for which BellSouth will provide <<customer\_short\_name>> with thirty (30) calendar days’ advanced notice of such revisions.
- 4.2 <<customer\_short\_name>> shall furnish all relevant information required by BellSouth for the provision of RAO Hosting, CATS and NICS.

- 4.3 Charges or credits, as applicable, will be applied by BellSouth to <<customer\_short\_name>> on a monthly basis in arrears. Amounts due (excluding adjustments) are payable within thirty (30) calendar days of receipt of the billing statement.
- 4.4 <<customer\_short\_name>> must have its own unique hosted RAO code. Where BellSouth is the selected CMDS interfacing host, <<customer\_short\_name>> must request that BellSouth establish a unique hosted RAO code for <<customer\_short\_name>>. Such request shall be in writing to the BellSouth RAO Hosting coordinator and must be submitted at least eight (8) weeks prior to provision of services pursuant to this Section. Services shall commence on a date mutually agreed by the Parties.
- 4.5 BellSouth will receive messages from <<customer\_short\_name>> that are to be processed by BellSouth, another LEC in the BellSouth region or a LEC outside the BellSouth region. <<customer\_short\_name>> shall send all messages to BellSouth no later than sixty (60) calendar days after the message date.
- 4.6 BellSouth will perform invoice sequence checking, standard EMI format editing, and balancing of message data with the EMI trailer record counts on all data received from <<customer\_short\_name>>.
- 4.7 All data received from <<customer\_short\_name>> that is to be processed or billed by another LEC within the BellSouth region will be distributed to that LEC in accordance with the Agreement(s) in effect between BellSouth and the involved LEC.
- 4.8 All data received from <<customer\_short\_name>> that is to be placed on the CMDS network for distribution outside the BellSouth region will be handled in accordance with the agreement(s) in effect between BellSouth and its connecting contractor.
- 4.9 BellSouth will receive messages from the CMDS network that are destined to be processed by <<customer\_short\_name>> and will forward them to <<customer\_short\_name>> on a daily basis for processing.
- 4.10 Transmission of message data between BellSouth and <<customer\_short\_name>> will be via CONNECT:Direct or CONNECT:Enterprise Client utilizing secure File Transfer Protocol (FTP).
- 4.10.1 Data circuits (private line or dial-up) will be required between BellSouth and <<customer\_short\_name>> for the purpose of data transmission when utilizing CONNECT:Direct. Where a dedicated line is required, <<customer\_short\_name>> will be responsible for ordering the circuit and coordinating the installation with BellSouth. <<customer\_short\_name>> will also be responsible for any charges associated with this line. CSU/DSU equipment required on the BellSouth end to attach the line to the mainframe

computer and to transmit data will be the responsibility of <<customer\_short\_name>>. Where a dial-up facility is required, dial circuits will be installed in the BellSouth data center by BellSouth and the associated charges assessed to <<customer\_short\_name>>. Additionally, all message toll charges associated with the use of the dial circuit by <<customer\_short\_name>> will be the responsibility of <<customer\_short\_name>>. Associated equipment on the BellSouth end, including a modem, will be the responsibility of BellSouth. All equipment, including modems and software, that is required on the <<customer\_short\_name>> end for the purpose of data transmission will be the responsibility of <<customer\_short\_name>>.

- 4.10.2 If <<customer\_short\_name>> utilizes CONNECT:Enterprise Client for data file transmission, purchase of the CONNECT:Enterprise Client software will be the responsibility of <<customer\_short\_name>>.
- 4.11 All messages and related data exchanged between BellSouth and <<customer\_short\_name>> will be formatted for EMI formatted records and packed between appropriate EMI header and trailer records in accordance with accepted industry standards.
- 4.12 <<customer\_short\_name>> will maintain recorded message detail necessary to recreate files provided to BellSouth for a period of three (3) calendar months beyond the related message dates.
- 4.13 Should it become necessary for <<customer\_short\_name>> to send data to BellSouth more than sixty (60) calendar days past the message date(s), <<customer\_short\_name>> will notify BellSouth in advance of the transmission of the data. BellSouth will work with its connecting contractor and/or <<customer\_short\_name>>, where necessary, to notify all affected LECs.
- 4.14 Should an error be detected by the EMI format edits performed by BellSouth on data received from <<customer\_short\_name>>, the entire pack containing the affected data will not be processed by BellSouth. BellSouth will notify <<customer\_short\_name>> of the error. <<customer\_short\_name>> will correct the error(s) and will resend the entire pack to BellSouth for processing. In the event that an out-of-sequence condition occurs on subsequent packs, <<customer\_short\_name>> will resend these packs to BellSouth after the pack containing the error has been successfully reprocessed by BellSouth.
- 4.15 In association with message distribution service, BellSouth will provide <<customer\_short\_name>> with associated intercompany settlements reports (CATS and NICS) as appropriate.
- 4.16 Notwithstanding anything in this Agreement to the contrary, in no case shall either Party be liable to the other for any direct or consequential damages incurred as a result of the obligations set out in this Section.

4.17 RAO Compensation.

- 4.17.1 Rates for message distribution service provided by BellSouth for <<customer\_short\_name>> are set forth in Exhibit A.
- 4.17.2 Rates for data transmission associated with message distribution service are set forth in Exhibit A.

4.18 Intercompany Settlements Messages.

- 4.18.1 Intercompany Settlements Messages facilitate the settlement of revenues associated with traffic originated from or billed by <<customer\_short\_name>> as a facilities based provider of local exchange telecommunications services outside the BellSouth region. Only traffic that originates in one Bell operating territory and bills in another Bell operating territory is included. Traffic that originates and bills within the same Bell operating territory will be settled on a local basis between <<customer\_short\_name>> and the involved company(ies), unless that company is participating in NICS.
- 4.18.2 Both traffic that originates outside the BellSouth region by <<customer\_short\_name>> and is billed within the BellSouth region, and traffic that originates within the BellSouth region and is billed outside the BellSouth region by <<customer\_short\_name>>, is covered by CATS. Also covered is traffic that either is originated by or billed by <<customer\_short\_name>>, involves a company other than <<customer\_short\_name>>, qualifies for inclusion in the CATS settlement, and is not originated or billed within the BellSouth region (NICS).
- 4.18.3 Once <<customer\_short\_name>> is operating within the BellSouth territory, revenues associated with calls originated and billed within the BellSouth region will be settled via NICS.
- 4.18.4 BellSouth will receive the monthly NICS reports from Telcordia on behalf of <<customer\_short\_name>>. BellSouth will distribute copies of these reports to <<customer\_short\_name>> on a monthly basis.
- 4.18.5 BellSouth will receive the monthly CATS reports from Telcordia on behalf of <<customer\_short\_name>>. BellSouth will distribute copies of these reports to <<customer\_short\_name>> on a monthly basis.
- 4.18.6 BellSouth will collect the revenue earned by <<customer\_short\_name>> from the Bell operating company in whose territory the messages are billed via CATS, less a per message billing and collection fee of five cents (\$0.05), on behalf of <<customer\_short\_name>>. BellSouth will remit the revenue billed by <<customer\_short\_name>> to the Bell operating company in whose territory the messages originated, less a per message billing and collection fee of five cents (\$0.05), on behalf on <<customer\_short\_name>>. These two amounts will be

netted together by BellSouth and the resulting charge or credit issued to <<customer\_short\_name>> monthly via a monthly Carrier Access Billing System (CABS) miscellaneous bill.

- 4.18.7 BellSouth will collect the revenue earned by <<customer\_short\_name>> within the BellSouth territory from another CLEC also within the BellSouth territory (NICS) where the messages are billed, less a per message billing and collection fee of five cents (\$0.05), on behalf of <<customer\_short\_name>>. BellSouth will remit the revenue billed by <<customer\_short\_name>> within the BellSouth region to the CLEC also within the BellSouth region, where the messages originated, less a per message billing and collection fee of five cents (\$0.05). These two amounts will be netted together by BellSouth and the resulting charge or credit issued to <<customer\_short\_name>> monthly via a monthly CABS miscellaneous bill.
- 4.18.8 BellSouth and <<customer\_short\_name>> agree that monthly netted amounts of less than fifty dollars (\$50.00) will not be settled.

## **5. UNBILLABLE REVENUE (CMDS/ADUF/ODUF/EODUF)**

- 5.1 Recording Failure(s)
- 5.1.1 When BellSouth carries or switches calls and loses or fails to make a recording, regardless of whether <<customer\_short\_name>> or BellSouth are performing the billing function, BellSouth shall notify <<customer\_short\_name>> of the amount of estimated <<customer\_short\_name>> unbillable revenue in accordance with Section 5.3. BellSouth shall compensate <<customer\_short\_name>> for this unbillable revenue within three (3) bill periods. Such compensation shall be net of revenue BellSouth demonstrates it would have received for services provided to <<customer\_short\_name>>, if any, but for which BellSouth could not render bills as a result of any recording loss(es).
- 5.1.2 The term “unbillable” refers to a message or service that cannot be billed to the correct <<customer\_short\_name>> customer.
- 5.2 Lost, Damaged, or Destroyed Message Data
- 5.2.1 When <<customer\_short\_name>> message data is lost, damaged, or destroyed as a result of BellSouth error or omission, including but not limited to, the acts or omissions of BellSouth employees, agents and suppliers, and the failures of BellSouth hardware, software and other BellSouth equipment, when BellSouth is performing the billing and/or recording function, and the data cannot be recovered or resupplied within two (2) bill periods, BellSouth shall notify <<customer\_short\_name>> of the estimated amount of <<customer\_short\_name>> unbillable revenue in accordance with Section 5.3. BellSouth shall compensate <<customer\_short\_name>> for this unbillable revenue within three (3) bill periods.



- 5.2.2 When <<customer\_short\_name>> message data is lost, damaged, or destroyed as a result of BellSouth error or omission, including but not limited to, the acts or omissions of BellSouth employees, agents and suppliers, and the failures of BellSouth hardware, software and other BellSouth equipment, when <<customer\_short\_name>> is performing the billing and/or recording function, and the data cannot be recovered or resupplied within two (2) bill periods, BellSouth shall notify <<customer\_short\_name>> of the estimated amount of <<customer\_short\_name>> unbillable revenue in accordance with Section 5.3 of this Attachment. BellSouth shall compensate <<customer\_short\_name>> for the net loss to <<customer\_short\_name>> within three (3) bill periods.

### 5.3 Determination of Losses.

- 5.3.1 **Material Loss.** BellSouth shall review its daily controls to determine if data has been lost. The message threshold (5000 (this is the number of messages on the switch for all carriers including inter and intraLATA as well as Local) messages within the missing data period) used by BellSouth to determine if there has been a material loss of its own messages will also be used to determine if a material loss of <<customer\_short\_name>>'s messages has occurred. A nonmaterial loss will not be reported and any unbillable revenues will not be credited to <<customer\_short\_name>>. When it is known that there has been a material loss, actual message and minute volumes should be reported if possible. Where actual data is not available, a full day shall be estimated for the recording entity as outlined in the Section 5.3.1.1 below. The loss is then determined by subtracting recorded data, if any is available, from the estimated total day's business.
- 5.3.1.1 **Estimated Volumes.** From message and minute volume reports for the entity experiencing the loss, BellSouth shall secure message/minute counts for the corresponding day of the week for eight (8) weeks preceding the week in which the loss occurred. BellSouth shall apply the appropriate Average Revenue Per Message (ARPM) to the estimated message volume to arrive at the estimated lost revenue.
- 5.3.2 **Complete Loss.** Estimated message and minute volumes for each loss consisting of an entire/tape or file lost in transit, lost after receipt, degaussed before processing, received blank or unreadable, etc. shall be reported. Also the loss of one or more boxes of operator tickets shall be estimated and reported if applicable.
- 5.3.3 BellSouth shall notify <<customer\_short\_name>> in advance of the date of monthly billing statement that shall contain such adjustments. BellSouth shall provide sufficient information to allow <<customer\_short\_name>> to analyze the data supporting BellSouth's estimate of revenue due to <<customer\_short\_name>>.

## 6. OPTIONAL DAILY USAGE FILE

- 6.1 Upon written request from <<customer\_short\_name>>, BellSouth will provide the Optional Daily Usage File (ODUF) service to <<customer\_short\_name>> pursuant to the terms and conditions set forth in this Section.
- 6.2 <<customer\_short\_name>> shall furnish all relevant information required by BellSouth for the provision of the ODUF.
- 6.3 The ODUF feed will contain messages that were carried over the BellSouth Network and processed in the BellSouth Billing System, but billed to a <<customer\_short\_name>> customer.
- 6.4 Charges for the ODUF will appear on <<customer\_short\_name>>'s monthly bills for the previous month's usage. The charges are as set forth in Exhibit A to this Attachment. <<customer\_short\_name>> will be billed at the ODUF rates that are in effect at the end of the previous month.
- 6.5 The ODUF feed will contain both rated and unrated messages. All messages will be in the standard Alliance for Telecommunications Industry Solutions (ATIS) EMI record format.
- 6.6 Messages that error in the billing system of <<customer\_short\_name>> will be the responsibility of <<customer\_short\_name>>. If, however, <<customer\_short\_name>> should encounter significant volumes of errored messages that prevent processing by <<customer\_short\_name>> within its systems, BellSouth will work with <<customer\_short\_name>> to determine the source of the errors and the appropriate resolution. Upon request from <<customer\_short\_name>>, BellSouth shall resend errored messages in accordance with SQM B-9.
- 6.7 The following specifications shall apply to the ODUF feed.
- 6.7.1 ODUF Messages to be Transmitted
- 6.7.1.1 The following messages recorded by BellSouth will be transmitted to <<customer\_short\_name>>:
- 6.7.1.1.1 Message recording for per use/per activation type services (examples:  
Three -Way Calling, Verify, Interrupt, Call Return, etc.)
- 6.7.1.1.2 Measured Local
- 6.7.1.1.3 Directory Assistance messages
- 6.7.1.1.4 IntraLATA Toll
- 6.7.1.1.5 WATS and 800 Service

- 6.7.1.1.6 N11
- 6.7.1.1.7 Information Service Provider Messages
- 6.7.1.1.8 Operator Services Messages
- 6.7.1.1.9 Operator Services Message Attempted Calls (Network Element only)
- 6.7.1.1.10 Credit/Cancel Records
- 6.7.1.1.11 Usage for Voice Mail Message Service
- 6.7.1.2 Rated Incollects (messages BellSouth receives from other revenue accounting offices) can also be on ODUF. Rated Incollects will be intermingled with BellSouth recorded rated and unrated usage. Rated Incollects will not be packed separately.
- 6.7.1.3 BellSouth will perform duplicate record checks on records processed to ODUF. Any duplicate messages detected will be deleted and not sent to <<customer\_short\_name>>.
- 6.7.1.4 In the event that <<customer\_short\_name>> detects a duplicate on ODUF they receive from BellSouth, <<customer\_short\_name>> will drop the duplicate message and will not return the duplicate to BellSouth.
- 6.7.2 ODUF Physical File Characteristics
  - 6.7.2.1 ODUF will be distributed to <<customer\_short\_name>> via CONNECT:Direct, CONNECT:Enterprise Client or another mutually agreed medium. The ODUF feed will be a variable block format. The data on the ODUF feed will be in a non-compacted EMI format (175 byte format plus modules). It will be created on a daily basis Monday through Friday except holidays. Details such as dataset name and delivery schedule will be addressed during negotiations of the distribution medium. There will be a maximum of one dataset per workday per OCN.
  - 6.7.2.2 Data circuits (private line or dial-up) will be required between BellSouth and <<customer\_short\_name>> for the purpose of data transmission as set forth in Section 4.10.1 above.
  - 6.7.2.3 If <<customer\_short\_name>> utilizes CONNECT:Enterprise Client for data file transmission, purchase of the CONNECT:Enterprise Client software will be the responsibility of <<customer\_short\_name>>.
- 6.7.3 ODUF Packing Specifications
  - 6.7.3.1 A pack will contain a minimum of one message record or a maximum of 99,999 message records plus a pack header record and a pack trailer record. One

transmission can contain a maximum of ninety-nine (99) packs and a minimum of one (1) pack.

- 6.7.3.2 The OCN, From RAO, and Invoice Number will control the invoice sequencing. The From RAO will be used to identify to <<customer\_short\_name>> which BellSouth RAO that is sending the message. BellSouth and <<customer\_short\_name>> will use the invoice sequencing to control data exchange. BellSouth will be notified of sequence failures identified by <<customer\_short\_name>> and resend the data as quickly as technically possible.
- 6.7.3.3 The data will be packed using ATIS EMI records.
- 6.7.4 ODUF Pack Rejection
- 6.7.4.1 <<customer\_short\_name>> will notify BellSouth within one business day of rejected packs (via the mutually agreed medium). Packs could be rejected because of pack sequencing discrepancies or a critical edit failure on the Pack Header or Pack Trailer records (i.e. out-of-balance condition on grand totals, invalid data populated). Standard ATIS EMI error codes will be used. <<customer\_short\_name>> will not be required to return the actual rejected data to BellSouth. Rejected packs will be corrected and retransmitted to <<customer\_short\_name>> by BellSouth.
- 6.7.5 ODUF Control Data
- 6.7.5.1 <<customer\_short\_name>> will send one confirmation record per pack that is received from BellSouth. This confirmation record will indicate <<customer\_short\_name>>'s receipt of the pack and acceptance or rejection of the pack. Pack Status Code(s) will be populated using standard ATIS EMI error codes for packs that were rejected by <<customer\_short\_name>> for reasons stated in the above Section.
- 6.7.6 ODUF Testing
- 6.7.6.1 Upon request from <<customer\_short\_name>>, BellSouth shall send ODUF test files to <<customer\_short\_name>>. The Parties agree to review and discuss the ODUF content and/or format. For testing of usage results, BellSouth shall request that <<customer\_short\_name>> set up a production (live) file. The live test may consist of <<customer\_short\_name>>'s employees making test calls for the types of services <<customer\_short\_name>> requests on ODUF. These test calls are logged by <<customer\_short\_name>>, and the logs are provided to BellSouth. These logs will be used to verify the files. Testing will be completed within 30 calendar days from the date on which the initial test file was sent.

## 7. ACCESS DAILY USAGE FILE

- 7.1 Upon written request from <<customer\_short\_name>>, BellSouth will provide the Access Daily Usage File (ADUF) service to <<customer\_short\_name>> pursuant to the terms and conditions set forth in this Section.
- 7.2 <<customer\_short\_name>> shall furnish all relevant information required by BellSouth for the provision of ADUF.
- 7.3 ADUF will contain access messages associated with a port that <<customer\_short\_name>> has purchased from BellSouth
- 7.4 Charges for ADUF will appear on <<customer\_short\_name>>'s monthly bills for the previous month's usage. The charges are as set forth in Exhibit A to this Attachment. <<customer\_short\_name>> will be billed at the ADUF rates that are in effect at the end of the previous month.
- 7.5 Messages that error in the billing system of <<customer\_short\_name>> will be the responsibility of <<customer\_short\_name>>. If, however, <<customer\_short\_name>> should encounter significant volumes of errored messages that prevent processing by <<customer\_short\_name>> within its systems, BellSouth will work with <<customer\_short\_name>> to determine the source of the errors and the appropriate resolution. Upon request from <<customer\_short\_name>>, BellSouth shall resend errored messages in accordance with SQM B-9.
- 7.6 ADUF Messages To Be Transmitted
- 7.6.1 The following messages recorded by BellSouth will be transmitted to <<customer\_short\_name>>:
- 7.6.1.1 Recorded originating and terminating interstate and intrastate access records associated with a port.
- 7.6.1.2 Recorded terminating access records for undetermined jurisdiction access records associated with a port.
- 7.6.2 BellSouth will perform duplicate record checks on records processed to ADUF. Any duplicate messages detected will be dropped and not sent to <<customer\_short\_name>>.
- 7.6.3 In the event that <<customer\_short\_name>> detects a duplicate on ADUF they receive from BellSouth, <<customer\_short\_name>> will drop the duplicate message and will not return the duplicate to BellSouth.
- 7.6.4 ADUF Physical File Characteristics
- 7.6.4.1 ADUF will be distributed to <<customer\_short\_name>> via CONNECT:Direct, CONNECT:Enterprise Client or another mutually agreed medium. The ADUF feed will be a fixed block format. The data on the ADUF feed will be in a non-

compacted EMI format (210 byte). It will be created on a daily basis Monday through Friday except holidays. Details such as dataset name and delivery schedule will be addressed during negotiations of the distribution medium. There will be a maximum of one dataset per workday per OCN.

- 7.6.4.2 Data circuits (private line or dial-up) will be required between BellSouth and <<customer\_short\_name>> for the purpose of data transmission as set forth in Section 4.10.1 above.
- 7.6.4.3 If <<customer\_short\_name>> utilizes CONNECT:Enterprise Client for data file transmission, purchase of the CONNECT:Enterprise Client software will be the responsibility of <<customer\_short\_name>>.
- 7.6.5 ADUF Packing Specifications
- 7.6.5.1 A pack will contain a minimum of one message record or a maximum of 99,999 message records plus a pack header record and a pack trailer record. One transmission can contain a maximum of ninety-nine (99) packs and a minimum of one (1) pack.
- 7.6.5.2 The OCN, From RAO, and Invoice Number will control the invoice sequencing. The From RAO will be used to identify to <<customer\_short\_name>> which BellSouth RAO is sending the message. BellSouth and <<customer\_short\_name>> will use the invoice sequencing to control data exchange. BellSouth will be notified of sequence failures identified by <<customer\_short\_name>> and resend the data.
- 7.6.5.3 The data will be packed using ATIS EMI records. as quickly as technically possible
- 7.6.6 ADUF Pack Rejection
- 7.6.6.1 <<customer\_short\_name>> will notify BellSouth within one business day of rejected packs (via the mutually agreed medium). Packs could be rejected because of pack sequencing discrepancies or a critical edit failure on the Pack Header or Pack Trailer records (i.e. out-of-balance condition on grand totals, invalid data populated). Standard ATIS EMI error codes will be used. <<customer\_short\_name>> will not be required to return the actual rejected data to BellSouth. Rejected packs will be corrected and retransmitted to <<customer\_short\_name>> by BellSouth.
- 7.6.7 ADUF Control Data
- 7.6.7.1 <<customer\_short\_name>> will send one confirmation record per pack that is received from BellSouth. This confirmation record will indicate <<customer\_short\_name>>'s receipt of the pack and acceptance or rejection of the pack. Pack Status Code(s) will be populated using standard ATIS EMI error

codes for packs that were rejected by <<customer\_short\_name>> for reasons stated in the above Section.

#### 7.6.8 ADUF Testing

7.6.8.1 Upon request from <<customer\_short\_name>>, BellSouth shall send a test file of generic data to <<customer\_short\_name>> via Connect:Direct or Text File via E-Mail. The Parties agree to review and discuss the test file's content and/or format.

### **8. ENHANCED OPTIONAL DAILY USAGE FILE**

8.1 Upon written request from <<customer\_short\_name>>, BellSouth will provide the Enhanced Optional Daily Usage File (EODUF) service to <<customer\_short\_name>> pursuant to the terms and conditions set forth in this Section. EODUF will only be sent to existing ODUF subscribers who request the EODUF option.

8.2 <<customer\_short\_name>> shall furnish all relevant information required by BellSouth for the provision of the EODUF.

8.3 The EODUF will provide usage data for local calls originating from resold Flat Rate Business and Residential Lines.

8.4 Charges for delivery of the EODUF will appear on <<customer\_short\_name>>'s monthly bills for the previous month's usage. The charges are as set forth in Exhibit A to this Attachment. <<customer\_short\_name>> will be billed at the EODUF rates that are in effect at the end of the previous month.

8.5 All messages will be in the standard Alliance for Telecommunications Industry Solutions (ATIS) EMI record format.

8.6 Messages that error in the billing system of <<customer\_short\_name>> will be the responsibility of <<customer\_short\_name>>. If, however, <<customer\_short\_name>> should encounter significant volumes of errored messages that prevent processing by <<customer\_short\_name>> within its systems, BellSouth will work with <<customer\_short\_name>> to determine the source of the errors and the appropriate resolution. Upon request from <<customer\_short\_name>>, BellSouth shall resend errored messages in accordance with SQM B-9.

8.7 The following specifications shall apply to the EODUF feed.

#### 8.7.1 Usage To Be Transmitted

8.7.1.1 The following messages recorded by BellSouth will be transmitted to <<customer\_short\_name>>:

- 8.7.1.1.1 Customer usage data for flat rated local call originating from <<customer\_short\_name>>'s End User lines (1FB or 1FR). The EODUF record for flat rate messages will include:
- 8.7.1.1.1.1 Date of Call
  - 8.7.1.1.1.2 From Number
  - 8.7.1.1.1.3 To Number
  - 8.7.1.1.1.4 Connect Time
  - 8.7.1.1.1.5 Conversation Time
  - 8.7.1.1.1.6 Method of Recording
  - 8.7.1.1.1.7 From RAO
  - 8.7.1.1.1.8 Rate Class
  - 8.7.1.1.1.9 Message Type
  - 8.7.1.1.1.10 Billing Indicators
  - 8.7.1.1.1.11 Bill to Number
- 8.7.1.2 BellSouth will perform duplicate record checks on EODUF records processed to ODUF. Any duplicate messages detected will be deleted and not sent to <<customer\_short\_name>>.
- 8.7.1.3 In the event that <<customer\_short\_name>> detects a duplicate on EODUF they receive from BellSouth, <<customer\_short\_name>> will drop the duplicate message (<<customer\_short\_name>> will not return the duplicate to BellSouth).
- 8.7.2 Physical File Characteristics
- 8.7.2.1 The EODUF feed will be distributed to <<customer\_short\_name>> over their existing ODUF feed. The EODUF messages will be intermingled among <<customer\_short\_name>>'s ODUF messages. The EODUF will be a variable block format (2476) with an LRECL of 2472. The data on the EODUF will be in a non-compacted EMI format (175 byte format plus modules). It will be created on a daily basis (Monday through Friday except holidays).
  - 8.7.2.2 Data circuits (private line or dial-up) may be required between BellSouth and <<customer\_short\_name>> for the purpose of data transmission. Where a dedicated line is required, <<customer\_short\_name>> will be responsible for ordering the circuit, overseeing its installation and coordinating the installation with BellSouth. <<customer\_short\_name>> will also be responsible for any



charges associated with this line. CSU/DSU equipment required on the BellSouth end to attach the line to the mainframe computer and to transmit successfully ongoing will be the responsibility of <<customer\_short\_name>>. Where a dial-up facility will be required, dial circuits will be installed in the BellSouth data center by BellSouth and the associated charges assessed to <<customer\_short\_name>>. Additionally, all message toll charges associated with the use of the dial circuit by <<customer\_short\_name>> will be the responsibility of <<customer\_short\_name>>. Associated equipment on the BellSouth end, including a modem, will be the responsibility of BellSouth. All equipment, including modems and software, that is required on <<customer\_short\_name>>'s end for the purpose of data transmission will be the responsibility of <<customer\_short\_name>>.

### 8.7.3 Packing Specifications

8.7.3.1 A pack will contain a minimum of one message record or a maximum of 99,999 message records plus a pack header record and a pack trailer record. One transmission can contain a maximum of 99 packs and a minimum of one pack.

8.7.3.2 The Operating Company Number (OCN), From Revenue Accounting Office (RAO), and Invoice Number will control the invoice sequencing. The From RAO will be used to identify to <<customer\_short\_name>> which BellSouth RAO is sending the message. BellSouth and <<customer\_short\_name>> will use the invoice sequencing to control data exchange. BellSouth will be notified of sequence failures identified by <<customer\_short\_name>> and resend the data as quickly as technically possible.

8.7.3.3 The data will be packed using ATIS EMI records.

ODUF/ADUF/CMDS - Kentucky														Attachment: 7		Exhibit: A								
CATEGORY	RATE ELEMENTS	Interim	Zone	BCS	USOC	RATES (\$)	Svc Order Submitted Elec per LSR	Svc Order Submitted Manually per LSR	Incremental Charge - Manual Svc Order vs. Electronic-1st	Incremental Charge - Manual Svc Order vs. Electronic-Add'l	Incremental Charge - Manual Svc Order vs. Electronic-Disc 1st	Incremental Charge - Manual Svc Order vs. Electronic-Disc Add'l	OSS Rates (\$)											
													Rec	Nonrecurring		Nonrecurring Disconnect		SOMEc	SOMAN	SOMAN	SOMAN	SOMAN	SOMAN	
														First	Add'l	First	Add'l							
<b>ODUF/ADUF/CMDS</b>																								
	<b>ACCESS DAILY USAGE FILE (ADUF)</b>																							
	ADUF: Message Processing, per message					0.001857																		
	ADUF: Data Transmission (CONNECT:DIRECT), per message					0.00012447																		
	<b>OPTIONAL DAILY USAGE FILE (ODUF)</b>																							
	ODUF: Recording, per message					0.0000136																		
	ODUF: Message Processing, per message					0.002506																		
	ODUF: Message Processing, per Magnetic Tape provisioned					35.90																		
	ODUF: Data Transmission (CONNECT:DIRECT), per message					0.00010372																		
	<b>CENTRALIZED MESSAGE DISTRIBUTION SERVICE (CMDS)</b>																							
	CMDS: Message Processing, per message					0.004																		
	CMDS: Data Transmission (CONNECT:DIRECT), per message					0.001																		
Notes: If no rate is identified in the contract, the rate for the specific service or function will be as set forth in applicable BellSouth tariff or as negotiated by the Parties upon request by either Party.																								

**Attachment 8**

**Rights-of-Way, Conduits and Pole Attachments**

## **Rights-of-Way, Conduits and Pole Attachments**

BellSouth will provide nondiscriminatory access to any pole, duct, conduit, or right-of-way owned or controlled by BellSouth pursuant to 47 U.S.C. § 224, as amended by the Act, pursuant to terms and conditions of a license agreement subsequently negotiated with BellSouth's Competitive Structure Provisioning Center.

**Attachment 9**

**Performance Measurements and Associated Remedies**

## **PERFORMANCE MEASUREMENTS AND ASSOCIATED REMEDIES**

Upon a particular Commission's issuance of an Order pertaining to Performance Measurements and any associated remedies or enforcement mechanisms (including SEEMs measures and payments) in a proceeding applicable to all CLECs generally, BellSouth shall implement in that state such Performance Measurements and any associated remedies or enforcement mechanisms (including SEEMs measures and payments) as of the date specified by the Commission. Performance Measurements and any associated remedies or enforcement mechanisms (including SEEMs measures and payments) that have been ordered in a particular state can currently be accessed via the internet at <https://pmap.bellsouth.com>. The attached Service Quality Measurements (SQM) plan adopted by the Florida Commission on February 14, 2002, as it presently exists and as it may be modified in the future, is being included as the performance measurements and associated remedies or enforcement mechanisms (including SEEMs measures and payments) currently in place for the state of Tennessee. At such time that the TRA issues a subsequent Order pertaining to Performance Measurements and any associated remedies or enforcement mechanisms (including SEEMs measures and payments), such Performance Measurements and any associated remedies or enforcement mechanisms (including SEEMs measures and payments) shall supersede the SQM contained in this Agreement. Nothing in this Attachment 9 shall supercede a Party's right to other remedies or legal recourse available under other provisions of this Agreement, the Act and Applicable Law; provided, however, that the payment of any associated remedies or enforcement mechanisms to each CLEC shall be credited against any liability associated with or related to BellSouth's service performance and shall not be considered an admission against interest or an admission of culpability or liability in any legal, regulatory or other proceeding, nor constitute evidence that BellSouth failed to comply with or has violated any state or federal law or regulation.

## Attachment 10

### BellSouth Disaster Recovery Plan

#### CONTENTS



#### PAGE

1.0	Purpose	2
2.0	Single Point of Contact	2
3.0	Identifying the Problem	2
3.1	Site Control	3
3.2	Environmental Concerns	4
4.0	The Emergency Control Center (ECC)	4
5.0	Recovery Procedures	5
5.1	CLEC Outage	5
5.2	BellSouth Outage	5
5.2.1	Loss of Central Office	6
5.2.2	Loss of a Central Office with Serving Wire Center Functions	6
5.2.3	Loss of a Central Office with Tandem Functions	6
5.2.4	Loss of a Facility Hub	7
5.3	Combined Outage (CLEC and BellSouth Equipment)	7
6.0	T1 Identification Procedures	7
7.0	Acronyms	8
8.0	Hurricane Information	8
9.0	BST Disaster Management Plan	8

## **1.0 PURPOSE**

In the unlikely event of a disaster occurring that affects BellSouth's long-term ability to deliver traffic to a Competitive Local Exchange Carrier (CLEC), general procedures have been developed by BellSouth to hasten the recovery process in accordance with the Telecommunications Service Priority (TSP) Program established by the Federal Communications Commission to identify and prioritize telecommunication services that support national security or emergency preparedness (NS/EP) missions. Since each location is different and could be affected by an assortment of potential problems, a detailed recovery plan is impractical. However, in the process of reviewing recovery activities for specific locations, some basic procedures emerge that appear to be common in most cases.

These general procedures should apply to any disaster that affects the delivery of traffic for an extended time period. Each CLEC will be given the same consideration during an outage, and service will be restored as quickly as possible.

This document will cover the basic recovery procedures that would apply to every CLEC.

## **2.0 SINGLE POINT OF CONTACT**

When a problem is experienced, regardless of the severity, the BellSouth Network Management Center (NMC) will observe traffic anomalies and begin monitoring the situation. Controls will be appropriately applied to insure the operability of BellSouth's network; and, in the event that a switch or facility node is lost, the NMC will attempt to circumvent the failure using available reroutes.

BellSouth's NMC will remain in control of the restoration efforts until the problem has been identified as being a long-term outage. At that time, the NMC will contact BellSouth's Emergency Control Center (ECC) and relinquish control of the recovery efforts. Even though the ECC may take charge of the situation, the NMC will continue to monitor the circumstances and restore traffic as soon as damaged network elements are revitalized.

The telephone number for the BellSouth Network Management Center in Atlanta, as published in Telcordia's National Network Management Directory, is 404-321-2516. The telephone number for <<customer\_short\_name>>'s Local Switch Control Center is [INSERT NUMBER].

## **3.0 IDENTIFYING THE PROBLEM**

During the early stages of problem detection, the NMC will be able to tell which CLECs are affected by the catastrophe. Further analysis and/or first hand observation will determine if the disaster has affected CLEC equipment only, BellSouth equipment only or a combination. The initial restoration activity will be largely determined by the equipment that is affected.

Once the nature of the disaster is determined and after verifying the cause of the problem, the NMC will initiate reroutes and/or transfers that are jointly agreed upon by the affected CLECs' Network Management Center and the BellSouth NMC. The type and percentage of controls used will depend upon available network capacity. Controls necessary to stabilize the situation will be invoked and the NMC will attempt to re-establish as much traffic as possible.



For long-term outages, recovery efforts will be coordinated by the Emergency Control Center (ECC). Traffic controls will continue to be applied by the NMC until facilities are re-established. As equipment is made available for service, the ECC will instruct the NMC to begin removing the controls and allow traffic to resume.

### **3.1 SITE CONTROL**

In the total loss of building use scenario, what likely exists will be a smoking pile of rubble. This rubble will contain many components that could be dangerous. It could also contain any personnel on the premises at the time of the disaster. For these reasons, the local fire marshal with the assistance of the police will control the site until the building is no longer a threat to surrounding properties and the companies have secured the site from the general public.

During this time, the majority owner of the building should be arranging for a demolition contractor to mobilize to the site with the primary objective of reaching the cable entrance facility for a damage assessment. The results of this assessment would then dictate immediate plans for restoration, both short term and permanent.

In a less catastrophic event, i.e., the building is still standing and the cable entrance facility is usable, the situation is more complex. The site will initially be controlled by local authorities until the threat to adjacent property has diminished. Once the site is returned to the control of the companies, the following events should occur.

An initial assessment of the main building infrastructure systems (mechanical, electrical, fire and life safety, elevators, and others) will establish building needs. Once these needs are determined, the majority owner should lead the building restoration efforts. There may be situations where the site will not be totally restored within the confines of the building. The companies must individually determine their needs and jointly assess the cost of permanent restoration to determine the overall plan of action.

Multiple restoration trailers from each company will result in the need for designated space and installation order. This layout and control is required to maximize the amount of restoration equipment that can be placed at the site, and the priority of placements.

Care must be taken in this planning to ensure other restoration efforts have logistical access to the building. Major components of telephone and building equipment will need to be removed and replaced. A priority for this equipment must also be jointly established to facilitate overall site restoration. (Example: If the AC switchgear has sustained damage, this would be of the highest priority in order to regain power, lighting, and HVAC throughout the building.)

If the site will not accommodate the required restoration equipment, the companies would then need to quickly arrange with local authorities for street closures, rights of way or other possible options available.

### **3.2 ENVIRONMENTAL CONCERNS**

In the worse case scenario, many environmental concerns must be addressed. Along with the police and fire marshal, the state environmental protection department will be on site to monitor the situation.

Items to be concerned with in a large central office building could include:

1. Emergency engine fuel supply. Damage to the standby equipment and the fuel handling equipment could have created "spill" conditions that have to be handled within state and federal regulations.
2. Asbestos-containing materials that may be spread throughout the wreckage. Asbestos could be in many components of building, electrical, mechanical, outside plant distribution, and telephone systems.
3. Lead and acid. These materials could be present in potentially large quantities depending upon the extent of damage to the power room.
4. Mercury and other regulated compounds resident in telephone equipment.
5. Other compounds produced by the fire or heat.

Once a total loss event occurs at a large site, local authorities will control immediate clean up (water placed on the wreckage by the fire department) and site access.

At some point, the companies will become involved with local authorities in the overall planning associated with site clean up and restoration. Depending on the clean up approach taken, delays in the restoration of several hours to several days may occur.

In a less severe disaster, items listed above are more defined and can be addressed individually depending on the damage.

In each case, the majority owner should coordinate building and environmental restoration as well as maintain proper planning and site control.

### **4.0 THE EMERGENCY CONTROL CENTER (ECC)**

The ECC is located in the Midtown 1 Building in Atlanta, Georgia. During an emergency, the ECC staff will convene a group of pre-selected experts to inventory the damage and initiate corrective actions. These experts have regional access to BellSouth's personnel and equipment and will assume control of the restoration activity anywhere in the nine-state area.

In the past, the ECC has been involved with restoration activities resulting from hurricanes, ice storms and floods. They have demonstrated their capabilities during these calamities as well as during outages caused by human error or equipment failures. This group has an excellent record of restoring service as quickly as possible.

During a major disaster, the ECC may move emergency equipment to the affected location, direct recovery efforts of local personnel and coordinate service restoration activities with the CLECs. The ECC will attempt to restore service as quickly as possible using whatever means is available, leaving permanent solutions, such as the replacement of damaged buildings or equipment, for local personnel to administer.

Part of the ECC's responsibility, after temporary equipment is in place, is to support the NMC efforts to return service to the CLECs. Once service has been restored, the ECC will return control of the network to normal operational organizations. Any long-term changes required after service is restored will be made in an orderly fashion and will be conducted as normal activity.

## **5.0 RECOVERY PROCEDURES**

The nature and severity of any disaster will influence the recovery procedures. One crucial factor in determining how BellSouth will proceed with restoration is whether or not BellSouth's equipment is incapacitated. Regardless of whose equipment is out of service, BellSouth will move as quickly as possible to aid with service recovery; however, the approach that will be taken may differ depending upon the location of the problem.

### **5.1 CLEC OUTAGE**

For a problem limited to one CLEC (or a building with multiple CLECs), BellSouth has several options available for restoring service quickly. For those CLECs that have agreements with other CLECs, BellSouth can immediately start directing traffic to a provisional CLEC for completion. This alternative is dependent upon BellSouth having concurrence from the affected CLECs.

Whether or not the affected CLECs have requested a traffic transfer to another CLEC will not impact BellSouth's resolve to re-establish traffic to the original destination as quickly as possible.

### **5.2 BELLSOUTH OUTAGE**

Because BellSouth's equipment has varying degrees of impact on the service provided to the CLECs, restoring service from damaged BellSouth equipment is different. The outage will probably impact a number of Carriers simultaneously. However, the ECC will be able to initiate immediate actions to correct the problem.

A disaster involving any of BellSouth's equipment locations could impact the CLECs, some more than others. A disaster at a Central Office (CO) would only impact the delivery of traffic to and from that one location, but the incident could affect many Carriers. If the Central Office is a Serving Wire Center (SWC), then traffic from the entire area to those Carriers served from that switch would also be impacted. If the switch functions as an Access Tandem, or there is a tandem in the building, traffic from every CO to every CLEC could be interrupted. A disaster that destroys a facility hub could disrupt various traffic flows, even though the switching equipment may be unaffected.

The NMC would be the first group to observe a problem involving BellSouth's equipment. Shortly after a disaster, the NMC will begin applying controls and finding re-routes for the completion of as much traffic as possible. These reroutes may involve delivering traffic to alternate Carriers upon receiving approval from the CLECs involved. In some cases, changes in translations will be required. If the outage is caused by the destruction of equipment, then the ECC will assume control of the restoration.

### **5.2.1 Loss of a Central Office**

When BellSouth loses a Central Office, the ECC will

- a) Place specialists and emergency equipment on notice;
- b) Inventory the damage to determine what equipment and/or functions are lost;
- c) Move containerized emergency equipment and facility equipment to the stricken area, if necessary;
- d) Begin reconnecting service on a parity basis for Hospitals, Police and other emergency agencies or End Users served by BellSouth or CLEC in accordance with the TSP priority restoration coding scheme entered in the BellSouth Maintenance database immediately prior to the emergency;
- e) Begin restoring service, on a parity basis, to other End Users served by CLECs or BellSouth.

### **5.2.2 Loss of a Central Office with Serving Wire Center Functions**

The loss of a Central Office that also serves as a Serving Wire Center (SWC) will be restored as described in Section 5.2.1.

### **5.2.3 Loss of a Central Office with Tandem Functions**

When BellSouth loses a Central Office building that serves as an Access Tandem and as a SWC, the ECC will

- a) Place specialists and emergency equipment on notice;
- b) Inventory the damage to determine what equipment and/or functions are lost;
- c) Move containerized emergency equipment and facility equipment to the stricken area, if necessary;
- d) Begin reconnecting service on a parity basis for Hospitals, Police and other emergency agencies or End Users served by BellSouth or CLEC in accordance with the TSP priority restoration coding scheme entered in the BellSouth Maintenance database immediately prior to the emergency;

- e) Re-direct as much traffic as possible to the alternate access tandem (if available) for delivery to those CLECs utilizing a different location as a SWC;
- f) Begin aggregating traffic to a location near the damaged building. From this location, begin re-establishing trunk groups to the CLECs for the delivery of traffic normally found on the direct trunk groups (This aggregation point may be the alternate access tandem location or another CO on a primary facility route.);
- g) Begin restoring service, on a parity basis, to other End Users served by CLECs or BellSouth.

#### **5.2.4 Loss of a Facility Hub**

In the event that BellSouth loses a facility hub, the recovery process is much the same as above. Once the NMC has observed the problem and administered the appropriate controls, the ECC will assume authority for the repairs. The recovery effort will include

- a) Placing specialists and emergency equipment on notice;
- b) Inventorying the damage to determine what equipment and/or functions are lost;
- c) Moving containerized emergency equipment to the stricken area, if necessary;
- d) Reconnecting service on a parity basis for Hospitals, Police and other emergency agencies or End Users served by BellSouth or CLEC in accordance with the TSP priority restoration coding scheme entered in the BellSouth Maintenance database immediately prior to the emergency; and
- e) If necessary, BellSouth will aggregate the traffic at another location and build temporary facilities. This alternative would be viable for a location that is destroyed and building repairs are required.
- f) Begin restoring service, on a parity basis, to other End Users served by CLECs or BellSouth.

### **5.3 COMBINED OUTAGE (CLEC AND BELLSOUTH EQUIPMENT)**

In some instances, a disaster may impact BellSouth equipment as well as the CLEC equipment. This situation will be handled in much the same way as described in Section 5.2.3. Since BellSouth and the CLECs will be utilizing temporary equipment, close coordination will be required.

### **6.0 T1 IDENTIFICATION PROCEDURES**

During the restoration of service after a disaster, BellSouth may be forced to aggregate traffic for delivery to a CLEC. During this process, T1 traffic may be consolidated onto DS3s and may become unidentifiable to the Carrier. Because resources will be limited, BellSouth may be forced to "package" this traffic entirely differently than normally received by the CLECs. Therefore, a method for identifying the T1 traffic on the DS3s and providing the information to the Carriers is required. If information to facilitate billing among Carriers needs to be established, the Parties shall negotiate in good faith a resolution of such identification, information and billing issues and

may use traffic figures averaged over the most recent three (3) month period as a proxy taking into account known or expected deviations during the recovery period.

## **7.0 ACRONYMS**

CLEC	-	Competitive Local Exchange Carrier
CO	-	Central Office (BellSouth)
DS3	-	Facility that carries 28 T1s (672 circuits)
ECC	-	Emergency Control Center (BellSouth)
NMC	-	Network Management Center
SWC	-	Serving Wire Center (BellSouth switch)
T1	-	Facility that carries 24 circuits
TSP	-	Telecommunications Service Priority

## **8.0 Hurricane Information**

During a hurricane, BellSouth will make every effort to keep CLECs updated on the status of our network. Information centers will be set up by BellSouth. These centers are not intended to be used for escalations, but rather to keep the CLEC informed of network related issues, area damages and dispatch conditions, etc.

Hurricane-related information will be regularly updated and can also be found on line at [http://www.interconnection.bellsouth.com/network/disaster/dis\\_resp.htm](http://www.interconnection.bellsouth.com/network/disaster/dis_resp.htm). Information concerning Mechanized Disaster Reports can also be found at this website by clicking on CURRENT MDR REPORTS or by going directly to <http://www.interconnection.bellsouth.com/network/disaster/mdrs.htm>.

## **9.0 BST Disaster Management Plan**

BellSouth maintenance centers have geographical and redundant communication capabilities. In the event of a disaster removing any maintenance center from service another geographical center would assume maintenance responsibilities. The contact numbers will not change and the transfer will be transparent to the CLEC.

**Attachment 11**

**Bona Fide Request and New Business Request Process**

## **BONA FIDE REQUEST AND NEW BUSINESS REQUEST PROCESS**

### **1.0 BONA FIDE REQUEST**

1.1 The Parties agree that <<customer\_short\_name>> is entitled to order any network element, interconnection option, or service option required to be made available by FCC or Commission requirements pursuant to the Act. A Bona Fide Request (BFR) is to be used when <<customer\_short\_name>> makes a request of BellSouth to provide a new or modified network element, interconnection option or other service option pursuant to the Act that was not previously provided for in this Agreement.

1.2 A BFR shall be submitted in writing by <<customer\_short\_name>> and shall specifically identify the requested service date, technical requirements, space requirements and/or such other specifications that clearly define the request such that BellSouth has sufficient information to analyze and prepare a response. Such a request shall also include <<customer\_short\_name>>'s designation of the request as being pursuant to the Telecommunications Act of 1996 (*i.e.*, a BFR). The request shall be sent to <<customer\_short\_name>>'s designated BellSouth sales contact or Local Contract Manager.

1.3 Within two (2) business days of receipt of a BFR, BellSouth shall acknowledge in writing its receipt and identify a single point of contact responsible for responding to the BFR and shall request any additional information needed to process the request to the extent known at that time. Notwithstanding the foregoing, BellSouth may reasonably request additional information from <<customer\_short\_name>> at any time during the processing of the BFR.

1.4 Within thirty (30) business days of BellSouth's receipt of the BFR, if preliminary analysis of the requested BFR is not of such complexity that it will cause BellSouth to expend extraordinary resources to evaluate the BFR, BellSouth shall respond to <<customer\_short\_name>> by providing a preliminary analysis of the new or modified network element or interconnection option not ordered by the FCC or Commission that is the subject of the BFR. The preliminary analysis shall either confirm that BellSouth will offer access to the new or modified network element, interconnection option or service option or confirm that BellSouth will not offer the new or modified network element, interconnection option or service option.

1.5 [Parties Disagree]



[<<customer\_short\_name>> Version] For any new or modified network element, interconnection option or service option not ordered by the FCC or Commission, if the preliminary analysis states that BellSouth will offer the new or modified network element, interconnection option or service option, the preliminary analysis will include an estimate of the **nonrecurring and recurring rates of** the network element, interconnection option or service option and the date the request can be met. If the preliminary analysis states that BellSouth will not offer the new or modified network element, interconnection option or service option, BellSouth will provide an explanation of why the request is not technically feasible, does not qualify as a BFR for the new or modified network element, interconnection option or service option, should actually be submitted as a NBR or is otherwise not required to be provided under the Act. If BellSouth cannot provide the network element, interconnection option or service option by the requested date, BellSouth shall provide an alternative proposed date together with a detailed explanation as to why BellSouth is not able to meet <<customer\_short\_name>>'s requested date.

[BellSouth Version] For any new or modified network element, interconnection option or service option not ordered by the FCC or Commission, if the preliminary analysis states that BellSouth will offer the new or modified network element, interconnection option or service option, the preliminary analysis will include an estimate of the **costs of utilizing existing resources, both personnel and systems, in the development including, but not limited to, request parameters analysis, determination of impacted BellSouth departments, determination of required resources, project management resources, etc. (Development Rate) including a general breakdown of such costs associated with** the network element, interconnection option or service option and the date the request can be met. If the preliminary analysis states that BellSouth will not offer the new or modified network element, interconnection option or service option, BellSouth will provide an explanation of why the request is not technically feasible, does not qualify as a BFR for the new or modified network element, interconnection option or service option, should actually be submitted as a NBR or is otherwise not required to be provided under the Act. If BellSouth cannot provide the network element, interconnection option or service option by the requested date, BellSouth shall provide an alternative proposed date together with a detailed explanation as to why BellSouth is not able to meet <<customer\_short\_name>>'s requested date.

- 1.6 For any new or modified network element, interconnection option or service option not ordered by the FCC or Commission, if BellSouth determines that the preliminary analysis of the requested BFR is of such complexity that it will cause BellSouth to expend extraordinary resources to evaluate the BFR, BellSouth shall notify <<customer\_short\_name>>

within ten (10) business days of BellSouth's receipt of BFR that a fee will be required prior to the preliminary evaluation of the BFR. Such fee shall be limited to BellSouth's extraordinary expenses directly related to the complex request that require the allocation and engagement of additional resources above the existing allocated resources used on BFR/NBR cost development which include, but are not limited to, expenditure of funds to develop feasibility studies, specific resources that are required to determine request requirements (such as operation support system analysts, technical managers, software developers), software impact analysis by specific software developers; software architecture development, hardware impact analysis by specific system analysts, etc. and the request for such fee shall be accompanied with a general breakdown of such costs. If <<customer\_short\_name>> accepts the complex request evaluation fee proposed by BellSouth, <<customer\_short\_name>> shall submit such fee within thirty (30) business days of BellSouth's notice that a complex request evaluation fee is required. Within thirty (30) business days of BellSouth's receipt of the complex request evaluation fee, BellSouth shall respond to <<customer\_short\_name>> by providing a preliminary analysis, consistent with Section 1.4 of this Attachment 11.

- 1.7 <<customer\_short\_name>> may cancel a BFR at any time. If <<customer\_short\_name>> cancels the request within ten (10) business days after submitting the BFR request, no charges will be incurred. If <<customer\_short\_name>> cancels the BFR within thirty (30) business days after receipt of BellSouth's preliminary analysis, BellSouth shall be entitled to keep any complex request evaluation fee submitted in accordance with Section 1.6 above, minus those costs included in the fee that have not been incurred as of the date of cancellation.
- 1.8 <<customer\_short\_name>> will have thirty (30) business days from receipt of preliminary analysis to accept the preliminary analysis or cancel the BFR. If <<customer\_short\_name>> fails to respond within this thirty (30) business day period, the BFR will be deemed cancelled.
- 1.8.1 [Parties Disagree]
- [<<customer\_short\_name>>] Acceptance of the preliminary analysis must be in writing and accompanied by the estimated **nonrecurring rate** for the new or modified network element, interconnection option or service option quoted in the preliminary analysis.
- [BellSouth Version] Acceptance of the preliminary analysis must be in writing and accompanied by the estimated **Development Rate** for the new or modified network element, interconnection option or service option quoted in the preliminary analysis.

1.9

[Parties Disagree]

[<<customer\_short\_name>> Version] Notwithstanding any other provision of this Agreement, BellSouth shall propose a firm price quote, including the firm nonrecurring rate and the firm recurring rate, and a detailed implementation plan within ten (10) business days of receipt of <<customer\_short\_name>>'s accurate BFR application for a network element, interconnection option or service option that is operational at the time of the request; thirty (30) business days of receipt of <<customer\_short\_name>>'s accurate BFR application for a new or modified network element, interconnection option or service option ordered by the FCC or Commission; and within sixty (60) business days of receipt of <<customer\_short\_name>>'s accurate BFR application for a new or modified network element, interconnection option or service option not ordered by the FCC or Commission or not operational at the time of the request. Such firm price quote shall not exceed the estimate provided with the preliminary analysis by more than 25%.

[BellSouth Version] Notwithstanding any other provision of this Agreement, BellSouth shall propose a firm price quote, including **the firm Development Rate**, the firm nonrecurring rate and the firm recurring rate, and a detailed implementation plan within ten (10) business days of receipt of <<customer\_short\_name>>'s accurate BFR application for a network element, interconnection option or service option that is operational at the time of the request; thirty (30) business days of receipt of <<customer\_short\_name>>'s accurate BFR application for a new or modified network element, interconnection option or service option ordered by the FCC or Commission; and within sixty (60) business days of receipt of <<customer\_short\_name>>'s accurate BFR application for a new or modified network element, interconnection option or service option not ordered by the FCC or Commission or not operational at the time of the request. The firm nonrecurring rate will not include any of the Development Rate or the complex request evaluation fee, if required, in the calculation of this rate. Such firm price quote shall not exceed the estimate provided with the preliminary analysis by more than 25%.

1.10

[Parties Disagree]

[<<customer\_short\_name>> Version] <<customer\_short\_name>> shall have thirty (30) business days from receipt of the firm price quote to accept or deny the firm price quote and submit any additional nonrecurring rate quoted in the firm price quote. If the firm price quote is less than the preliminary analysis' estimated nonrecurring rate for the new or modified network element, interconnection option or service option not ordered by the FCC or Commission, BellSouth will credit <<customer\_short\_name>>'s account for the difference.

[BellSouth Version] <<customer\_short\_name>> shall have thirty (30) business days from receipt of the firm price quote to accept or deny the firm price quote and submit any additional **Development** or nonrecurring rates quoted in the firm price quote. If the firm price quote is less than the preliminary analysis' estimated **Development Rate** and/or nonrecurring rate for the new or modified network element, interconnection option or service option not ordered by the FCC or Commission, BellSouth will credit <<customer\_short\_name>>'s account for the difference.

- 1.11 Unless <<customer\_short\_name>> agrees otherwise, all prices shall be consistent with the applicable pricing principles and provisions of the Act and rules, orders and regulations of the FCC and/or the Commission.
- 1.12 If <<customer\_short\_name>> believes that BellSouth's firm price quote is not consistent with the requirements of the Act, either Party may seek dispute resolution in accordance with the dispute resolution provisions set forth in the General Terms and Conditions of this Agreement. Any such arbitration applicable to network element, interconnection option and/or service option pricing shall be conducted in accordance with standards prescribed in Sections 251 and 252 of the Act. While the dispute is pending, <<customer\_short\_name>> shall have the option of requesting BellSouth to provide the network element, interconnection option or service option subject to a retroactive pricing true up upon an effective Commission order resolving the dispute. The Parties agree that subsequent true-ups may result from multiple rounds of appellate or reconsideration decisions, should the relevant Party pursue such appeals/reconsiderations/review and prevail. BellSouth will provide a cost study upon request after the firm quote.
- 1.13 If either Party believes that the other is not acting in good faith in requesting, negotiating, processing or implementing the BFR, either Party may seek to resolve the dispute pursuant to the dispute resolution provisions set forth in the General Terms and Conditions of this Agreement.
- 1.14 Upon agreement to the rates, terms and conditions of a BFR, the Parties shall negotiate in good faith an amendment to this Agreement.

## 2.0 **NEW BUSINESS REQUEST**

- 2.1 <<customer\_short\_name>> also shall be permitted to request the development of new or revised facilities or service options which may not be required by the Act. Procedures applicable to requesting the addition of such elements, services and options are specified in this Attachment 11. A New Business Request (NBR) is to be used by <<customer\_short\_name>> to make a request of BellSouth for a new or

modified feature or capability of an existing product or service, a new product or service that is not deployed within the BellSouth network or operations and business support systems, or a new or modified service option that was not previously included in this Agreement (Requested NBR Services) and is not required by the Act.

- 2.2 An NBR shall be submitted in writing by <<customer\_short\_name>> and shall specifically identify the requested service date, technical requirements, space requirements and/or such specifications that clearly define the request such that BellSouth has sufficient information to analyze and prepare a response. The request shall be sent to <<customer\_short\_name>>'s designated BellSouth sales contact or Local Contract Manager.
- 2.3 Within two (2) business days of receipt of an NBR, BellSouth shall acknowledge in writing its receipt and identify a single point of contact responsible for responding to the NBR And shall request any additional information needed to process the request to the extent known at that time. Notwithstanding the foregoing, BellSouth may reasonably request additional information from <<customer\_short\_name>> at any time during the processing of the NBR.
- 2.4 If the preliminary analysis of the requested NBR is not of such complexity that it will cause BellSouth to expend extraordinary resources to evaluate the NBR, within thirty (30) business days of its receipt of the NBR, BellSouth shall respond to <<customer\_short\_name>> by providing a preliminary analysis of such Requested NBR Services that are the subject of the NBR. The preliminary analysis shall either confirm that BellSouth will offer access to the Requested NBR Services or confirm that BellSouth will not offer the Requested NBR Services.
  - 2.4.1 If the preliminary analysis states that BellSouth will offer the Requested NBR Services, the preliminary analysis will include an estimate of the Development Rate including a general breakdown of costs and the date the request can be met. If BellSouth cannot provide the Requested NBR Service by the requested date, it shall provide an alternative proposed date together with a detailed explanation as to why BellSouth is not able to meet <<customer\_short\_name>>'s requested date. If the preliminary analysis states that BellSouth will not offer the Requested NBR Services, BellSouth will provide an explanation of why the request is not technically feasible, does not qualify as an NBR for the Requested NBR Services.
- 2.5 If BellSouth determines that the preliminary analysis of the requested NBR is of such complexity that it will cause BellSouth to expend extraordinary resources to evaluate the NBR, BellSouth shall notify <<customer\_short\_name>> within ten (10) business days of BellSouth's

receipt of the NBR that a complex request evaluation fee will be required prior to the evaluation of the NBR. Such fee shall be limited to BellSouth's extraordinary expenses directly related to the complex request. If <<customer\_short\_name>> accepts the complex request evaluation fee amount proposed by BellSouth, <customer\_short\_name>> shall submit such complex request evaluation fee within thirty (30) business days of BellSouth's notice that a complex request evaluation fee is required.

- 2.6 Within thirty (30) business days of BellSouth's receipt of the complex request evaluation fee, BellSouth shall respond to <<customer\_short\_name>> by providing a preliminary analysis of such Requested NBR Services that are the subject of the NBR.
- 2.7 <<customer\_short\_name>> may cancel an NBR at any time. If <<customer\_short\_name>> cancels the NBR within ten (10) business days after submitting the NBR, no charges will be incurred. If <<customer\_short\_name>> cancels the NBR within thirty (30) business days after receipt of BellSouth's preliminary analysis, BellSouth shall be entitled to keep any complex request evaluation fee submitted in accordance with Section 2.6, minus those costs included in the fee that have not been incurred as of the date of cancellation.
- 2.8 <<customer\_short\_name>> will have thirty (30) business days from receipt of preliminary analysis to accept the preliminary analysis or cancel the NBR. If <<customer\_short\_name>> fails to respond within this thirty (30) business day period, the NBR will be deemed cancelled.
  - 2.8.1 Acceptance of the preliminary analysis must be in writing and accompanied by the estimated Development Rate for the Requested NBR Services quoted in the preliminary analysis.
- 2.9 BellSouth shall propose a firm price quote including the firm Development Rate, the firm nonrecurring rate, and the firm recurring rate and a detailed implementation plan within ten (10) business days of receipt of <<customer\_short\_name>>'s accurate NBR application for a Requested NBR Service that is operational at the time of the request and within sixty (60) business days of receipt of <<customer\_short\_name>>'s accurate NBR application for the Requested NBR Services not operational at the time of the request. The firm nonrecurring rate will not include any of the Development Rate or the complex request evaluation fee, if required, in the calculation of this rate. Such firm price quote shall not exceed the estimate provided with the preliminary analysis by more than 25%.

- 2.10 <<customer\_short\_name>> shall have thirty (30) business days from receipt of firm price quote to accept or deny the firm price quote and submit any additional nonrecurring, non-refundable fees quoted in the firm price quote. If the firm price quote is less than the preliminary analysis' estimate of the Development Rate, BellSouth will credit <<customer\_short\_name>>'s account for the difference.
- 2.11 Unless <<customer\_short\_name>> agrees otherwise, all prices shall be consistent with the applicable pricing principles and provisions of the Act and rules, orders and regulations of the FCC and/or the Commission.
- 2.12 If either Party believes that the other is not acting in good faith in requesting, negotiating, processing or implementing the NBR, either Party may seek to resolve the dispute pursuant to the dispute resolution provisions set forth in the General Terms and Conditions of this Agreement.
- 2.13 Upon agreement to the rates, terms and conditions of a NBR, an amendment to this Agreement, or a separate agreement, may be required and the Parties shall negotiate such agreement or amendment in good faith.

**ATTACHMENT 12**  
**BAPCO AGREEMENT**



## AGREEMENT

In consideration of the mutual promises contained herein, BellSouth Advertising & Publishing Corporation, a Georgia corporation ("BAPCO") and \_\_\_\_\_, a \_\_\_\_\_ corporation ("CARRIER") agree as follows:

1. RECITALS. BAPCO is the publisher of alphabetical (or White Pages) and classified (or Yellow Pages) directories for certain communities in the southeastern region of the U.S. (the "Directories"). CARRIER provides, or intends to provide, local exchange telephone service in communities in which BAPCO publishes Directories. BAPCO and CARRIER hereby establish the terms by which BAPCO will include listings of CARRIER subscribers in such Directories and by which BAPCO will provide such Directories to CARRIER subscribers.

2. CARRIER OBLIGATIONS. CARRIER agrees as follows:

(a) CARRIER shall provide to BAPCO, or its designee, at CARRIER's expense and at no charge, listing information (including changes and disconnects) concerning its subscribers (designating any who do not desire published listings), consisting of customer name, address, telephone number and all other information reasonably requested by BAPCO as set forth on Exhibit A in a mutually acceptable format for use by BAPCO or its affiliates in publishing Directories of whatever type and format and for other derivative purposes. Such subscriber listing information shall be provided in the format and on the schedule set forth in said Exhibit, or as otherwise mutually agreed between the parties from time to time.

(b) CARRIER shall also provide directory delivery information to BAPCO as set forth in Exhibit A for all subscribers.

(c) CARRIER shall advise BAPCO promptly of any directory-related inquiries, requests or complaints which it may receive from CARRIER subscribers and shall provide reasonable cooperation to BAPCO in response to or resolution of the same.

(d) CARRIER shall respond promptly regarding corrections or queries raised by BAPCO to process listing changes requested by subscribers.

3. BAPCO OBLIGATIONS. BAPCO agrees as follows:

(a) BAPCO shall include at no charge to CARRIER one standard listing for each CARRIER subscriber per hunting group in BAPCO's appropriate local alphabetical Directory as published periodically by BAPCO unless nonlisted or nonpublished status is designated by subscribers. Such listings shall be interfiled with the listings of other local exchange telephone company subscribers and otherwise published in the manner of such other

listings according to BAPCO's generally applicable publishing policies and standards. BAPCO shall provide a process whereby CARRIER is afforded a reasonable opportunity to review and correct its subscribers' alphabetical listings in advance of publication.

(b) BAPCO shall publish additional listings, foreign listings and other alphabetical Directory listings offered by BellSouth, for CARRIER subscribers upon their request consistent with BAPCO's generally applicable policies in BAPCO's alphabetical Directories. BAPCO shall publish all listings for all CARRIER subscribers in substantially the same manner and upon the same rates, terms, conditions and applicable policies.

(c) BAPCO will distribute its regularly published alphabetical and classified Directories to local CARRIER subscribers at no charge to CARRIER or CARRIER's subscribers in accordance with BAPCO's prevailing practices, including delivery following Directory publication and upon establishment of new CARRIER service, if a current Directory for that geographic area has not previously been provided. Such deliveries may include separate advertising materials accompanying the Directories.

(d) BAPCO will include CARRIER information in substantially the same manner as that included for all other carriers information relating to establishment of service, repair and billing in the generic customer guide pages of its alphabetical Directories for communities where CARRIER is certificated to provide local exchange telephone service at the time of publication in accordance with BAPCO's prevailing standards for the same. CARRIER will provide information requested by BAPCO for such purpose on a timely basis.

(e) BAPCO shall make available at no charge to CARRIER or its subscribers one listing for CARRIER business customers per hunting group in one appropriate heading in BAPCO's appropriate local classified directory as published periodically by BAPCO. Such listings shall be published according to BAPCO's generally applicable publishing policies and standards.

(f) BAPCO may solicit, accept and publish directory advertising from business subscribers of CARRIER in communities for which BAPCO publishes classified Directories in the same manner and upon substantially the same terms as it solicits, accepts and publishes advertising from advertisers who are not CARRIER subscribers. Such advertising shall be furnished pursuant to an arrangement/agreement between BAPCO and the subscriber, and not pursuant to this agreement.

(g) BAPCO will not provide or use information obtained from CARRIER concerning its subscribers to other local exchange telephone service providers without CARRIER approval, except as may be required in relation to publishing of Directories or as may be permitted by CARRIER for directory assistance or other purposes.

(h) BAPCO and CARRIER acknowledge that mutual cooperation will be required to successfully serve the needs of their common customers and therefore agree to

use reasonable efforts to provide such cooperation to achieve the highest quality of service for both parties' customers.

4. PUBLISHING POLICIES. BAPCO shall maintain full authority over its publishing schedules, policies, standards, and practices and over the scope and publishing schedules of its Directories. BAPCO shall periodically provide CARRIER with changes by BAPCO in the same schedules, policies, etc. which in BAPCO's judgment affect CARRIER's conduct in BAPCO's publishing of listings for CARRIER's subscribers. Such policy updates shall include, without limitation, the subjects described in Exhibit B.

5. LIABILITY AND INDEMNITY.

(a) BAPCO's liability to CARRIER for any errors or omissions in directories or for any default otherwise arising hereunder shall be limited to One Dollar (\$1) for errors or omissions in any subscriber listing in any directory published by BAPCO.

(b) Each party agrees to defend, indemnify and hold harmless the other from all damages, claims, suits, losses or expenses, including without limitation costs and attorney's fees, to the extent of such party's relative fault, arising out of or resulting from any error, omission or act of such party hereunder. Each party shall notify in writing the other promptly of any claimed error or omission affecting this paragraph and of any claim or suit arising hereunder or relating to this Agreement and shall provide reasonable and timely cooperation in its resolution of the same. Without waiver of any rights hereunder, the indemnified party may at its expense undertake its own defense in any such claim or suit.

6. TERM. This Agreement shall be effective on the date of the last signature hereto for a term of three (3) years and shall relate to Directories published by BAPCO during such period. Thereafter, it shall continue in effect unless terminated by either party upon sixty days prior written notice.

7. ASSIGNMENT. This Agreement shall be binding upon any successors or assigns of the parties during its Term.

8. RELATIONSHIP OF THE PARTIES. This Agreement does not create any joint venture, partnership or employment relationship between the parties or their employees, and the relationship between the parties shall be that of an independent contractor. There shall be no intended third party beneficiaries to this Agreement.

9. NONDISCLOSURE.

a. During the term of this Agreement it may be necessary for the parties to provide each other with certain information ("Information") considered to be private or proprietary. The recipient shall protect such Information from distribution, disclosure or dissemination to anyone except its employees or contractors with a need to know such Information in conjunction herewith, except as otherwise authorized in writing. All such Information shall be in writing or other tangible form and clearly marked with a

confidential or proprietary legend. Information conveyed orally shall be designated as proprietary or confidential at the time of such oral conveyance and shall be reduced to writing within forty-five (45) days.

b. The parties will not have an obligation to protect any portion of Information which: (1) is made publicly available lawfully by a nonparty to this Agreement; (2) is lawfully obtained from any source other than the providing party; (3) is previously known without an obligation to keep it confidential; (4) is released by the providing party in writing; or (5) commencing two (2) years after the termination date of this Agreement if such Information is not a trade secret under applicable law.

c. Each party will make copies of the Information only as necessary for its use under the terms hereof, and each such copy will be marked with the same proprietary notices as appear on the originals. Each party agrees to use the Information solely in support of this Agreement and for no other purpose.

10. FORCE MAJEURE. Neither party shall be responsible to the other for any delay or failure to perform hereunder to the extent caused by fire, flood, explosion, war, strike, riot, embargo, governmental requirements, civic or military authority, act of God, or other similar cause beyond its reasonable control. Each party shall use best efforts to notify the other promptly of any such delay or failure and shall provide reasonable cooperation to ameliorate the effects thereof.

11. PUBLICITY. Neither party shall disclose the terms of this Agreement nor use the trade names or trademarks of the other without the prior express written consent of the other.

12. REPRESENTATIVES AND NOTICES.

a. Each party shall name one or more representative for contacts between the parties which shall be authorized to act on its behalf. Such representatives may be changed from time to time upon written notice to the other party.

b. Notices required by law or under this Agreement shall be given in writing by hand delivery, certified or registered mail, or by facsimile followed by certified or registered mail, addressed to the named representatives of the parties with copies to:

If to BAPCO:

Directory-Operational Support  
BellSouth Advertising & Publishing Corporation  
Room 8A851  
2247 Northlake Parkway  
Tucker, GA 30084

With Copy to: Vice President and General Counsel  
BellSouth Advertising & Publishing Corporation  
Room 10A1057  
2247 Northlake Parkway  
Tucker, GA 30084

If to CARRIER: \_\_\_\_\_  
\_\_\_\_\_  
\_\_\_\_\_  
\_\_\_\_\_

13. MISCELLANEOUS. This Agreement represents the entire Agreement between the parties with respect to the subject matter hereof and supersedes any previous oral or written communications, representations, understandings, or agreements with respect thereto. It may be executed in counterparts, each of which shall be deemed an original. All prior and contemporaneous written or oral agreements, representations, warranties, statements, negotiations, and /or understandings by and between the parties, whether express or implied, are superseded, and there are no representations or warranties, either oral or written, expressed or implied, not herein contained. This Agreement shall be governed by the laws of the state of Georgia.

IN WITNESS WHEREOF, the parties have executed this Agreement by their duly authorized representatives in one or more counterparts, each of which shall constitute an original, on the dates set forth below.

BELLSOUTH ADVERTISING &  
PUBLISHING CORPORATION

CARRIER:

By: \_\_\_\_\_  
(Signature)

By: \_\_\_\_\_  
(Signature)

Name: Scott Asher

Name: \_\_\_\_\_

Title: Director – Operational Support

Title: \_\_\_\_\_

Date: \_\_\_\_\_

Date: \_\_\_\_\_

## EXHIBIT A

### ACCOUNT INFORMATION (Mandatory data)

1. Main Account Telephone Number: Main line of telephone service that all other numbers are associated with. (Area Code/ NXX/Line Numbers)
2. Old Telephone Number: If the number is changing.
3. Class of Service: Business or Residence
4. Order Type: N – New connect order; D – Disconnect service order; R – Record change order; C – Change of listings (Out and In action codes.)
6. Due Date: Date the service is requested.
8. Company Code: Operating Company Number.
9. Service Address: Physical location of the telephone.

### PRIMARY LISTING INFORMATION

10. Listed Name: The way the listing is to appear in the directory. Caption arrangements should be formatted per guidelines. Non-Pub or Non-List situations should be indicated. (Mandatory)
11. Listed Address: Current address may include street number – street name, city and state. (Note P.O. Box or Route not acceptable). Listed address may be omitted.
12. Published Telephone Number: Telephone number to appear in the directory. (Mandatory)
13. Community Name: The community name where the listing appears should be supplied, if the community is other than the community in the directory name.
14. Yellow Pages Heading: The Yellow Page heading where customer wants his listing to appear. (Valid and mandatory for Business Primary Listings only.)
15. Directory Name: Name of the foreign directory where the customer desires a foreign listing to appear (including town section if applicable). (Mandatory for foreign record types only.)

### DIRECTORY DELIVERY INFORMATION

16. Name: Personal or business name. (When this information is not supplied, the data will default from the Name field of the EU section.)
17. Delivery Address: Street number, street name, city, state, zip code of where directories are to be delivered. (When this information is not supplied, the data will default from the Service Address.)
18. Number of books now: for immediate delivery/replacement.
19. Number of books annually: 0 – 3 residence, 0 – 5 business, then negotiated. (Mandatory)

### REMARKS SECTION (As required)

20. Remarks: Free flow field used by Carrier for any additional information.

**BAPCO Deliverables \*****Abbreviations Table**

BAPCO will provide copy of the standard abbreviations utilized for given names, titles of address, titles of lineage, military titles, degrees and professional affiliations standards. This information can be used to assist in effectively processing various listed name request.

**Central Office Table**

BAPCO will provide what is called the ABC table. This report identifies by NPA and in sequence by central office the directory in which a customer is entitled to appear.

**Coverage Maps**

BAPCO will provide a coverage map for its major directories identifying broadly the geographic area served by the major directory. These maps will be provided only for the major directories in the area served by the carrier.

**Customer Guide Pages Appearance Procedures**

BAPCO will provide free listing appearance under the areas of Establishing Service, Billing and Repair in the Customer Guide Section of the White Pages for directories where a carrier operates. These procedures identify how to get your listing to appear and procedures for purchasing LEC specific pages.

**Foreign Directory Name Table**

BAPCO will provide all foreign names to be used in the processing of foreign listing requests. This field is a required element in the establishment of foreign listings.

**Listing Guidelines**

BAPCO will provide an example of the most common listing elements and their entitlement to appearance in the White and Yellow Pages.

**Listing Standards and Regulations**

BAPCO will provide a condensed version of listing specifications reflecting the rules and regulations regarding listing appearance in both the White and Yellow Pages.

**Publication Schedules**

BAPCO will provide to all carriers the publication schedules for all directories within the area served by the carrier. This schedule will include the name of the directory, the directory bolt code, the business office close date and the issue date. The business office close date represents the last day to receive activity for appearance in the subsequent directory. This date also represents the close date for advertising activity into the Yellow Pages.

The issue date represents the mid-point of delivery of the new directory and the date at which new directory billing will begin for the directory being delivered. The length of the delivery period will vary depending upon the size of directory.

**Yellow Pages Headings**

BAPCO will provide the Yellow Pages Heading file which will include all Yellow Pages headings allowed by BAPCO, the Yellow Pages heading code and the associated SIC code. The material would be utilized to assist the business customer in identifying where they would like representation in BAPCO's classified Yellow Pages directories.

*\*This information is accessible via the web at [www.bellsouth.com/clec](http://www.bellsouth.com/clec), a password protected web-site and may be downloaded for use as needed..*